



GOVERNMENT OF TAMIL NADU

HIGHER SECONDARY SECOND YEAR

VOCATIONAL EDUCATION

Basic Civil Engineering

THEORY & PRACTICAL

A Publication Under Free Textbook Programme of Government of Tamil Nadu

Department of School Education

Untouchability is Inhuman and a Crime

Government of Tamil Nadu

First Edition - 2019

Revised Edition - 2020, 2022

(Published under New Syllabus)

NOT FOR SALE

Content Creation



State Council of Educational
Research and Training

© SCERT 2019

Printing & Publishing



Tamil Nadu Textbook and
Educational Services Corporation
www.textbooksonline.tn.nic.in



Preface

This book on “Basic Civil Engineering” has been written entirely based on new syllabus framed by TNSCERT. The subject matter is explained in a simple and lucid language, lightened by sufficient colourful diagrams, illustrations with learning objectives.

In each chapter, Quotes, Activities, “Do you Know?” and web search links were given which enhance the students knowledge. QR Codes for the tough area of the subject were marked. This will help the students to understand the subject further in detail. A set of Model Questions were also included at the end of each unit.

Case studies which were included at the end of this book would be useful to motivate the students and also give an idea about the diversity of their course.

I extend my sincere thanks to the Director, Joint Director and Staff members whose patronage on this book to come out and the committee of learned Teachers who shouldered the responsibility to bring the book in good shape.

Despite all our efforts, some errors and minor mistakes might have crept in. Your positive suggestion, regarding the improvement of this book will be thankfully acknowledged.

Learning Objectives

Learning objectives are brief statements that describe what students will be expected to learn by the end of school year, course, unit, lesson or class period

Chapter Outline

Illustrate the complete overview of chapter



Amazing facts, Rhetorical questions to lead students to Engineering inquiry

Activity

Directions are provided to students to conduct activities in order to explore, enrich the concept

Infographics

Visual representation of the lesson to enrich learning

Evaluation

Assess students to pause, think and check their understanding

HOW TO USE THE BOOK?



To motivate the students to further explore the content digitally and take them in to virtual world

Career corner

List of professions related to the subject

References

List of related books for further details of the topic

Web links

List of digital resources

Glossary

Explanation of Engineering terms

Competitive Exam questions

Model questions to face various competitive exams



Career Guidance

Vertical Mobility - Higher Education

After completion of Basic Civil Engineering Vocational Group, students are eligible

- To join Bachelor degree in any discipline in Engineering Colleges.
- To join Bachelor degree in Architecture.
- To join directly in second year Diploma Engineering in polytechnic colleges in any discipline.
- To join AMIE through Distance education which is equal to Bachelor in Engineering.
- To join Diploma in Teacher Education.
- To join B.Sc Mathematics.
- To join B. Com., B.A., B.B.A, B.C.S, B.C.A, etc.,
- To join B.L, L.L.B (Law Courses)
- To join Diploma and B.Sc in Catering Technology.

Horizontal Mobility (Employment/Self Employment)

Employment

Join as Apprentice Trainee/Site Supervisors in reputed companies like

- L & T Construction pvt ltd.
- Various private construction companies.
- As CAD Draughtsman in Architectural offices.
- As field surveyor.
- As quantity surveyor.

Self-Employment

- After getting sufficient knowledge in this field, can do Building Construction Works individually.

Competitive Exam

- TNPSC – www.tnpsc.gov.in
- Railway Recruitment Board (RRB) www.Indainrailways.gov.in
- Indian Navy – www.indiannavy.nic.in
- Indian Army – www.indiannavy.nic
- Indian Air Force – www.indianairforce.nic.in
- Indian Coast Guard – www.joinindiancoastguard.gov.in
- Tamilnadu Uniform Service Recruitment Board – www.tnsrb.gov.in
- Central Reserve Police Force (CRPF) [www. http://crpf.nic.in](http://www.http://crpf.nic.in)
- Indian Postal Department – www.indianpost.gov.in
- LIC of India www.lic.in



Contents

Basic Civil Engineering

| Serial No. | Unit No. | Chapter Title | Page No. | Month |
|------------|----------|--|----------|------------------|
| 1. | 1. | Planning of House | 1-16 | June |
| 2. | 2. | Special Building Materials | 17-34 | July |
| 3. | 3. | Surveying | 35-59 | August |
| 4. | 4. | Water Supply Engineering | 60-84 | August-September |
| 5. | 5. | Sanitary Engineering | 85-107 | October |
| 6. | 6. | Highway Engineering | 108-133 | October-November |
| 7. | 7. | Hydraulics | 134-153 | November |
| 8. | 8. | Disaster Management | 154-163 | December |
| | | <i>Basic Civil Engineering Practical</i> | 164-218 | |
| | | <i>Case Studies</i> | 219-221 | |
| | | <i>Marks Allocation</i> | 222 | |
| | | <i>Model Question Paper I</i> | 223-225 | |
| | | <i>Model Question Paper II</i> | 226-228 | |
| | | <i>References</i> | 229 | |
| | | <i>Common Glossary</i> | 230-237 | |



E-book



Assessment



Basic Civil Engineering

THEORY



UNIT 1

PLANNING OF HOUSE



“ You need a plan to build a house. To build a life, it is even more important to have a plan or goal. ”

Zig Ziglar



Table of Contents

| | |
|--|---|
| 1.1 Introduction | 1.5 Principles of organizing a house |
| 1.2 Importance of house | 1.6 House plan |
| 1.3 Orientation | 1.6.1 Rooms in a house |
| 1.4 Site selection | 1.7 Housing |
| 1.4.1 Factors to be considered during site selection | 1.7.1 Housing demand |
| | 1.7.2 Types of Residential Houses |

Learning Objectives

At the end of this lesson you shall be able to

- Understand the importance of house.
- Know about the orientation of house.
- List the factors to be considered during site selection.
- Understand the principles of organizing a house.
- List the rooms in a house.
- Prepare a house plan.
- Explain the housing demand.
- List the types of residential houses.

1.1 Introduction

Food, shelter and clothes are the basic needs of mankind for a comfortable living. Among these shelter is highly essential. During ancient times, man used to live in dens. As the culture of mankind improved, science and technology also developed. Man utilized this technological development for building his house with all sophistications and facilities.



Ancient Den



Modern House

1.2 Importance of house

- i. A house is a shelter for man constructed with materials like stones, bricks, lime, cement, timber, steel, etc. It consists of foundation, walls, floor, roof, doors and windows. To get rid of the outside busy life and worries, man feels his house as a relaxed and rest place.
- ii. A house protects the family from severe heat, cold, rain, storm, harmful animals and also from anti-social elements.
- iii. A house binds the family members with love and affection. It brings them closer and helps them to understand each other and live together.
- iv. For the general activities of a family like cooking, serving, washing, cleaning, storing materials, welcoming the guests, disposing the waste, etc., and for individual activities like reading, relaxing, sleeping, bathing, etc., a house forms the centre.
- v. House facilitates a man to express his feelings and to act independently.
- vi. A well planned house provides privacy, adequate rest and a healthy atmosphere to the family. It provides

them feeling of governance, vision, affection and protection.

- vii. Only in a house, an individual understands the heritage of his family, culture and habits.
- viii. A house and its surrounding depicts the fame of the family.
- ix. One of the factors which decides the status of a family is the house in which they live.
- x. The development of a nation can also be measured by the colonies of houses in it.

1.3 Orientation

For a healthy life, the natural resources like sunlight, clean air and sufficient rain are mandatory requirements. But at the same time, care should be taken to see that these do not affect the people residing in the house. For this, the orientation of the house constructed in a particular plot is important. The entrance of the house and the orientation of the house should be in such a way that it allows adequate sunlight in the morning and also prevents the inmates from excessive heat during the day.

The doors and windows should be placed and arranged so as to allow adequate air. It is always better to have a verandah in front of the house. Each room should be oriented and placed depending upon the nature of activity it is intended for. Care should be taken for sufficient air and ventilation to all rooms.

1.4 Site selection

Since a house forms one of the basic requirement of man, to satisfy this, he has to initially select a suitable

site for construction. Each and every individual spend a major portion of their savings for purchasing a site and constructing a house. After which they don't move away or change their house. Therefore a good sense regarding site selection and house construction becomes necessary.

1.4.1 Factors to be considered during site selection.

1. Physical features

- i. The plot should be regular with well-defined boundaries on all sides.
- ii. It is better to have an elevated plot when compared to its surrounding areas for better visualisation.
- iii. In elevated areas, water does not stagnate which becomes ideal for living.
- iv. If the site is in low-lying area, it leads to water stagnation, breeding of insects and unhealthy living condition.
- v. It is always better to choose a site oriented towards North or South for better air flow.

2. Soil conditions

Before constructing the house, it is always advisable to check the properties of the soil. This will avoid unnecessary problems during construction and prevent loss of money.

- i. Clayey soil is not good for construction. Because it does not absorb water and retains it.
- ii. Sandy soil absorbs water quickly and hence a strong foundation cannot be laid on it. More over sandy soil is not suited for gardening.
- iii. Strong foundation could be laid on a rocky strata but it is not an

ideal site for house construction as it radiate heat during night.

- iv. Hence a site consisting of soft soil at top and hard soil at the bottom at a depth of 0.9 to 1.2 m is considered ideal for house construction.

3. Sanitary facilities

- i. The area surrounding the proposed plot of house construction should be free from stagnated water, small ponds and deteriorated wells.
- ii. Care should be taken to see that there are no open drainage or public toilets near the plot.
- iii. For the benefit of the family members, the plot should not be selected near cow sheds, poultry farms, industries and burial/cremation grounds.
- iv. Low lying areas which were later filled up with garbage, other city wastes and disposed materials should never be selected for house construction. Because, the bearing capacity of such areas will not be firm or strong. Moreover at the time of heavy rain, these dumped up areas become saturated and promote the breeding of mosquitoes and flies, polluting the surrounding atmosphere with foul smell and causing threat to health.
- v. It is advisable to select a plot with fresh air, adequate light, good water supply and modern sanitary facilities.

4. Practical conveniences

- i. A plot is valued based on the basic facilities that are available around it.
- ii. A plot should be located in such a way that schools, bank, hospital,

market, etc., are at walkable distances.

- iii. If bus stand, railway station, etc., are near by the proposed plot, it will be very convenient for the family members to reach their offices, colleges or schools.

5. Neighbourhood

- i. For guaranteed permanent happiness of the family it is always better to purchase a plot in a developed locality or in a developing locality.
- ii. The plot should be chosen in such a locality where the neighbours residing there are of the same status when compared to us both socially and economically.
- iii. If the plot is adjacent to seashore, one could enjoy the fresh sea breeze. But at the same time, the chlorides present in sea breeze can corrode the steel cup boards, furniture, window and door grills etc., quickly.
- iv. If the plot is located in heavy traffic zone it leads to sound pollution, air pollution, etc., resulting in ill-health.

6. Legal characteristics

- i. Before choosing a plot in a particular locality, it is good to know all the legal aspects completely regarding the plot and its locality by consulting a lawyer.
- ii. The plot should be free from any encumbrance.
- iii. The boundaries of the plot have to be predicted properly and its area has to be checked.
- iv. It is good to purchase a plot which confirms the bye laws laid by municipality, town panchayat or Metropolitan Development Authority (MDA).

1.5 Principles of organizing a house

Though a plot may be of any geometric shape, there are certain principles which govern the shape of the building to be constructed in it as given below

- i. External appearance
- ii. Front elevation
- iii. Privacy
- iv. Grouping of rooms
- v. Roominess
- vi. Circulation
- vii. Flexibility
- viii. Sanitation
- ix. Placement of furniture
- x. Practical consideration

i. External appearance

External appearance mainly includes the location of doors and windows. The doors and windows should be located in such a way that natural resources like fresh air, sun light, natural scenery, etc., are enjoyed to the maximum extent.

ii. Front elevation

A house should have a pleasing and attractive appearance when it is viewed from outside. It should be modern and constructed with various features like beautiful balcony, carved pillars, simple and modern roofs.

iii. Privacy

It is important to take into consideration the privacy of each and every room in a house.

Privacy is of two types:-

- Privacy of individual room from other rooms and verandah.

While positioning the rooms, care should be taken to see that doors,

windows of the rooms do not face each other. If necessary, curtains could be utilized to create privacy.

■ Privacy of entire house from street.

Trees or creepers can be grown in front of the house so that privacy can be obtained for the house from the street.

iv. Grouping of rooms

Based on the routine works that are performed in a house, the rooms shall be arranged adjacent to each other.

To simplify the utility of the family members, dining hall should be placed adjacent to the kitchen, living room adjacent to the verandah, bathroom and water closet should be constructed adjacent to the bedroom.

v. Roominess

A house should be planned and constructed in such a way that the interior of the house is magnified to the maximum extent possible. The available area should be well planned so that, not even a small bit of area is left unutilized. Shelves could be constructed in the walls and lofts could be constructed beneath the roof to store articles. By this way the carpet area of the house could be maximized. The space available beneath the staircase could be covered and also utilized for storing articles. The size and shape of the room, the number and arrangements of furniture, interior wall colour also helps to maximize the carpet area of the room.

vi. Circulation

The path leading from one room to another should be simple, straight and short. It is better to provide separate entrance for every room or the entrance for individual rooms could be from a common passage. None of the rooms should have

their entrance positioned in another room which will lead to inconvenience to the inmates.

Proper positioning of rooms and proper arrangement of furniture like sofa, tables and chairs towards the corner of the walls will facilitate uninterrupted walking space inside a house.

vii. Flexibility

The utility of a room should not only be for a particular purpose. Instead, it should be flexible enough to adopt various other utilities according to the need. It will solve the space problem. For example if the living room is constructed bigger in size, a portion of it could be utilized for dining and also could be utilized for sleeping during night times. Utilizing the kitchen for dining purpose, utilizing the verandah adjacent to kitchen as play area for small kids will solve space problems to a certain extent.

Curtains, folding screens, almirahs, plywood boards, etc., could be used to partition the common area for various activities.

viii. Sanitation

A house should always be constructed with good ventilation, proper lighting and sanitation facilities. Proper planning should be done to drain waste water from kitchen, bathroom and water closet in a hygienic way.

ix. Placement of furniture

A room in a house should be planned and constructed in such a way keeping in mind the furniture that are to be placed in it. The position of sofa sets, tables and chairs and their sizes should be so fixed initially keeping in view

the position and size of doors, window openings and shelves in the wall.

x. Practical considerations

Since a house is an asset which cannot be shifted from one place to another, the following points should be considered while planning and constructing a house.

- i. It should possess a strong structural integrity.
- ii. Should have all facilities within.
- iii. Should have simple structural configurations.



Building lifting technique

- This technique was introduced for the first time in Philadelphia, Pennsylvania in 1799 for the purpose of moving a building.
- When the road level is increased above the level of building, then it is necessary to lift/ elevate the building.
- If the house is below the street level and sewage water regularly flows in, relocation is not the best solution.
- There is a solution to this problem and it would be house lifting
- There are lot of mistakes done during the construction of house or building. Many times the owner think about to correct those wrong done , but it takes lot of money and time. There was no solution in the past. But now here is the solution, i.e. **Building Lifting Technique**.
- The building is separated from its foundation, lifted with hydraulic jacks and placed on a new or extended foundation.



- iv. It should be attractive.
- v. It should be flexible to adapt to the needs of the future expansion without being demolished and reconstructed.
- vi. Above all, unnecessary construction costs should be avoided and entire construction should be carried out thrifty.

1.6 House Plan

Before constructing a house, it should be planned and presented in a drawing form on a paper.

Following details could be obtained from the plan of a house.

- i. General arrangement of all the rooms in the house.
- ii. The length and breadth of individual rooms.
- iii. Wall thickness.
- iv. The numbers and positions of doors, windows and cupboards / shelves.

For an enjoyable family life adequate space is very important in all the rooms.

Hence, arrangement of rooms in a proper way becomes the important feature in house planning.



1.6.1 Rooms in a house

1. Verandah
2. Living room
3. Bed room
4. Kitchen
5. Dining room
6. Pooja room
7. Bath room

1. Verandah

A verandah is constructed in the entrance of a house. It is beneficial in the following ways.

- i. Strange people could be seated in verandah.
- ii. Articles like umbrella, walking stick and chappals could be left in the verandah. Also bicycles and two wheelers could be parked in it.



- iii. It is the place where family members get together and sit during evenings or nights to obtain fresh breeze.
- iv. Pet animals could be tied in the verandah.
- v. It is the place where plants could be grown in pots.
- vi. Verandah at the back of the house could be utilized for drying clothes and utensils after washing.
- vii. Care should be taken to see that the span of the verandah does not exceed 3 m.

2. Living room

- i. The room next to the front verandah is the living room.
- ii. This room is also called as drawing room.
- iii. A living room should fulfill the various desires of the family members. For example: It should be sufficient enough for all the family members to get together and enjoy, for hospitality of guests, for little children to play, for reading news paper, for listening music, etc.
- iv. Sometimes the living room is utilized for small parties. (e.g.) Birthday party.
- v. Due to shortage of space in certain houses, the living room is utilized as study room and bedroom during nights. Sometimes it gets converted as a guest room.
- vi. The living room should expose the general attitude of the family. It should provide a warm reception to the guests.
- vii. It should possess sufficient lighting, good ventilation and healthy atmosphere.
- viii. A living room should not be less than 4.5 m in length and 3.6 m in breadth. The shelves constructed in the walls should not be less than 0.9 m in width.
- ix. For privacy, the door of the living room should be positioned in a corner and not at the centre.
- x. Based on the size of living room, furniture should be placed to derive maximum benefits and comforts. Following are some of the furniture and articles that could be placed in a living room. Sofa for comfortable seating and discussion, easy chair for relaxation, teapoy for necessary



hospitality to guests, table and chair for studying, television for entertainment, built - in cupboard for placing articles.

- xi. A living room could further be decorated by suitable pictures, flower arrangements, carpets, etc. Artistic items and sculptures could be neatly arranged in a showcase or shelf that is available in a living room.

3. Bed room

- i. People spend one- third of their lifetime in sleeping.
- ii. A bedroom is not only utilized for sleeping, but it is also used for storing dress materials and for dressing.
- iii. Generally a room of size 4.5 m × 3.6 m is ideally suited for bedroom.
- iv. Care should be taken to see that the width of the bedroom should not be less than 3 m.
- v. A rectangular shape offers better comfort than a square shaped bed room.
- vi. Air circulation is most important for a bedroom. This room should be oriented towards the wind direction.
- vii. For privacy the door of the bedroom should be positioned in a corner. So that, the cot inside the bedroom is not visible from outside while opening the door.



- viii. It is necessary to provide a small bathroom cum water closet adjacent to the bedroom.
- ix. Bed spreads, pillow covers, dress materials, etc., can be stored in built-in cupboards or shelves.
- x. A small table and chair could be arranged adjacent to the cot for various purpose like reading, placing a table lamp, flower vase, etc.

4. Kitchen

- i. Kitchen is supposed to be the major work area for the women in the house. In this place the food for the entire family is being cooked.
- ii. In this room, provisionals, utensils, etc., are stored and electrical appliances for cooking like grinder, mixie, etc., are used.
- iii. Sometimes kitchen is also used for dining purpose.
- iv. Women spends most of her times in kitchen, hence care should be taken to see that the kitchen is spacious with sufficient air circulation and sunlight.
- v. The kitchen should be oriented towards south-east direction for sufficient sunlight to enter during the day. This purifies the air and provides warmth in the room. In the evenings the kitchen becomes cooler.
- vi. The size of the kitchen should be appropriately fixed for efficient functioning. It should neither be too big nor too small.
- vii. A kitchen should be constructed atleast to a size of 2.4 m × 3 m (or) 3 m × 3.6 m.
- viii. Major three work centers to be arranged in a kitchen are a) preparation centre, b) cooking centre and c) washing centre.
- ix. Unnecessary walking within the kitchen could be avoided if work centers are properly planned and positioned.
- x. The items required for the corresponding working centers should be made available in the respective centers. For this cupboards/shelves should be constructed near it.
- xi. A platform at a convenient height, should be placed so as to facilitate for standing and cooking. It helps to cook with ease and without getting tired.
- xii. A kitchen platform for better performance could be in the form of L or U.

5. Dining Room

- i. This room should be arranged adjacent to the kitchen. Only then it will be easy to serve the cooked food.
- ii. If properly planned, the closed verandah adjacent to kitchen could also be utilized for dining purposes.
- iii. Nowadays, people use tables and chairs for dining. Hence a rectangular shaped dining room with a rectangular dining table in it with dining chairs around will be ideal and convenient.
- iv. Chairs should be placed so as to provide maximum comfort while dining.
- v. The dining place should have adequate sunlight and air circulation with pleasing look.
- vi. The dining room should always be kept clean and tidy so that flies, cockroaches, etc., are avoided.



6. Pooja room

In every house there should be a small space for worshipping god. Hence, a pooja room for worshipping god could be planned in a calm portion of the house.

7. Bath room

- i. The main objective of this room is to provide adequate facilities for taking bath and washing clothes. Therefore, the size and shape of this room should be sufficient enough to offer the above facilities.
- ii. The size of the bath room should meet the standards.
- iii. A place has to be provided to keep soap, towel, tooth brush, tooth paste, etc.
- iv. Proper ventilation should be provided.
- v. The floor of the bathroom should be non-slippery, it should not catch stains and should be easily washable.
- vi. Porcelain tiles could be affixed on the wall from the floor to a height of 2 m, so that its glossy exterior will not catch stains easily and the bathroom will always look clean.

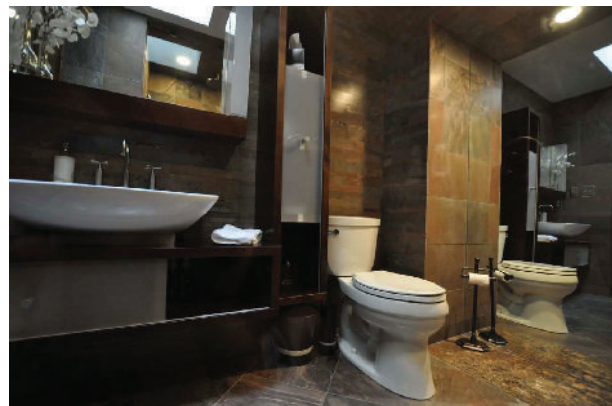

- vii. In modern residential buildings, particularly in big houses, bathroom and water closet are combined in a single room and attached to the master bedroom. Still, it is essential to have a common bathroom and toilet.



Expensive home in the world

Antilia, a 27 – storey skyscraper on the pricey Altamount Road in Mumbai, is the most expensive home in the world, valued of ₹ 7200 crore. Mukesh Ambani, an Indian business tycoon and multibillionaire, moved into the 400,000 – square foot mansion in 2012 with his wife and three children Antilia is a private home in South Mumbai, India.

600 staffs are used to maintain the residence 24 hours a day.

| | |
|-------------------|------------------------|
| Floors | : 27 Nos |
| Area | : 4,532 m ² |
| Height | : 173 m |
| Architecture firm | : Perkins and Will |
| Owner | : Mukesh Ambani |



Activity 1

Collect the interior views of various rooms in a residence.

1.7 Housing

A house is highly essential to protect us from rain, wind and heat. A proper housing is a must for today's social life. As roads and streets are considered important in an urban pattern, houses and their arrangements also attain importance.

Housing does not mean mere shelter. It includes hygienic, peace and good environment. Therefore urbanization should be kept in mind while planning for basic housing. When zoning is done for residential purposes, modern thoughts and predications regarding the future should be considered.

The success or failure of any urban pattern lies in the arrangement of housing in it. In any urban pattern, a large amount of area is allocated for residential purposes of the people. Based on the number of residential units, other facilities like roads, commercial complexes, etc., get their due share of land.

The majority of fund required for implementing basic amenities in a city, like drinking water, drainage, roads, etc., are collected from people in various forms of taxes. Therefore in any urban pattern, its revenue for administration depends on its population, commerce, income of people and so on.

Therefore a town planner should always plan well in advance and execute it in such a way to meet the residential demands of all categories of people.

1.7.1 Housing Demand

The factors that increase the housing demand are detailed below:

- i. If housing loans are available for a low interest rate, then the housing demand will increase.
- ii. It also depends on the availability of skilled labour. If good number of skilled labours are available, then the people will be inclined to construct houses without delay.
- iii. Availability of good road facilities is also one of the major reasons for housing development. For example, if a housing site is available in a place which doesn't have good roads, no one will be prepared to construct their houses in that area.
- iv. Real estate agents should develop plots in an area with all basic amenities and then sell it. Then only the people will tend to construct houses immediately.
- v. Huge population, less number of houses, surrounding environment and basic facilities are the reasons for increase in development of housing units.

1.7.2 Types of residential houses

- i. Detached houses or independent houses.
- ii. Semi-detached houses
- iii. Row houses
- iv. Apartments or flats
- v. Skyscrapers

i. *Detached houses or independent houses*

Houses which are alone and independent could be classified under this category.



Independent houses have good air circulation, ample lighting and there is always a feasibility for extending or modifying the existing house in its own land.

Houses of such type are constructed based upon the availability of lands and financial prospects. If the plots are available for a lesser price and if the construction materials are readily and cheaply available, then one could utilize such opportunities for the construction of detached houses. However such houses are luxurious and not thrift enough.

ii. *Semi-detached houses*

If an independent house is separated to accommodate two families, then it is considered as "Semi-detached house".

A common wall is used to separate the two houses. If sufficient frontage is



allowed in the front for both the houses, then it could be utilized in common by both the families.

iii. Row houses

Row houses are generally constructed for labourers and people working on daily wages. The reason is they are economical, suiting to their financial status.

Such houses will have only the minimum basic amenities. Bathrooms and toilets will be in common. Cost of such construction is very low. Therefore more number of people could be provided housing at lesser cost. Such row houses could be constructed with one or two floors.

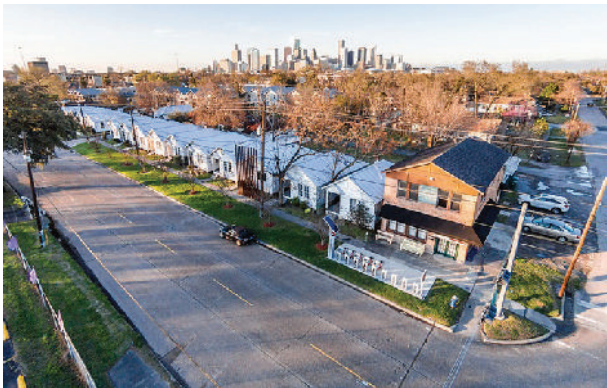

In prime locations and in congested localities of a city, it is difficult even for high income group people to purchase a plot and construct a house of their own. This lead to the construction of apartments or flats. Also people who like community living prefer apartments.

The cost of construction is much reduced when compared to the construction cost of an independent house. The reason is the cost of the land is shared and also the cost involved in common facilities is being divided among the families.

Disadvantages

- Not suited for large families with lot of children.
- Not possible to renovate, change, demolish and reconstruct the house.



Tallest building in India

Three Sixty West is a super tall skyscraper under construction in Mumbai, Maharashtra, India. It comprises two tower, joined at ground level by a podium. Tower B, the tall of the two, will rise to 372 metres (1,120 ft) and 85 floors and Tower A will be 260 metres (853 ft) and 53 floors. Tower A will be hotel and private residence will be located in Tower B. The podium will accommodate amenities such as restaurants and ballrooms.



iv. Skyscrapers

- Skyscrapers are generally buildings of many stories (more than fifty stories or 150 m) seeming to touch the sky when looked from the ground.

- In metropolitan and cosmopolitan cities, the cost of lands in major areas are too high and also rarely available. Therefore the technology of construction of residential buildings with several floors termed as skyscrapers came into existence and started developing.
- The main advantage of such tall buildings is that, its residents are free from the atmospheric pollution, particularly those who reside in the upper floors.
- Since skyscrapers are constructed vertically, the land beneath is better utilized in the sense that a small area of land is sufficient enough for large number of families to reside.
- But children and aged people find it difficult to negotiate the steps in skyscrapers and hence lifts or elevators become a must in such buildings.
- These skyscrapers are sometimes dangerous in localities through which microwave transmission are propagated and aeroplanes fly at low heights.
- Therefore before construction of skyscrapers various factors have to

be taken into consideration. Wind velocity and earthquake forces have to be definitely taken into account while designing such high rise buildings.



Activity 2

Collect the pictures of types of residential buildings



The biggest building in the world

The Izmailovo situated in Moscow, Russia has a total of 7,500 rooms. The whole unit is made up of four towers, 30 floors each. Each tower is given a name from the Greek alphabet - Alfa, Beta, Gamma, and Delta. The Olympic athletes were housed during the 1980 Olympiad in this hotel.





MODEL QUESTIONS



Part – I

Choose the correct answer. (1 Mark)

- _____ is a highly essential basic need of mankind.
 - Shelter
 - Vehicle
 - Pet animals
 - Road
- During ancient times man used to live in _____.
 - Trees
 - Dens
 - Row houses
 - Apartments
- _____ is not suited for gardening.
 - Clayey soil
 - Silty soil
 - Sandy soil
 - Loamy soil
- Dining hall should be placed adjacent to the _____.
 - Verandah
 - Bed
 - Bathroom
 - Kitchen
- People spend _____ of their lifetime in sleeping.
 - Half
 - One - Fourth
 - One - Third
 - One - Sixth
- Row houses are generally constructed for _____.
 - Labourers
 - Officers
 - Rich people
 - Politicians

Part – II

Answer in one or two sentences.

(3 Marks)

- Write short notes on grouping of rooms.
- Write short notes on sanitations of houses.
- List the rooms in a residence.
- List the types of residential houses?

Part – III

Answer in brief.

(5 Marks)

- What are the legal characteristics to be followed in choosing a plot?
- Write about the physical features to be considered during the site selection.

Part IV

Answer in detail.

(10 Marks)

- Explain about the Kitchen room.
- Explain Skyscrapers.

1. (a) 2. (b) 3. (c) 4. (d) 5. (c) 6. (a)

Answers

UNIT 2

SPECIAL BUILDING MATERIALS



“ Imagine what we could build together if we used faith, hope and love as our building materials? ”



Table of Contents

| | |
|--|--|
| 2.1 Introduction | 2.6 Aluminium |
| 2.2 Cement Concrete Composites | 2.6.1 Properties of Aluminium |
| 2.2.1 Light Weight Concrete (LWC) | 2.6.2 Uses of Aluminium as building material |
| 2.2.2 Autoclaved Aerated Concrete (AAC) | 2.7 Steel |
| 2.2.3 Fibre Reinforced Concrete (FRC) | 2.7.1 Types of Steel Reinforcement |
| 2.2.4 Self Compacting Concrete (SCC) | 2.7.2 Rolled sections – Structural Steel |
| 2.2.5 Ferrocement | 2.7.3 Stainless Steel |
| 2.3 Glass | 2.8 Miscellaneous materials |
| 2.3.1 Properties of Glass | 2.8.1 Admixtures in Concrete |
| 2.3.2 Uses of Glass as building material | 2.8.2 Damp proofing materials |
| 2.3.3 Special Glasses | 2.8.3 Fly Ash |
| 2.4 Rubber | 2.8.4 Plaster of Paris |
| 2.4.1 Uses of Rubber as building Material | 2.8.5 Sound Insulating Materials |
| 2.5 Unplasticized Polyvinyl Chloride (UPVC) | 2.8.6 Electrical Insulating Materials |
| 2.5.1 Advantages of UPVC | |

Learning Objectives

At the end of this lesson you shall be able to

- Understand various types of cement concrete composites and its advantages.
- Explain the properties, advantages and uses of various special building materials.
- List the miscellaneous materials used in building construction.
- Explain properties, types and advantages of miscellaneous materials.

2.1 Introduction

The building material used for centuries was stone and wood, later bricks. During the 19th century, cast iron and steel were used. The 20th century brought concrete and reinforced concrete into civil engineering field. The end of 20th century had significant use of cement concrete composites, plastic, glass, new forms of steel, aluminum and insulation materials.

2.2 Cement Concrete Composites

2.2.1 Light weight concrete (LWC)

Light weight concrete is made by using light weight aggregates like foamed slag, bloated clay, sintered fly ash, rice

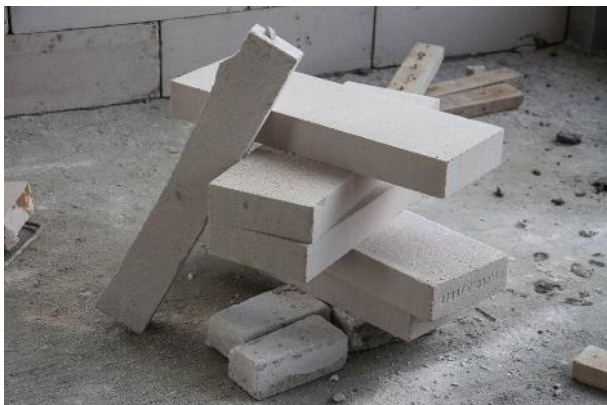
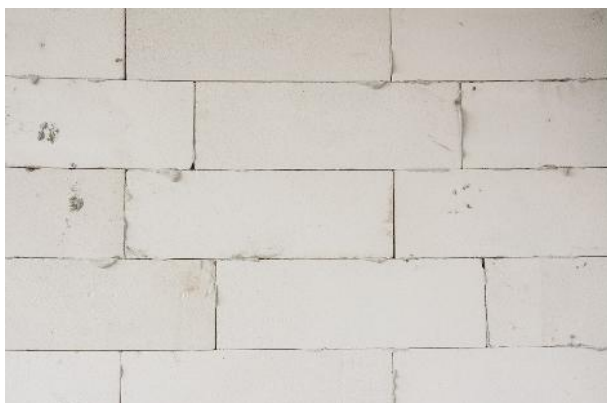

husk, etc. It is also achieved by introducing larger voids using aluminum powder or by omitting the fine aggregate from the concrete mix.

(i) Advantages of LWC

1. Light weight concrete reduces the dead load of the structure.
2. It increases the progress of construction of the structure.
3. It lowers the haulage and handling charges.
4. If walls and floors are made of light weight concrete, the foundations will be lighter resulting in considerable economy in the construction.
5. The thermal conductivity of light weight concrete is relatively low, which prevents the heat transfer from roof and walls, resulting lower temperature inside the building.
6. In case of buildings where air conditioning is to be installed, the use of LWC has been found advantageous both in thermal comfort and low power consumption.

2.2.2 Autoclaved Aerated Concrete (AAC)

AAC is a lightweight precast form concrete building material. It is composed of quartz sand, calcined gypsum, lime, cement, water and aluminium powder. Aluminum powder is used at a rate of 0.05%–0.08% by volume (depending on the pre-specified density). AAC products are cured under heat and pressure in an autoclave. The various forms of AAC are blocks, wall panels, floor and roof panels, cladding panels and lintels.



(i) **Advantages of AAC**

1. The most important advantage is its lower environmental impact.
2. Improved thermal efficiency reduces the heating and cooling load in buildings.
3. Excellent soundproofing material and acoustic insulator.
4. Highly fire and termite-resistant.
5. Manufactured in a variety of forms and sizes.
6. Reduces project cost.
7. Absorbs moisture from air and releases humidity.
8. Instalation of electrical and plumbing lines are easy.
9. Shipping and handling is more economical.
10. It is a durable material.

2.2.3 **Fibre Reinforced Concrete (FRC)**

The inherent weakness of concrete is development of micro-cracks due to drying shrinkage. The technique of using fibres in the mix help in overcoming this weakness to a great extent. Fibre Reinforced Concrete is a composite material consisting of cement mortar or concrete with uniformly distributed discrete fibres of high tensile strength.



The various types of fibres used in FRC are steel, Polypropylene, Nylon, Asbestos, Coir, Glass, Carbon, etc.

(i) **Advantages of FRC**

1. It increases the tensile strength of the concrete.
2. It reduce the voids in concrete.
3. It increases the durability of the concrete.
4. It has been recognized that the addition of small, closely spaced and uniformly dispersed fibres to concrete would act as crack arrester.
5. Improve its static and dynamic properties.

2.2.4 **Self Compacting Concrete (SCC)**

Self compacting concrete is highly flowable, non-segregating concrete that can spread into place, fill form work and encapsulate the reinforcement without any mechanical consolidation. The spread of self compacting concrete typically ranges from 1 to 32 inches depending on the requirements for the construction. Materials used for self compacting concrete are cement (43 or 53 grade), aggregates (less than 20 mm), Water and super plasticizers (chemical admixtures).



World's Longest Bridge Over Water

The bridge spans Jiaozhou Bay, on the sudden coast of China's Shandong peninsula in north eastern China. It travels 26.4 miles long. Chinese workers finished this construction in four years, starting at each side and meeting in middle. The structure has 5,200 pillars and cost 2.3 billion dollars.



(i) Advantages of SCC

- No need of mechanical vibrators.
- Faster construction improve working conditions.
- Greater freedom in design.
- Less noise due to absence of mechanical vibrators.
- Improves the quality, durability and reliability of concrete.

2.2.5 Ferrocement

Ferrocement is defined as a thin walled reinforced concrete. It is reinforced with small diameter wire mesh instead of steel rods. Wire mesh is usually made of steel 0.8 to 1.0 mm diameter with 5 to 50 mm spacing. The CM generally used is in ratio of 1:2 or 1:3.



(i) Properties of ferrocement

1. It has high strength per unit mass.
2. It has good capacity to resist shock.
3. Highly versatile form of reinforced concrete.
4. It does not need form work.
5. It is impervious.

(ii) Uses of ferrocement

1. Partition wall.
2. Window frames, shutters, sunshades, etc.
3. Cupboard shelves.
4. Precast roof elements.
5. Domestic water tank.
6. Furniture.
7. Manhole covers.
8. Boats.

2.3 Glass

Glass is a hard, brittle, transparent or translucent material. It is used in numerous applications in our daily lives. Glass is made from natural and abundant raw materials (sand, soda ash and lime stone) that are melted at very high temperature.



Activity 1

Collect pictures of special glasses and prepare an album

2.3.1 Properties of glass

1. It absorbs, refracts and transmits light.
2. It can take up a high polish.
3. It has no definite crystalline structure.
4. It has no sharp melting points.
5. It is an excellent electrical insulator.
6. It is available in beautiful colours.
7. It is usually unaffected by air or water.
8. It has excellent resistance to chemicals.
9. When it is heated, it becomes softer and ultimately transformed into liquid.

2.3.2 Uses of glass as building material

1. Glass can be used for window panels.
2. Glass blocks can be used for partitions.
3. Structural glass can be used for insulation, panel walls, wall facings enclosures, etc.

4. Potash lead glasses are used for making electric bulbs.
5. Tinted glass can be used for decorative glass works.
6. Fibre glass reinforced plastics can be used to construct furniture, lamp shades and bathroom fittings.

DO
YOU
KNOW?

World's Tallest and Longest Glass Bridge

World's tallest and longest glass bridge is in China. The length of the bridge is 430 m. It was opened on 20th August 2016.

Zhangjiajie Grand Canyon

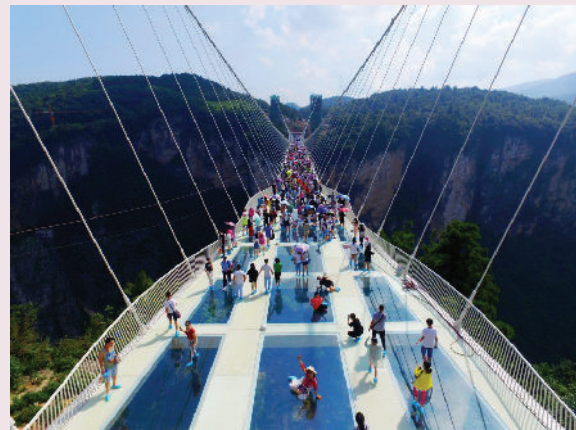

2.3.3 Special glasses

The following are some of the special glasses.

1. Fibre glass
2. Foam glass
3. Bullet proof glass
4. Structural glass
5. Glass block
6. Wired glass
7. Ultraviolet ray glass
8. Perforated glass

2.4 Rubber

Rubber is also known as Elastomer. It is produced as a natural product from rubber trees and also manufactured by chemical processes. The former is known as natural rubber and the latter is synthetic rubber. Natural rubber has high strength and good resistance to tear as well as flexure. However it is easily affected by solvents.

It is widely used in the construction industry, for sealing, shock absorption, electrical insulation, fire-proof insulation, in expansion joints, etc.



2.4.1 Uses of Rubber as building materials

The general uses of rubber as a building materials are as follows:

1. Rubber is used as a gasket to make doors and windows air tight.
2. Rubber latex is used for bonding rubber to metal, wood and similar surfaces.
3. It is used as shock absorber in construction work like bridge, etc.
4. Rubber is used as a sealant in water-retaining structures.
5. Rubber can be used as a joint filler.
6. Rubber is also used for flooring in buildings.

7. Rubber coatings and linings are used for corrosion protection in offshore engineering.
8. Rubber can be used as sound absorbers.

2.5 Unplasticized Polyvinyl Chloride (UPVC)

Regular PVC (Poly vinyl Chloride) is a common, strong, but light weight plastic used in construction. It is made softer and more flexible by the addition of plasticizers. If plasticizers are not added, it is known as UPVC (Unplasticized Polyvinyl Chloride).

2.5.1 Advantages of UPVC

- Gives perfect insulation (from heat and cold).
- Highly hygienic.
- No maintenance required.
- Sound proof.
- Available in various colour and sizes.
- Not affected by atmospheric agencies.
- Easy to clean.
- Safe and easy to operate.
- Not affected by insects.





Activity 2

Prepare an album of UPVC doors and windows.

2.6 Aluminium

Aluminium is the world's most abundant metal and is the third most common element, comprising 8% of the earth's crust. But it is commercially produced mainly from bauxite which is hydrated oxide of Aluminium. The versatility of Aluminium makes it the most widely used metal after steel.



2.6.1 Properties of Aluminium

1. It is a good conductor of heat and electricity.
2. It is rarely attacked by nitric acid, organic acid or water.
3. It is highly resistant to corrosion.
4. It is light in weight, malleable and ductile.
5. It is a soft metal.
6. The melting point of aluminium is about 658°C.
7. It possesses great toughness and tensile strength (124-290 N/mm²).
8. Its specific gravity is about 2.70.

2.6.2 Uses of Aluminium as Building Material

Aluminum is used as an important building material especially in developing countries. The following are the important properties of aluminum that make it useful as a building material.

1. **Air tightness:** A well-designed aluminium door, window, etc., is perfectly airtight and sealed for dust and rain water.
2. **Appearance:** The finished aluminium will be having a pleasing appearance and depending on the decorative style of the building, shades of various colours can be selected.
3. **Ease in fabrication and assembly:** As aluminium is comparatively soft and ductile, the fabrication of doors, windows, etc., can be easily carried out. It can be easily dismantled, transported and re-erected.
4. **Handling and transport cost:** Aluminium is very light and hence the handling and transport cost is very low.

5. **High corrosion resistance:** Aluminium has excellent corrosion resistance and it can resist weathering actions in extremely humid and dry conditions.
6. **High scrap value:** The scrap value of aluminium is very high.
7. **Maintenance cost:** Due to high corrosion resistance, its maintenance cost is very low.
8. **Noise control:** Aluminium is an excellent reflector of electromagnetic and sound waves. It is less affected by external noises as compared to buildings made from other materials.

2.7 Steel

Steel is an alloy of iron, carbon and other elements. Because of its high tensile strength it is a major component used in buildings, infrastructures, tools, ships, automobiles, machines, appliances and weapons. Iron is the base metal of steel.

The important market forms of steel used in building construction are as follows.

1. Steel bars of many shapes and grades or strengths. (These bars are used for reinforced concrete and also for fabrication of grills, gates, etc.)
2. High tensile steel for pre-stressed concrete work.
3. Various shapes of I, channel, angle, plates and other rolled section for structural fabrication.
4. Cold formed light gauge structural steel sections.
5. Stainless steel for special uses.

2.7.1 Types of steel reinforcement

Steel rods used for reinforced concrete work should be of specified tensile strength and they should develop good bond with concrete. There are different types of steel like mild steel, Tor steel, TMT bars, etc. Steel rods of different diameter are used for R.C work.



The following types of bars are commonly available in market for reinforced concrete construction.

1. Hot rolled steel bars
 - i. Hot rolled plain round mild steel bars.
 - ii. Hot rolled ribbed mild steel bars (generally not recommended for use).
 - iii. Hot rolled high strength deformed (HYSD) bars.

2. Hot rolled cold twisted deformed (CTD) bars like Tor steel bars. High strength is achieved by cold twisting.
3. Thermo mechanically treated (TMT) bars. High strength is achieved by controlled cooling.

2.7.2 Rolled Sections- Structural Steel

The two main types of structural steel members are:

- (i) The conventional hot-rolled steel sections.
- (ii) Cold- formed steel sections.

(i) Hot- rolled steel sections

Steel used for fabrication of trusses, column, beams, etc., is made by rolling hot steel into various shapes in specially designed rolling mills. Hot rolled steel sections are illustrated in figures. The various sections available are as follows:

1. **Angle sections:** Various sizes of equal and unequal angle sections are available. They are mainly used for truss work and filler joist floors.
2. **Channel sections:** Bureau of Indian Standards classifies channels as junior channels (ISJC), light channels (ISLC) and medium channels (ISMC). They are used widely for steel framed structures.
3. **I sections:** These sections are called rolled steel joists or beams. They are classified as Indian standard junior beam (ISJB), Indian standard light beam (ISLB), Indian standard

medium beam (ISMB), Indian standard wide flanged beams (ISWB) and Indian standard heavy beam (ISHB). They are used in multistoried buildings, bridge and other places where bending stresses are very high.

4. **T sections:** These sections are used to make built up sections and roof girders.
5. **Other rolled sections:** Plain sheets, corrugated sheets, plates, expanded metal, sheet piles, rail sections, flats of varying width and thickness are also rolled in rolling mills. They are used for fabrication.



(ii) Cold-formed steel sections

Cold formed light gauge steel sections are structural members, cold formed to the desired structural shapes from carbon or alloy steel (strips or flats) by press- brake operations. The thickness of the member ranges from 0.38 to 6.35 mm. They have much higher strength than hot-rolled sections.

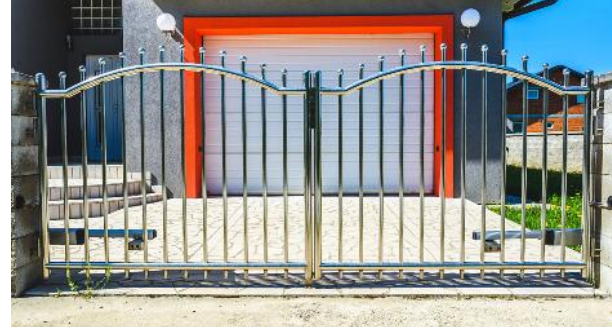

The advantages of the cold formed steel sections over hot rolled sections are:

1. Cold formed steel sections are thinner so that we can get more length of the material from the same weight of steel.
2. A more economical design for light loads and moderate spans can be made from these sections.
3. A more favorable strength to weight ratio can be achieved through these sections.
4. Aesthetically pleasing box sections can be made for fabrication. This can be made to look as wood by necessary painting (or) other treatments.
5. Cold formed steel sections have higher strength than hot rolled steel sections. These are extensively used in fabrication of roof trusses.



Activity 3

Collect various types of rods and rolled steel sections and display it in your class room.

2.7.3 Stainless steel

Stainless steel is a general term given to certain alloys of iron, chromium and nickel. This type of steel has high resistance to corrosion. It is designated by the percentage of chromium and nickel. Example: 18-8 stainless steel indicates 18 percent chromium 8 percent nickel.

(i) Advantages of Stainless steel

The following are the advantages of using Stainless Steel.

- Life-cycle cost benefits.
- Excellent corrosion resistance.
- 100% Recyclable.
- 80% Recycled content.
- High ductility and strength.
- Non-magnetic.
- Excellent high and low temperature properties.
- Resistance to unsightly staining.
- Aesthetic surface finish.

2.8 Miscellaneous Materials

2.8.1 Admixtures in Concrete

Concrete is the most versatile material in the construction field. In order to modify the properties of concrete so as to make it more suitable under a wide range of climatic conditions and circumstances, admixtures are used in concrete.

Admixtures are the ingredients in concrete other than water, aggregates and cement that added to the mix batch immediately before or during mixing.

The following are the commonly used Admixtures

- (i) Water reducing Admixtures
- (ii) Air entrained Admixtures
- (iii) Setting and hardening Admixtures

(i) Water reducing Admixtures

Water reducing admixtures are used in concrete to reduce the quantity of mixing water. Desired slump, required consistency, high early strength, better durability can be achieved by adding this admixture. Plasticizers and super plasticizers are commonly used water reducing admixtures.

(ii) Air entrained Admixtures

Air entraining admixtures are generally used for increasing the workability and resistance to freezing and thawing (Frost resistance) in concrete. These admixtures generate air bubbles to facilitate frost protection. Natural wood resins, animal and vegetable fats and oils, hydrogen peroxide and aluminium powder are the commonly used air entraining admixtures.

(iii) Setting and Hardening Admixtures

1. Set Retarders

These agents are primarily used for delaying the setting time of concrete. The most common retarder is calcium sulphate

or gypsum, which is used as an ingredient in the manufacture of Portland cement.

2. Set Accelerators

An accelerating admixture is a material added to the concrete for the purpose of shortening the setting time and accelerating early strength development of concrete. Soluble chlorides, carbonates, silicates and alumina have been used for this purpose.

2.8.2 Damp Proofing Materials

Damp proofing in construction is a type of moisture control applied to building walls and floors to prevent moisture from passing into the interior spaces. Dampness is the most frequent problems encountered in residences.

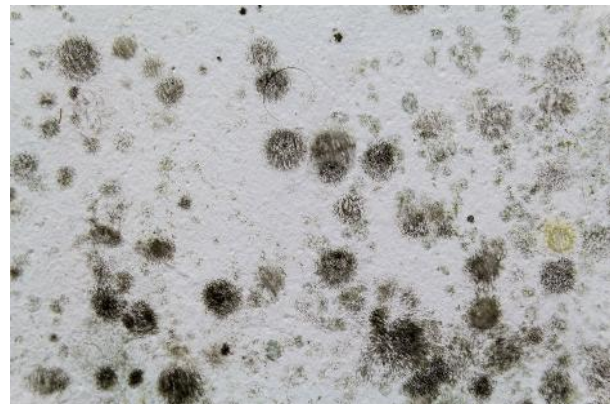

(i) Properties of damp proofing materials

An effective damp proofing material should have the following properties

1. It should be impervious.
2. It should be strong and durable.
3. It should be capable of withstanding both live and dead loads without damage.
4. It should be stable.
5. The material should be reasonably cheap.



(ii) Classification of damp proofing materials

The materials commonly used to prevent dampness can be classified into the following four categories

- (1) Flexible material
- (2) Semi rigid materials
- (3) Rigid materials
- (4) Grout materials



1. Flexible materials like butyl rubber, hot bitumen (asphalt), plastic sheets, bituminous felts, sheets of lead, copper, etc.
2. Semi-rigid materials like mastic asphalt.
3. Rigid materials, like impervious brick, stone, slate, cement mortar, or cement concrete painted with bitumen, etc.
4. Grout material like mortar with waterproofing compounds.

2.8.3 Fly ash

Fly ash is obtained by combustion of coal in thermal power plants. Fly ash is a pozzolana, containing aluminous and siliceous material that forms cement in the presence of water. When mixed with lime and water, fly ash forms a compound similar to Portland cement. This makes fly ash suitable as a prime material in blended cement, mosaic tiles, and hollow blocks, among other building materials. When used in concrete mixes, fly ash improves the strength, durability and makes it easier to pump.

(i) Fly ash bricks

Fly ash bricks, is competitive when compared to the conventional clay bricks, as it provides enormous indirect benefits.



The utilization of fly ash bricks results in conservation of natural resources as well as protection of environment. These bricks are manufactured by mixing quarry dust / river sand, stone aggregates less than 6 mm in size, cement and fly ash. (Fly Ash quantity will be 10% to 20% of Cement).



Activity 4

Visit a fly ash bricks manufacturing unit nearby your location and prepare a report about the manufacturing process

Flow chart showing the manufacture of fly ash bricks

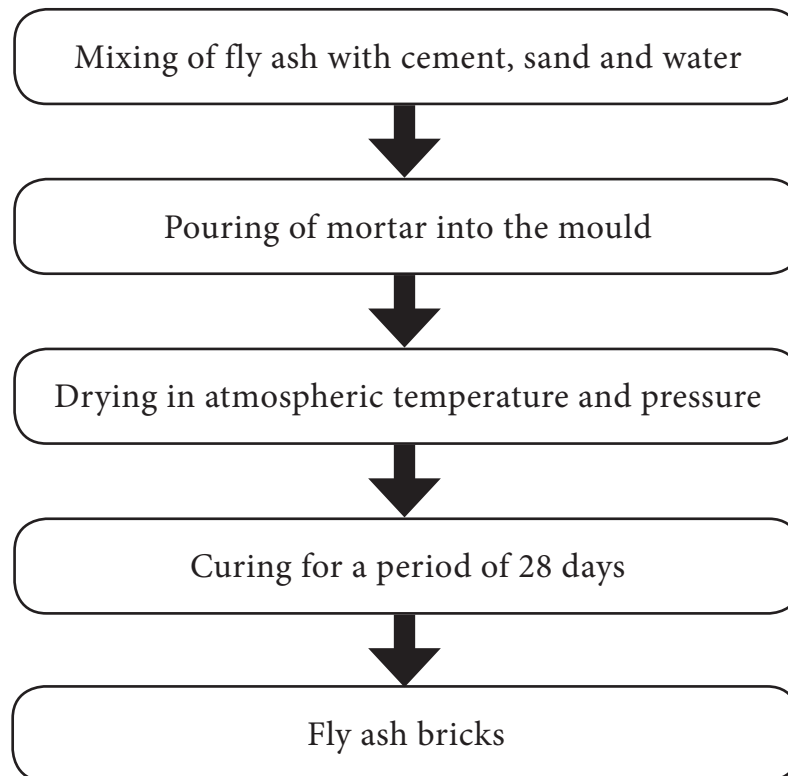



(ii) Advantages and Disadvantages of Fly ash bricks

Advantages

1. It reduces dead load on structures due to light weight (2.6 kg, dimension: 230 mm X 110 mm X 70 mm).
2. High fire Insulation.
3. Due to high strength, practically no breakage during transport and use.
4. Due to uniform size of bricks, mortar required for joints and plaster reduces almost by 50%.
5. Due to lower water penetration, seepage of water through bricks is considerably reduced.
6. Gypsum plaster can be directly applied on these bricks without a backing coat of lime/cement plaster.
7. These bricks do not require soaking in water for 24 hours. Sprinkling of water before use is enough.

Disadvantages

1. Mechanical strength is low, but this can be rectified by adding mortar between blocks.
2. Limitation of size. Only modular size can be produced. Large size will have more breakages.
3. It is only good for the places like subtropical area or area where climate is warm because it doesn't absorb heat. But during cold it is not helpful.

2.8.4 Plaster of Paris

It is a kind of hydrated gypsum. When mixed with water, it slakes and generates heat and expands to certain extent. It is milky white in color and used for making moulds, filling gaps in

masonry and plaster. It is mainly used for decorative false ceiling works in all types of buildings.



(i) Advantages and Disadvantages of Plaster of Paris

The following are the advantages of using Plaster of Paris.

1. It does not shrink while setting and thus avoids cracks.
2. It is durable and light weight.
3. It combines well with paint and helps in decoration of walls.
4. It is easily workable as it mixes with water.



5. It has high resistance to heat and can be made as insulating material.
6. It has low thermal conductivity.
7. It can be moulded into various shapes.
8. It also sticks well to fibrous surfaces.
9. It does not interact chemically with paint and prevents alkali attack.
10. Its gypsum content provides smoothness and shine.

Disadvantages of Plaster of Paris

The following are the disadvantages of using Plaster of Paris:

1. Gypsum plaster is not suitable for exterior finish as it is slightly soluble in water.
2. It is more expensive than cement or cement-lime plaster.
3. It cannot be used in moist situations.
4. Skilled labour is required for precise application and thus labour cost for applying plaster of Paris is high.

2.8.5 Sound Insulating materials

Noise due to traffic, aircraft, barking dogs., equipment, machinery, etc., affects our peaceful and quiet living atmosphere. These divert our concentration resulting in stress, fatigue and less productivity. To overcome these problems, some type of sound insulating materials have to be used in the construction.

On the basis of acoustic properties, materials can be divided in to the following groups:

1. Sound reflection materials
2. Sound absorbing materials
3. Sound insulation materials

1. Sound reflection materials

These materials are generally placed in the ceiling, back of the stage and side walls of lecture halls. Materials such as wood, special plaster and concrete are sound reflection materials. The sound reflection property of materials is expressed by their sound reflection coefficients.

2. Sound absorbing materials

Absorption is expressed by the absorption coefficient. The materials with loose structure such as carpets, wool mats, perforated hard boards (where the sound energy is lost in the holes), etc., are called typical sound absorbing material.

3. Sound insulation materials

Dense materials such as bricks do not allow sound to pass through. There are many types of construction such as solid brick walls, cavity walls, double wall partitions with sound absorbing materials in between. The sound insulation property of a material is expressed by the reduction of noise in decibel.

2.8.6 Electrical insulating materials

The material which does not allow the electricity to pass through them is known as electrical insulating material. It provides the high resistive path to the electric current through which it is impossible to pass through. It is also used in the overhead transmission line.

The commonly used electrical insulating materials are glass, plastic, rubber and wood.

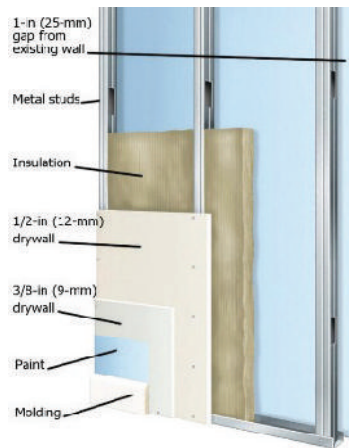
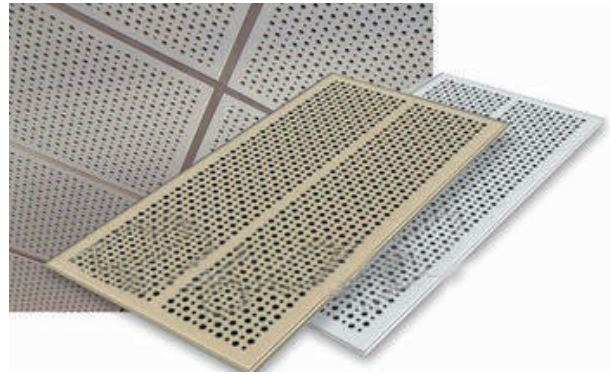

(i) *Properties of Electrical Insulating materials*

The insulating material should have the following properties.

1. The material must have high mechanical strength.
2. They must have high dielectric strength.
3. The material is highly resistive in preventing the flow of leakage current from the conductor to earth.
4. This material should be non porous and free from impurities.
5. The electrical and chemical property of the material should not be affected by the temperature.



MODEL QUESTIONS



Part – I

Choose the correct answer. (1 Mark)

- _____ concrete reduces the dead load of the structure.
 - Auto claved Aerated
 - Ready mix
 - light weight
 - Fibre reinforced
- Ferrocement is defined as a _____walled reinforced concrete construction.
 - Thin
 - thick
 - double
 - cross
- Aluminium is a good conductor of _____ and electricity.
 - cool
 - heat
 - light
 - very cool
- An admixture is a material other than _____, aggregates and cement used in concrete making.
 - oil
 - steel
 - water
 - wood
- Fly ash bricks are competitive in comparison to the conventional _____ bricks.
 - Clay
 - glass
 - steel
 - light weight
- Gypsum plaster is _____ expensive than cement or cement lime plasters.
 - more
 - less
 - moderate
 - very low

Part – II

Answer in one or two sentences

(3 Marks)

- What is light weight concrete?
- List few fibres used in fibre reinforced concrete.
- Write a short note about glass.
- What are the materials commonly used for electrical insulation?
- Write short note on stainless steel.

Part – III

Answer in Brief

(3 Marks)

- What is ferrocement? Write its properties.
- What are the two main types of structural steel members and explain about any one?
- Describe the classification of Damp proofing materials.
- What are the advantages and disadvantages of fly ash bricks?

Part – IV

Answer in detail

(10 Marks)

- Explain about Rubber and its uses in building.
- Write briefly about Admixtures in concrete.
- Write about plaster of Paris and mention its advantages and disadvantages.

1. (a) 2. (c) 3. (a) 4. (b) 5. (c) 6. (a)

Answers

UNIT 3

SURVEYING



“ The best preparation for tomorrow is doing your best today. ”

H. Jackson Brown, Jr.



Table of Contents

3.1 Introduction to Surveying

- 3.1.1 Definition
- 3.1.2 Divisions of Surveying
- 3.1.3 Classifications of Surveying
- 3.1.4 Uses of Surveying

3.2 Chain Surveying

- 3.2.1 Definition
- 3.2.2 Purpose of Chain surveying
- 3.2.3 Operations in Chain surveying
- 3.2.4 Instruments used in Chain surveying
- 3.2.5 Ranging
- 3.2.6 Obstacles in Chain surveying
- 3.2.7 Errors in Chaining

3.3 Levelling

- 3.3.1 Definition
- 3.3.2 Basic terms used in levelling
- 3.3.3 Benchmark and its types
- 3.3.4 Instruments used in levelling
- 3.3.5 Different types of levels
- 3.3.6 Setting up instrument
- 3.3.7 Levelling staff
- 3.3.8 Reduction of Levels

3.4 Advancements in Surveying

- 3.4.1 Introduction
- 3.4.2 Total Station (TS)
- 3.4.3 Global Positioning System (GPS)
- 3.4.4 Geographic Information System (GIS)

Learning Objectives

At the end of this lesson you shall be able to

- Know the Objectives, Classifications and Uses of surveying
- Understand the purpose of Chain surveying
- State the various instruments used in Chain surveying
- Explain levelling and list the instruments used in levelling
- Know the advancements in Surveying.

3.1 Introduction to Surveying

3.1.1 Definition

Surveying is an art of determining the relative positions of different points on,

above or beneath the surface of the earth by means of direct or indirect measurements of distance, direction and elevation.

3.1.2 Divisions of Surveying

Surveying is broadly classified into two primary divisions.

- a. Plane surveying
- b. Geodetic surveying

a. Plane surveying

When the extent of area surveyed is comparatively small, then the effect of curvature is not considered as the surface of the earth is assumed to be flat or plane is called plane surveying.

b. Geodetic surveying

When the extent of area surveyed is large or degree of accuracy required is more, then the effect of curvature of earth is taken into consideration and the survey is called geodetic surveying. It is also known as trigonometrical survey. In our country it is carried out by the great trigonometrical department of India.

3.1.3 Classification of Surveying

The detailed classification of surveying is shown in the a flow chart below.

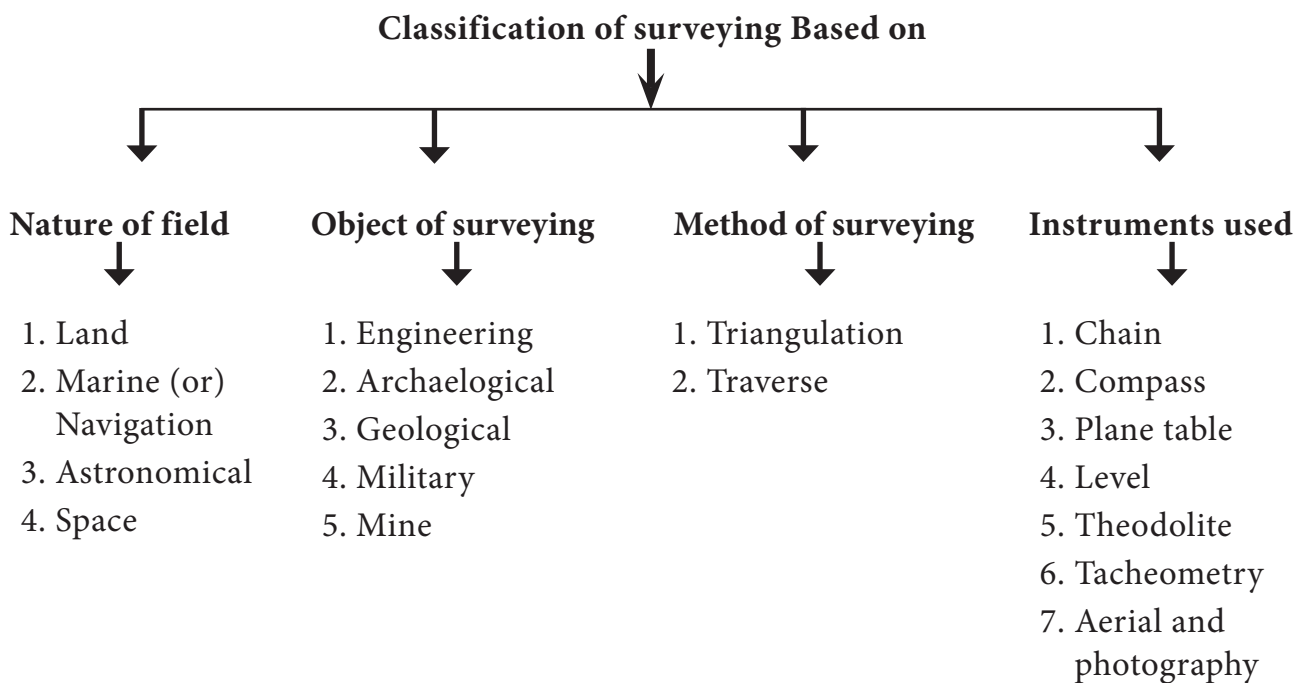

3.1.4 Uses of Surveying

Some of the uses of surveying from engineer's point of view are as follows

1. To know the relative position and shapes of the area to be surveyed (hills, valleys, lakes, rivers, etc.)
2. To establish boundary lines of property.
3. To find the areas of boundary, catchment, ayacut, etc.
4. To calculate the volumes of earthwork in cutting and embankment, capacity of reservoir, etc.
5. To select suitable alignment for engineering works (roads, railway, canal, bridge, etc.) and to locate the same properly.
6. To determine the suitability of a site for any engineering work
7. To collect data for planning, analysis, design, cost estimation, etc.

- To execute engineering works for proper management.

3.2 Chain Surveying

3.2.1 Definition

Chain surveying is the simplest process of measuring distances with a chain. It is also called chaining.

3.2.2 Purpose of Chain surveying

- To secure data necessary for making a plan.
- To secure data for exact description of boundary of land.
- To determine the area of land.
- To divide a piece of land into a number of units.

3.2.3 Operations in Chain surveying

- Ranging
- Chaining
- Offsetting



3.2.4 Instruments used in Chain surveying

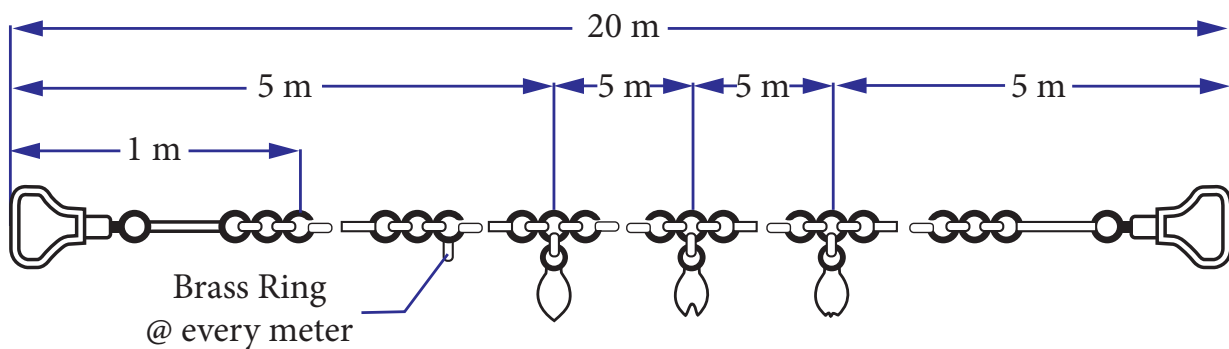

- Chain
- Tape
- Arrows
- Pegs
- Ranging rods
- Offset rods
- Plumb bob
- Cross staff
- Optical square
- Field book

1. Chain

A chain may metric or non metric. Generally a chain is divided into 100 links or 150 links. The links are made by galvanized iron (or) steel wires of 4 mm to 6 mm diameter. The ends of the links are bent into a loop and connected to a circular or oval rings. The ends of the chain are provided with a swivel jointed brass handle as shown in figure.



-  Brass Ring at Every meter length
-  Tally at 5 m length

-  Tally at 10 m length
-  Tally at 15 m length

Details of metric chain

Types of chain

- a. Metric chain:** Metric chains of length 5 m, 10 m, 20 m, 30 m are in use. Every metre is divided into 5 links each of length 0.2 m.

The length of the link is the distance between the centre of the two consecutive middle links. Small brass rings are provided at every metre and tallies at every 5 m length.

- b. Non metric chain:** The following are the non – metric chain in which the unit of measurement is in foot.

- i. Engineer's chain:** Engineer's chain is 100 feet long and is divided into 100 links, each link is being one foot long.

- ii. Gunter's chain (or) surveyor's chain:**

Gunter chain is 66 feet long and is divided into 100 links, each link is being 0.66 feet long.

- iii. Revenue chain:** Revenue chain is 33 feet long and is divided into 16 links.

Note: The above non – metric chains are not in use nowadays. They have become obsolete.

- c. Steel bands:** It is a steel ribbon with a brass swivel handle at each end. It is 3 to 16 mm wide, 20 to 30 m long and 0.2 to 0.6 mm thick. It is light weight and easy to handle

2. Tapes

Tapes are made of different materials.

The following are some of the tapes commonly used:

- a. Linen (or) cloth tape
- b. Glass fibre tape

- c. Metallic tape
- d. Steel tape
- e. Invar tape



■ Glass fiber tape

It is made of glass fiber and PVC. It is flexible, strong and durable. It does not stretch or shrink due to change in temperature and dampness. It is available in varieties of lengths.

■ Steel tape

It is made of steel (or) stainless steel and used for accurate measurements. It is available in lengths of 5 m, 10 m, 20 m and 50 m.

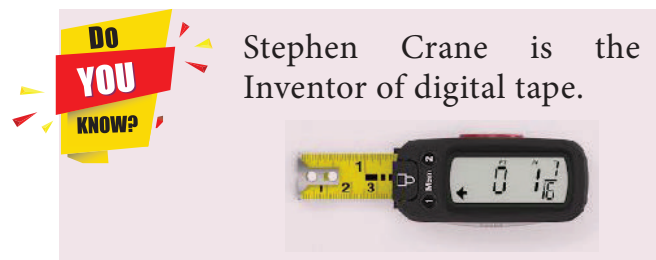

3. Arrows

These are made of hardened and tempered steel wires of 4mm diameter and length of 400 mm. These are pointed at one end and other end is bent to a circle of diameter 50 mm.

Arrows are used to mark the points on the ground or end of chain lengths and to note the number of chains measured during the chaining process.

4. Pegs

Pegs are made of wood. These are 25 mm square and 150 mm long, tapered at one end. It is used to mark the survey stations by driving it into the ground. Iron or steel pegs of 12 mm diameter can also be used as pegs.

5. Ranging Rods

Ranging rods are made of well seasoned, straight grained timber or steel tubular rods.

These are circular (or) octagonal in cross section of 25 mm diameter and 2 m or 3 m long. The bottom end is tapered and fitted with a metal shoe to insert it into the ground. They are painted with alternate bands of red and white (0.2 m band length). A flag can also be attached to the top of the ranging rod.

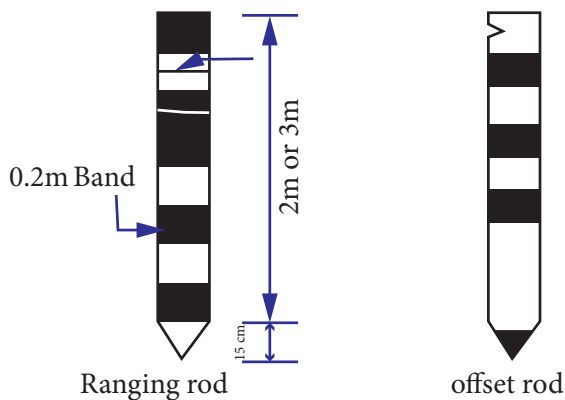

Ranging rods are used to locate the survey stations and to range the survey lines.

6. Offset rods

It is similar to ranging rod. It is provided with a recessed hook for pulling the chain through any obstruction.

It can be used for locating stations and ranging the lines.

7. Plumb-bob

It is made of steel in conical shape with a thread connected at the centre.

Generally it is used for centering a station point.

While measuring distances on the sloping ground, it is used to transfer the point to the ground by suspending the plumb bob.



Plumb-bob

8. Cross Staff

Cross staff is used for

- i. Establishing perpendicular offset from a given point to a line
- ii. Setting out a right angle at a given point on a line

The two forms of cross staff commonly used are:

- a. Open cross staff
- b. French cross staff

a. Open cross staff
It consists of two pairs of vertical slits providing two lines of sight mutually at right angles. Each pair consists of two vanes, one is eye vane and the other is objective vane.

- b. **French cross staff**

It consists of an octagonal brass tube with slits on all eight sides. It has an alternate vertical slit and an opposite vertical window, with a vertical cross hair

on each of the four sides. These are used for setting out right angles.

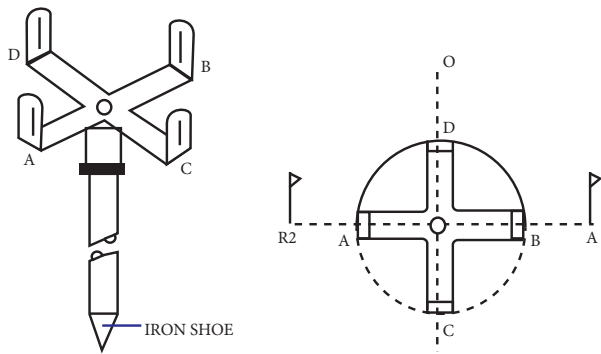

Open cross staff



French cross staff



Activity 1

Collect pictures of various chain surveying instruments and prepare an album.

9. Optical Square

Optical square is an instrument used to construct perpendicular to a chain line.

It is circular in shape of 50 mm radius and 125 mm height. It has a sliding lid which cover the instrument when it is not in use.

As shown in figure, there are two reflecting mirrors H and I fixed at an angle of 45° to each other. The mirror H is half silvered and the mirror I is completely silvered. The three slits in the instrument

are S_1 for eye sight S_2 is horizontal sight for ranging the station and S_3 is the index sight perpendicular to slits S_1 and S_2

The image of the ranging rod fixed at 'p' falls in the mirror I and gets reflected to the silvered portion of mirror H and reaches eye of the observer.

The ranging rod B can be viewed by the observer directly through the unsilvered portion of the mirror H. The ranging rod at 'P' is adjusted until the images of these two ranging rods coincide. Now the perpendicular is set for the chain line.

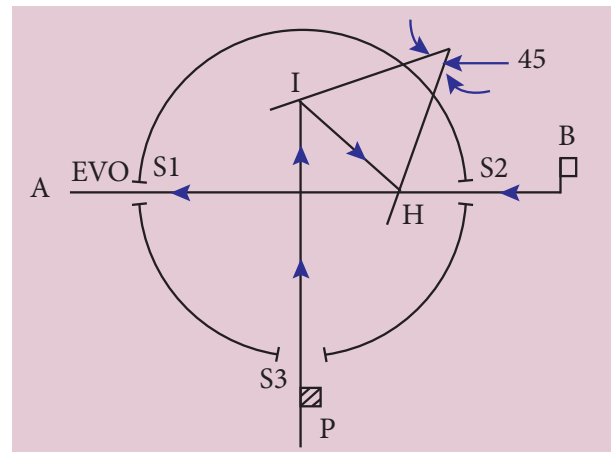

Optical Square

3.2.5 Ranging

The process of establishing intermediate points on a straight line between terminal points is known as ranging.

If the line is short (or) end of the station is clearly visible, it is easy to put the chain in the true alignment. But, if it is long or the end station is not clearly visible, it is necessary to place intermediate ranging rods to maintain the direction. It may be done by eye (or) instrumentally by using a line ranger.

Types of ranging

Ranging is of two types namely,

1. Direct ranging
2. Indirect ranging

1. Direct ranging:

When the intermediate ranging rods are placed in line by direct observation then it is called Direct ranging. It is possible only when the end stations are mutually intervisible.

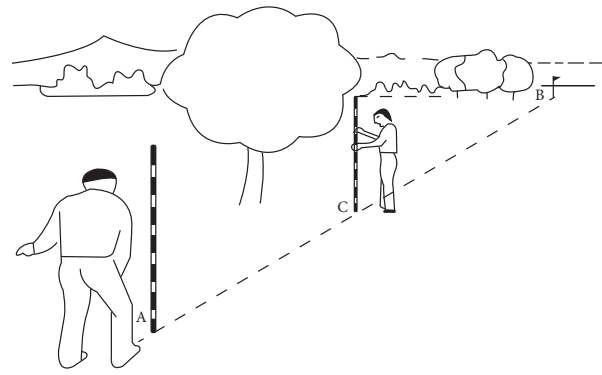

Direct ranging

2. Indirect ranging

When the end stations of survey line are not mutually intervisible then it is called indirect ranging. It may be due to an intervening hill or a valley or an obstacle such as tall building or a thick wooded forest, etc. It is also called as Reciprocal ranging.

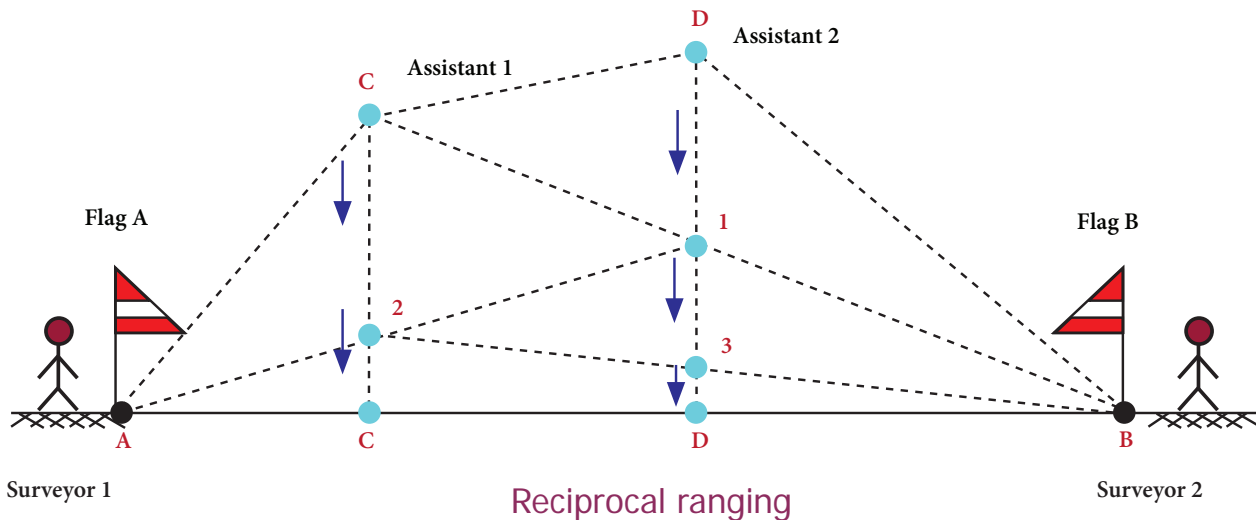

Reciprocal ranging

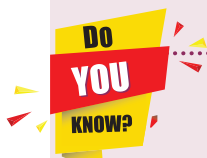

Microwave Instruments - Distance measurer

These instruments make use of high frequency radio waves. These instruments were invented as early as 1950 in South Africa by Dr. T. L. Wadley. The range of these instruments is up to 100 km and can be used both during day and night. It is used in surveying to measure the distances. E.g. Tellurometer



3.2.6 Obstacles in chain surveying

Obstacles prevent direct measurement of distances between the points and pose problems. Hence the distances are to be found by indirect measurement.

There are three types of obstacles

1. Obstacles to ranging
2. Obstacles to chaining
3. Obstacles to both ranging and chaining

1. Obstacles to ranging

This type of obstacle in which the ends are not intervisible, but the distance between the points can be measured.

Example: rising ground, hill, wooded forest.

2. Obstacles to chaining

In this method chaining is obstructed but the two end points are intervisible. Obstacles to chaining are pond, river, lake and plantations.

There are two cases of this obstacle.

- i. When it is possible to chain round the obstacle.
- ii. When it is not possible to chain round the obstacle.

Case (i) When it is possible to chain round the obstacle.

In obstacles to chaining like lake, pond, hedge, etc.

1. Select two points in A & B on either side of the obstacle.
2. Erect two perpendiculars AC and BD from stations A and B. i.e., $AC = BD$.
3. Join C and D and measure the distance between them.
4. The distance CD is equal to AB.

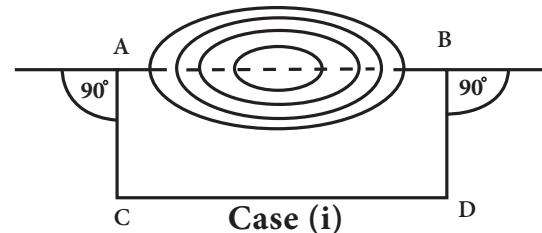

Case (ii) Impossible to chain round the obstacle

In obstacles to chaining like river, stream etc.

1. Select two points A and B on either side of the obstacle.
2. Erect perpendicular AC and bisect it at D.
3. Erect perpendicular CE at C and range E in line with BD.
4. Measure CE That is equal to AB ($CE=AB$)

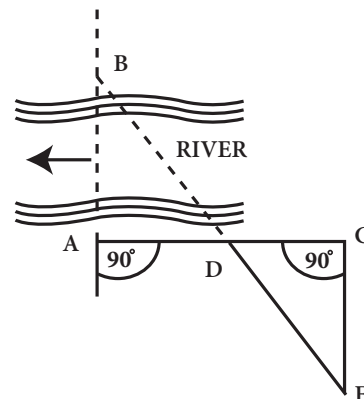

Case (ii)

3. Obstacles to both chaining and ranging

In this case, the following procedure is adopted to determine the obstructed distance. A tall building is a typical example.

1. Choose A and B on one side of the obstacle.
2. Erect perpendiculars AC and BD of equal length.
3. Join CD and prolong it to pass through the obstacle.
4. Choose E and F on CD erect the EG and FH equal to that of AC and BD. Join GH and prolong it.

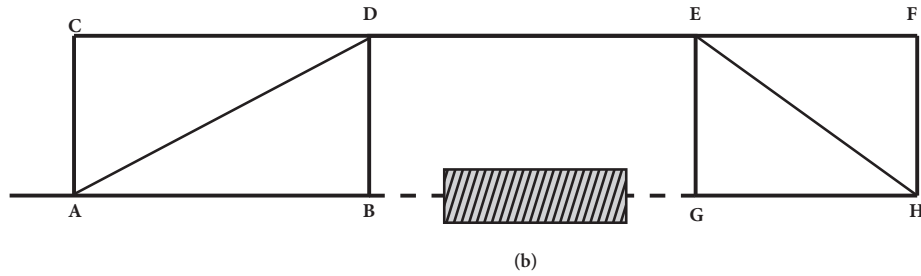

Obstacles to both chaining and ranging

5. Measure DE. That is the obstructed distance between BG. ($DE = BG$)

3.2.7 Errors in chaining

The common types of errors are:

1. Mistakes
2. Compensating errors (or) accidental errors (or) random errors
3. Cumulative errors (or) systematic errors

1. Mistakes

Mistakes occur due to displacement of arrow, miscounting the number of chains, misreading the chain length, erroneous recording, etc.

2. Compensating errors

They are liable to occur in either direction and hence tend to compensate. They do not affect results much.

These errors are caused by the following reasons

- i. Incorrect holding of the chain
- ii. If the fractional part of the chain may not be correct
- iii. Tape is not calibrated uniformly throughout its length.

3. Cumulative errors

These are the errors which are liable to occur in the same direction and tend to accumulate. Cumulative errors occurred due to

1. Bends in links, knots in links, removal of rings during adjustment of chain.

2. Slope correction is not applied when measuring along sloping ground.
3. Sag correction is not applied when chain is suspended in air
4. Measurements are made along the incorrectly aligned line.

3.3 Levelling

3.3.1 Definition

Levelling is the art of determining the relative vertical heights of different points on the surface of earth. Hence, in levelling, the measurements are taken only in the vertical plane.

3.3.2 Basic terms used in levelling

1. Level surface

It is defined as curved surface which is parallel to the mean spheroidal surface of the earth.

2. Level line

It is a line lying in the level surface. All points on the level line are at the same elevation.

3. Horizontal line

It is a straight line lying in the horizontal plane. It is tangential to the level line and perpendicular to the vertical line at that point.

4. Horizontal plane

It is a plane perpendicular to the direction of gravity. It is tangential to the level surface at that point.

5. Vertical line

It is a line indicated by a freely suspended plumb bob. It is a line along the direction of gravity.

6. Vertical plane

It is a plane containing a vertical line at a point.

7. Datum surface

It is any level surface taken as a reference for the determination of elevation of various points. The datum commonly used is Mean Sea Level (MSL).

8. Mean Sea Level (MSL)

It is a level surface which represents the average sea water level.

9. Reduced level

The vertical distance above (or) below the datum is known as elevation. It's level is called reduced level.

3.3.3 Benchmark and its types

Benchmark is defined as a fixed reference point of known elevation. It is denoted by BM

The types of benchmarks are:

1. Great Trigonometrical Survey Benchmark (GTS)
2. Permanent Benchmark
3. Temporary Benchmark
4. Arbitrary Benchmark

3.3.4 Instruments used in leveling

The instruments used in leveling are

- i. Level
- ii. Leveling staff

3.3.5 Different types of levels

The following are the various types of levels

1. Dumpy level
2. Tilting level

3. Quick setting level

4. Wye or Y level

5. Reversible level

6. Automatic level

7. Laser level

3.3.6 Setting up instrument

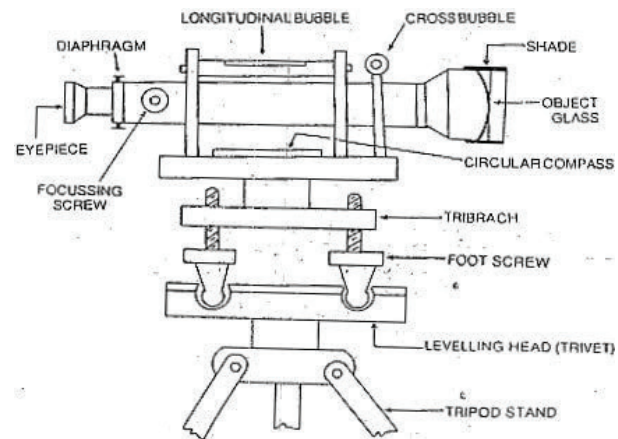

DUMPY LEVEL

(i) Adjusting of a level

The types of adjustments to be done in a level are

1. Temporary adjustment
2. Permanent adjustment

1. Temporary adjustment

The operations involved in temporary adjustments are

- a. Setting up the level
- b. Levelling up
- c. Elimination of parallax

a. Setting up the level

- i. Fixing the instruments on to the tripod.
- ii. Approximately leveling the instrument by leg adjustment.

b. Levelling up

The purpose of leveling up is to make the vertical axis truly vertical.

It is done with the help of three foot screws.

1. The bubble tube is kept parallel to any two foot screws. The foot screws are turned both inwards or outwards until the bubble is central.
2. Now the telescope is rotated to 90° so that it lies over the third foot screw.
3. The third screw is turned until the bubble is central.
4. Now, the telescope is rotated back to its old position. The procedure in steps 1 to 3 is repeated till the bubble remains central in all position.
5. The bubble should remain central if the instrument is in proper adjustment.

c. Elimination of parallax

It is the process of making the image of an object to exactly fall on the plane of crosshairs (diaphragm). Unless parallax is eliminated, accurate sighting is impossible. It consists of focusing the eyepiece and objective of level.

i. Focusing the eyepiece

The operation is done to make the crosshairs to appear distinct and clearly visible. The steps involved in this operation are:

1. The telescope is directed towards sky (or) a sheet of white paper is held in front of the objective.
2. The eyepiece is moved in or out till the crosshairs appear distinct.

ii. Focusing the objective

The operation is done to bring the image of the object in the plane of cross hairs. The steps involved in this operation are.

- i. The telescope is directed towards the staff

- ii. The focusing screw is turned until the image appears clear and sharp.

2. Permanent Adjustment

These are the adjustments which are made to establish fixed relationships between the fundamental parts or fundamental lines of a leveling instrument.

The fundamental lines of a leveling instrument are:

- Axis of bubble tube
- Axis of telescope
- Line of collimation
- Vertical axis

Permanent adjustments once done may keep the instrument in perfect condition for a long time.

Activity 2

Prepare a report about different types of levelling instruments.

3.3.7 Levelling staff

Levelling staff is a graduated rod of rectangular cross section. It is used for the measurement of vertical distance between the line of sight and the point on which the staff is held. It is also known as level rod.

The levelling staff is usually made of best quality seasoned teak wood or aluminium channel. The length of levelling staff in common use are 2 m, 3 m, 4 m and 5 m.

Graduations of the staff give the distances from the bottom of the cap. Each meter is divided into 20 divisions. The thickness of each division is 5 mm.

(i) Types of levelling staff

Based on the method of taking reading, the levelling staffs are divided into two types

1. Self reading staff (or) direct reading staff
2. Target staff

1. Self reading staff

In this type of staff the observer takes the reading directly on the staff by looking through the telescope.



Self reading staff

Based on the method of construction self reading staffs are further divided into 4 types.

- Solid staff
- Folding staff
- Telescopic staff
- Invar precession staff

2. Target staff

In this type of staff the observer sights the target and directs the staffman to move the target upward (or) downward until it bisects the line of sight exactly.



Target levelling staff

3.3.8 Reduction of Levels

Reduction of level means reducing the elevation of a point from the observed staff reading. It can be done by two methods

- a. Height of collimation method
- b. Rise and fall method

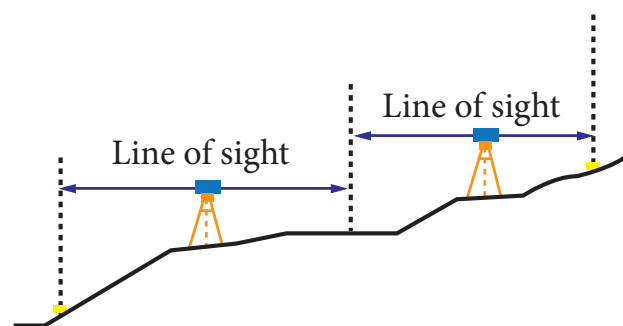
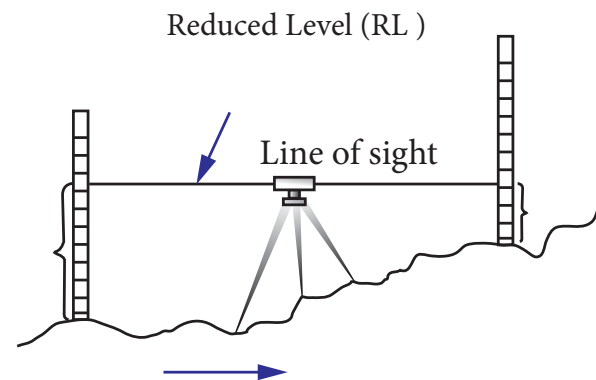

a. Height of collimation method**Procedure:**

1. In this method, height of collimation (HC) is calculated for each setting of instrument

Height of collimation (HC) = RL of BM + Back sight

2. The reduced levels of intermediate points (IS) and foresight sight points (FS) are calculated by using the formula.

RL = HC - IS (or)

HC - FS

3. When the instrument is shifted to a new position (C.P), a new height of collimation level is setup and the steps (1) and (2) are repeated

Note:

HC = Height of collimation level

BS = Back sight reading

IS = Intermediate sight reading

FS = Foresight reading

RL = Reduced Level

BM = Bench mark

C.P = Change Point

b. Rise and fall method**Procedure:**

1. In this method the difference of level between consecutive points is found by comparing staff readings
Rise indicates (+) and fall indicates (-).

i.e., BS - IS (Or) IS - IS (or)

I.S - F.S

2. RL of any point = (RL of preceding point) + Rise (or) - fall

**Digital Level**

- They are not popular instead auto levels are more extensively used.
- The Trimble DiNi Digital level: Determine accurate height information 60% faster than with automatic levelling.
- Eliminate errors and reduce rework with digital readings.
- Transfer data to the office easily.
- Measure to a field of just 30 cm.



Example 1:

The page of a level book is given below. Calculate the RL of all the points by any one of the methods. Apply usual checks. Assume the RL of BM as 25.000m.

| Station | BS | IS | FS | Remarks |
|---------|-------|-------|-------|---------|
| A | 1.120 | | | BM |
| B | | 1.650 | | |
| C | | 1.750 | | |
| D | 1.200 | | 2.900 | CP1 |
| E | | 1.660 | | |
| F | | 2.520 | | |
| G | 0.900 | | 3.250 | CP2 |
| H | 1560 | | 2.100 | |
| I | | | 2.200 | |

Solution**Type (I) Height of collimation method**

The observation are tabulated and reduced levels are obtained as follows.

| Station | BS | IS | FS | HC or HI | RL | Remarks |
|---------|-------|-------|--------|----------|--------|---------|
| A | 1.120 | | | 26.120 | 25.000 | BM |
| B | | 1.650 | | | 24.470 | |
| C | | 1.750 | | | 24.370 | |
| D | 1.200 | | 2.900 | 24.420 | 23.220 | CP1 |
| E | | 1.660 | | | 22.760 | |
| F | | 2.520 | | | 21.900 | |
| G | 0.900 | | 3.250 | 22.070 | 21.170 | CP2 |
| H | 1.560 | | 2.100 | 21.530 | 19.970 | |
| I | | | 2.200 | | 19.330 | |
| Total | 4.780 | | 10.450 | | | |

Calculations

$$\text{HC for I set up} = \text{RL of A} + \text{BS of A} = 25.000 + 1.120 = 26.120$$

$$\text{RL of B} = \text{HC for I set up} - \text{IS of B} = 26.120 - 1.650 = 24.470$$

$$\text{RL of C} = \text{HC for I set up} - \text{IS of C} = 26.120 - 1.750 = 24.370$$

$$\text{RL of D} = \text{HC for I set up} - \text{IS of D} = 26.120 - 2.900 = 23.220$$

$$\text{HC for II set up} = \text{RL of D} + \text{BS of D} = 23.220 + 1.200 = 24.420$$

$$\text{RL of E} = \text{HC for II set up} - \text{IS of E} = 24.420 - 1.660 = 22.760$$

$$\text{RL of F} = \text{HC for II set up} - \text{IS of F} = 24.420 - 2.520 = 21.900$$

$$\text{RL of G} = \text{HC for II set up} - \text{IS of G} = 24.420 - 3.250 = 21.170$$

HC for III set up = RL of G + BS of G = 21.170 + 0.900 = 22.070

RL of H = HC for III set up - IS of H = 22.070 - 2.100 = 19.970

HC for IV set up = RL of H + BS of H = 19.970 + 1.560 = 21.530

RL of I = HC for IV set up - IS of I = 21.530 - 2.200 = 19.330

Arithmetic check

Σ BS ~ Σ FS = first RL ~ last RL

4.780 ~ 10.450 = 25.000 ~ 19.330

5.670 = 5.670

Hence checked

Type (II) Rise and fall method

| Station | BS | IS | FS | Rise (+) | Fall (-) | RL | Remarks |
|---------|-------|-------|--------|----------|----------|--------|---------|
| A | 1.120 | | | | | 25.000 | BM |
| B | | 1.650 | | | 0.530 | 24.470 | |
| C | | 1.750 | | | 0.100 | 24.370 | |
| D | 1.200 | | 2.900 | | 1.150 | 23.220 | CP1 |
| E | | 1.660 | | | 0.460 | 22.760 | |
| F | | 2.520 | | | 0.860 | 21.900 | |
| G | 0.900 | | 3.250 | | 0.730 | 21.170 | CP2 |
| H | 1.560 | | 2.100 | | 1.200 | 19.970 | |
| I | | | 2.200 | | 0.640 | 19.330 | |
| Total | 4.780 | | 10.450 | | 5.670 | | |

Calculation

- Level difference between points A and B = 1.120 - 1.650 = -0.530
- Level difference between points B and C = 1.650 - 1.750 = -0.100
- Level difference between points C and D = 1.750 - 2.900 = -0.150
- Level difference between points D and E = 1.200 - 1.660 = -0.460
- Level difference between points E and F = 1.660 - 2.520 = -0.860
- Level difference between points F and G = 2.520 - 3.250 = -0.730
- Level difference between points G and H = 0.900 - 2.100 = -1.200
- Level difference between points H and I = 1.560 - 2.200 = -0.640

Arithmetic check

Σ BS ~ Σ FS = Σ Rise ~ Σ Fall = first RL ~ last RL

4.780 ~ 10.450 = 0 ~ 5.670 = 25.000 ~ 19.330

5.670 = 5.670 = 5.670

Hence checked

Example 2:

The following staff readings were observed successively with a level. The instrument having been moved after the second, fifth and eighth readings.

0.675, 1.230, 0.750, 2.565, 2.225, 1.935, 1.835, 3.220, 3.115 and 2.875. The RL of BM is 100.000 m

Obtain the reduced levels of each point and apply usual check.

Brief explanation for tabulating the readings.

1. The readings are tabulated in their respective method of tabulation.
2. In every setting up of instrument the first reading taken as BS. Last reading taken as FS, and other between readings as IS
3. The instrument is shifted (or) moved after the 2nd , 5th , 8th readings. They are the F. S readings.
4. Therefore 1,3,6,9 are BS readings and the others are IS reading (4,7)
5. Final reading is a FS reading. (10)
6. In two settings with a change point, first set's last reading being FS and second set's first reading being BS. They are entered in a same line for continuity of leveling process.

Solution**(i) Height of collimation method**

| Station | BS | IS | FS | HC or HI | RL | Remarks |
|---------|-------|-------|-------|----------|---------|-----------------|
| A | 0.675 | | | 100.675 | 100.000 | BM |
| B | 0.750 | | 1.230 | 100.195 | 99.445 | CP ₁ |
| C | | 2.565 | | | 97.630 | |
| D | 1.935 | | 2.225 | 99.905 | 97.970 | CP ₂ |
| E | | 1.835 | | | 98.070 | |
| F | 3.115 | | 3.220 | 99.880 | 96.685 | CP ₃ |
| G | | | 2.875 | | 96.925 | |
| Total | 6.475 | | 9.550 | | | |

Calculations:

$$\text{HC for I set up} = \text{RL of A} + \text{BS of A} = 100.000 + 0.675 = 100.675$$

$$\text{RL of B} = \text{HC for I set up} - \text{FS of B} = 99.445$$

$$\text{HC for II set up} = \text{RL of B} + \text{BS of B} = 100.195$$

$$\text{RL of C} = \text{HC for II set up} - \text{FS of C} = 97.630$$

$$\text{RL of D} = \text{HC for II set up} - \text{FS of D} = 97.970$$

$$\text{HC for III set up} = \text{RL of D} + \text{BS of D} = 99.905$$

$$\text{RL of E} = \text{HC for III set up} - \text{FS of E} = 98.070$$

$$\text{RL of F} = \text{HC for III set up} - \text{FS of F} = 96.685$$

$$\text{HC for IV set up} = \text{RL of F} + \text{BS of F} = 99.880$$

$$\text{RL of G} = \text{HC for IV set up} - \text{FS of G} = 96.925$$

Arithmetic check

$$\Sigma BS \sim \Sigma FS = \text{first RL} \sim \text{last RL}$$

$$6.475 \sim 9.550 = 100.000 \sim 96.925$$

$$3.075 = 3.075$$

Hence checked**(II) Rise and fall method**

| Station | BS | IS | FS | Rise (+) | Fall (-) | RL | Remarks |
|---------|-------|-------|-------|----------|----------|---------|-----------------|
| A | 0.675 | | | | | 100.000 | BM |
| B | 0.750 | | 1.230 | | 0.555 | 99.445 | CP ₁ |
| C | | 2.565 | | | 1.815 | 97.630 | |
| D | 1.935 | | 2.225 | 0.340 | | 97.970 | CP ₂ |
| E | | 1.835 | | 0.100 | | 98.070 | |
| F | 3.115 | | 3.220 | | 1.385 | 96.685 | CP ₃ |
| G | | | 2.875 | 0.240 | | 96.925 | |
| Total | 6.475 | | 9.550 | 0.680 | 3.755 | | |

Calculation**Level difference of station**

$$\text{Level difference between the stations A and B} = 0.675 - 1.230 = - 0.555$$

$$\text{Level difference between the stations B and C} = 0.750 - 2.565 = - 1.815$$

$$\text{Level difference between the stations C and D} = 2.565 - 2.225 = - 1.960$$

$$\text{Level difference between the stations D and E} = 1.935 - 1.835 = + 0.100$$

$$\text{Level difference between the stations E and F} = 1.835 - 3.220 = - 1.285$$

$$\text{Level difference between the stations F and G} = 3.115 - 2.875 = + 0.240$$

RL of station

$$\text{RL of B} = \text{RL of A} \pm \text{level difference of B} = 100.00 - 0.555 = 99.445$$

$$\text{RL of C} = \text{RL of B} \pm \text{level difference of C} = 99.445 - 1.815 = 97.630$$

$$\text{RL of D} = \text{RL of C} \pm \text{level difference of D} = 97.630 + 0.340 = 97.970$$

$$\text{RL of E} = \text{RL of D} \pm \text{level difference of E} = 97.970 + 0.100 = 98.070$$

$$\text{RL of F} = \text{RL of E} \pm \text{level difference of F} = 98.070 - 1.385 = 96.685$$

$$\text{RL of G} = \text{RL of F} \pm \text{level difference of G} = 96.685 + 0.240 = 96.925$$

Arithmetic check

$$\Sigma BS \sim \Sigma FS = \Sigma \text{Rise} \sim \Sigma \text{fall} = \text{first RL} \sim \text{last RL}$$

$$6.475 \sim 9.550 = 0.680 \sim 3.755 = 100.000 \sim 96.925$$

$$3.075 = 3.075 = 3.075$$

Hence checked

Example 3:

Record the observations in the form of levelling field book and obtain reduced level of each point. Apply usual check.

Reading of inverted staff on a point 'A' whose reduced level 15.995 m is 3.220. Reading of staff on a point 'B' on ground is 0.805. Change the instrument and the reading of staff on point 'B' is again 1.280. Inverted Reading of staff on point C is 3.695.

Type I: Height of Collimation method**Solution:**

The observation are tabulated and reduced levels are calculated as follows.

| Station | BS | IS | FS | HC | RL | Remarks |
|---------|--------|----|--------|--------|--------|---------|
| A | -3.220 | | | 12.775 | 15.995 | BM - 1 |
| B | 1.280 | | 0.805 | 13.250 | 11.970 | CP |
| C | | | -3.695 | | 16.945 | BM - 2 |
| Total | -1.940 | | -2.890 | | | |

(Negative sign indicates inverted staff reading)

Calculations

$$\text{HC for I set up} = \text{RL of A} + \text{BS of A} = 15.995 + (-3.220) = 12.775$$

$$\text{RL of B} = \text{HC for I set up} - \text{FS of B} = 12.775 - 0.805 = 11.970$$

$$\text{HC for II set up} = \text{RL of B} + \text{BS of B} = 11.970 - 1.280 = 13.250$$

$$\text{RL of C} = \text{HC for II set up} - \text{FS of C} = 13.250 - (-3.695) = 16.945$$

Arithmetic check

$$\Sigma \text{BS} \sim \Sigma \text{FS} = \text{first RL} \sim \text{last RL}$$

$$1.940 \sim 2.890 = 16.945 \sim 15.995$$

$$0.950 = 0.950$$

Hence checked

Type II Rise and fall method

| Station | BS | IS | FS | Rise (+) | Fall (-) | RL | RL |
|---------|--------|----|--------|----------|----------|--------|--------|
| A | -3.220 | | | | | 15.995 | BM - 1 |
| B | 1.280 | | 0.805 | | 4.025 | 11.970 | CP |
| C | | | -3.695 | 4.975 | | 16.945 | BM - 2 |
| Total | -1.940 | | -2.890 | 4.975 | 4.025 | | |

(Negative sign indicates inverted staff reading)

Calculations

Level difference between the stations A and B = $-3.220 - 0.805 = -4.025$

Level difference between the stations B and C = $1.280 - (-3.695) = 4.975$

Arithmetic check

$\Sigma BS \sim \Sigma FS = \Sigma Rise \sim \Sigma fall = \text{first RL} \sim \text{last RL}$

$1.940 \sim 2.890 = 4.975 \sim 4.025 = 16.945 \sim 15.995$

$0.950 = 0.950 = 0.950$

Hence checked

Problems to solve

- The following is the page of field book. Complete the RL of all the points by any one method. Apply usual check.

| Station | BS | IS | FS | RL | Remarks |
|---------|-------|-------|-------|---------|-----------------|
| 1 | 0.250 | | | 105.750 | BM |
| 2 | | 0.465 | | | |
| 3 | 1.750 | | 0.765 | | CP ₁ |
| 4 | | 1.985 | | | |
| 5 | | 2.530 | | | |
| 6 | | 1.980 | | | |
| 7 | 0.680 | | 0.865 | | CP ₂ |
| 8 | | | 2.535 | | |

- Complete in all respects the following page of a field book and apply usual check. Determine the RL of all points by any one method.

| Station | BS | IS | FS | RL | Remarks |
|---------|-------|-------|-------|---------|-----------------|
| 1 | 3.920 | | | 116.750 | BM |
| 2 | 1.460 | | 7.780 | | CP ₁ |
| 3 | 7.050 | | 3.270 | | CP ₂ |
| 4 | | 2.360 | | | |
| 5 | 4.810 | | 0.850 | | CP ₃ |
| 6 | 8.630 | | 2.970 | | CP ₄ |
| 7 | 7.020 | | 3.910 | | CP ₅ |
| 8 | | | 4.280 | | |

3. The following staff readings were observed successively with a level 0.875, 1.235, 2.310, 1.385, 2.930, 3.125, 4.125, 0.120, 1.875, 2.030 m.

The first reading taken on BM is 132.135 m. The instrument has been moved after 2nd, 5th and 8th reading. Enter the readings in a field book form and reduce the RLs. Apply usual checks.



3.4 Advancements in Surveying

3.4.1 Introduction

With advancements in technology, new surveying equipments and techniques are developing. Current advancements are making the science of surveying more valuable, accurate and comprehensive than ever.

Few advancements in surveying instruments are discussed below

- Total station
- Global Positioning system
- Geographical Information system

3.4.2 Total Station (TS)

It is used for surveying and building construction. It is an electronic transit instrument integrated with electronic distance measurement (EDM) to measure both vertical and horizontal distance and the slope distance from the instrument to a particular point.

Robotic total stations allow the operator to control the instrument from a distance via remote control. This eliminates the need of an assistant staff member as the operator holds the retro-reflector and control the total station from observed point.



Total Station

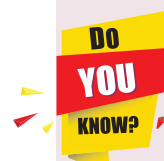

Drone survey

Drone surveys are a faster, safer and more cost-efficient way to survey at height. Sometimes referred to as aerial surveys; UAS (Unmanned Aerial System) surveys, or UAV (Unmanned Aerial Vehicle) surveys, drone surveys are more popular method of surveying.

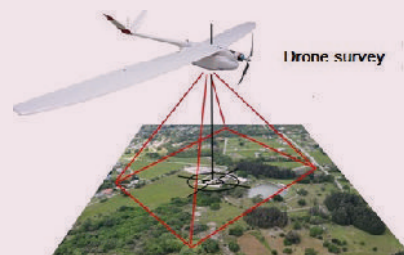



Activity 3

Differentiate total station from other levelling instruments and submit a report.

3.4.3 Global Positioning System (GPS)

The Global Positioning System (GPS) is a satellite based navigation

and surveying system. It is adopted for the determination of precise position and time using radio signals from satellites.

GPS is a U.S space based radio navigation system freely available to all civilian user in all weather conditions, day and night anywhere in the world.

Now a days, GPS is finding its way into cars, boats, planes, construction equipments, farm machinery, cell phones and even in laptop computers.

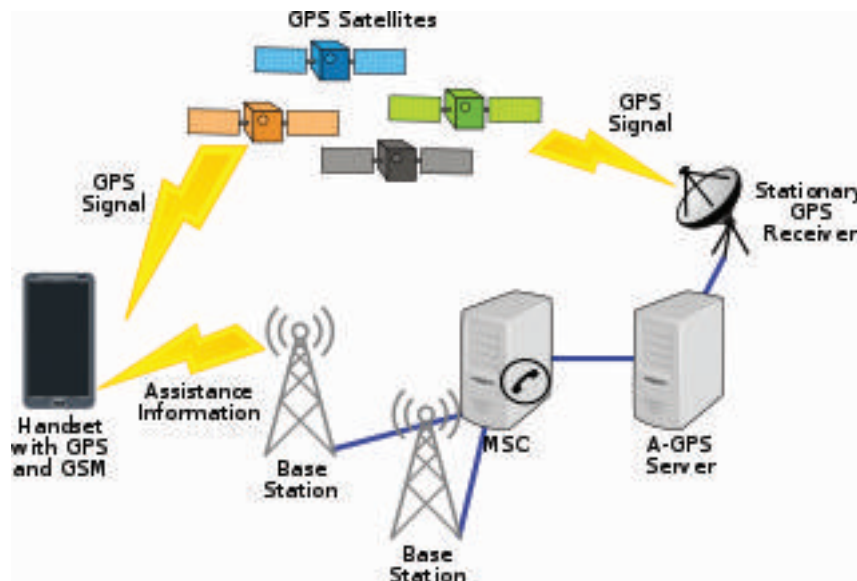
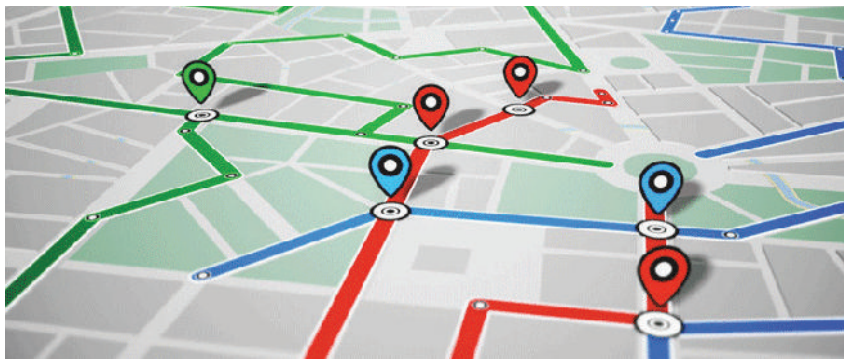

Fundamentals of GPS

GPS basically comprised of 3 segments

1. **Control segment:** Control segment consist of one master control station located at Colorado (USA) and five monitor stations located throughout the world.
2. **Space segment:** It consist of group of 24 satellites in 6 orbital planes. 4 satellites in each plane 20.200 km altitude and 55° inclination.
3. **User segment:** It consist of antennas, receiver, processor, display and a regulated DC power supply.

The GPS provides full coverage with minimum of 4 satellites at any place all over the globe. These 4 GPS satellite broadcast signals simultaneously from the space that are picked up and identified by GPS receivers. Each GPS receiver then provides three dimensional location (latitude, longitude and altitude) plus time.

Uses of GPS

- a. **Location** – Determining a basic position
- b. **Navigation** – Getting from one location to another
- c. **Tracking** – Monitoring the movement of people and things
- d. **Mapping** – Creating maps
- e. **Timing** – Provides precise timing

Application of GPS

- 1. Land applications
- 2. Air applications
- 3. Marine applications

- 4. Space applications
- 5. Military applications

3.4.4 Geographic Information system (GIS)

GIS is a system designed to capture, store, manipulate, analyze, manage and present geographic data.

GIS applications are tools that allow users to analyze geographical information, edit data in maps, and present the results of all these operation.



GIS updates geographical data without wasting time to visit the field and update a database manually.

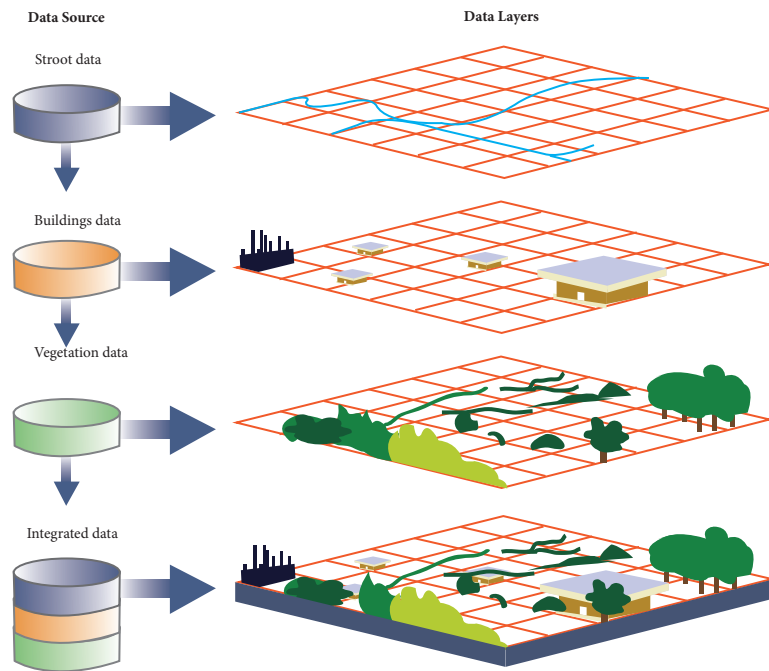

Geographical Information System



MODEL QUESTIONS



Part - I

Choose the correct answer (1 Mark)

- The determination of the relative positions of the object on the surface by making linear and angular measurement is called _____.
 - Measurement
 - Surveying
 - Traversing
 - Levelling
- The primary object of surveying is to prepare _____.
 - data
 - Longitudinal section
 - Map
 - Cross section
- The geodetic surveying is called _____.
 - Plane surveying
 - Trigonometrical surveying
 - Mine surveying
 - Military surveying
- The process of measuring distances with a chain is called _____.
 - Levelling survey
 - chain survey
 - compass survey
 - plane table survey
- The distance between the centers of the two consecutive middle links of a metric chain is called _____.
 - length of link
 - length of chain
 - distance of link
 - distance of chain

- The abbreviation of GPS is _____.
 - Global positioning system
 - Guide positioning system
 - Global precise system
 - Global positioning section
- The user receiving equipment in a GPS system is called _____.
 - GPS receiver
 - control segment
 - space segment
 - user segment

Part – II

Answer in one or two sentences (3 Marks)

- Define surveying.
- What do you mean by chaining?
- Define levelling.
- Define Mean sea level.
- Differentiate between level surface and horizontal surface.
- State the fundamentals of GPS.

Part – III

Answer in brief (5 Marks)

- Differentiate between geodetic surveying and plane surveying.
- Describe the different types obstacle in chain surveying.
- What is a bench mark? List the different types of benchmark.
- Briefly discuss about total station.



Part –IV

Answer in detail (10 Marks)

1. State the main divisions and general classification of surveying.
2. What do you mean by ranging? Explain the types of ranging.
3. Explain with a neat diagram the construction and working of an optical square.
4. Explain the temporary adjustments of a dumpy level.
5. The level readings taken are listed as follows:
1.430, 2.015, 1.005, 0.400, 3.370, 2.975, 1.415, 0.695

The instrument is shifted after the 4th and 8th readings. The RL of 1st point is 100.000 m. Enter the reading in a field book form and reduce the RL by HC Method. Apply usual check.

6. The level readings taken are listed below:
4.390, 7.620, 6.520, 3.910, 5.390, 4.730, 6.290, 3.520, 4.330, 2.990.

The RL of First point is 200.000 m. The instrument is shifted after 3rd and 8th points. Enter the reading in a field book form and reduce RL by Rise and fall method. Apply usual check.

Answers:
1) b 2) c 3) b 4) b 5) a 6) a 7) a



UNIT 4

**WATER SUPPLY
ENGINEERING**



“ Water is life, and clean water means health. ”

Audrey Hepburn



Table of Contents

| | |
|--|---|
| 4.1 Introduction | 4.4.2 Screening |
| 4.1.1 Objectives of Public Water Supply Schemes | 4.4.3 Sedimentation |
| 4.1.2 Planning of Water Supply Scheme | 4.4.4 Filtration |
| 4.1.3 Water Demands | 4.5 Disinfection of Water |
| 4.1.4 Per Capita Demand | 4.5.1 Necessity of Disinfection |
| 4.2 Sources of Water | 4.5.2 Methods of Disinfection |
| 4.2.1 Surface sources | 4.6 Water Softening |
| 4.2.2 Sub surface sources | 4.6.1 Purpose of water softening |
| 4.3 Quality of Water | 4.6.2 Hardness of Water |
| 4.3.1 Impurities in water and its classification | 4.7 Distribution System of Water |
| 4.3.2 Test on Water | 4.7.1 Methods of distribution |
| 4.4 Treatment of Water | 4.7.2 Systems of water supply |
| 4.4.1 Functions and locations of Treatment Units | 4.7.3 Methods of Layout of Distribution pipes |

Learning Objectives

At the end of this lesson you shall be able to

- Understand the objectives and planning of water supply schemes
- Know the various sources of water
- Understand the quality of water
- Explain the different stages of treatment of water
- Understand the necessity of disinfection of water
- State the purpose of water softening
- Explain the distribution system of water

4.1 Introduction

The essential elements for the existence of human beings are air, water, food, shelter, clothing, etc. Out of the above, water is the second element. Water is required for the satisfactory physiological functioning of living organisms, as a circulatory fluid to maintain temperature, to carry nourishing food and to remove the waste products from the body.

It is necessary that, water must be good and it should be free from impurities, toxic chemical compounds and pathogens. Therefore, in order to ensure the availability of sufficient quantity of good quality of water, it is essential to plan and build suitable water supply schemes.

4.1.1 Objectives of Public Water Supply Schemes

Following are the objectives of public water supply scheme:

1. To supply safe, wholesome water to the people so as to keep the diseases away and thereby promoting better health.
2. To maintain better sanitation and beautification of surroundings.
3. To ensure safety against fire, by supplying sufficient quantity of water.
4. To provide industrialisation and modernisation of the society and thereby ensuring better living standards.
5. To promote wealth and welfare for the entire community.

4.1.2 Planning of Water Supply Scheme

The water supply scheme for a city is prepared by the combination of field observation and office work. Following

are the points of importance in any water supply scheme.

1. Population

From the available data of census of the last two decades, the future population may be predicted by any suitable method. Based on the future expansion, the water requirement for the scheme is decided.

2. Per Capita water demand

The rate of consumption of water per capita should be decided by taking all the possible uses of water as domestic, industrial, public, trade, fire demand, etc. The rate when multiplied by the population gives total quantity of water required for water supply schemes.

3. Sources of Water supply

The success of a water supply scheme entirely depends upon a good source of supply of water. The source should provide adequate and good quality of water throughout the year.

4. Quality of water

The quality of available water decides the line of treatment of water. The cost of treatment depends on its quality. If the water is pure, lesser will be the cost of treatment

5. Financial aspects

Based on the fund availability, the scheme should be adjusted and it should be as economical as possible.

6. Topography of the area

The topographical map of the area should be prepared. Low lying area, plain area, ridges, high density of population area should be marked on the map and analysed to ensure a simple and cheap water supply scheme.

Flow Chart of a Water Supply Scheme

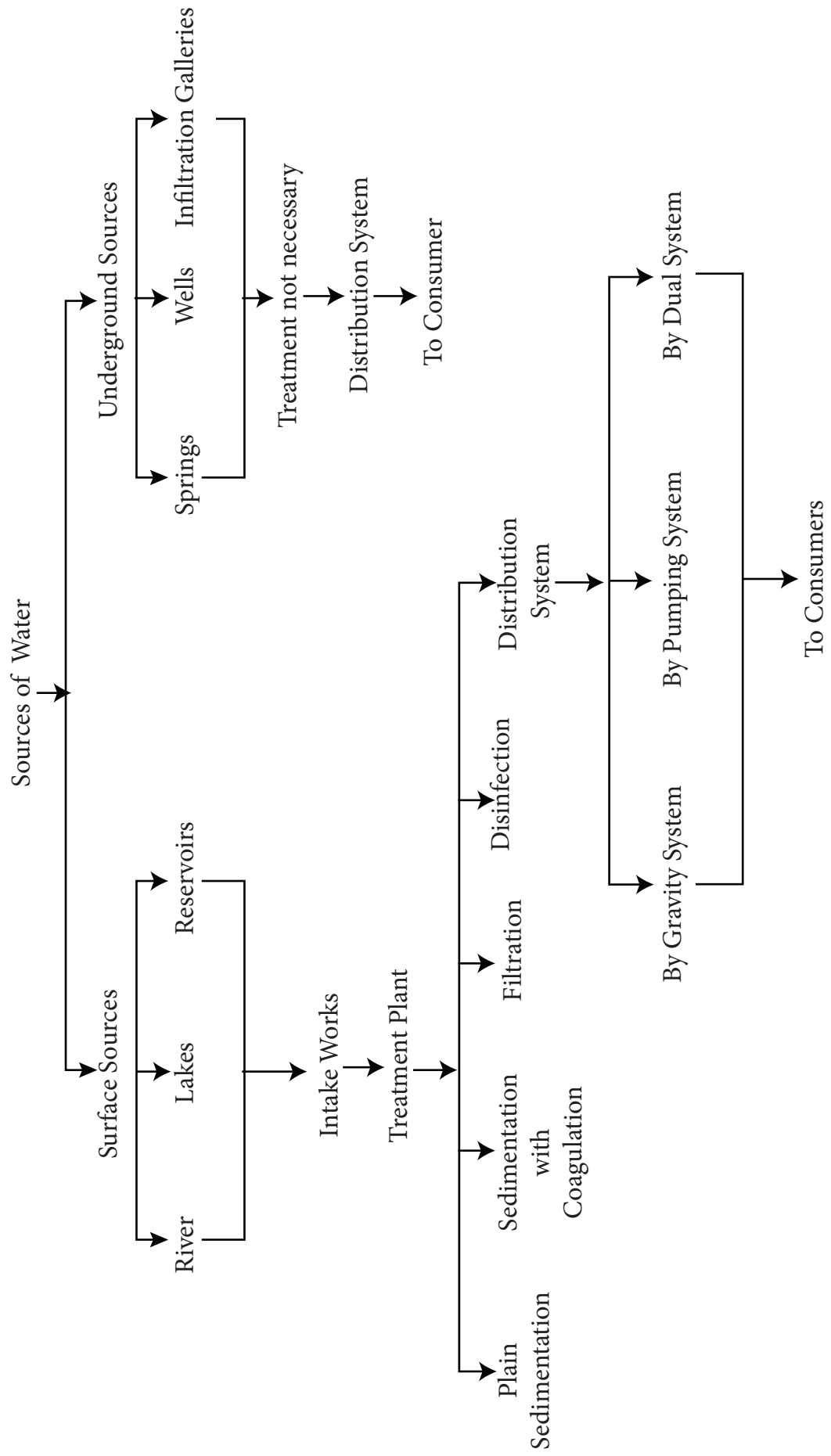

7. Development of the town

The trends of the future development of the town or city should be predicted and properly adjusted while planning the water supply scheme.

4.1.3 Water Demands

The first step in the design of a water supply project is the determination of water demand. This includes the quantity of water that will be required for various purposes with the provision for the estimated requirements of future. Next a reliable source of water must be located.

Following are the various types of demand,

1. Domestic demand
2. Industrial and commercial demand
3. Public demand
4. Fire demand
5. Loss and waste

1. Domestic demand

The domestic demand includes the water required in the houses for drinking, cooking, bathing, washing, sanitary purposes, private uses, gardening, etc. In Indian towns or cities, the domestic consumption of water under normal condition is 135 litres/day/capita as per IS: 1172-1993. This amount is about 50% of total consumption.

2. Industrial and Commercial Demand

This includes water required for hotels, factories, business centres, dairy, sugar refineries, stores, offices, etc. The Consumption will vary greatly with the character of the city. This amounts to 20-25% of the total consumption.

3. Public Demand

This includes water required for flushing sewers, sprinkling streets, fountains, ornamental displays, swimming pools, public buildings, temples etc. This amounts to about 10% of the total consumption.

4. Fire Demand

It is the quantity of water required for fire fighting purposes. In India, the quantity of water required for fire prevention is taken as 1lit/capita/day. This amounts to 5 to 10% of total consumption.

5. Loss and waste

This includes the water loss in pipe line due to various reasons like defective pipe joints, cracks, thefts, faulty valves and fittings. This amounts to about 15% of total consumption.

4.1.4 Per Capita Demand

It is the annual average amount of daily water required by one person and includes the domestic use, Industrial and commercial use, public use, wastes, thefts etc. It may therefore be expressed as

$$\text{Per capita demand} = Q/(P \times 365) \text{ lits/day}$$

Where Q = Total Quantity of water required by a town per year in litres

P = population

Factors affecting the per capita Demand

The following factors affect the per capita demand

1. Climatic conditions
2. Cost of water
3. Distribution pressure
4. Habits of people
5. Industries and commerce

6. Metering
7. Quality of water
8. Sewerage system
9. Size of community
10. System of supply
11. Age of community
12. Lawn sprinkling
13. Fire demand

1. Climatic conditions

Hotter climates need more water due to more bathing, air conditioning and more lawn and street sprinkling.

2. Cost of water

More the cost of water, lesser will be the amount of consumption of water.

3. Distribution pressure

The Consumption of water increases with increase in distribution pressure due to heavy losses and wastes.

4. Habits of people

People of higher economic status and better standard of living require more water supply.

5. Industries and commerce

Water consumption is usually more when water is to cater for large industrial and commercial uses.

6. Metering

Use of water decreases when the supplies are metered.

7. Quality of water

Safe and wholesome water will always result in an increased consumption.

8. Sewerage system

The existence of sewerage system in a locality will lead to an increase in

use of water for flushing of sanitary appliances.

9. Size of community

In a large city, the water demand per head may be more as lot of water is used for maintaining clean and healthy environments.

10. System of water supply

Generally Intermittent supply of water will reduce the rate of demand.

11. Age of community

Older and more stable communities use less amount of water than rapidly developing communities where new homes are being constructed and owners are planting new lawns.

12. Lawn Sprinkling

Enforcement of lawn sprinkling regulations can reduce peak demands significantly.

13. Fire demand

The frequency of occurrence of fire and its size, largely contribute to the demands considerably.

4.2 Sources of Water

The source of water is selected such that it may be able to fulfil all the demands. The following points should be considered while selecting the sources of water for a water supply scheme.

1. Location

The source should be as near as possible to the town or city to minimise the cost of conveyance.

2. Elevation of Intake point

The reduced level (R. L) of the point should be higher than that of the supply

Famous hot springs in India



Some of the famous hot springs of Himachal Pradesh are:

- **Manikaran Hot Springs.** Located in Parvati of Kullu District, Manikaran is known for sulphur **hotwater springs.** ...
- **Kheerganga Hot Springs.**
- **Tattapani Hot Springs.**
- **Vashisht Hot Springs**



zone so that the water can flow by gravity. Otherwise, pumping unit will increase the cost of the scheme.

The source should be such that the required quantity of water may be available throughout the year to meet the water demand.

3. Quantity of water

Sources of water



Arabian Sea, Kerala



Ganges River in India



Chillika Lake in India



All Indian Village Pond

4. Quality of water

The cost of the treatment depends on the quality of water. Bad quality water requires excessive treatment and increases the cost. But the good quality requires less treatment and decreases the cost of the scheme.

The sources from which water is obtained for water supply can be classified into two types

1. Surface sources
2. Sub surface sources

4.2.1 Surface sources

The primary source of water is rain. When rain falls on the ground, a certain portion percolates into the ground and the balance portion remains on the ground as surface water. The usual forms of surface sources are as follows:

- i. Ponds
- ii. Lakes and streams
- iii. Storage reservoirs
- iv. Rivers
- v. Sea

4.2.2 Sub surface sources

These sources obtain their supply from percolation of precipitation. It is comparatively safer, free from suspended impurities and are reliable. It is due to the fact that water get strained during their passage through the porous underground strata. This water contains more dissolved mineral and gases. The bacterial content is usually low. In General, sub surface source water is good in quality. But they may require some treatment to improve their chemical characteristics.

The usual forms of subsurface sources are as follows:

- i. Springs
- ii. Wells
- iii. Infiltration galleries
- iv. Infiltration wells



Well



Activity 1

Identify the sources of water in your school and home. Brief two points of each.

4.3 Quality of Water

The water required for water supplies should be pure. It should be free from pathogens, toxic chemicals, etc., in order to provide good quality. The water should be pre-treated before distribution to the consumers.

Wholesome water

Water which does not contain harmful impurities and which are good or harmless to health is termed as wholesome water. It is bacteriologically pure but chemically not pure.

Distilled water

Distilled water is safe water as it is bacteriologically and chemically pure. But it is unpleasant to drink.



World largest Lake

Wular Lake, located in the state of Jammu and Kashmir, is often referred to as the largest **freshwater lake** in India. Wular is a natural lake that is a major part of the Jhelum River basin.

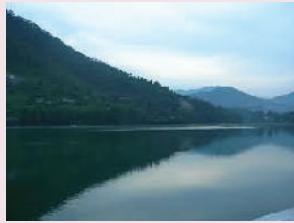

The **Sambhar Salt Lake**, **India's largest inland salt lake**, is located 96 km southwest of the city of Jaipur (Northwest **India**) and 64 km northeast of Ajmer along National Highway 8 in Rajasthan. It surrounds the historical **Sambhar Lake Town**.



4.3.1 Impurities in water and its classification

Impurities in water may be classified as below

- a. Physical Impurities
- b. Chemical Impurities
- c. Bacteriological Impurities

a. Physical Impurities

They are due to the presence of inorganic substances like clay, pebbles, sand, silt, algae, fungi, bacteria, etc., in water in finely divided condition. Physical impurities give taste, odour, colour and turbidity to water.

b. Chemical Impurities

They may be either organic or inorganic and is present in either suspended or dissolved form. The suspended organic chemical impurities are due to the presence of vegetables or animals in water. The dissolved inorganic chemical impurities are caused by the melting of minerals and gases in water.

c. Bacteriological Impurities

The Bacteriological Impurities are caused in water by the presence of bacteria. The bacteria may be harmful or harmless. Harmless bacteria are called non-pathogens. Pathogens are dangerous and are mainly responsible for water borne diseases.

4.3.2 Test on Water

The Analysis of water is carried out in order to establish its quality. Following

| Tests | Properties/ Impurities |
|--------------------------|--|
| 1. Physical tests | <ol style="list-style-type: none"> i. Turbidity ii. Colour iii. Taste iv. Odour |
| 2. Chemical tests | <ol style="list-style-type: none"> i. Total solids ii. Hardness iii. PH value iv. Chloride v. Residual chlorine vi. Iron and Manganese |
| 3. Bacteriological tests | <ol style="list-style-type: none"> i. Total count test ii. E-coli test |

tests are carried out to determine the physical, chemical and bacteriological impurities present in water.

1. Physical tests
2. Chemical tests
3. Bacteriological tests

The list of tests and properties/Impurities determined in the test are tabulated below:

1. Physical Tests

i. Turbidity

Turbidity is caused by the presence of finely divided, suspended and colloidal matters like clay, loam and sand or micro-organisms. It is more during floods. It is a measure of its resistance to the passage of light through it. It is expressed in parts per million (ppm) or milligram per litre (mg/l). The standard unit of turbidity is the turbidity produced by one part of finely divided silica (Fuller's earth) in a million parts of distilled water. For drinking water, the permissible turbidity is 5 to 10 ppm. It is measured by Jackson Turbidimeter.

ii. Colour

Dissolved organic matter from decaying vegetation or some inorganic materials such as coloured soils, etc., may impart colour to the water. The test for true colour should be taken up only removing all the suspended particles by centrifuging. The sample is then compared for colour with standard colour solutions or colour discs.

The unit of colour is the colour produced by one milligram of platinum cobalt in a litre of distilled water. The colour of public water supply should not exceed 20 mg/s. The colour is measured by Tintometer.

iii. Taste and Odour

The dissolved organic materials or the inorganic salts or the dissolved gases

may impart tastes and odours to the water. Taste and odour are generally combined together. Tastes may be sweet, bitter, salty brackish and irritating. Odours may be fishy, earthy, grassy, mouldy, vegetable, etc. The odour is identified by using osmoscope.

2. Chemical Tests

i. Total solids

The total solids consist of dissolved and suspended solids. The total solids present in water can be determined by evaporating a sample of water and weighing the dry residue left. The suspended solids can be found by filtering water sample and weighing the residue left on the filter paper. The difference between the total solids and suspended solids will give the dissolved solids. The amount of total solids should preferably be less than 500 ppm and should never exceed 1000 ppm in any case.

ii. Hardness

It is the property of water which prevents the lathering of soap. It is due to the presence of bi carbonates of calcium and magnesium and is termed as temporary hardness or carbonate hardness. It can be removed either by boiling or by adding lime to water. The permanent hardness or non carbonate hardness is due to sulphates and chlorides of calcium and magnesium. It cannot be removed by boiling. It requires water softening.

iii. pH value

The pH value of water indicates the logarithm of reciprocal of hydrogen ion concentration present in water. It is thus an indicator of the acidity or alkalinity of water. The pure water consists of positively charged (H^+) Hydrogen ions combined equally with negatively charged Hydroxyl (OH^-) ions. The water is said to be acidic when H^+ ions are excess than OH^- ions and the pH value ranges from 0 to 7. The

water is said to be alkaline when OH^- ion exceeds H^+ ion and the pH value ranges between 7 to 14.

iv. Chloride

Chlorides are generally present in water in the form of Sodium chloride E.g.: Common Salt. The amount of chloride present in the water is determined by titrating the sample of water with Silver Nitrate solution taking Potassium Chromate as buffer. The end point is the appearance of red colour. The permissible limit of chloride for drinking water is 250 mg/l.

v. Residual chlorine

The free chlorine which remains as residue in treated water after the contact period is called residual chlorine. It can be determined by two methods.

- a. Starch Iodide method
- b. Orthotolidine Arsenite method

vi. Iron and Manganese

They usually occur together. They should be less than 0.3 ppm in portable water. They produce rust spots on fabrics (clothes) and plumbing fixtures. They are determined by chlorometric principle. Iron is determined by persulphate method. They impart reddish brown colour to water.

3. Bacteriological Tests

The following tests are normally done for bacteriological examination of water

- i. Total count test
- ii. E-Coli test

i. Total count test

In this test, bacterias are cultivated on specially prepared culture medium of agar containing nutrients for bacteria. The diluted sample is incubated at 20°C for 48

Do
YOU
KNOW?

Largest water treatment plant in the world

Nearly one billion gallons of water are **processed** on an average day at the James W. Jardine Water Purification Plant in Chicago, Illinois, the largest water treatment plant in the world. This plant and the South Water Purification Plant serve nearly 5 million consumers in the City of Chicago and 118 outlying suburbs.

(1 gallon = 3.78541 litres)



Activity 2

Visit any treatment plant / pumping station available in your locality and submit a report for the functioning of the units.

hours or 37°C for 24 hours. The bacterias grow and multiply and form colonies or clusters. The bacterias thus formed are counted and the results are computed for 1cc. For portable water, the total count should not exceed 100 per cc.

ii. E-Coli test

It is also called as B-Coli test. In this method, the sample of water is filtered through a sterilized membrane containing microscopic pores of size 5 to 10 millimicron to retain bacterias. The membrane with retained bacterias is incubated for 20 hours at 37°C along with

nutrients. After this period, the membrane is taken out and the colonies of bacterias are counted by means of microscope. This method is called membrane filter technique.

4.4 Treatment of Water

Objectives of water Treatment

The following are the objectives of water treatment

- i. To remove the dissolved gases and colour from the water
- ii. To remove the unpleasant and objectionable taste from the water
- iii. To kill all the pathogens from the water
- iv. To remove corrosive materials from the water
- v. To make water fit for domestic and industrial purpose.

Flow Diagram of a Treatment plant (Refer Page 72)

Sequence of units

1. Intake point
2. Pump house
3. Plain Sedimentation tank
4. Coagulation tank
5. Filtration unit
6. Chlorination unit
7. Water softening plant
8. Overhead reservoir

4.4.1 Functions and locations of Treatment Units

The function of each unit is stated briefly

1. Intake point

The function of this unit is to collect water in the intake well so that the water can be supplied throughout the year.

2. Pump House

The function of this unit is to draw water from the intake point and to supply the same to the treatment plant.

3. Plain Sedimentation Tank

The function of this unit is to remove the heavier suspended particles in water. In this tank, the water is detained for some period or allowed to flow at a very low velocity so that heavier suspended particles are settled down at the bottom of sedimentation tank. But some lighter particles still remain in suspension.

4. Coagulation Tank

The function of this unit is to remove the lighter suspended particles by the application of some coagulants(chemicals). In this tank, some recommended coagulant is mixed with the water and the water is allowed to flow at a very low velocity through the coagulation tank. The coagulant makes the lighter particles to gain settleable size and ultimately settle down at the bottom of the tank. But some colloidal particles still remain in suspension.

5. Filtration unit

The function of this unit is to remove the finer colloidal particles and some bacteria by filtering media of sand and gravel. But some bacteria still remain in water.

6. Chlorination unit

The function of this unit is to destroy the bacteria by the application of chlorine.

7. Water softening tank

The function of this unit is to remove the hardness of water to make it

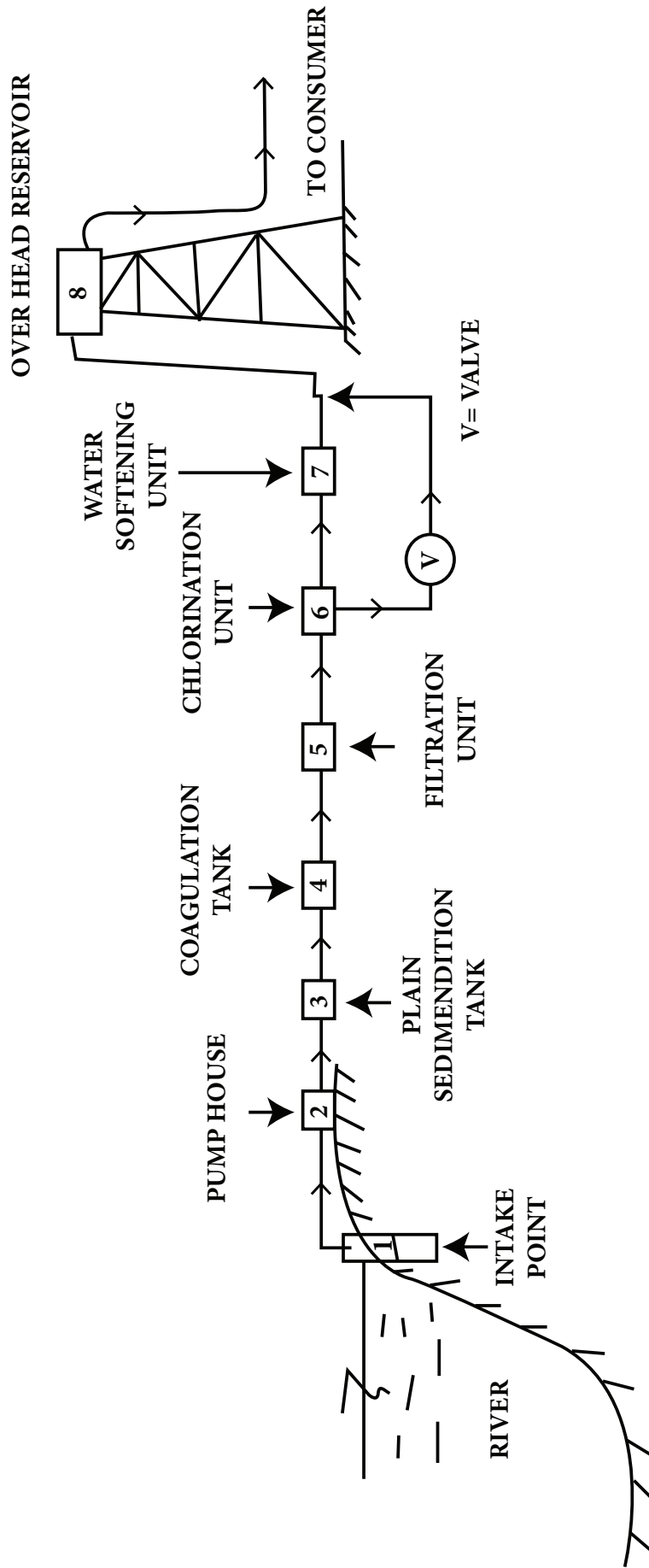

Flow Diagram of Treatment Plant

fit for commercial purpose. This unit is not always necessary.

8. Overhead Reservoir

The function of this unit is to store the purified water after the treatment is complete. The water from the reservoir is supplied to the consumers by gravity or pumping.

Location of Treatment units

The following points are to be considered while locating the plants for treatment of water

1. All plants should be located in such a sequence that water may flow from one process to the other automatically.
2. Elevation of different processes should ensure gravity flow from one to another.
3. All the processing units should require minimum area. For future expansion, adequate space should be available.
4. All the processing units should be nearer to the area of distribution for better working and efficient maintenance.
5. The site of treatment plant installation should be neat and clean and should be well protected.
6. A well equipped laboratory should be available at the treatment plant to have regular checking of the quality.
7. Space for the disposal of sludge from settling tanks and wash water from filters should be provided.

4.4.2 Screening

Water, when derived from the surface sources may contain floating

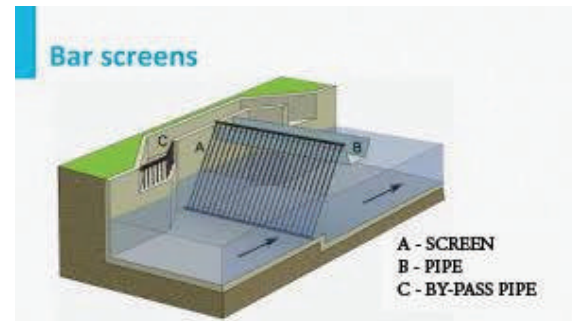

Bar screens

matters. Most of the big and visible objects such as trees, branches, sticks, vegetation, fishes, dead and floating animals, etc., can be removed by screening. (e.g.) Bar screens. Bar screens may be of two types.

1. Coarse screens
2. Fine screens

4.4.3 Sedimentation

It is the process of causing heavier solid particles in suspension both organic and inorganic, to settle by retaining the water in a huge tank called sedimentation tank.

Theory of Sedimentation

The particles heavier than water tend to settle down due to the force of gravity. Impurities in water are held in suspension due to the turbulence of the moving water. When this turbulence is checked and the velocity of flow is reduced, the suspended particles tend to settle down at the bottom of the tank. The settling velocity depends upon

1. The horizontal velocity of flow.
2. The shape and size of the particle.
3. The specific gravity of the particle.
4. The temperature of water.

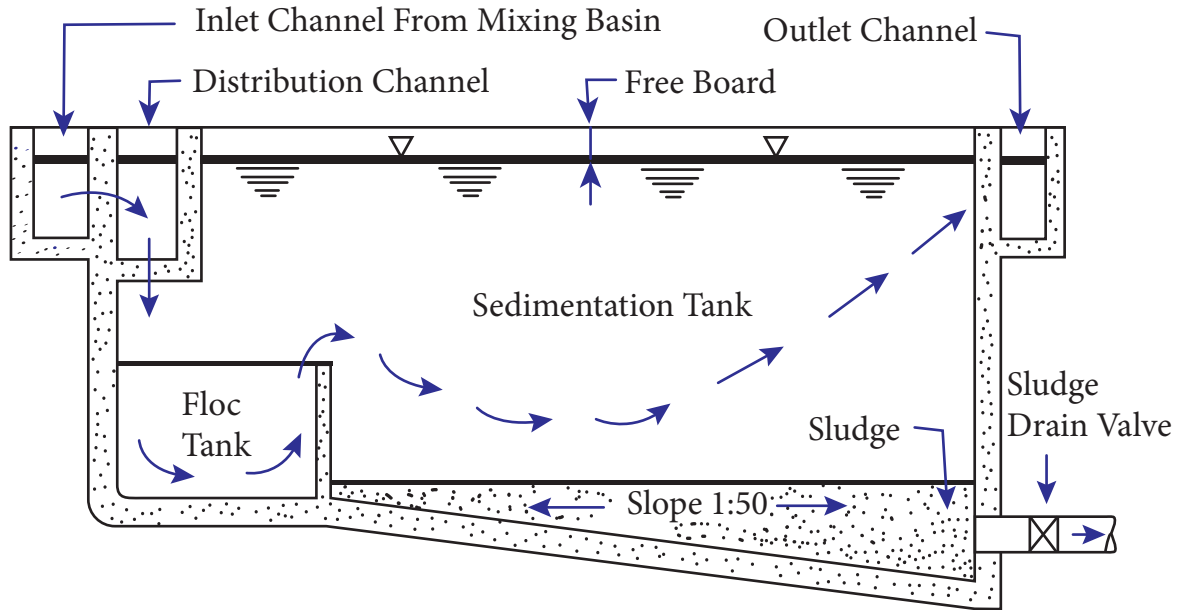

Sedimentation with coagulation

Types of Sedimentation

There are two types of sedimentation. They are

1. Plain sedimentation
2. Sedimentation with coagulation

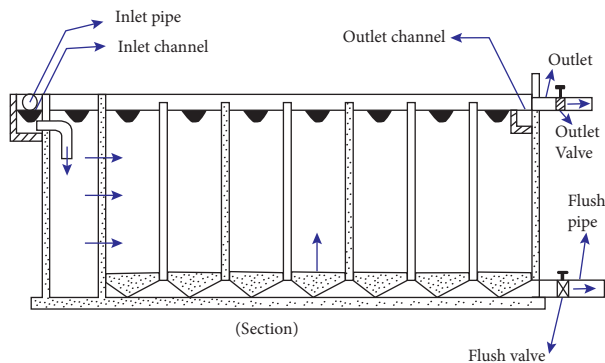

Plain sedimentation

1. Plain sedimentation

In this, the raw water is retained for sometime in a huge tank for the suspended particles to settle down by the action of gravity.

2. Sedimentation with coagulation

In this, certain chemical compound called coagulant is added to water to assist

sedimentation. The coagulant react with impurities in water and convert them into settleable solids.

4.4.4 Filtration

Filtration is the process of passing the water through the filter beds. Filtration removes colour, odour, turbidity and pathogenic bacterias from water.

Theory of filtration

The filtration involves the following actions

1. Mechanical straining
2. Sedimentation and absorption
3. Biological metabolism
4. Electrolytic changes

1. Mechanical straining

The filtering media contains a number of voids between the sand grains. When water is passed through these voids, the suspended particles which are bigger in size than the voids are retained on the surface of the sand bed. This action is called mechanical straining which removes the suspended particles.

2. Sedimentation and Absorption

The voids between the sand grains act as minute sedimentation basins. The colloidal matters arrested in these voids is in a gelatinous mass. Therefore, it attracts other finer particles by absorption.

3. Biological Metabolism

It is the growth and life process of living cells. When bacterias are caught in the voids of sand grains, the surface layer gets coated with a biological film. This film contains large colonies of living bacterias. They feed on the organic impurities present in water. They convert such impurities into simple harmless compounds by biochemical action. This results in the filtration of water.

4. Electrolytic Changes

The sand particles of filter media and ionized matter in water carry electrical charges of opposite nature. Hence, they attract each other and neutralize the charge of each other. This results in the alteration of chemical characteristics of water.

Types of filters

The filters are mainly classified as

1. Slow sand filters
2. Rapid sand filters
3. Pressure filters

The terms rapid and pressure represent high rate of filtration and slow indicate low rate of filtration.

1. Slow sand filters

A slow sand filter is a water tight tank of 2.5 to 3.5 m in depth. It has a sand bed of 1 to 1.5 m thick, supported by a 0.3 to 0.75 m thick layer of graded gravel or broken stone (25 to 50 mm size), laid in layers. Beneath this, an under-drainage system consisting of open-jointed drains is laid over a concrete bed sloping towards

a central longitudinal drain. The filtration is effected by gravity.

The rate of filtration is 100 to 200 lits/m²/hour. It's bacterial efficiency is 98 to 99%. The filter bed is cleaned by scraping. This type of filter is unsuitable for waters having turbidity more than 50 ppm.

A typical plan and longitudinal section of a slow sand filter is shown in fig. It consists of the following essential parts.

- i. Enclosure tank
- ii. Filter media
- iii. Base material
- iv. Under-drainage system
- v. Inlet and outlet arrangement
- vi. Other appurtenances

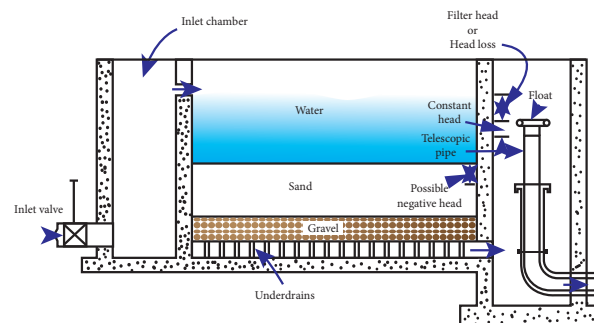

Section of Slow Sand Filter

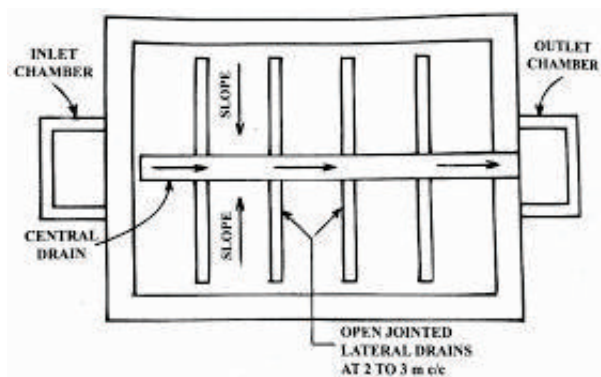

Plan of Slow Sand Filter

Working

The treated water from the sedimentation tank is allowed into the inlet chamber. It is uniformly distributed over the sand bed to a depth of 1 to 1.5 m without any disturbance. The water percolates through the filter media and gets filtered. Now the water enters the base material and comes out as filtered water. It gets collected in the laterals and discharged into the central main covered drain. Then it is finally discharged into the filtered water well. The standard rate of filtration (100 to 200 litres/m²/hour) is continued until the difference between the water levels in the filter and the outlet chamber is slightly less than the depth of water above the sand or the loss of head reaches 0.7 to 1.2 m.

Cleaning

During working of the filter if the loss of head reaches the permissible limit, the filtration is stopped. About 20 to

30 mm sand is scraped from the top of the filter bed. The top surface is finally raked, roughened, cleaned and washed with pure water till the sand depth reduces to 0.4 m or so. Then more clean sand is added to have a minimum sand depth of about 0.45 m. The interval of cleaning may vary from 1 to 3 months.

After every cleaning, the initial filling is done by admitting filtered water from the bottom till it rises about 0.8 m above the sand. Then the fresh water is allowed to enter from the top.

2. Rapid sand filters

In rapid sand filters, the yield is about 30 times the yield given by slow sand filters for the same filter area. This is achieved by increasing the size of sand. They are also known as mechanical sand filters.

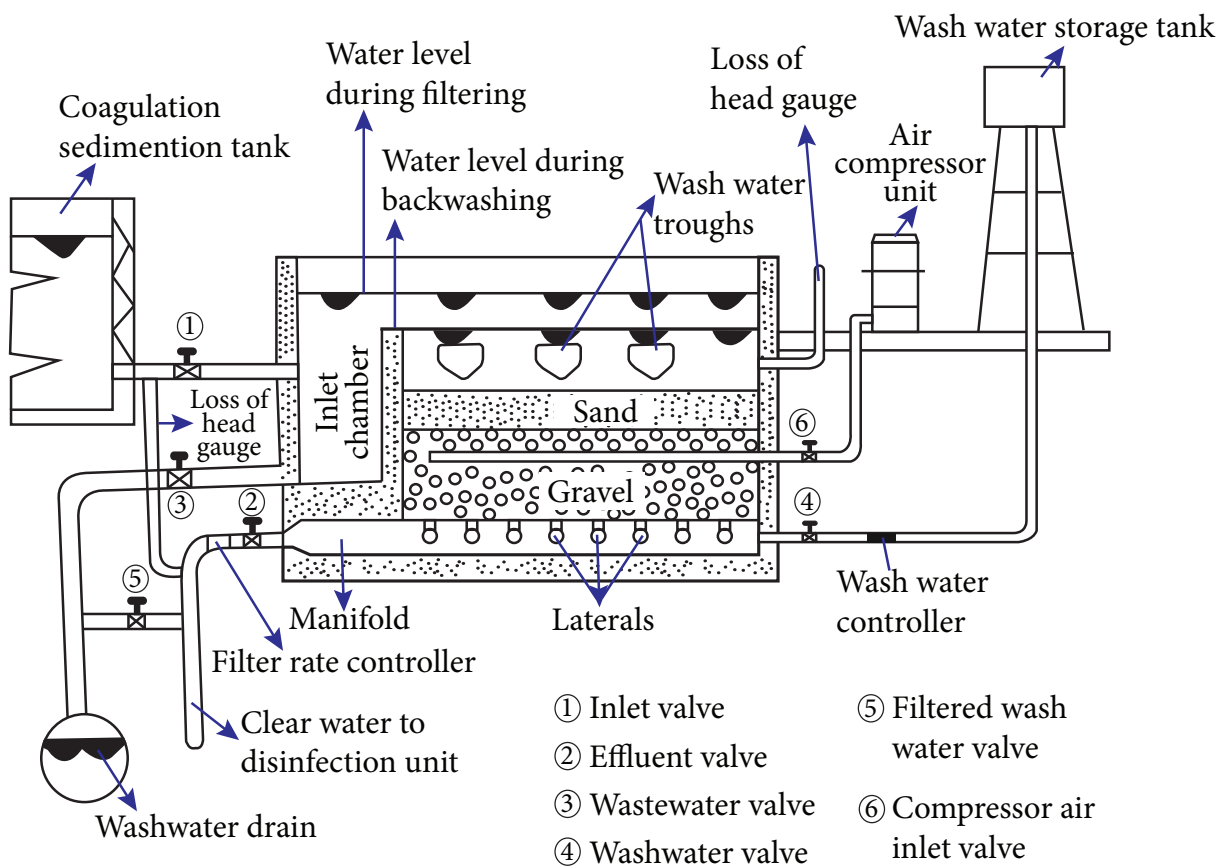

Longitudinal section of a rapid sand filter

A rapid sand filter is an open water tight chamber, 3 to 3.5 m deep. It has coarse sand filter media, 0.6 to 0.75 m thick, laid on 0.45 m thick graded gravel. The under-drainage system is supported by concrete floor. The under-drainage system consists manifold with strainers mounted on top and laterals. Laterals have perforations on sides. The filtration is effected by gravity.

The rate of filtration is about 3000 to 6000 litres/m²/hour. Its bacterial efficiency is 80 to 90%. It removes turbidity upto 30 to 40 ppm.

A typical longitudinal section of a rapid sand filter is shown in fig. The following are its essential parts

- i. Enclosure tank
- ii. Filter media
- iii. Base material
- iv. Under-drainage system
- v. Appurtenances

Action during filtration

Inlet valve is opened and water from coagulated sedimentation tank is allowed to enter the filter. Effluent valve is opened to carry filtered water to clear water reservoir. During this time all other

valves remains closed. Only inlet and effluent valves are opened.

Action during backwashing

Backwashing is done when the loss of head reaches the maximum permissible limit of 2.5 to 3.5 m. The filter is drained out leaving a very small depth of water standing above the filter bed. Now, the compressed air is sent under pressure through the under drainage system for about 2 to 3 minutes. This agitates the mass of water. The agitated water loosens the dirt from the surface of sand grains. Then, an upward flow of water from a high level tank is sent through the bed. This causes the sand bed to expand, agitate the sand grains and wash off the surface deposits. The deposits are carried by wash water troughs and disposes through wash water drains. During backwashing the valve positions are the inlet and effluent are closed, and the valves of wash water trough and wash water drains remains open.

3. Pressure Filters

They consist of closed watertight cylindrical metal tanks of 1.5 to 3 m diameter and length or height 3.5 to 8 m. It contains filter media as of rapid sand filter. The raw water mixed with a dose of coagulant is

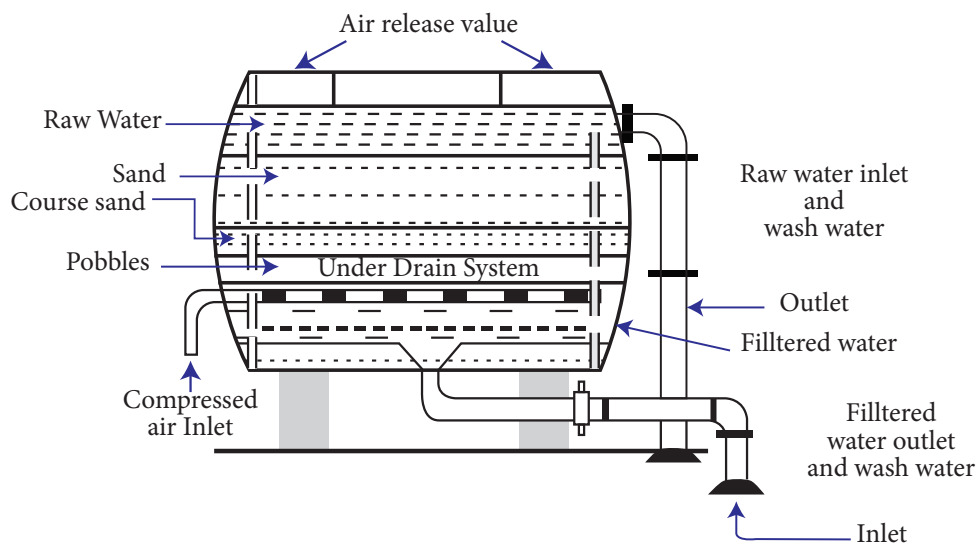

Horizontal pressure filter (sectional view)

pumped into the filter under a pressure of 200 to 700 kN/m². After filtration, water comes out under high pressure. The rate of filtration is 6000 to 15000 litres/m²/hour. They are of horizontal or vertical type. They are more suitable for industries, private estates, etc. They are less efficient than slow and rapid sand filters. Inspection windows are provided at the top. A horizontal type of filter is shown in fig.

Working

The coagulated water under pressure is directly admitted to the pressure filter through inlet valve. The filtered water comes out through the outlet valve. It is collected in the central drain and conveyed to filtered water storage tank. During normal working, only the valves for raw water and filtered water are kept open.

The cleaning of the filter may be carried out by backwashing like rapid sand filter. The compressed air may be used to agitate sand grains. For cleaning, inlet and outlet valves are closed. The wash water valve and wash water gutter valve are opened. The cleaning is done more frequently.

4.5 Disinfection of Water

Disinfection of water is the process of removal of pathogenic bacteria from water by chemical or other means.

The chemicals used for killing disease producing bacteria are known as disinfectants.

4.5.1 Necessity of Disinfection

The filtered water may contain some harmful impurities such as disease producing bacteria, dissolved inorganic salts, colour, odour, taste, iron and manganese. The bacterially contaminated water will spread

various diseases and their epidemics causing disaster to public life. Hence, disinfection is most essential. Further disinfection not only kills the existing bacteria from water, but also prevents its contamination during its transit from the treatment plant to place for its consumption.

4.5.2 Methods of Disinfection

There are two methods of disinfection of water. They are:

- (i) Chlorination
- (ii) Minor methods

(i) Chlorination

Chlorine has been universally recognized as the most ideal disinfectant in treatment of water on a large scale.

The treatment by chlorination is cheap and reliable. It produces desired effects and lasts long. It is also easy to measure and handle. Chlorination is the treatment of water with chlorine or its compounds for the disinfection of water.

Chlorination not only disinfects, but also removes colour, odour, unpleasant taste and prevents the growth of weeds in water.

(ii) Minor methods

1. Boiling
2. Excess lime treatment
3. Iodine and bromine treatment
4. Ozone treatment
5. Potassium permanganate treatment
6. Silver treatment
7. Ultra-violet rays treatment

The most commonly adopted two minor methods of disinfection of water are discussed below.

1. Boiling

Continuous boiling of water for a long time above a certain temperature kills the bacterias. It is the most effective method of disinfection. It is highly impracticable to boil water on large scale for public water supplies. However, during water borne epidemics, it is advisable to boil water before consumption.

2. Excess Lime Treatment

Addition of excess lime to water removes salts and also kills the bacterias. Use of excess lime increases the pH value of water. When the pH of water rises to about 9.5 or so, 99.93 to 100% bacterias are removed even from highly polluted waters.

After disinfection, by adopting some suitable method the excess lime is removed from water before its public supply. Further this method cannot protect water from recontamination.



Activity 3

Collect the data regarding disinfection of water in your locality.

4.6 Water Softening

Water softening is the process of reduction or removal of hardness from water.

4.6.1 Purpose of water softening

1. To reduce soap consumption
2. To reduce corrosion and incrustation of pipes and fittings
3. To improve the taste of food preparations
4. To reduce scaling in boilers

5. To minimise its interference in dyeing systems

4.6.2 Hardness of Water

It is the characteristic which prevents the lathering of soap. It is caused by the presence of certain salts of calcium and magnesium dissolved in water.

Hardness of potable water is 5 to 8 degrees. Hardness less than 5 degrees is tasteless and above 8 degrees produces undesirable effects. (One degree of hardness = 14.25 ppm).

Types of Hardness

1. Temporary hardness or Carbonate hardness
2. Permanent hardness or Non-carbonate hardness

Temporary hardness is due to the presence of bicarbonates of calcium and magnesium. Permanent hardness is caused by the presence of sulphates and chlorides of calcium and magnesium.

1. Removal of temporary hardness

The temporary hardness can be removed by boiling or by adding lime which is called as lime process. Lime process is otherwise known as clark process.

The principle involved in this process is the neutralization of carbon-dioxide with milk of lime.

2. Removal of permanent hardness

The permanent hardness can be removed by special methods of water softening. Any of the following methods can be adopted.

- i. Lime-soda process
- ii. Zeolite process or Base exchange process
- iii. Demineralisation

4.7 Distribution System of Water

Distribution of water is the supply of safe and wholesome water to all parts of the area served at adequate pressure and quantity. Hence, the distribution system may consist of the following

1. Pipe lines of different sizes to convey water.
2. Valves for controlling the flow in the pipe lines.
3. Meters for measuring the consumption.
4. Hydrants for providing connections with water mains for releasing water during fires.
5. Service connections to the individual houses.
6. Pumps for lifting and forcing the water into the distribution pipes.
7. Service reservoirs for storing the treated water and feeding to the distribution pipes.

Requirements of Good Distribution system

A good distribution system should satisfy the following general requirements

1. It should be capable of supplying water in adequate quantities and pressure at all points of the area served.
2. It should meet the demands of water supply for fire-fighting purposes.
3. It should be thoroughly reliable.
4. It should be economical in its design, layout and construction.
5. It should be easy and simple to operate and repair.
6. It should be safe against any future pollution of water.

7. It should be water-tight so as to keep the “losses due to leakage” to the minimum.
8. It should be safe and not cause the failure of the pipelines by bursting, etc.

Different Systems of supplying water

Depending upon the situation, the water supply system may be classified as below

1. Methods of distribution
2. Systems of water supply
3. Methods of Layout of distribution pipes

4.7.1 Methods of distribution

Depending upon the levels of water source and that of the area served, topography of the area served and other local conditions, following methods are adopted.

- a. Gravity system
- b. Pumping system
- c. Combined pumping and gravity system

a. Gravity system

In this system as shown in fig, treated water is conveyed at atmospheric pressure through pipes by gravity. This system is adopted when the source of water supply is situated at a higher level than the area served.

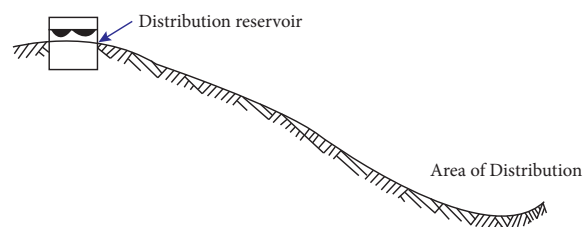

Merits

- i. Most safe, reliable and economical.
- ii. No pumping is required.

Demerits

- i. Source of water supply should be higher than the area served.
 - ii. During fire-fighting, it may require motor pumping to develop required pressure.
- b. Pumping system**

This system is followed when the source of water supply is lower than the area served or the ground between the source and the distribution area is undulating. In this system, treated water is pumped directly into the water distribution mains. Water flows under hydraulic pressure.

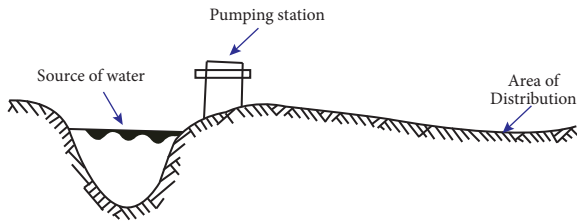

Merits

- i. The source of supply can be at any level.
- ii. No pumping during non-supply

Demerits

- i. Requires high lift pumps.
 - ii. Requires constant attention at pumping stations.
 - iii. Unreliable as it depends entirely on power supply.
 - iv. Pressure in mains varies as the variation in consumption.
- c. Combined pumping and gravity system**

In this system water is supplied by both gravity and pumping. When the demand is less than the rate of pumping, the excess water is stored in the reservoir. When the demand is more than the rate of pumping, the water from the reservoir is supplied for consumption.

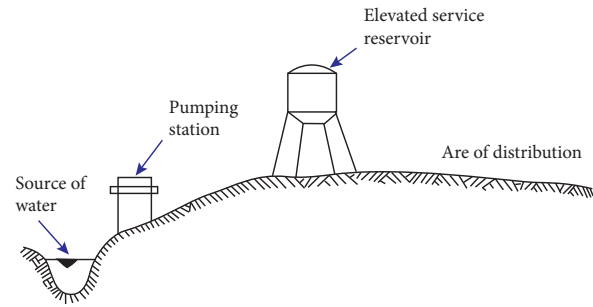

Merits

- i. Most economical, efficient and reliable.
- ii. Pumping can be done at uniform rate.
- iii. Pumps can operate at their capacities which results in higher efficiency and economy in operation.
- iv. Stored water can be used at all emergencies.

4.7.2 Systems of water supply

Based on the frequency of water supply, the following water supply systems may be followed.

- a. Continuous system
- b. Intermittent system

a. Continuous system

In continuous system, treated water is supplied to the consumers throughout the day.

Merits

- i. Most ideal.
- ii. No separate storage by the consumers is required.
- iii. Adequate supply is always available for fire-fighting.
- iv. Wastage is minimum.

Demerits

- i. The water supply source should have adequate quantity.
- ii. Wastage will be more if the consumers do not have civic sense.

b. Intermittent system

In this system, treated water is supplied to the consumers during certain fixed hours of the day. This system is used when the quantity of water is limited and the pressure in the system is low.

Merits

- i. Minimum wastage due to vigilant use of consumers.
- ii. Suitable if the source has only limited supply.
- iii. Repairs can be easily attended during non-supply hours.
- iv. Own storage of the consumers will relieve the situation during emergencies or non-supply.

Demerits

- i. The consumers have to store water for use during non-supply hours.
- ii. If emergencies such as fire occur during non-supply period, it causes great loss and hardship.
- iii. More wastage due to open tap, etc.

4.7.3 Methods of Layout of Distribution pipes

There are four systems of layout of pipes

1. Dead end or tree system.
2. Grid-iron system or interlaced system or reticulation system.
3. Circular or ring system.
4. Radial system.

1. Dead end or tree system

This system shown in fig, is more suitable to irregularly developed areas without any properly planned roads. This system consists of one supply main and from which many submains are taken. The submains again branch off into several branch lines. The branch lines divide into a number of service pipes.

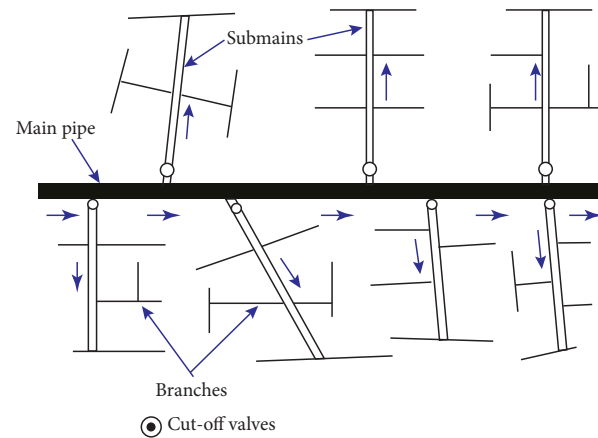

Merits

- i. Cheap and simple and can be expanded, extended easily.
- ii. Discharge and pressure calculations are easy, simple and accurate.
- iii. Requires less number of cut off valves.
- iv. Pipe lines can be laid in any pattern easily.

Demerits

- i. During repairs, large portion of distribution area is affected.
- ii. Water available for fire fighting will be limited.
- iii. The numerous dead ends of the system prevent the free circulation of water.
- iv. The stagnated water at dead ends may pollute.

2. Grid -Iron system

In this system shown in fig., the mains, submains and branches are all interconnected with each other. The dead ends are completely eliminated. This system is most suitable for well planned towns.

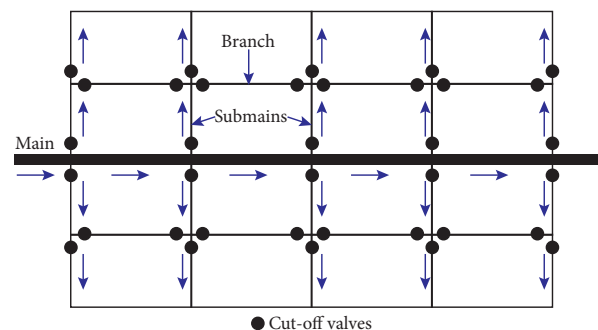

Merits

- i. There is free circulation of water. No possibility of pollution due to stagnation.
- ii. In case of repairs, only a very small portion of the distribution area will be affected.
- iii. Water reaches all the points with minimum loss of head.

Demerits

- i. Two or more valves are to be installed at every cross junction.
- ii. Laying water pipes is costly.
- iii. The design is difficult and costlier.

3. Circular or Ring system

In this system shown in fig, the entire distribution area is divided into square, rectangular or circular blocks. The water mains are laid on the periphery of these blocks. The submains, branches, etc., are laid along the inner roads and streets. This system is most suitable for cities having well planned roads and streets.

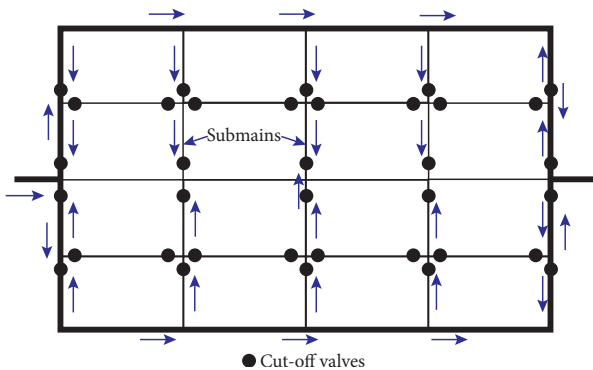

Merits

- i. This system has the advantages of the previous two systems.
- ii. In this systems, every point receive its supply from two directions.
- iii. Design of this system is easy.

Demerits

This system has the same disadvantages as the grid-iron system.

4. Radial system

This system of layout shown in fig., is just the reverse of the ring system. The entire distribution area is divided into distributed zones. There is a central distribution reservoir in each zone. The supply pipes are laid radially away from the reservoir towards the periphery. The water from the mains flow into these reservoirs. From there it is supplied to the respective zones.

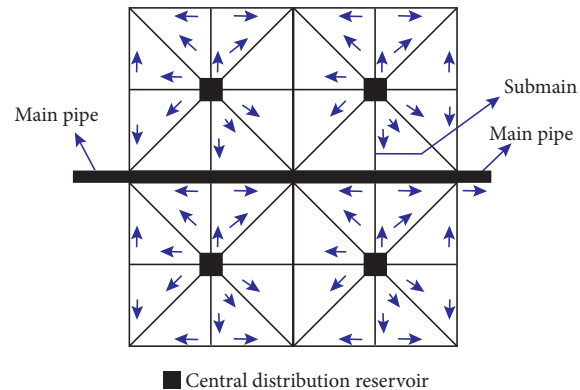

Merits

- i. Provides good service quickly.
- ii. Design calculations for the sizes of the pipes are simple.
- iii. Best suited where the roads are laid radially.

Demerits

Requires a distribution reservoir in each zone.



MODEL QUESTIONS

Part – I

Choose the Correct answer (1 Mark)

- The standard recommendation of the quantity of water required for domestic purpose is _____.
 a. 270 liters per capita per day
 b. 135 liters per capita per day
 c. 180 liters per capita per day
 d. 125 liters per capita per day
- Distilled water is safe water as it is _____.
 a. Bacteriologic ally pure
 b. Chemically pure
 c. Bacteriologically and Chemically pure
 d. Bacteriologically pure and Chemically not pure
- For drinking water, the permissible turbidity is _____.
 a. 5 to 10 PPM
 b. 10 to 15 PPM
 c. 15 to 20 PPM
 d. 20 to 25 PPM
- The Permissible limit of chloride for drinking water is _____.
 a. 500 mg/l c. 400 mg/l
 b. 300 mg/l d. 250 mg/l
- The rate of filtration of a slow sand filter is _____.
 a. 100 to 200 liters/m²/hour
 b. 500 to 1000 liters/m²/hour
 c. 2000 to 3000 liters/m²/hour
 d. 3000 to 6000 liters/m²/hour
- Hardness of portable water is _____.
 a. 4 to 6 degrees
 b. 5 to 8 degrees
 c. 6 to 7 degrees
 d. 7 to 10 degrees



- The water is said to be alkaline when Ph value ranges from _____.
 a. 0 to 7 c. 7 to 14
 b. 5 to 10 d. 8 to 15

Part – II

Answer in one or two sentences (3 Marks)

- List the name of the tests to determine impurities in water.
- List the various types of water demand.
- Name the various sources of water.
- Write any two objectives of water treatment.
- Define Sedimentation.
- Define Chlorination.

Part – III

Answer in brief (5 Marks)

- What are the objectives of public water supply schemes?
- What are the points to be considered while locating the water treatment units?
- Define filtration and list the actions involved.
- What are the general requirements of a good distribution systems.

Part – IV

Answer in detail (10 Marks)

- Explain the factors affecting per capita Demand.
- Explain the construction and working of a slow sand filter with a neat sketch.
- Explain the construction and working of a Rapid sand filter with a neat sketch.
- What are the different systems of supplying water and explain in detail.

1) b 2) c 3) a 4) d 5) a 6) b 7) c

Answers:

UNIT 5

SANITARY ENGINEERING



“ Move your lymph system. Lymph is like a sewage system that carries all of the toxins out of your body ”

Valentina Zelyaeva



Table of Contents

5.1 Introduction

- 5.1.1 Purpose of Sanitation
- 5.1.2 Terms used in Sanitation

5.2 Collection and Conveyance of Refuse

- 5.2.1 Systems of Sanitation
- 5.2.2 Systems of Sewerage

5.3 Quantity of Sewage

- 5.3.1 Dry Weather flow
- 5.3.2 Storm Water

5.4 Constructions of Sewers

- 5.4.1 Shape of Sewers
- 5.4.2 Gradient of Sewers
- 5.4.3 Laying of Sewer lines
- 5.4.4 Testing of Sewers
- 5.4.5 Ventilation of Sewers
- 5.4.6 Cleaning of Sewers
- 5.4.7 Sewer appurtenances

5.5 Quality of Sewage

- 5.5.1 Properties of Sewage
- 5.5.2 Analysis of Sewage

5.6 Treatment of Sewage

- 5.6.1 Primary treatment
- 5.6.2 Secondary Treatment
- 5.6.3 Tertiary Treatment

5.7 Septic Tank

- 5.7.1 Construction and Working of Septic tank

5.8 Sludge Disposal

- 5.8.1 Quantity of Sludge
- 5.8.2 Methods of Sludge disposal

5.9 Solid Waste Management

- 5.9.1 Solid wastes
- 5.9.2 Classification of Solid waste
- 5.9.3 Disposal of Solid wastes
- 5.9.4 Methods of Solid waste disposal

5.10 Pollution Control

- 5.10.1 Land Pollution
- 5.10.2 Water Pollution
- 5.10.3 Air Pollution

Learning Objectives

At the end of this lesson you shall be able to

- Understand the purpose of sanitation.
- Explain the quantity and quality of sewage.
- Know about Construction and testing of sewers.
- Describe the various processes involved in Sewage treatment Plant.
- Know the principles and working of septic tank.
- Get an idea about solid waste management.
- Explain the effects and prevention of various types of pollutions.

5.1 Introduction

Sanitary Engineering is the application of engineering method to improve sanitation of human communities. It is achieved by the removal and disposal of human waste to promote safe and healthy environment.

5.1.1 Purpose of Sanitation

1. To maintain safe environment.
2. Proper disposal of human excreta and waste water.
3. To avoid pollution of soil and water.
4. Reuse and recycling of waste and waste water.

5.1.2 Terms Used in Sanitation

1. Refuse

Refuse is a general term used to indicate which is rejected or left out as worthless. It may be in liquid, semisolid or solid form.

2. Garbage

It is the dry refuse and includes decayed fruits, grass, leaves, paper pieces, sweepings, vegetables, etc.

3. Sullage

It is the liquid waste from bathrooms, kitchens, washbasin, etc. It is merely a waste water and does not create bad smell.

4. Sewage

It is the liquid waste from the community. It includes sullage, discharge from latrines, urinals, industrial wastes and storm water.

5. Sewer

It is the underground conduit (or) drain through which sewage is conveyed.

6. Sewerage

The entire process of collecting and carrying sewage by water carriage system through sewers is known as sewerage.

7. Invert

It is the lowermost level (or) surface of a sewer.

8. Storm Water

It is the rain water of the locality.

9. Dry Weather Flow

It is the normal flow of sewage during the dry season of the year.

10. Wet Weather Flow

It is the normal flow of sewage during the rainy season of the year.

11. Sludge

It is the organic matter deposited at the bottom of the sedimentation tank during the treatment of sewage.

5.2 Collection and Conveyance of Refuse

The two methods which are mainly adopted for the collection and disposal of refuse are as follows

1. Dry (or) Conservancy system
2. Water carriage system

5.2.1 Systems of Sanitation

1. Dry or Conservancy System

In this system garbage is collected, carried and disposed off by burning or burying. Sullage is collected in open drain and let off in natural water bodies. Night soil is removed by labour and conveyed outside the town to form manure.

2. Water carriage System

It is the most hygienic system. In this system, sewage is collected in a system of pipes and transported for treatment and disposed in a harmless manner without causing any nuisance.

Merits

1. It is hygienic.
2. No labour is required.
3. Maintenance cost is low.
4. Collection and conveyance is easy even in multi-storeyed buildings.
5. Modern methods of treatment can be given in this system.

Demerits

1. Needs large quantity of water.
2. Initial cost of construction is high.



Histry of sanitation

1854: Dr John Snow showed that cholera was spread by water. **1860:** The first septic tank was constructed by Louis Moureas and used by communities to remove solids from waste water before the liquid was discharged into water body. This design was improved by use of trickling sand filtration from **1893**.

5.2.2 Systems of Sewerage

The three systems of sewerage are as follows

1. Separate system
2. Combined system
3. Partially separate system

1. Separate System

In this system two sets of sewers are laid. One for carrying sewage and another for carrying storm water. The sewage is carried to the treatment plant and the storm water is directly discharged into outlet in the form of river (or) stream.

2. Combined System

In this system, only one sewer is laid and it carries both sewage and storm water. The sewage and storm water are carried to the sewage treatment plant.

3. Partially Separate System

In this system, arrangement is made to permit early washings by rain into sewer carrying sewerage. When the quantity of storm water exceeds a particular limit it is collected and conveyed in open drains to the natural river (or) stream.

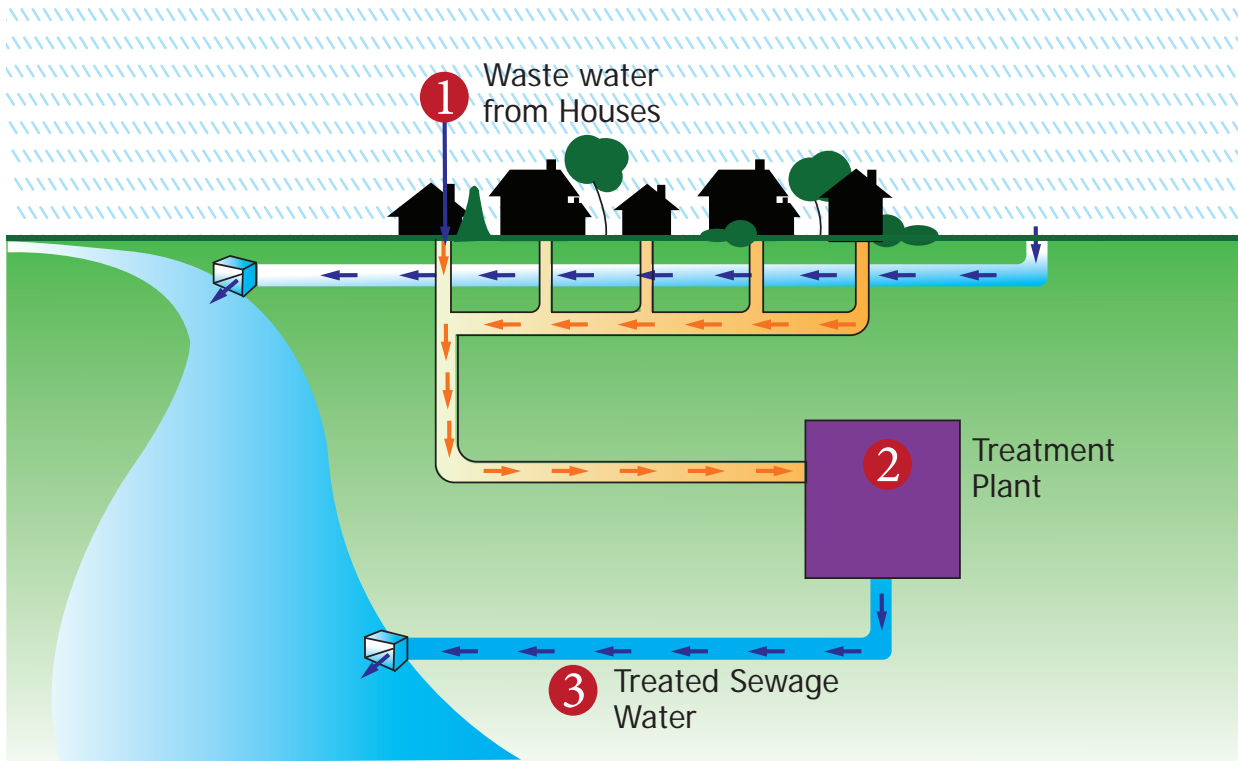

Separate Sewer System

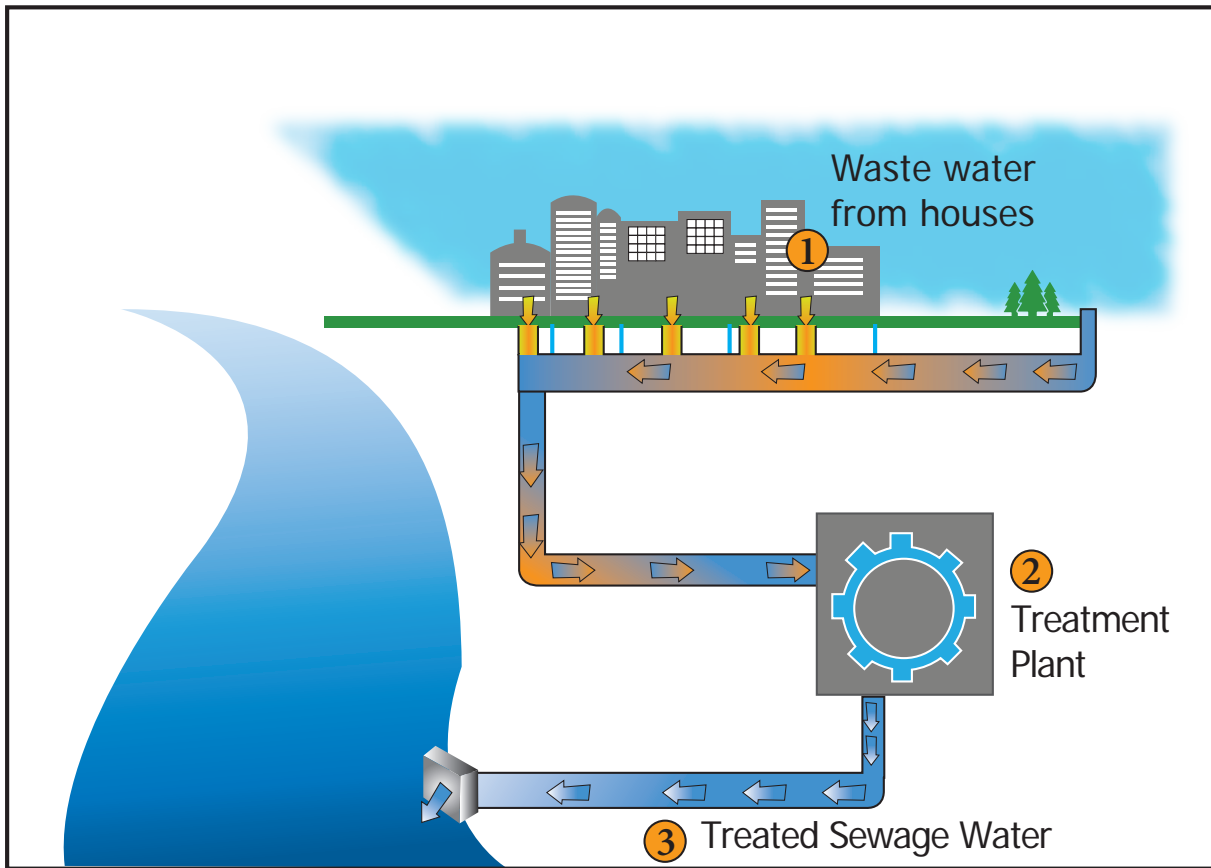

Combined Sewer System

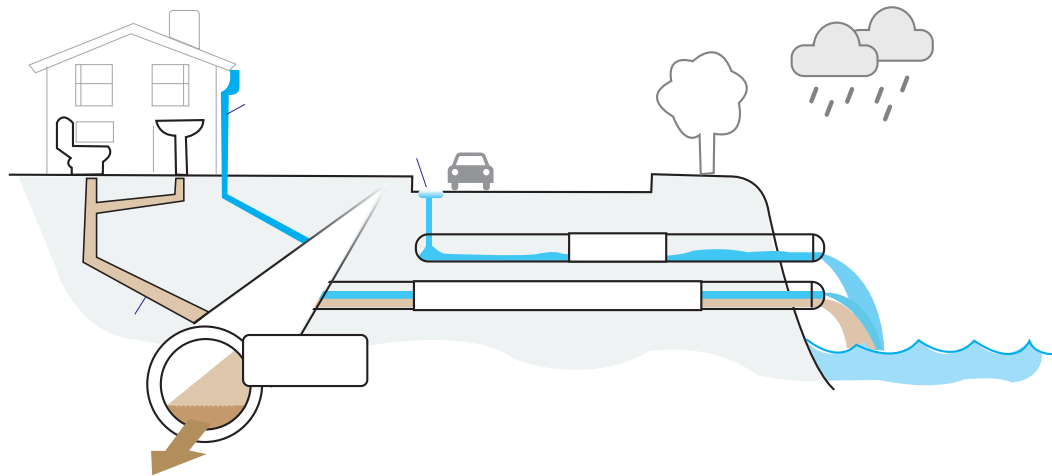

Partially Separated System

5.3 Quantity of Sewage

Generally, sewage denotes domestic and industrial waste water. The quantity of sewage depends on the population and the quantity of water utilised.

The sewage is categorised into two types

1. Dry weather flow
2. Storm water

5.3.1 Dry Weather flow

During Dry weather i.e. summer season without rain, the total quantity of sewage flows through the sewer line is called as “dry weather flow”.

Factors affecting dry weather flow

1. Infiltration and exfiltration of ground water
2. Location of industries
3. Population
4. Rate of water supply

5.3.2 Storm Water

During rainfall, the rainwater flows over the surface as storm water.

The quantity of storm water is affected by various factors such as

1. Intensity of rainfall

2. Characteristics of catchment area
3. Duration of Storms, etc.

5.4 Construction of Sewers

The construction of Sewers is discussed under the following topics.

1. Shape of Sewers
2. Gradient of Sewers
3. Laying of Sewers
4. Testing of Sewers
5. Ventilation of Sewers
6. Cleaning of Sewers

5.4.1 Shape of Sewers

The efficiency of the flow depends on the cross section of the sewer. Usually circular sewers are adopted in practice.

The sewer sections are broadly classified into

- a. Circular Sewer sections
- b. Non-Circular Sewer sections

a. Circular Sewer sections

They are easy to manufacture or construct and handle. They are best suited for diameter up to 1.5 m and are useful in separate system.

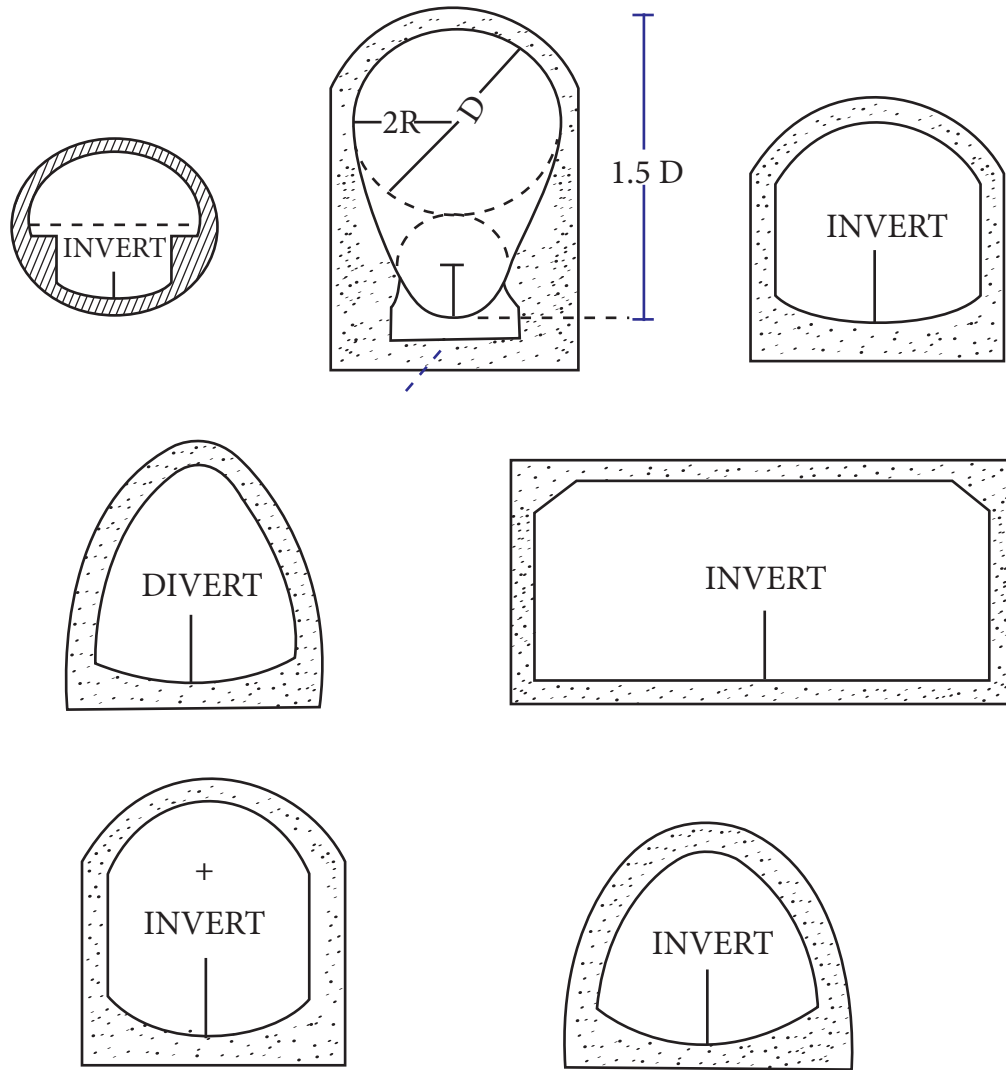

b. Non-Circular Sewer sections

The commonly used non-circular sewer sections are as follows

1. Basket hand sewer section
2. Horse shoe sewer section
3. Egg shape sewer section
4. Parabolic sewer section
5. Rectangular sewer section
6. Semi-circular sewer section
7. Semi-elliptical sewer section
8. U-shape sewer section

5.4.2 Gradient of Sewers

If the quantity of sewage is less, the solid matter may be accumulated in the sewer. This accumulation of solids may lead to blocking of sewer drains.

To overcome this difficulty, sewer pipes should be laid with sufficient gradient to ensure smooth gravity flow.

The National building Organisation (NBO) has suggests the following gradients

| | | | |
|-------------------|---------|----------|----------|
| Pipe diameter (m) | 1.00 | 1.50 | 2.25 |
| Gradient | 1 in 60 | 1 in 100 | 1 in 120 |

Self-cleaning and Non-Scouring Velocity in sewers

A certain minimum velocity has to be maintained to avoid silting and clogging in the sewers. Such a minimum velocity is known as **self-cleaning velocity**.

To keep the sewers free from any trouble, this velocity should be developed at least once in a day, preferably twice.

The maximum permissible velocity at which no scouring action (wear and tear) takes place is known as **non-scouring velocity**.

Non-scouring velocity mainly depends on the materials used in the construction of sewers.

5.4.3 Laying of Sewer lines

In the sewerage system, setting out of alignment is generally started from the tail end on the downstream and proceed upwards. The procedure to be adopted for the laying of a new sewer is as follows

- Borings (or) trial holes are dug along the proposed sewer line to know the nature of soil.
- The exact position of manholes are located with the help of sewage plan (or) working drawings.
- The centre line of sewer between two manholes is marked on the surface of the ground. The length between two successive manholes should be straight.
- Along the straight line, pegs are driven at convenient distance.

There are two methods for laying the new sewer line. They are:

- Offset line method
- Sight rail method

a. Offset line method

In this method, a line parallel to the centre line of the sewer is marked on one side which is known as Offset line.

It is usually marked at a distance of 'D' which is about one half the trench width plus 600mm as shown in fig.

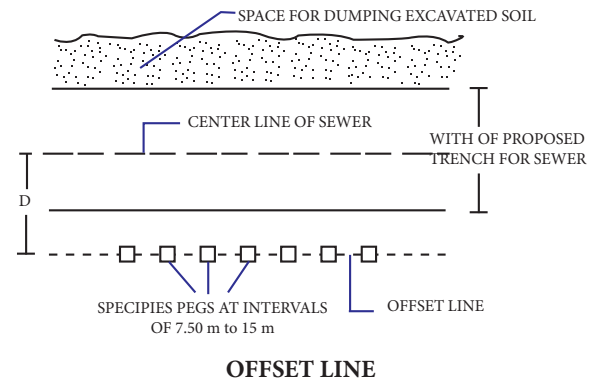

The Offset line helps in locating the centre line of the sewers when excavation is being carried out. The other side is used to dump the material.

b. Sight Rail Method

- In this method two vertical posts are driven into the ground at a known distance from the centre line of the peg on either side. The horizontal members known as Sight rails are held in position with vertical posts.
- The line joining the top of the sight rails will give the gradient of the sewer to be laid. This slope is transferred to ground with the help of a boning rod.
- After laying the sewer pipes, the levels are checked once using a levelling instrument.

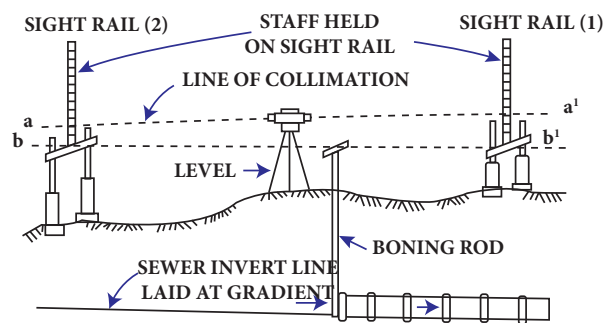

Laying of sewer

5.4.4 Testing of Sewers

The sewer line laid should be tested before it is put in to use. The tests to be done are as follows

- a. Water tightness test
- b. Obstruction test
- c. Straightness test

a. Water tightness test

After constructing the sewer, some period of time should be given for the joints to become hard and strong.

The water tightness of the joints is carried out between two manholes whether it is capable of withstanding 1.5m of pressure head by the following procedure

- The manhole at lower end of the sewer line is provided with a plug by using rubber bag with canvas cover and it is tightly closed.
- Water is filled in the manhole at the upper end of the sewer line.
- The depth of water in the upper end manhole is maintained at 1.5m.
- If the water level gets reduced, it indicates leakage and the corresponding pipe is replaced.

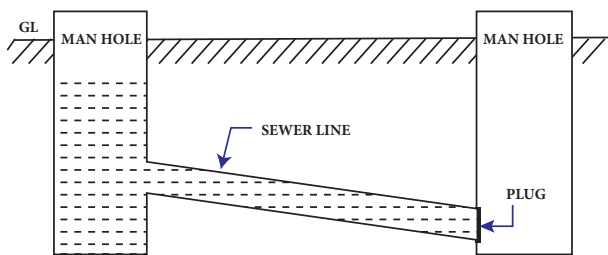

TESTING OF SEWER LINE

d. Obstruction test

In this test a smooth ball less than the diameter of the sewer pipe is inserted at the high end of the sewer (or) drain. In the absence of obstruction, the ball shall roll down in the invert of the pipe and emerge at the lower end.

c. Straightness test

In this test a mirror is placed at one end and a lamp is placed at the other end. If the pipeline is straight, the full section of the sewer is observed in the mirror, otherwise this would be apparent. The mirror will also indicate any obstruction in the sewer line.

5.4.5 Ventilation of sewers

The ventilation of sewer is essential for the following reasons

1. To avoid nuisance causing unpleasant odours.
2. To avoid the accumulation of explosive and poisonous gases and vapours.
3. To avoid airlocks in the sewers.
4. To relieve air pressure above (or) below atmospheric pressure caused by sudden rise or fall of sewage.

Methods of Ventilation

1. Proper design of sewers
2. Proper construction of sewers
3. Providing manholes with gratings
4. Providing ventilating columns (or) shafts
5. Providing unobstructed outlets

5.4.6 Cleaning of Sewers

Once the sewers laid and buried, they are liable to corrosion, deterioration, erosion, etc. Therefore the sewers should be properly cleaned and maintained in good working condition.

For the following reasons, the sewers are to be cleaned:

1. Breakage of sewers
2. Clogging of sewers
3. Odours in the sewers

Methods of cleaning of sewers

- a. Cleaning and flushing
- b. Cleaning of catch pits, etc.



Activity 1

Collect pictures of various methods of cleaning of sewers and prepare an album

5.4.7 Sewer appurtenances

They are the additional structures constructed at suitable intervals along the sewer line. They are constructed for the efficient working and maintenance of sewerage system.

The important sewer appurtenances are as follows

1. Manhole
2. Drop Manhole
3. Lamp hole
4. Catch basins
5. Clean out
6. Flushing tanks
7. Inlets
8. Grease and oil traps
9. Inverted syphons
10. Storm water regulators

5.5 Quality of Sewage

The quality of sewage plays an important role in the design of sewer and construction of various treatment units. Also the quality of sewage decides the method of treatment to be adopted.

5.5.1 Properties of Sewage

1. Physical characteristics
2. Chemical characteristics
3. Biological characteristics

1. Physical Characteristics

The sewage has the following physical characteristics

a. Odour

Fresh sewage is odourless. When it becomes stale, it has an offensive odour by hydrogen sulphide and other sulphur compounds.

b. Colour

If the sewage is fresh the colour of the sewage is yellowish grey or light brown. If the sewage is septic or stale, then the colour is black or dark.

c. Turbidity

The turbidity of the sewage directly depends on the quantity of solid matter present in suspension. Sewage is normally turbid.

d. Temperature

The normal temperature of the sewage is slightly higher than the water supplied for various uses. When the sewage flows through closed conduits, its temperature further rises.

This affects the biological activity, solubility of gases and viscosity of sewage.

2. Chemical Characteristics

This indicates the state of sewage decomposition, its strength and types of treatment required. Fresh sewage is alkaline and good for bacterial action. Stale or septic sewage is acidic and difficult to treat efficiently.

The chemical characteristics depends upon the substances contained in the sewage. The substances are complex organic (derived from urine, human-excreta) and inorganic chemicals.

3 Biological Characteristics

It is necessary to know the biological characteristics of sewage due to the

presence of living organisms like algae, protozoa and fungus. Most of the bacteria do not cause harm. Moreover they help in the decomposition of organic wastes naturally. Because of this, the cost of treatment also gets reduced.

5.5.2 Analysis of Sewage

Objectives

The analysis of sewage is carried out with the following objectives

- (i) To ascertain various substances present in the sewage
- (ii) To determine their physical, chemical and biological characteristics
- (iii) To obtain information regarding the operation and maintenance of the sewage treatment works.

Types of Analysis

1. Physical analysis
2. Chemical analysis
3. Biological analysis

1. Physical analysis

This includes tests for temperature, turbidity, colour and odour. The

determination of these tests are similar to that of water.

2. Chemical analysis

This includes tests for total solids, oxygen, nitrogen, pH value, chloride, fats and grease.

3. Biological analysis

Biological (or) bacteriological analysis is not considered on account of the fact that a high concentration of bacteria remains in the sewage even after the treatment.

5.6 Treatment of Sewage

Before disposing the sewage into river, stream, etc., it is essential to treat the sewage. The treatment of sewage depends on the characteristics of the wastes.

The treatment process involved the following steps.

1. Primary treatment
2. Secondary treatment
3. Tertiary treatment

| Primary | Secondary | Tertiary |
|------------------------|-------------------------------|----------------------------|
| 1. Screening | 1. Filters | 1. Disinfection |
| 2. Skimming tanks | (i) Contact beds | 2. Removal of Heavy Metals |
| 3. Grit Chamber | (ii) Intermittent Sand filter | |
| 4. Sedimentation Tank | (iii) Trickling Filter | |
| a. Primary Clarifier | (iv) Miscellaneous Filter | |
| b. Secondary Clarifier | 2. Activated Sludge Process | |



World's Largest Sewage Treatment Plant



Stickney Water Reclamation Plant located in Chicago is the largest sewage plant in the world. It has a daily capacity of 1.44 billion gallons. It's owned by Metropolitan Water Reclamation District (MWRD).

Flow diagram of sewage treatment system



5.6.1 Primary treatment

The main aim of this treatment is to remove floating and settleable solids from waste water. It includes physical operation such as screening and sedimentation.

a. Screens

In this method, sewage is passed through different sizes of screens. It is used to retain solid materials such as cloth, paper, wooden material, rubber, cork, etc.

b. Skimming tanks

Skimming tanks are used to remove oil and grease from the sewage. It is placed before the sedimentation tanks.

c. Grit chamber

Grit chamber are used to remove inorganic particles such as sand, gravel, grit, egg shells, etc. They are located before pumping station and after the screen.

d. Sedimentation tank

Very fine suspended inorganic matters can be removed only in sedimentation tanks. When the velocity of water is reduced in sedimentation tanks the suspended particles settles down.

According to location, sedimentation tanks can be classified into two types

1. **Primary clarifiers**-They are located just after the grit chamber
2. **Secondary clarifiers**-They are located after secondary treatment units.

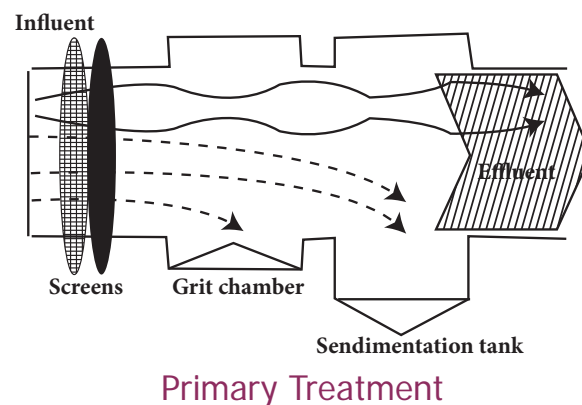

5.6.2 Secondary Treatment

The secondary treatment includes treatment units such as filters, aeration tanks, activated sludge process, oxidation ponds, aeration lagoons, septic tanks, Imhoff tanks, etc.

1. Filters

The different types of filters that may be used in sewage treatment are

- i. Contact beds (or) Contact filters
- ii. Intermittent Sand filters
- iii. Trickling filters

2. Activated Sludge Process

The effluent from primary sedimentation tank is mixed with activated sludge (20-30%) containing a large concentration of active aerobic micro organisms and with large quantity of air for about 4 to 8 hours.

Under these conditions, the micro-organisms will oxidise the organic matter, and the suspended and colloidal matter tend to coagulate and form a precipitate

which settles down in the secondary settling tank. This settled sludge is known as activated sludge. The process of settling the activated sludge is known as activated sludge process.

5.6.3 Tertiary Treatment

Nitrogen and Phosphorous which are not removed in the secondary treatment are removed by tertiary treatment. This includes disinfection and removal of heavy metals.

1. Disinfection

It is the process by which the pathogenic bacteria can be removed by adding chlorine with effluent.

2. Removal of heavy metals

The heavy metals like nitrogen and phosphorous due to industrial waste in the sewage can be removed by suitable methods.



Activity 2

Visit a sewage treatment plant in your town and submit a report.

Screen for debris removal

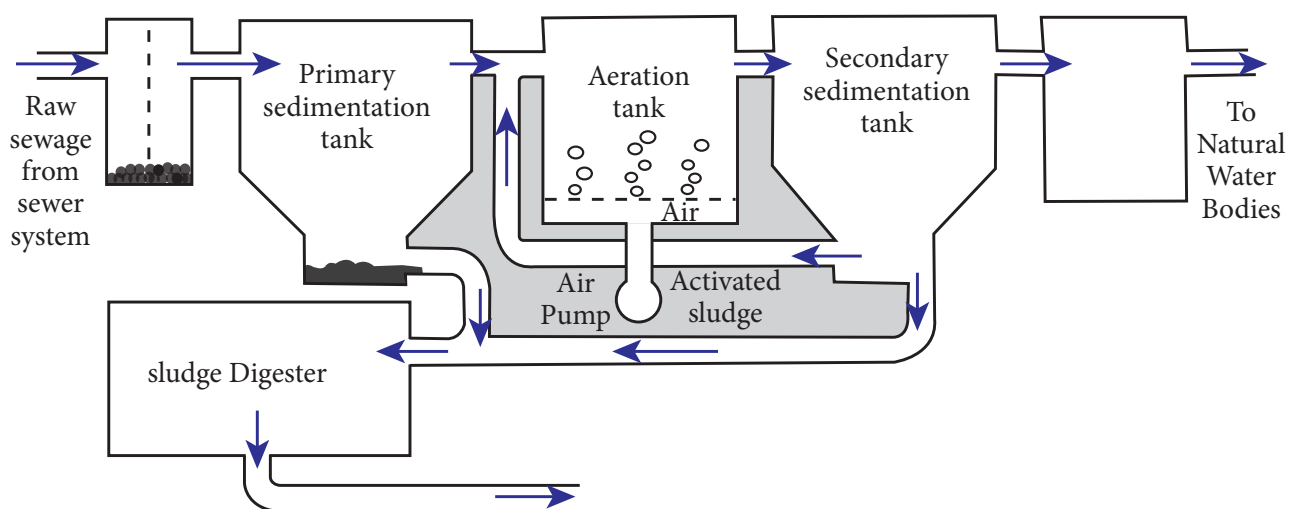

Secondary Sewage Treatment

5.7 Septic Tank

Septic tank is a rectangular water tight under-ground masonry tank. The sewage is admitted into it for treatment. It is suitable for disposing the sewage from isolated buildings, institutions, hospitals, hotels, etc.

5.7.1 Construction and Working of Septic tank

There are two stages of purification in septic tank. They are,

1. Anaerobic digestion
2. Aerobic Oxidation

Construction Details

1. The tank is rectangular in plan and the length is usually 2 to 4 times the breadth, Normally thrice.
2. Liquid depth of 1 to 2 m and free-board of 0.3 to 0.45 m are provided.
3. An elbow pipe (or) 'T' shaped pipe submerged to a depth of 150 to 225 mm below the liquid level is provided as inlet pipe.
4. T shaped outlet pipe is provided to a depth of 150 mm below the liquid level.
5. Inlet baffle is placed at 1/5th the length of tank from the inlet pipe. In larger tank, the baffle walls are constructed to guide the flow and prevent short circuiting.
6. The tank is divided into two compartments. The first one serves as the stilling compartment and the second one serves as the settling compartment with a smooth exit of settled sewage.
7. The floor is provided with all sides sloping (1 in 7) towards one point to facilitate desludging operation.
8. R.C.C roof slab with a manhole cover in each compartment is provided to permit inspection and maintenance.
9. Ventilation is provided by a pipe 40 to 50 mm in diameter. It is taken well above the roof level.
10. A cowl is provided at the top of the vent pipe. It prevents the birds from nesting.

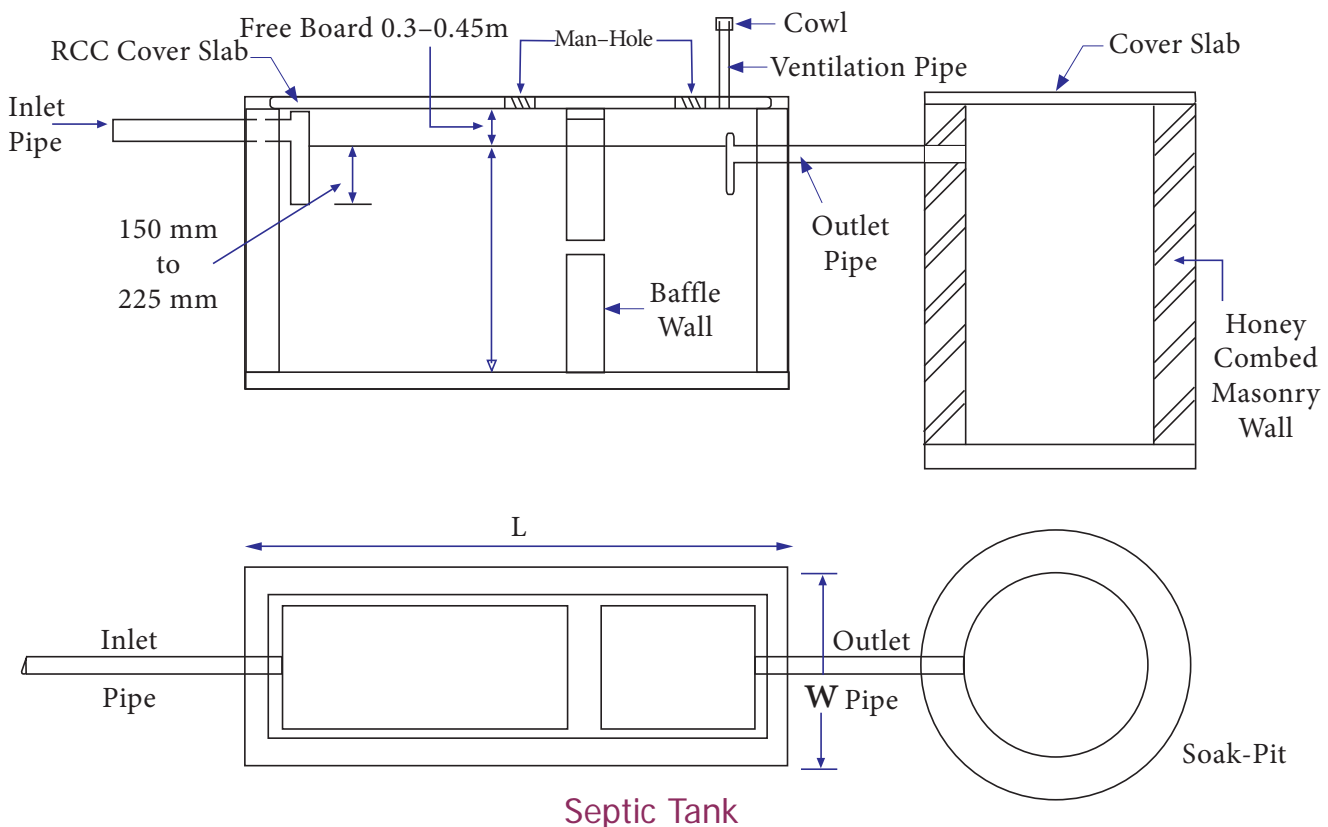



Activity 3

Prepare a report on various steps involved in construction of a septic tank with pictures

Operation and Maintenance

The use of soap water and disinfectants such as phenol should be avoided. They are injurious to the bacterial flora in the septic tank.

The undue accumulation of sludge reduces the capacity of the septic tank and interferes with its proper working. Therefore the contents of the septic tank should be removed periodically. The cleaning period may vary from 6 months to 3 years. In any case it should not exceed 3 years.

Newly built septic tanks are first filled with water up to the outlet level and then seeded with digested sludge to carryout decomposition process.

Soak Pit

Soak pit is a covered circular or square pit. Generally the effluent from septic tank is not disposed off directly on land. For that the effluents are allowed into the soak pit and gets soaked or absorbed into the surrounding soil.

5.8. Sludge Disposal

Sludge

Sludge is the solid matter which is retained from sewage in both primary and secondary treatment units.

The sludge is hygienically unsafe. It contains pathogens and decomposes rapidly. It serves as food for saprophytic organisms. During decomposition it gives offensive odours. Therefore the sludge should be disposed off as early as possible.

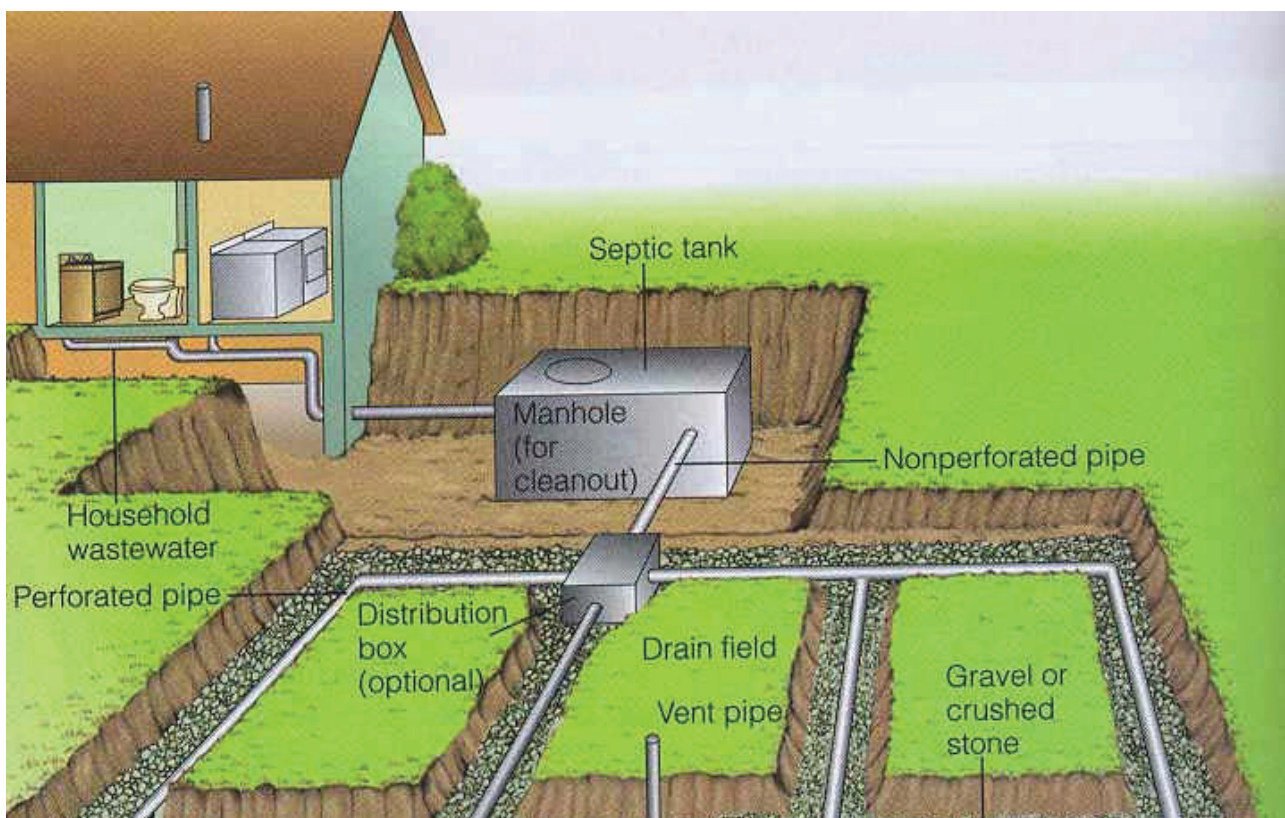

Flow Diagram of Sewage disposal

5.8.1 Quality of Sludge

The quality of sludge produced depends on several factors such as the characteristics of sewage, methods of treatment, temperature, methods of sludge collection, etc.

The quality of sewage can be found out if the following three factors are known



Sludge treatment and disposal



Sewage Sludge Disposal

1. Amount of suspended solids in the incoming sewage
2. Moisture content of the sludge
3. Settlement which is likely to occur in treatment units

5.8.2 Methods of sludge disposal

The various methods of sludge disposal are as follows:

1. Disposal on land
2. Distribution by pipelines
3. Drying on dry beds
4. Dumping into the sea
5. Heat drying
6. Incineration
7. Lagooning (or) Ponding

1. Disposal on land

Sludge can be disposed on land in two ways. They are:

- a. Ploughing
- b. Trenching

2. Distribution by pipelines

In this method, the sludge is conveyed through pipelines to the nearby farm. It is used as fertilizer by mixing with irrigation water. This method is not common in use.

3. Drying on dry beds

In this method the sludge is dried by spreading over the drying beds. It is ideally suitable for tropical country like India.

5.9. Solid Waste Management

5.9.1 Solid wastes

Solid wastes include unwanted and discarded waste materials from houses, hospitals, street sweepings, commercial, industrial and agricultural operations and other types arising from main activities.

In cities they are called refuse and in country side they are named as litter. However they are referred as solid wastes.

Constituents of Solid wastes

The constituents of average solid waste is as below:

| Waste material | percentage |
|--|------------|
| Paper | 31.35% |
| Glass | 9.7% |
| Metals | 9.5% |
| Plastic | 3.4% |
| Rubber | 2.6% |
| Textiles | 1.4% |
| Wood | 3.7% |
| Food | 17.6% |
| Yarn waste | 19.3% |
| Other inorganic and miscellaneous wastes | 1.5% |
| | 100.0% |

5.9.2 Classification of solid waste

| S.no | Sources of Solid wastes | Types of Solid wastes |
|------|-------------------------|--|
| 1 | Residential area | Food waste, rubbish, ashes, vegetable wastes, etc. |
| 2 | Commercial area | Food wastes, rubbish, ashes, demolition and construction wastes, special types of wastes, occasionally hazardous wastes. |
| 3 | Municipal Area | Same as commercial area. |
| 4 | Industrial Area | Same as commercial area |
| 5 | Open Area | Special Waste, rubbish, etc. |

5.9.3 Disposal of Solid Wastes

The disposal of solid waste is done far away from cities using engineering principles

1. To confine the wastes to the smallest possible area.
2. To reduce them to the lowest practical volume.
3. To prevent them from the attack of rodents and vermins.
4. To plan for the final use of reclaimed land.

5.9.4 Methods of Solid Waste Disposal

The principal methods of solid wastes disposal are

1. Dumping
2. Sanitary land filling
3. Incineration
4. Composing
5. Ploughing in fields
6. Grinding and discharging into sewers
7. Salvaging
8. Fermentation and biological digestion

Activity 4

Submit a report on the method of solid waste disposal in your locality.

5.10 Pollution Control

The four major elements namely land, water, air and living organisms together constitute an environment or ecosystem.

Environment can further be subdivided into

- i. Physical Environment
- ii. Organic (or) Biological Environment

Land, water and air together forms the group of environment called **physical**

environment. The living organisms form another group of environment called **biological environment.**

Pollution control is a process of reducing or eliminating the release of pollutants into the environment. It is regulated by various environmental agencies. These agencies established limits for the discharge of pollutant into the air, water and land.

5.10.1 Land Pollution

Land pollution is caused by solid wastes and chemicals. In large cities disposal of solid wastes, chemical wastes, garbage, plants, dead animals like cattles, dogs, birds, etc., cause land pollution.



Sources of Land pollution

The following are the main sources of land pollution

1. Chemical pollutant
2. Metallic pollutant
3. Industrial effluent
4. Domestic effluent
5. Radioactive pollutant
6. Agricultural wastes
7. Biological agents

Effects of land pollution

1. The radio-active walter from Nuclear reactors affects brain and disorders of genetics.
2. Toxic organic compounds from industries affects the fertility of land.
3. Metallic pollutants decrease the soil fertility.
4. Agricultural wastes such as pesticides and fertilizers affects kidney, skin and also causes lung diseases.

Prevention of Land pollution

1. Solid wastes should be treated by pyrolysis method.
2. Suitable techniques can be used for treatment of disposed chemicals from industries pollute the ground water.
3. Solid wastes should be burned and used as fuels.
4. Avoid usage of pesticides and chemical fertilizers.

5.10.2 Water Pollution

Water is said to be polluted, when it contains infective and parasitic agents, poisonous chemical substances, industrial or other wastes (or) sewage.

Types of Water Pollution

The two types of water pollution are as follows,

- a. Natural Pollution
- b. Artificial (or) Manmade pollution

a. Natural Water Pollution

1. It is caused by the adverse weather conditions.
2. Storm water bringing surface wastes, silt, vegetable matter, minerals, bacteria, etc., with it thereby polluting water.
3. Storm reservoir containing sand, silt and hence polluting the water.
4. Properties of ground surface through which the water travels.
5. Natural water pollution is occasional and its consequential effects are little.

b. Artificial water pollution

It is caused as a result of man-made activities as below

1. Wastes from the human habitation such as human excreta, urine, washing, kitchen waste and laundry waste.
2. Wastes from industries such as grease, oil, explosives and radioactive substances, chemicals, alkalis, acids, lime, starch, highly odorous substances, coal washings, vegetable oils and soap, paper pulp, etc.
3. Agricultural wastes like backyard drainage, pesticides, manure, etc.
4. Infiltration of surrounding substances into the water distribution pipes through cracks or leaky joints.



Effects of Water Pollution

1. The self purification property of rivers is lost due to excessive organic load.
2. The fish and other aquatic life are destroyed due to de-oxygenation.
3. Insanitation is caused by suspended solids.
4. The pathogenic bacterias enter into the water due to the presence of organic matter.
5. Foul smelling due to the decomposed floating matter
6. Sporadic outbreak of waterborne diseases due to the consumption of polluted water by communities.
7. River pollution makes the water aesthetically unfit for bathing and other recreational purposes.
8. It is very costly and difficult to treat polluted water.

Preventive measures to control water pollution

The preventive measures to be taken effectively to control water pollution are as follows

1. The people should be educated to avoid water pollution.
2. The industrial wastes should be treated well before discharging them into natural water bodies.

3. Strict rules and regulations should be enforced for the prevention of water pollution.
4. Scientific techniques should be adopted for the environmental control of catchment areas of streams and rivers.
5. Forests should be conserved as they naturally controlling water pollution.
6. Discharging any type of wastes, treated or un-treated into natural water bodies should be avoided.
7. Effluent treatment funds should be raised for the construction and development of treatment plants for all kinds of wastes.
8. The local authority and management of various industries should jointly share the responsibility to assure an effective water pollution control.

5.10.3 Air Pollution

The presence of harmful elements in the atmosphere which affects human health is called air pollution.

Sources of Air Pollution

The main substances of air pollution are as follows

1. Natural sources
2. Manmade sources

1. Natural Sources

Hydrogen sulphide from volcanic disturbances, sulphur dioxide and hydrogen sulphide from seepage of sewage water, salt particles from sea water, air borne particles from soil and vegetation, etc., are the natural sources of air pollution.

2. Manmade sources

These are broadly classified into the following four categories

1. Industrial processes
2. Combustion
3. Motor vehicles
4. Miscellaneous



1. Industrial Processes

Chemical industries, metallurgical industries, oil refineries, fertilizers factories, etc., have contributed their might to air pollution.

2. Combustion

Industrial and domestic combustion of coal, oil and other fuel are another sources of smoke, dust and sulphur dioxide contribute air pollution.

3. Motor Vehicles

Motor vehicles, trucks, ships, trains, aircrafts and other forms of transports contribute air pollution. They emit hydrocarbons, carbon-monoxide, lead, nitrogen oxides.

4. Miscellaneous

Burning of refuse, agricultural activities like crop spraying, pest control, and nuclear energy projects also contribute air pollution.

Effects of Air Pollution

The effects of air pollution are listed as below

1. Effect on human beings
2. Effect on animals
3. Effect on Plants
4. Effect on materials

Effects on human beings

| S.No. | Pollutant | Effects on human beings |
|-------|--------------------|---|
| 1 | Carbon monoxide | Headache and nausea |
| 2 | Nitrogen compounds | Severely irritating and excess illness |
| 3 | Photo chemical | Asthma, eye irritation |
| 4 | Ozone | Headache, irritation of nose and throat |
| 5 | Sulphur dioxide | Respiratory diseases |

Effects on animals

| S.No. | Pollutant | Effects on animals |
|-------|-------------------------|--|
| 1 | Hydrogen sulphide | Respiratory, digestive and pulmonary diseases |
| 2 | Fog and smog | Respiratory diseases |
| 3 | Ozone | Pulmonary disease |
| 4 | Photo chemical oxidants | Skin troubles, cancer and tumour |
| 5 | Fluoride | Diarrhoea, loss of weight, affects fertility, etc. |

Effects on Plants

| S.No. | Pollutant | Effects |
|-------|-------------------------|---|
| 1 | Ozone | Affects growth of tobacco plant |
| 2 | Ethylene | Affects orchids |
| 3 | Photo chemical oxidants | Affects Tobacco plant |
| 4 | Fluoride | Affects Tobacco and gladiola plants |
| 5 | Smoke, smog, fog | Affect forests |
| 6 | Sulphur dioxide | Dangerous and causes great damages to plant |

Effects on Materials

| S.No. | Material | Pollutant | Effects on materials |
|-------|-------------------------------|-----------------------------------|--|
| 1 | Building material | So ₂ , acid gases, etc | Discolouration due to moisture |
| 2 | Metals | So ₂ , acid gases, etc | Tarnishing surface due to moisture and temperature |
| 3 | Paints | So ₂ , H ₂ | Discolouration due to moisture and fungus |
| 4 | Ceramics | So ₂ , acid gases | Discolouration due to moisture |
| 5 | Rubber | Oxidants | Crackling due to sunlight |
| 6 | Electric and electronic parts | Air borne, ozone | Degradation due to wind |

Prevention and Control of Air Pollution

The control of air pollution is ultimately an engineering problem. The World Health Organisation (WHO) recommended the following procedures for the prevention and control of air pollution.

1. Containment

The prevention of escape of toxic substances into the ambient air containment can be achieved by a variety of engineering methods such as enclosures, ventilation and cleaning.

2. Replacement

Replacing the technological process causing air pollution by a new process that does not cause air pollution. Increased use of electricity and natural gas in place of coal is a new process of replacement.

3. Pollution dilution

It is a dilution within the self-cleaning capacity of the environment. Some air pollutants are readily diluted by vegetation. The establishment of green belts between industrial and residential area is a method of dilution. The dilution becomes very difficult when the atmosphere is overburdened with pollutants.



MODEL QUESTION



Part – I (1 Mark)

Choose the Correct answer (1 Mark)

- The liquid wastes from bathrooms, kitchen, wash basin is _____
 a) Sewage
 b) Sullage
 c) Storm water
 d) all the above
- The pipe line through which the sewage is conveyed _____
 a) Pipe
 b) Conduit
 c) Sewer
 d) none of the above
- The collection and conveyance of sewage from multistoried building is in _____ system of sanitation
 a) Water carriage system
 b) conservancy system
 c) one pipe system
 d) two pipe system
- Normal flow of water during rainy season of the year is _____
 a) Wet weather flow
 b) Dry weather flow
 c) sludge
 d) sullage
- The treatment process by which the pathogenic bacteria can be removed by adding chlorine is _____
 a. Disinfection
 b. Activated sludge
 c. Aerobic process
 d. Anaerobic process

Part II

Answer in one or two sentences (3 Marks)

- What is the purpose of sanitation?
- List the shapes of Sewer sections.
- What do you mean by sewer appurtenances?
- Define activated sludge process.
- How water gets polluted?

Part - III

Answer in brief (5 Marks)

- Write briefly about the systems of sanitation
- Write the merits and demerits of water carriage system
- List the methods of solid waste disposal

Part - IV

Answer in detail (10 Marks)

- Explain the various tests carried out for a newly laid sewer line
- With a neat sketch, Explain the construction of a septic tank
- Explain in detail the causes, effects and preventive measures of air pollution.

Answers: 1) b 2) c 3) a 4) a 5) a

Answers:

UNIT 6

HIGHWAY ENGINEERING



“ A bend in the road is not the end of the road...
Unless you fail to make the turn.”

-Helen Keller



Table of Contents

6.1 Introduction

- 6.1.1 Definition
- 6.1.2 Characteristics of road transport
- 6.1.3 Uses of Roads

6.2 Highway Development and Planning

- 6.2.1 Highway Development in India
- 6.2.2 Necessity of Highway Planning
- 6.2.3 Classification of Roads

6.3 Geometrical Design of Highways

- 6.3.1 Road Structure
- 6.3.2 Width of Road
- 6.3.3 Right of Way
- 6.3.4 Highway cross-section elements

6.4 Highway Materials

- 6.4.1 Types of Road Aggregates
- 6.4.2 Requirement of a good road aggregate
- 6.4.3 Test for road materials

6.5 Highway Construction

- 6.5.1 Types of Highway Construction

6.6 Soil Stabilization

- 6.6.1 Purpose of Soil Stabilization
- 6.6.2 Methods of Soil Stabilization

6.7 Road Signals

- 6.7.1 Objectives of Road signals
- 6.7.2 Requirements of Road signals
- 6.7.3 Types of signals

6.8 Road Signs

- 6.8.1 Purpose of Road signs
- 6.8.2 Types of Road signs

6.9 Road Accidents

- 6.9.1 Causes of Road Accidents
- 6.9.2 Effects of Road Accidents
- 6.9.3 Prevention of Road Accidents

6.10 Road Side Developments

- 6.10.1 Road Arboriculture
- 6.10.2 Highway Lighting

Learning Objectives

At the end of this lesson you shall be able to

- Understand the history of Highway Development in India
- List the classification of Roads
- Know the various geometrical designs used in Highways
- State the various types highway materials
- List the tests to be conducted on various road materials
- Explain the different types of Road construction
- Understand the purpose and methods of soil stabilization
- List the types of Road Signals and Road Signs
- Explain the causes and prevention of Road accidents
- Define Road Arboriculture and its uses
- Have an idea of Highway Lighting and its benefits

6.1 Introduction

Transportation is the movement of human, animals and goods from one place to another. The most common modes of transport are air, water and land transport. Other modes include pipelines, cable transport and space transport. Transportation plays an important role in the country's economic, industrial, social and cultural development.

6.1.1 Definition

Highway Engineering deals with the design, location, methods of construction and maintenance of all types of roads in plain country as well as in hilly areas.



6.1.2 Characteristics of road transport

1. Roads can be used for all types of vehicles like cars, buses, trucks, etc.,
2. Road transport requires a relatively small investment and maintenance cost when compared to other modes of transportation.
3. It offers flexibility of change in direction, location, speed and timings of travel.
4. It saves time for short distance travel.
5. Road transport is easily available to the public.

6.1.3 Uses of roads

1. They are important for country's overall development and economic prosperity.
2. A good network of roads helps in the defence of a country during war and peace time.
3. Better law and order can be maintained.

4. Roads serve as a feeder lines and help in the development of other means of communication.
5. They facilitate communication on land.
6. Natural resources of an area can be tapped and improved.
7. Roads help to increase the land value enroute.
8. Roads aid good medical facilities to reach everyone.
9. They provide good commercial links between cities.
10. The improvement of highway system increases the mail facilities.

6.2 Highway Development and Planning

6.2.1 Highway Development in India

Roads in Ancient India

The excavation of Mohenjo-daro and Harappa have exposed the existence of roads in India even 3500 years B.C. Kautilya, the first prime minister of Emperor Chandra Gupta Maurya, wrote a book 'Artha Shastra'. In that book he mentioned the specifications for road width, road surfaces, traffic control, etc. King Ashoka constructed a good network of roads during 269 B.C., where trees were planted on either side of the roads for giving shade to the travellers and the rest houses were provided at a distance of about 5 – 7 km along the road for the comfort and convenience of the tired travellers.

Roads in Mughal Period

During Mughal period, the Muslim rulers improved the roads of India to a great extent which received high appreciation

from the foreign visitors who visited India at that period. 24 long roads connecting distant towns and cities were constructed during Mughal period.

Roads during British rule

In 1865 Lord Dalhousie, the Governor-General formed the Public Works Department in more or less the same format that exists today.

Jayakar Committee

Jayakar Committee was formed in 1927 to investigate and report about the existing roads and the road development in the country. A central road organisation was set up in 1930 and in 1935 a transport committee was formed.

Nagpur Plan

After 2nd World War, a conference of all the chief engineers of all the states and Provinces was convened by the central government on 15th December, 1943 at Nagpur on the recommendation of I.R.C. This was the first attempt to prepare a co-ordinated road development programme in a planned manner. This conference prepared the first 20-year road development plan and was popularly known as Nagpur plan. It drew the following conclusions:

1. To recommend an all Indian basis for geometric standards, highways and bridge specifications, road machinery and road organisations.
2. To classify all roads as National highways, State highways, District roads and Village roads.
3. To implement a balanced development of all classes of roads.
4. The Central government to take up the complete financial responsibility of all major roads.
5. The state government to take up the complete financial responsibility of all other roads.



Golden Quadrilateral

It is a network of highways that connect the four major metropolitan cities of the country in the four directions – Delhi (North), Chennai (South), Kolkata (East) and Mumbai (West) – thus forming a quadrilateral and hence the name “Golden Quadrilateral”. The project was launched in 2001 and put into operation in January 2012. The Golden Quadrilateral project included construction of new express highways, including renovation and extension of the existing highways to four or six lanes.

Major highlights of the Golden Quadrilateral

- It is the largest highway project completed in India.
- It is the fifth longest highway project in the world.

- The overall length of the Golden quadrilateral is 5,646km.
- The Golden Quadrilateral passes through 13 states of India.
- It constitutes only the national highways of the country and not state highways and rural-urban roadways.
- The project cost was ₹. 60,000 crores.

The Golden Quadrilateral project provides faster transport networks between major cities and ports. It provides smoother movement of goods and people within India. It enables industrial development and job development in smaller towns through access to markets. Farmers are able to transport their produce through better transportation. It has enormously increased the economic growth of the country.

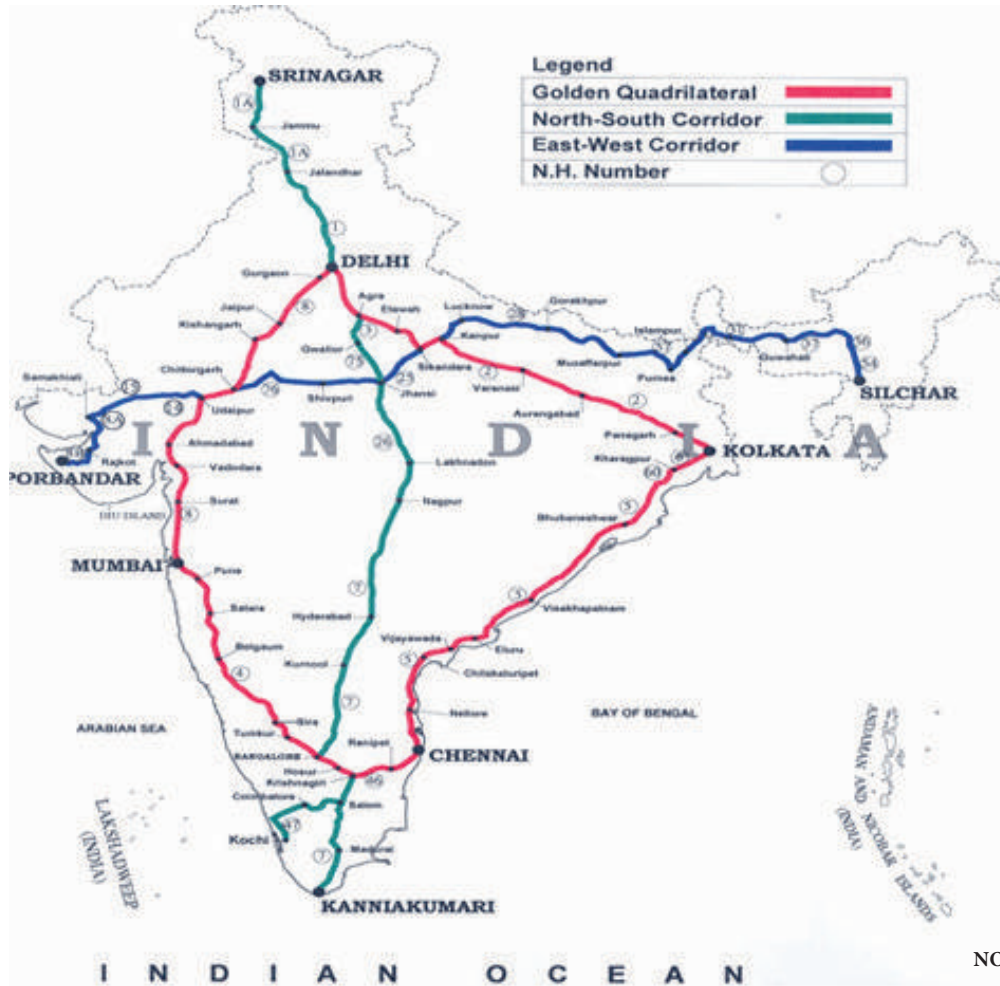

DO YOU KNOW?

Longest Expressway in India

Yamuna Expressway is one of India's longest six-lane (extendable to 8 lanes), 165 km long, controlled-access expressway. The expressway starts from Greater Noida and ends at Kuberpur on NH2 towards Kanpur and Agra. In addition, a total of 13 service roads of about 168 km have been built for local commuters to access the expressway. The total project cost was ₹128.39 billion.

North South corridor and East West corridor road project

The **North-South-East-West Corridor (NS-EW)** is the largest highway project by the National Highways Development Project (NHDP) in India. The length extends to 7,142 km with 4/6 lane North-South corridor (Srinagar to Kanyakumari) and East-West Corridor (Silcharin to Porbandar) comprising national highways connecting four extreme points of our country.

6.2.2 Necessity of Highway Planning

Following are the necessities of highway planning

- i. To assist the general planner about transportation demand.

- ii. To create awareness of unforeseen events, conditions, developments, etc.
- iii. To establish financial and management policies required to implement sound decisions.
- iv. To make optimum use of the existing conditions towards improvement.
- v. To carry out efficient and safe traffic operations in highways.
- vi. To provide factual analysis leading to the determination of required physical development.

6.2.3 Classification of Roads

i. Classification according to location and function

- a. National Highways
- b. State Highways
- c. Major district roads
- d. Other district roads
- e. Village roads

a. National Highways (NH)

These are major roads connecting major ports, foreign highways, capitals of states, etc. National highways should have at least two lanes and be structurally strong and have best surface. The central government providing financial assistance for the construction of roads and maintenance is done by the state governments.

b. State Highways (SH)

These are major roads within a state connecting district head quarters and important cities between themselves. Also, it connects points in the national

highways and other state highways. They should be preferably of two lanes.

c. Major District roads (MDR)

District roads are constructed and maintained by corporation or municipality. These are the roads between district headquarters, commercial centres and other important places within the district. They establish connection with National, State highways and rail terminals.

d. Other District roads (ODR)

These roads connect important rural areas of production and market places with major district roads and state highways.

e. Village roads (VR)

These roads connect villages with one another and with nearby cities. These are constructed and maintained by respective union offices.

ii. Classification based on the material used for road construction

1. Earthen road
2. Gravel road
3. Water Bound Macadam road
4. Bituminous road
5. Asphalt road
6. Cement Concrete road

6.3 Geometrical Design of Highways

The geometric design of a highway deals with the dimensions and layout of various features of the highway such as

alignment, cross section elements, sight distances and intersections.

The geometrics of highway should be designed to provide optimum efficiency in traffic operations with maximum safety at reasonable cost.

6.3.1 Road Structure

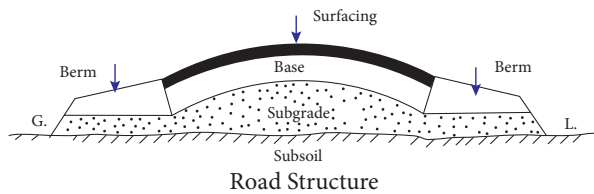

- 1. Subgrade:** It is the natural foundation on which the entire road structure rests. The life of road depends primarily on stable and dry subgrade.
- 2. Formation:** It is the top surface of the subgrade.
- 3. Sub-base:** It is the course laid between the base course and subgrade. It is used only when the bearing capacity of subgrade is poor or when the subgrade has poor drainage properties.
- 4. Base course:** It is the structural foundation of the road. It is also termed as soling. The function of a road base is to transmit load of traffic from the surfacing to the subgrade. It should possess structural stability and should be of sufficient thickness to develop a good bond with the surfacing.
- 5. Wearing course:** The topmost layer on which the traffic directly travels is known as wearing course. The road surfacing will provide a smooth and stable running surface. The surfacing should be impervious and should protect the base and the subgrade from the action of weather and rain water.

6.3.2 Width of Road

The width of pavement or carriage way depends on the width of traffic lane and number of lanes. The carriage way intended for one line of traffic movement may be called as a **traffic lane**. The lane width is determined on the basis of the width of vehicle and the minimum side clearance provided for the safety. When the side clearance is increased there is an increase in speed of the vehicles and hence increase in the capacity of the pavement. A width of 3.75 m is considered desirable for a road having single lane for vehicles of maximum width 2.44 m. For pavement having two or more lanes, width of 3.5 m per lane is sufficient.

6.3.3 Right of Way

Right of way is the area of land acquired and reserved along its alignment for construction and development of a highway.

6.3.4 Highway Cross Section Elements

i. Camber Or Cross Slope Or Cross Fall

The cross-section of a road surface shows the convexity upwards and the highest point on the curved surface is known as crown.

Camber is defined as the slope of the line joining the crown and the edge of the road surface.

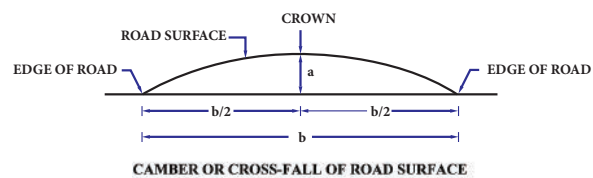

(a) IRC Recommendations for Road Camber

| Sl. No. | Type of surface | Areas with greater than 100cm annual rainfall | Areas with less than 100cm annual rainfall |
|---------|--------------------------------|---|--|
| 1 | Earth, gravel, stabilised soil | 1 in 16 | 1 in 24 |
| 2 | Water bound macadam | 1 in 36 | 1 in 46 |
| 3 | Bituminous surfacing | 1 in 60 | 1 in 60 |
| 4 | Cement Concrete roads | 1 in 72 | 1 in 72 |

(b) Types of Camber

| | | | | |
|---------------------|--------------------|----------------------|------------------------|--|
| 1. Sloped camber: | i) Straight camber | ii) Multiple camber | | |
| 2. Curved Camber: | i) Barrel camber | ii) Parabolic camber | iii) Elliptical camber | |
| 3. Composite camber | | | | |

(c) Uses of Camber

1. Provides surface drainage of rainwater.
2. Prevents the entry of water or moisture into the subgrade soil thereby increasing the durability of the road.
3. Easy separation of up and down traffic.

ii. Super Elevation

On horizontal curves, there is a tendency for the vehicles to fall away from the outer portion of the curve due to the existence of centrifugal force. To overcome this effect, the outer edge of the road is raised with respect to the inner edge. It is called as **super elevation**.

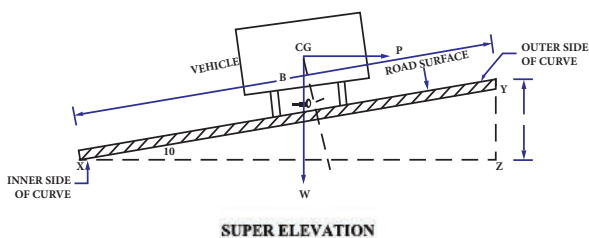
**(a) Advantages of Super elevation**

- i. It increases the stability of fast-moving vehicles on horizontal curves.
- ii. It counteracts the effect of centrifugal force.
- iii. On super elevated curves, the vehicles need not be slowed down.
- iv. The water can be drained off easily, therefore there is no possibility of formation of pot holes on the outer edge.
- v. It minimises the danger of skidding or toppling of fast-moving vehicles.

iii. Sight Distance

It is the distance along the centre line of the road over which a driver can see the opposite vehicle on the road surface in order to avoid accident.

This distance should be such that the drivers and pedestrians are given sufficient time to react and not only to

avoid accident but also to extent mutual road courtesy.

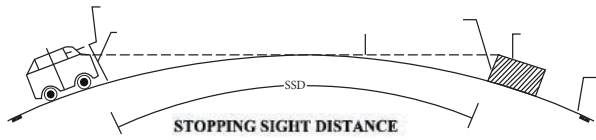

(a) Types of Sight Distances

- i. Crossing sight distance
- ii. Non-passing sight distance
- iii. Passing sight distance
- iv. Lateral sight distance

iv. Road Gradient

It is the rate of rise or fall of the road along its alignment. It is expressed as the ratio of difference in height of its extremes to the horizontal length between them.

$$\text{Road gradient} = \frac{\text{Difference in Height}}{\text{Horizontal Length}}$$

(a) Factors affecting gradient

- i. Topography of the country
- ii. Characteristics of the traffic
- iii. Rainfall in the locality
- iv. Drainage
- v. Safety

(b) Types of gradient

- i. Maximum gradient
- ii. Minimum gradient
- iii. Average gradient
- iv. Ruling gradient
- v. Exceptional gradient
- vi. Floating gradient

v. Road Curves

Road curves are regular bends in roads to bring a gradual change in direction.



(a) Classification of road curves

In general, there are two types of curves, they are

- i) Horizontal Curves
- ii) Vertical curves

Horizontal Curves: It is a curve in plain provided to change the direction of alignment. Horizontal curves are of different types as follows

- Simple circular curve
- Compound curve
- Reverse curve
- Transition curve
- Spiral
- Lemniscate

Vertical Curves: It is a curve in elevation provided at change of gradients. Vertical curves are of two types, namely

- Summit curve or crest curve
- Valley curve or sag curve

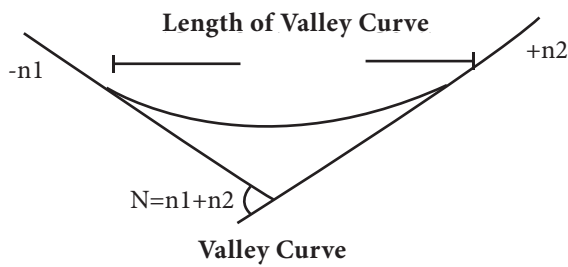
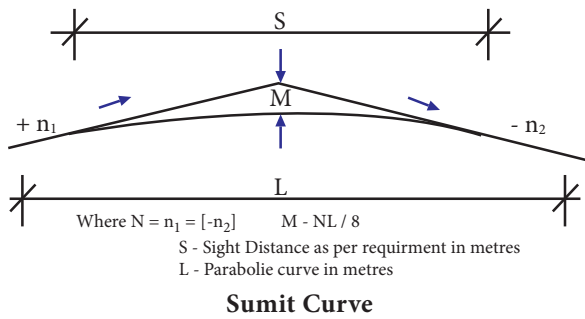

6.4 Highway Materials

The materials required for the construction of highways can be broadly divided into the following two categories.

1. Aggregates
2. Binding materials. (Example: Bituminous materials, cement)

6.4.1 Types of Road Aggregate

The road aggregates can be classified in the following categories.

- i. Crushed rock aggregates
- ii. Gravel
- iii. Sand
- iv. Blast furnace slag



Activity 1

Collect the pictures of various types of road materials and prepare an album.

6.4.2 Requirement of a good road aggregate

Following are the desirable properties or requirements of a good road aggregate.

- i. Strength
- ii. Hardness
- iii. Toughness
- iv. Durability
- v. Shape
- vi. Adhesion with bitumen

6.4.3 Test For Road Materials

i) List of tests on sub grade soil

- i. Shear tests
- ii. Bearing tests
- iii. Penetration tests

ii) List of tests on road aggregates

- i. Water absorption test
- ii. Aggregate crushing test
- iii. Aggregate impact test
- iv. Attrition test

iii) List of tests in Bituminous material

- i. Ductility test
- ii. Loss on heat test
- iii. Float test
- iv. Penetration test
- v. Softening point test
- vi. Solubility test
- vii. Specific gravity test

6.5 Highway Construction

6.5.1 Types of Highway Construction

1. Earthen Road
2. Gravel Road
3. Water Bound Macadam Road
4. Bituminous Road
5. Cement Concrete Road

1. Construction of Earthen Road

It is the cheapest type of road in construction because it is made from the natural soil available at the site. It provides a link for very light traffic.

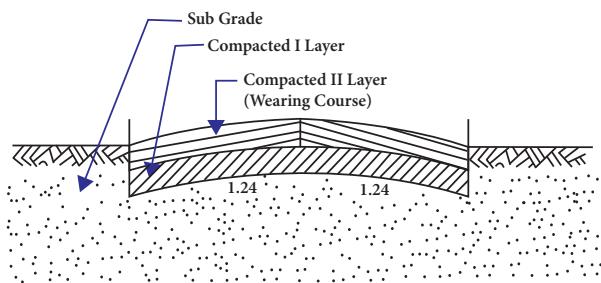

CROSS SECTION OF EARTH ROAD

Construction

1. The centre line is fixed and reference pegs are driven for the guidance of vertical profile of road.
2. The ground is cleared by removing all vegetation.
3. The subgrade is prepared and it is provided with necessary camber (1 in 24) and longitudinal gradient.
4. The subgrade is properly compacted by rolling.
5. A layer of 10cm graded soil is spread evenly and rolled at optimum moisture content with sheep foot rollers.

6. If required, another soil layer of 10cm thick is also spread and rolled properly to act as wearing course.
7. The surface is water cured for 4 or 5 days without traffic.
8. The compacted earthen road is allowed to dry for a period of about 5 to 10 days before opening it to traffic.



Maintenance of Earthen Road

Proper and constant maintenance is required to keep these roads in service. Hence, periodic repairs to pot holes and ruts are essential which are filled with earth and compacted by hand rammers. Side drains are also properly maintained as the life and efficiency of the earthen roads mainly depend on the efficient drainage system.

2. Construction of Gravel Road

Gravel roads are considered superior to earthen roads as they can carry heavier traffic. These roads are constructed with well graded quality gravel obtainable from river beds or by crushing the stones. The various methods of construction of gravel road are

- i. Trench spread method
- ii. Feather edge spread method

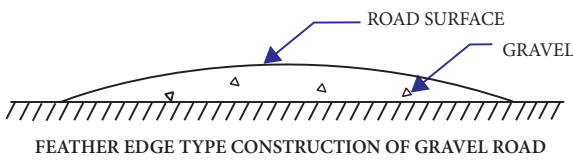
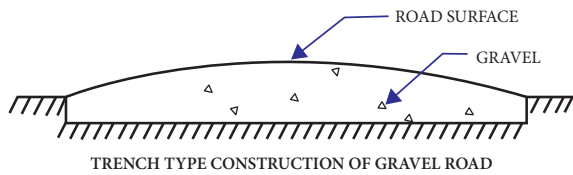

Construction

1. The subgrade is prepared to proper gradient, camber and compacted well.
2. On the prepared subgrade, a mixture of gravel, earth and sand are spread to the required thickness.
3. The compacted depth of gravel roads is generally 200mm. It is obtained in two layers, each of compacted thickness of about 100mm.
4. The layer is rolled by using smooth wheeled light rollers starting from the edges and proceeding towards the centre.
5. During rolling, proper gradient and camber are maintained and sufficient care is to be taken to see that no pebbles get crushed under the roller.
6. The camber is checked at regular intervals and it is corrected if necessary.
7. A thin layer of sand of about 5mm to 10mm thickness is provided before opening the road to traffic.



3. Construction of Water Bound Macadam Road

Construction

The W.B.M. road is constructed in the following stages

1. Subgrade
2. Sub-base
3. Base
4. Wearing course
5. Providing berms
6. Opening for traffic

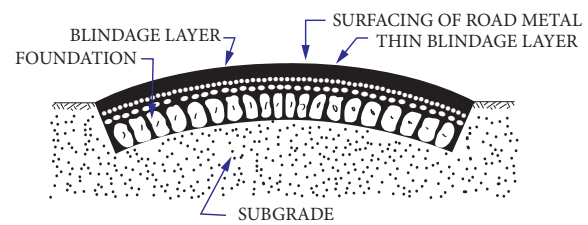

WATERBOUND MACADAM ROAD

1. Subgrade and kerbs

The subgrade is prepared to the required grade and camber by filling up the depressions and pot holes. The corrugations are removed by scarifying. Stone kerbs are then provided at the ends of the subgrade.

2. Sub-base

If necessary, the sub-base is prepared with locally available granular materials over the whole width of formation and rolled to the shape of the camber.

3. Base or foundation course

12 to 18mm size boulders or broken stones is spread and hand packed with as little voids as possible. The surface is rolled with 10-ton roller. The rolling should be started from edge of road to the centre.

4. Wearing course

This can be laid in one or two layers, each layer not exceeding

15cm, depending upon the total thickness required. This includes following steps,

- a. Spreading the metal
- b. Rolling dry
- c. Screeding and wet rolling
- d. Topping, watering and rolling
- e. Curing

5. Providing berms

Usually, earthen berms with outward slope are provided. By filling earth by the side of the kerbs the level is raised to the top of road surface.

6. Opening for traffic

After curing the road is opened for traffic.



Defects Of WBM Road

- i. Formation of pot-holes and ruts due to the loss of soil binder by rain water washing.
- ii. Disintegration of road materials caused by the large variation of temperature.
- iii. Damage caused by heavy traffic.
- iv. Excessive tensile stresses induced into the top layer of pavement due to wheel load.

- v. Loosening of surface metal by suction of binder caused by the fast-moving rubber tyred wheels.
- vi. Crushing of road metal due to attrition and impact by steel-tyred wheels.
- vii. Blowing of the crushed and pulverised road metal by wind or by fast moving vehicles.

4. Construction of Bituminous Road

There are number of techniques for the construction of bituminous road. Here we will discuss about surface dressing with single coat.

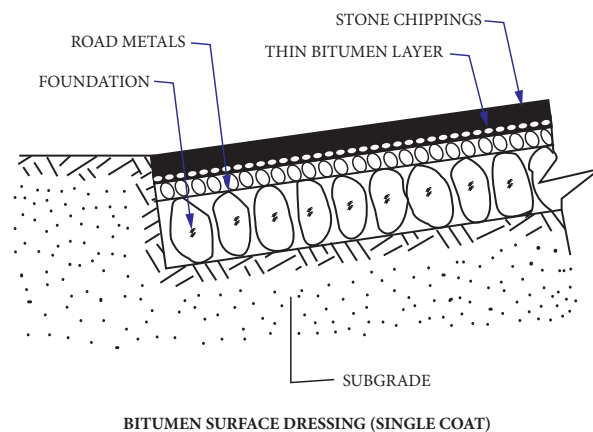

The construction procedure is as follows

1. Preparation of road surface

The road surface is prepared to the required shape of camber by removing all the depressions, pot-holes, ruts, etc.,

2. Application of bitumen

The bitumen is heated to the desired temperature and it is applied uniformly on the prepared road surface at the specific rate.

3. Spreading the stone chippings

The chippings are spread on the surface immediately after the



application of bitumen at the specified rate without accumulation at any particular spot.

4. Rolling

It is then rolled by a medium roller until the chippings are thoroughly embedded in the bitumen. This can be observed when there is no movement of any metal while the roller is moving on the surface.

5. Finishing

The surface is then cleaned and it is checked for its cross profile. A tolerance of 2mm in thickness per metre length is permitted. The road is then opened for traffic after 24 hours.



Methods of Construction of Cement Concrete Roads

- i. Alternative bay method
- ii. Continuous bay method

i. Alternative bay method

In this method, if the roads are of single lane, it is divided into suitable bays of 6m to 8m length and the construction work is carried out in alternate bays as shown in the fig. below.

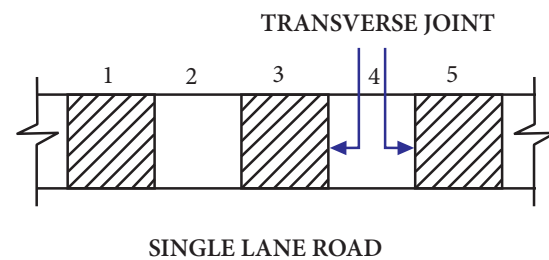

If the roads are of double lane, the construction work is carried out in alternate bays as in fig. below.

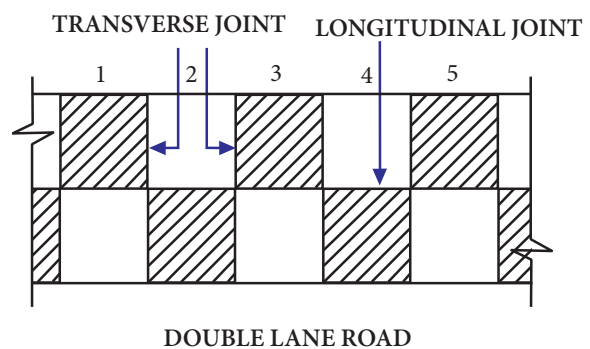

Activity 2

Prepare a report on the stages of road construction in your nearby locality with pictures.

5. Construction of Cement Concrete Road

Concrete road surfacing is superior than other kinds of road surfacing. The cement concrete road provides rigid surface.



The construction of other bays is commenced only after the concrete laid in earlier bays are dried out.

ii. Continuous bay method:

In this method, all the bays 1,2 and 3 are laid continuously without any break and construction joints are provided at the end of the day's work.

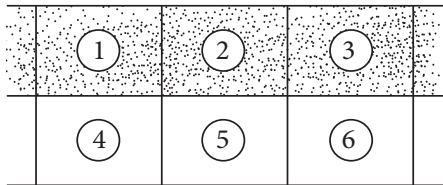

CONTINUOUS CONSTRUCTION METHOD

Construction Procedure for Cement Concrete Roads

Stages of Construction

1. Subgrade preparation
2. Base course preparation
3. Formwork
4. Watering the prepared base
5. Mixing, placing and spreading of concrete
6. Compaction and floating
7. Belting
8. Brooming
9. Checking the finished surface
10. Curing
11. Filling joints and edging



1. Subgrade Preparation

The subgrade is properly compacted and is brought to the required gradient and camber. It is checked by means of a template.

2. Base course preparation

If found necessary, a WBM base course is provided over the subgrade.

3. Formwork

After the base course is completed, formwork for the concrete slab is laid. This may be of steel or timber. It should be equal to the thickness of the slab. It should be oiled and checked for line and grade before concreting.

4. Watering the prepared base

After formwork has been set, the surface of base or subgrade is wetted with as much water as it can readily absorb. The surface should be kept wet for about 12 hours before concreting. The object of watering is to avoid absorption of water from concrete by saturating the subgrade or base.

5. Mixing, placing and spreading of concrete

The concrete should be prepared to the designed water-cement ratio. Then it is placed in the form work to its full width in layers not exceeding 5 cm thick and proceeded lengthwise. The topmost layer should be to the actual profile.

6. Compacting and floating

The compaction and consolidation of concrete may be done by means of hand tampers or mechanical vibrators. The surface is tamped longitudinally, and is finished

by hand floats to produce uniform and even surface.

7. Belting

Belting is done to finish the surface with a canvas or rubber belt. It is applied cross-wise by two persons and moved longitudinally.

8. Brooming

Brooming is done immediately after belting and when concrete is partially set to get rough and gritty surface.

9. Checking the finished surface

The road surface is now checked for desired grade and camber and for evenness with a long wooden straight edge during floating. If the tolerance is more than 2mm per metre the portion of the road should be corrected.

10. Curing

It is carried out for the concrete to harden. The various curing methods are

- a. Use of moist gunny bags
- b. Ponding
- c. Moist sand or earth covering
- d. Use of moist gunny bags for a day and followed by calcium chloride etc.,
- e. Steam curing, membrane covering, painting, etc.,

11. Filling joints and edging

All the joints are to be filled properly with suitable material.

After completion of concrete slab, brick edging or W.B.M. pavement may be provided to protect the edge of the slab.

Merits Of Concrete Roads

The merits of concrete roads are listed below

1. Low maintenance cost.
2. Concrete roads are dustless, smooth and non-slippery.
3. Can be laid on any subgrade.
4. Can easily be reinforced when required.
5. Do not develop corrugations.
6. Last longer if laid properly.
7. Provide a smooth, safe and excellent surface under all conditions.
8. Have better weather resisting qualities.

Demerits Of Concrete Roads

The demerits of concrete roads are listed below.

1. High initial construction cost.
2. Develop cracks due to temperature variation.
3. Construction requires skilled workmanship and supervision.
4. Require time for curing.
5. Glare due to reflection of sunlight may lead to accidents.
6. Cutting of the slab after laying for any purpose is difficult and costly.

6.6 Soil Stabilization

Stabilization is the process on soil to improve its strength or by reducing its vulnerability to the adverse influences of water and traffic.



6.6.1 Purpose of Soil Stabilization

1. To increase shear strength of soil.
2. To increase resistance to softening action of water.
3. To increase the flexibility without deformation and cracking under traffic.
4. To avoid changes in soil characteristics due to increase or decrease of water content.
5. To alter the chemical properties of soil to suit the traffic requirements
6. To reduce shrinkage and swelling due to water content.
7. To increase the compressive strength of soil irrespective of moisture content.

6.6.2 Methods of Soil Stabilization

Following are the various methods of soil stabilization.

1. Bituminous stabilization
2. Cement stabilization
3. Chemical stabilization
4. Complex stabilization
5. Electrical stabilization
6. Grouting stabilization
7. Lime stabilization
6. Mechanical stabilization
9. Thermal stabilization

Activity 3

Form a group and prepare a PowerPoint presentation on any one of the soil stabilization method.

Plastic Man of India.



Dr. Rajagopalan Vasudevan, professor from Madurai's Thiagarajar College of Engineering has discovered an ingenious way to build durable roads using plastic waste into usable form of tar has caught the world's attention, So that civic bodies from other countries have been keen to buy the technology. Instead, he has chosen to share the technology with the Indian government for free.

He first implemented it on the road inside the campus of Thiagarajar College of Engineering. Today, this idea has been adopted by many towns and cities across the country. These include Kovilpatti, Kothamangalam, Madurai, Salem, Wellington, Chennai, Puducherry, Hindpur (Andhra Pradesh), Kolkata, Goa, Shimla, Thiruvananthapuram, Vadakara, Calicut, Jamshedpur and Kochi.

Dr. Vasudevan was honoured with one of India's highest civilian awards, the Padma Shri, for his groundbreaking research on re-using waste plastic in a very unusual way.

6.7 Road Signals

To control the movement of traffic, to regulate and to give caution, the equipment that are operated using electricity emitting various colours of lights are called as signals.

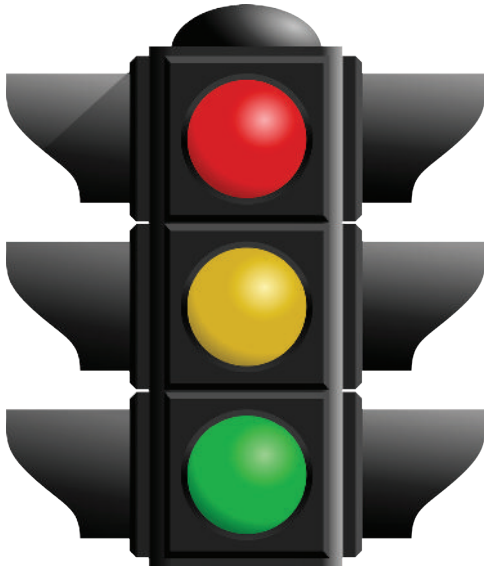

6.7.1 Objectives of Road Signals

The objectives of installing signals are as follows

- i. To control and regulate the movement of traffic in a proper way.
- ii. To control and reduce the speed of vehicles that move through major highways and other secondary highways.
- iii. To coordinate the movement of vehicles that move through or move towards a certain place and to proceed them with certain cautions.
- iv. To stop or halt the continuous movement of traffic for a short period of time in a particular road so as to enable pedestrians and other vehicles in the perpendicular roads to cross safely.
- v. To help and guide the vehicles to choose their respective roads or lanes.

6.7.2 Requirements of Road signals

- i. Various roads that intersect at a particular junction should have atleast minimum number of vehicles and pedestrians utilizing them.
- ii. Heavy traffic zones in important roads where in signals need to be installed for easy negotiation.
- iii. Zones which have large number of intersections are prone for occurrence of accidents. Hence it becomes vital to install signals at the intersections.
- iv. Signals could be also installed on the following specific situations.
 - a. School zones wherein the major number of pedestrians crossing will be children.
 - b. Places where majority of the pedestrians are either blind, aged or physically challenged. Example – Blind school.
 - c. Places where the situation suddenly changes from a village to a city.
 - d. At the starting point where the roads attain steeper gradients.

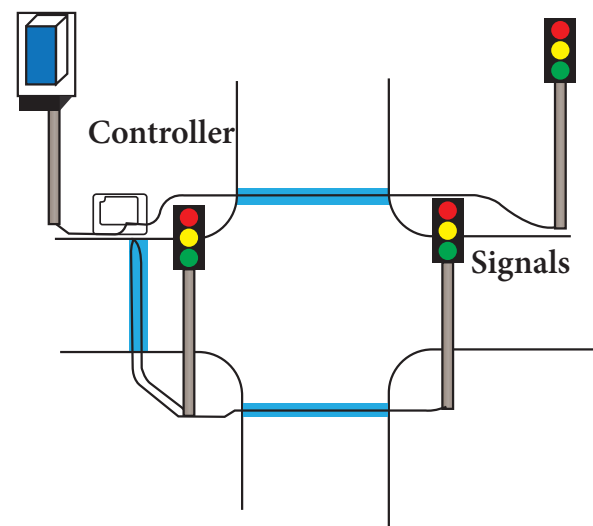



6.8 Road Signs

The road signs or traffic sign is the most commonly used and least costing traffic control device.

6.8.1 Purpose of Road Signs

1. To achieve regular, control and orderly movement of traffic.
2. To reduce the chances of accidents.
3. To cross the road by pedestrians at intersections.
4. To guide drivers about the road conditions ahead.
5. To direct traffic on different routes.

6.7.3 Types of Signals

Signals can be classified as follows

1. Traffic control signals
 - This type may either be
 - i. Fixed time signals
 - ii. Traffic actuated signals
2. Pedestrian signals
3. Special signals

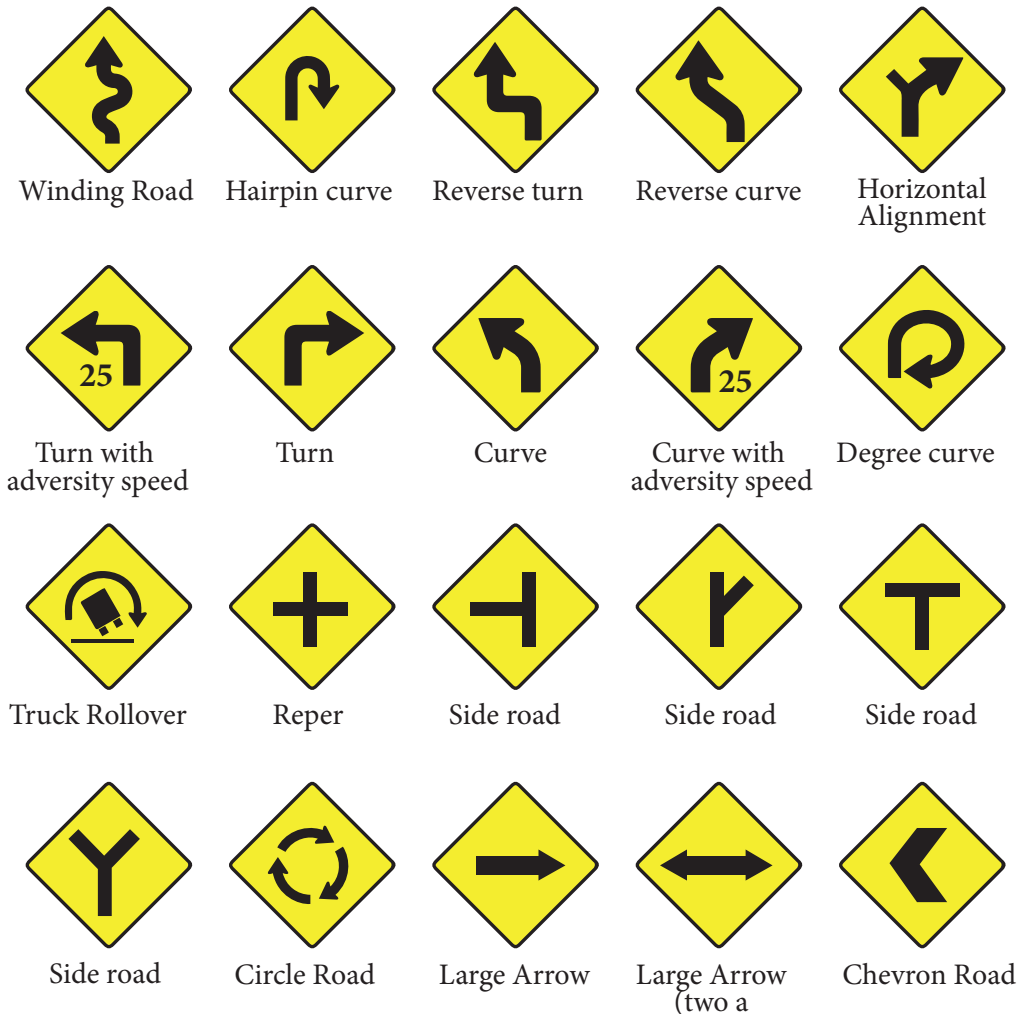

6.8.2 Types of Road Signs

The road signs are classified in the following three categories

- 1) Regulatory or Mandatory signs
- 2) Warning or Cautionary signs
- 3) Guide or Informatory signs

1. Regulatory Signs or Mandatory Signs

These signs are used to inform the road users of certain laws, regulations and prohibitions. The violation of these signals is of legal offence. Some of the regulatory signs are i) Overtaking prohibited, ii) No Parking, iii) Speed Limit, iv) Horn Prohibited, v) Restricted End sign.



2. Warning or Cautionary Signs

These signs are used to warn the road users of certain hazardous conditions that exist on or adjacent to the roadway. The warning signs are in the shape of equilateral triangle with its apex pointing upwards are provided adjacent to the road. Some of the warning signs are i) Right hair pin bend, ii) Ferry, iii) Right side road,

iv) Left side road, v) Narrow bridge, vi) Right reverse bend, vii) Right hand curve, viii) Left hand curve, ix) School, x) Hump or rough road.

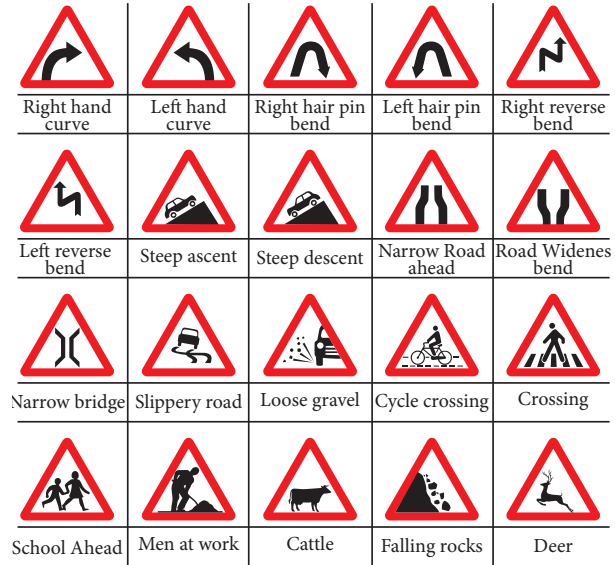

3. Guide or Informatory Signs

These signs are used to provide information and guidance for the road users. These signs also indicate the places and route identifications. Some of the informatory signs are i) First aid post sign, ii) Hospital, etc.

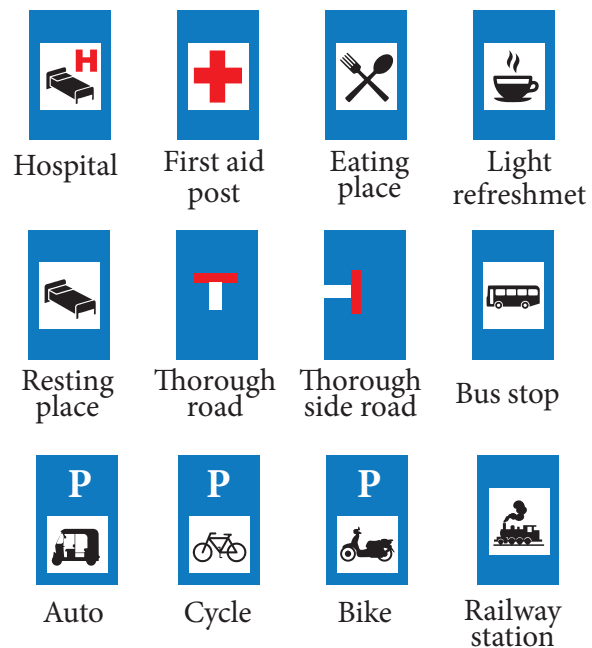

6.9 Road Accidents

Road accidents are certainly the most serious outcome due to defective traffic planning and controlling. The reasons for this are the extremely dense road traffic and the relatively great freedom of movement given to drivers.

In India, road accidents accounted for 480,652 in 2016 which caused 150,785 traffic-related deaths. The three highest total number of fatalities were reported in Uttar Pradesh, Maharashtra and Tamil Nadu. Of which Tamil Nadu records the highest road accidents for a decade and its capital Chennai has more accidents than any other city in India. The World Health Organization (WHO) identified the major causes of traffic accidents as driving over the speed limit, driving under the influence, failure to maintain lane and not using helmets and seat belts.



6.9.1 Causes of Road Accidents

Road accidents are caused due to the following reasons

1. Intake of alcohol by driver.
2. Use of mobile phones by the driver during driving and by pedestrians during crossing the road.
3. Driving at overspeed.

4. Violating the traffic rules like wrong lane, jumping red light, etc.,
5. Carelessness on roads.
6. Driver falling asleep, fatigue or sick.
7. Mechanical defect of the vehicle.
8. Engineering/ Design fault of roads like road condition, sight distances, narrow roads, dangerous curves, etc.,
9. Improper street lighting.
10. Unfavourable weather conditions.



Activity 4

Prepare a report on a recently occurred road accident in your nearby locality, study the causes and give suggestion to prevent it.

6.9.2 Effects of Road Accidents

Road accidents can cause

1. Physical, financial and mental effects for everyone involved.
2. Drivers and passengers can suffer from minor cuts and bruises, broken limbs, back and spinal injuries, paralysis and even death.
3. Vehicles get damaged resulting in complete discarding.
4. Shattering of dreams from losing their loved one.



6.9.3 Prevention of Road Accidents

1. Never drink and drive.
2. Keep your eyes on the road.
3. Never use mobile phone while driving.
4. Follow speed limits.
5. Follow all the traffic rules and regulations.

6.10 Road Side Developments

Road side development deals with the development of aesthetic and other amenities of road and the abutting road or the right of way.



Road Accident Statistics in India

ROAD ACCIDENTS IN INDIA, 2016

17 deaths on India's roads every hour, Chennai and Delhi most dangerous

Official data show more people died on Indian roads in 2016 than in 2015; UP and Tamil Nadu accounted for the largest numbers of fatalities

BIG NUMBERS



FEWER ACCIDENTS, MORE DEATHS

| | 2015 | 2016 | % change |
|-----------|----------|----------|----------|
| Accidents | 5,01,423 | 4,80,652 | -4.1 |
| Killed | 1,46,133 | 1,50,785 | 3.2 |
| Injured | 5,00,279 | 4,94,624 | -1.1 |
| Severity* | 29.1 | 31.4 | 7.9 |

*Accident Severity is the number of persons killed per 100 accidents

HIGHWAYS NOT THE BIGGEST KILLERS

| Road type | Share of accidents | Share of accident deaths | Share of persons injured |
|-------------------|--------------------|--------------------------|--------------------------|
| National Highways | 29.6 | 34.5 | 29.6 |
| State Highways | 25.3 | 27.9 | 25.8 |
| Other roads | 45.1 | 37.6 | 44.6 |

All figures in per cent

SPEEDING BIGGEST PROBLEM, MOBILES AN ISSUE TOO

SPEEDING caused 68.5% of all road accidents and 61% of deaths
OVERTAKING caused 23% of all road accidents and 7.8% of deaths
INTAKE OF ALCOHOL/DRUGS caused 3.7% of all road accidents and 5.1% of deaths
TALKING OVER MOBILES caused 4,976 accidents, 2,138 deaths and 4,746 injuries

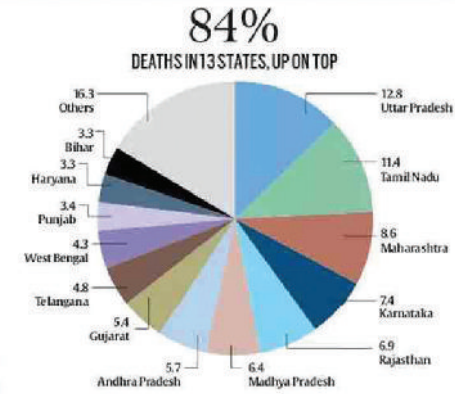

DELHI, CHENNAI ROADS MOST DANGEROUS

| | |
|--|-------|
| CHENNAI: LARGEST NUMBER OF ROAD ACCIDENTS, | 7,486 |
| DELHI: LARGEST NUMBER OF ROAD ACCIDENT DEATHS, | 1,591 |
| CHENNAI: LARGEST NUMBER OF INJURED PERSONS, | 7,349 |
| LUDHIANA: HIGHEST ACCIDENT SEVERITY, | 69.9 |

SPEEDBUMPS & POTHOLES KILLED 15 EVERY DAY

SPEEDBREAKERS CAUSED 9,583 road accidents and 3,396 people killed

POTHOLES LED TO 6,424 road accidents and 2,324 fatalities

NEWEST VEHICLES IN MOST ACCIDENTS

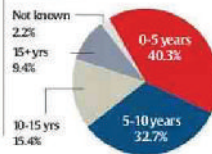

50 CITIES WITH MILLION-PLUS POPULATIONS ACCOUNTED FOR
 ■ 18.7% of all road accidents
 ■ 11.8% of all road accident fatalities
 ■ 16.7% of all persons injured in road accidents

CITIES WITH THE MOST DANGEROUS ROADS

| Cities | No. of accidents |
|-----------|------------------|
| Chennai | 7,486 |
| Delhi | 7,375 |
| Bengaluru | 5,323 |
| Indore | 5,143 |
| Kolkata | 4,104 |
| Mumbai | 3,379 |

Source: Road Accidents in India 2016, published by Transport Research Wing, Ministry of Road Transport & Highways, Government of India. Compiled on the basis of information collected from the police headquarters of various states and Union Territories and Million Plus Cities through specific designated nodal officers - DCP/ADCP, Crime-ALCP, Traffic; Director, State Crime Record Bureau - in the 17-item Asia Pacific Road Accident Data (APRAD) format.

6.10.1 Road Arboriculture

Road arboriculture or planting of trees on the road side is one of the important aspects in road side development.



(i) Purposes of Road Arboriculture

1. To provide aesthetically pleasing landscapes.
2. To provide shade to the road users.
3. To break the monotony of the driver.
4. To provide fruit bearing trees and timber.
5. To protect the soil from erosion
6. To purify the air.
7. To assist rainfall
8. To intercept the annoying sound waves and fumes from vehicles.
9. To act as a crash barrier for vehicles out of control.
10. To avoid head light glare during night driving.



**DO
YOU
KNOW?**

PIZHOU - The world's Longest Tree Avenue

Green space masterplan was done for the expansion of Pizhou City, China.

Pizhou's 47km long avenue of Dawn Redwood make it a world record. Dawn Redwood was discovered in China in 1944 and became the most famous 'fossil tree' of the last century.



(ii) Selection of Trees for Road Arboriculture

Trees are selected based on the following considerations

1. They should provide a large and dense crown.
2. They should be easy to establish, develop fast and be strong to resist heavy wind blows.
3. They should withstand lopping and pruning.
4. They should have long life.
5. They should yield atleast fruit or timber.
6. They should not be clumsy and should grow centrally.
7. They should provide shade always.
8. They should resist disease.



Activity 5

Collect pictures of various types of trees suitable for Road Arboriculture and prepare an album.

6.10.2 Highway Lighting

The highway lighting provides visual conditions for safe, quick and comfortable movement of road users. Highway lighting are provided at intersections, level crossings, bridge sites and at places where there is restriction to traffic movements.

(i) Lighting Layouts

Depending on the road category there are various arrangements for two way traffic roads, namely

- a. **Single sided lighting** – located on one side, if width of the road \leq mounting height. Luminance at the opposite remote end is lower than under the lamp.
- b. **Both side lighting - Staggered** – located on either side of the road in a staggered or zigzag fashion when width is 1 –1.5 times the mounting height. Here care is to be taken to avoid dark patches.
- c. **Both side lighting - Opposite** – located opposite to one another. When width is greater than 1.5 times the mounting height.
- d. **Span wire** – luminaires suspended along the axis of the road for narrow roads only. Suspended from cables strung between buildings.

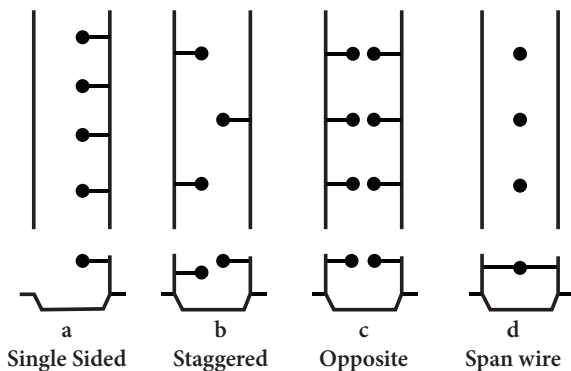

Lighting arrangement for 2 way Street

(ii) Design factors of Highway lighting

Following are the eight important factors to be considered in the design of highway lighting

1. Contrast
2. Glare
3. Lamps
4. Lateral placement of lighting poles
5. Lighting layouts
6. Luminaire distribution of light
7. Mounting height and overhang
8. Spacing of lighting units.

(iii) Benefits Of Highway Lighting

The various benefits of highway lighting are listed below

1. Reduces the risk of night time accidents.
2. Assist in the protection of property.
3. Making residents feel secure.
4. Illegal and anti-social activities on roads can be avoided.
5. Enhance the appearance of the area after dark.





MODEL QUESTIONS

Part – I

Choose the correct answer. (1 Mark)

- A conference of all the chief engineers of all the states and Provinces prepared the first 20-year road development plan and was popularly known as _____.
 - Jayakar Committee
 - Nagpur plan
 - Lord Dalhousie Committee
 - Public works Department
- Who formed the Public Works Department _____.
 - Lord Dalhousie
 - Sher Shah Suri
 - King Ashoka
 - Chandra Gupta Maurya
- _____ connect villages with one another and with nearby cities.
 - National highway
 - State highway
 - District roads
 - Village roads
- The structural foundation of the road is called _____.
 - Subgrade
 - Sub-base
 - Base course
 - Formation
- The road signs are classified into _____ categories.

| | |
|---------|----------|
| a. Two | b. Three |
| c. Four | d. Five |

- The slope of the line joining the crown and the edges of the road surface is called _____.
 - Gradient
 - Sight distance
 - Super Elevation
 - Camber



Part – II

Answer in one or two sentences. (3 Marks)

- Write short notes on Nagpur plan?
- List the uses of Camber.
- What is meant by sight distance?
- Define Soil Stabilization.
- List the tests conducted for aggregates.
- State the benefits of highway lighting.

Part – III

Answer briefly (5 Marks)

- Explain the history of road development in India.
- With neat sketch explain super elevation and list its advantages.
- List the merits and demerits of Cement Concrete road.
- Write briefly about Road Arboriculture

Part IV

Answer in detail (10 Marks)

- Explain the construction procedure for Earthen road with a neat sketch.
- Explain the construction procedure for Cement Concrete road with a neat sketch.
- Explain the causes, effects and prevention of road accidents.

1.(b), 2. (a), 3. (d), 4. (c), 5. (b), 6. (d)

Answers



HYDRAULICS

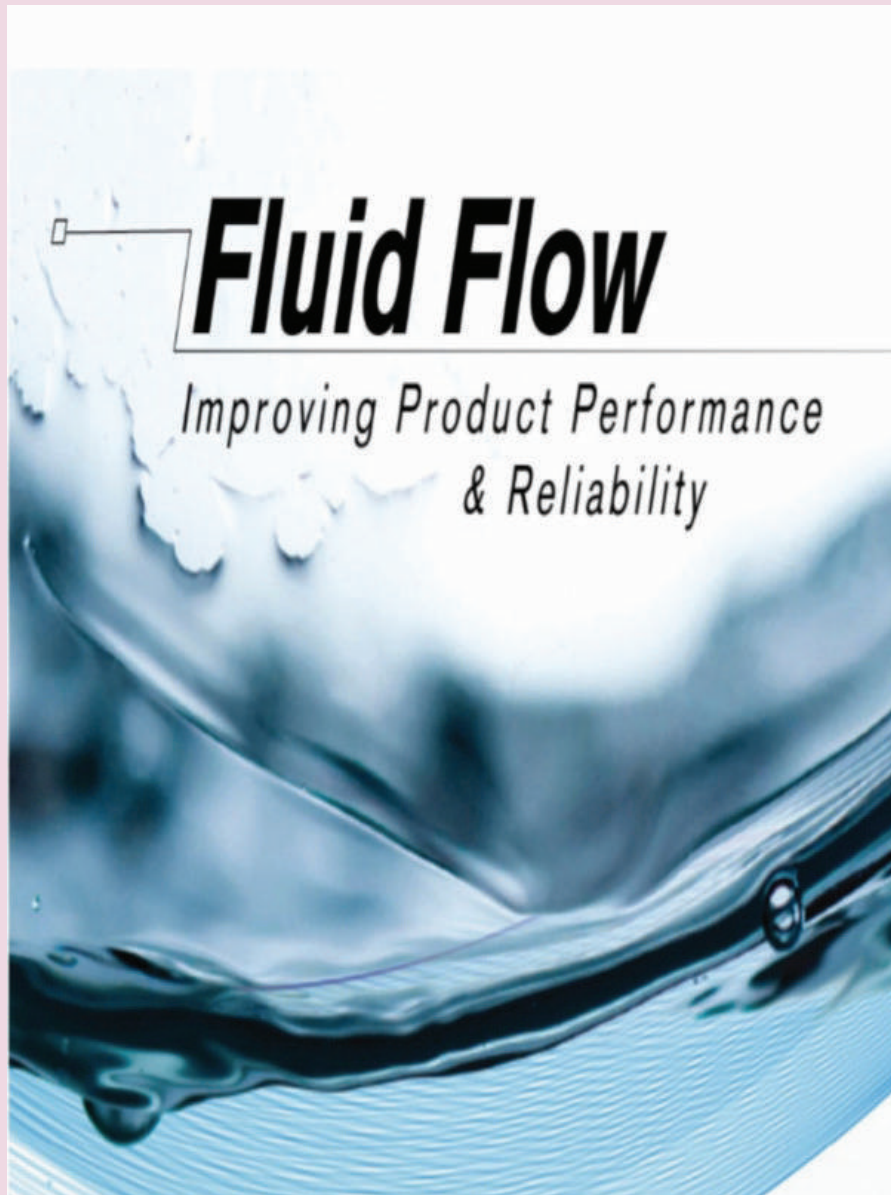

“ One small change can have an enormous impact. ”



Table of Contents

7.1 Introduction

- 7.1.1 Hydraulics - Definition
- 7.1.2 Fluids
- 7.1.3 Properties of fluids

7.2 Measurement of Pressure

- 7.2.1 Fluid Pressure
- 7.2.2 Pascal's Law
- 7.2.3 Intensity of Pressure
- 7.2.4 Pressure and Pressure head
- 7.2.5 Types of Pressure
- 7.2.6 Pressure measuring devices

7.3 Flow of fluids

- 7.3.1 Types of Flow
- 7.3.2 Energy possessed by a fluid body
- 7.3.3 Bernoulli's Theorem / Energy equation

7.4 Flow through Orifice and mouthpiece

- 7.4.1 Orifice - Definition
- 7.4.2 Types of Orifice
- 7.4.3 Jet of Water
- 7.4.4 Vena Contracta
- 7.4.5 Hydraulic Co-efficients for Small Orifice
- 7.4.6 Practical applications of Orifices

7.4.7 Mouthpiece - Definition

7.4.8 Types of Mouthpieces

7.5 Flow through pipes

- 7.5.1 Definition
- 7.5.2 Hydraulic gradient line
- 7.5.3 Total Energy line
- 7.5.4 Loss of head in pipes
- 7.5.5 Darcy's formula for loss of head in pipes in terms of velocity
- 7.5.6 Darcy's formula for loss of head in terms of discharge
- 7.5.7 Problems
- 7.5.8 Chezy's formula for velocity of flow in pipes
- 7.5.9 Chezy's formula for loss of head in terms of velocity

7.6 Pumps

- 7.6.1 Definition
- 7.6.2 Classification of pumps
- 7.6.3 Types of Reciprocating Pumps
- 7.6.4 Single acting Reciprocating pump
- 7.6.5 Double acting Reciprocating pump
- 7.6.6 Centrifugal pump
- 7.6.7 Priming of pump
- 7.6.8 Comparison between Centrifugal pump and Reciprocating pump

Learning Objectives

At the end of this lesson you shall be able to

- Understand fluids and its properties.
- List the types of pressure.
- Know the pressure measuring devices.
- Explain the different types of pipe flow.
- Understand Orifice, mouthpiece and its types.
- List the Classification of pumps.
- Explain the working of pumps

7.1 Introduction

7.1.1 Hydraulics – Definition

The branch of science, which deals with the properties and behavior of liquids is called 'Hydraulics'. It is otherwise called 'Hydromechanics'.

7.1.2 Fluids

Fluids are substances which are capable of flowing. They conform to the shape of the container. They change their shape even under the action of very small forces. They have some degree of compressibility and offer little resistance to change of form. They include liquids and gases.

7.1.3 Properties of Fluids

The following are the some of the properties of fluids.

1. Density
2. Specific weight
3. Specific gravity
4. Cohesion
5. Adhesion
6. Surface tension
7. Capillarity
8. Viscosity

1. Density

Density is defined as the mass per unit volume. It is also termed as mass density or specific mass. It is usually denoted by the Greek letter ρ (rho).

$$\text{Density} = \frac{\text{mass}}{\text{volume}} \quad \text{i.e., } \rho = \frac{m}{v}$$

Unit: kg/m^3

Density of pure water is 1000 kg/m^3 .

2. Specific weight

Specific weight is defined as the weight per unit volume. It is otherwise known as weight density. It is denoted by the Greek letter γ (gamma). Specific weight changes from place to place.

$$\text{Specific weight} = \frac{\text{Weight}}{\text{Volume}} \quad \text{i.e., } \gamma = \frac{W}{v}$$

Unit: N/m^3

Specific weight of pure water is 9.81 kN/m^3 .

3. Specific Gravity

Specific gravity is defined as the ratio of mass density of liquid to the

mass density of pure water at 4°C. It is also defined as the ratio of specific weight of liquid to the specific weight of pure water at 4°C. It is usually denoted by the symbol S . It has neither unit nor dimension. It is also called as relative density

Specific gravity/relative density

$$= \frac{\text{mass density of liquid}}{\text{mass density of pure water at } 4^{\circ}\text{C}}$$

$$S = \frac{\rho_l}{\rho_w}$$

Specific gravity/relative density

$$= \frac{\text{specific weight of liquid}}{\text{specific weight of pure water at } 4^{\circ}\text{C}}$$

$$S = \frac{\gamma_l}{\gamma_w}$$

4. Cohesion

Cohesion is the property of a liquid by which the molecules of the liquid are mutually attracted by each other. This property holds the molecules together.

Example: Mercury globules merge together and do not wet the surface of contact.

5. Adhesion

Adhesion is the property of a liquid by which the molecules of a liquid are attracted by the molecule of another kind of liquid or a solid. This property enables two different liquids adhere to each other or a liquid to adhere to solid body.

Example: Water drops adhere to the surface of contact rather than merging with each other.

6. Surface tension

Surface tension is a phenomenon in which the surface of a liquid, where the liquid is in contact with gas (such as air) acts like a thin elastic sheet. Surface tension is denoted by the Greek letter σ (sigma). It is expressed in Newton per metre i.e., N/m.

Examples:

- i. **Floating a needle:** A carefully placed small needle can be made to float on the surface of water even though it is several times denser than water.
- ii. **Walking on water:** Small insects such as the water strider can walk on water because their weight is not enough to penetrate the surface.

7. Capillarity

Capillarity is the rise or fall of a liquid in a capillary tube having small cross sectional



Father of Hydraulics

Joseph Bramah



| | |
|-----------|--|
| Born | 13 April 1748 Stainborough, Barnsley, Yorkshire, England |
| Died | 9 December 1814 (aged 66) Pimlico, London, England |
| Residence | London, England |
| Known for | Hydraulic press |

area like an opening in the porous materials. It occurs due to intermolecular forces between the liquid and surrounding solid surfaces. It is caused by the pressure of cohesion and adhesion, which works against gravity.

8. Viscosity

Viscosity is a physical property of fluids which shows resistance to flow. In a simple example, water has a low viscosity, as it is thin. Syrup and tar, on the other hand, have a high viscosity, as they are thick. It is denoted by the Greek letter μ (mu). It is expressed as Pa.s (Pascal second) i.e., N.s/m² or kg/ms.

7.2 Measurement of Pressure

7.2.1 Fluid pressure

Pressure is nothing but a force or weight. The fluid pressure at any point in a liquid is due to the weight of liquid standing above that point. Whenever a liquid (such as water, oil, etc) is in a vessel, it exerts force at all points on the side and bottom of the vessel. This fluid pressure is transmitted equally in all directions. It acts normal to the surface of contact.

7.2.2 Pascal's law

Pascal's law states that, "The pressure at any point in a static fluid (fluid at rest) acts equally in all directions".

Pressure at any point in vertical direction is only due to the weight of the liquid above that point. The liquid transmits pressure equally in all directions. Therefore, the pressure in vertical direction causes an equal horizontal pressure on the sides of the vessel.

7.2.3 Intensity of pressure

Intensity of pressure is the fluid thrust (push in a specified direction) per unit area.

It is also termed as unit pressure or simply pressure. It is denoted by the letter p . If P is the force acting on an area A . Then,

$$\text{Intensity of pressure, } p = \frac{P}{A}$$

It is expressed in N/m² or Pascal (Pa), kN/m² and N/mm²

7.2.4 Pressure and Pressure head

Pressure at a point in a liquid is represented by the equation $p = \gamma H$

Where, γ = specific weight

H = pressure head

The vertical height of a liquid producing a particular pressure is known as the pressure head.

7.2.5 Types of pressure

The pressure may be classified as

1. Static pressure
2. Atmospheric pressure
3. Gauge pressure
4. Absolute pressure

1. Static pressure

Static pressure is the pressure that a fluid exerts when it is not moving (at rest).

2. Atmospheric pressure

Atmospheric pressure is defined as the force per unit area exerted against a surface by the weight of the air above that surface.

3. Gauge pressure

Gauge pressure is the pressure relative to atmospheric pressure. Therefore, it is positive for pressures above atmospheric pressure and negative for pressures below it. The negative gauge pressure is also called vacuum pressure.

4. Absolute pressure

Absolute pressure is the pressure measured with absolute zero taken as a reference. Hence, a perfect vacuum called absolute zero is the datum. It is equal to gauge pressure plus atmospheric pressure.

7.2.6 Pressure measuring devices

The atmospheric pressure is measured by using a simple mercury barometer.

The fluid pressure can be measured by using the following devices.

1. Piezometer
2. Manometer
 - a. Simple U-tube manometer.
 - b. Differential manometer.
 - c. Inverted differential manometer.
 - d. Sensitive manometer or Micro manometer.
3. Mechanical Pressure Gauges
 - a. Bourdon's tube pressure gauge.
 - b. Diaphragm pressure gauge.
 - c. Dead weight pressure gauge.



Activity 1

Prepare an album of different types of pressure measuring devices.

7.3 Flow of Fluids

7.3.1 Types of flow

When a fluid flows in a pipe line, it meets with resistance at the contact surface. The flow has different patterns of motion. The pattern of flow depends upon the conditions of flow and the surface conditions. The flow may be steady or unsteady, laminar or turbulent and uniform or non-uniform.

1. Steady flow

A steady flow is the one in which the velocity of fluid flowing per second through any section is constant.

2. Unsteady flow

An unsteady flow is the one in which the velocity of fluid flowing per second through any section is not constant.

3. Laminar flow

In this flow, each particle of fluid moves strictly in a straight line as shown in fig. It is also called as stream-line flow. This is possible when,

- The fluid is highly viscous or thick.
- The size of the conduit is small.
- The velocity of fluid is very low.

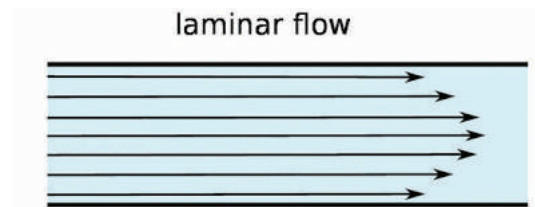

4. Turbulent flow

In this flow, the liquid particles do not have definite paths, but moves in a zig-zag way as shown in fig. Eddies or cross currents are created. Thus, the flow becomes very wavy along its path.

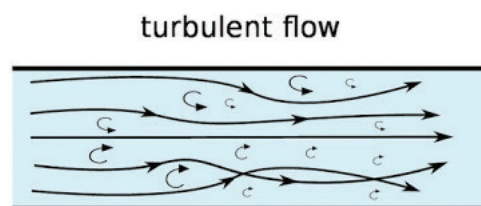

5. Uniform flow

In this flow, the magnitude and directions of velocities of fluid particles are same at all sections. Example: Constant discharge through a constant diameter pipe.

6. Non Uniform flow

In this flow, the magnitude and directions of velocities of fluid particles are not equal at all sections. Example: Constant discharge through a variable diameter pipe.

7.3.2 Energy possessed by a fluid body

Energy is the ability to do work. It is available in different forms. The energy possessed by a flowing fluid consists of energies due to position, pressure and velocity. They are classified as,

1. Potential energy or static energy or Datum energy.
2. Pressure energy.
3. Kinetic energy.

1. Potential energy

This is the energy possessed by a mass of fluid by virtue of its position in space.

2. Pressure energy

It is the energy possessed by a fluid particle by virtue of its existing pressure.

3. Kinetic energy

It is the energy possessed by a moving fluid particle by virtue of its motion or velocities.

4. Total energy

The total energy of a particle of a flowing fluid is the sum of its potential energy, pressure energy and kinetic energy.

7.3.3 Bernoulli's Theorem / Energy equation

Bernoulli's theorem states that "for a steadily flowing incompressible fluid, in which there is a continuous connection

between all the particles of the fluid, the total energy or total head of each particle is the same, provided there is no loss or gain of energy while the particle moves from one point to another".

Mathematically,

$$Z + \frac{v^2}{2g} + \frac{P}{\gamma} = \text{Constant}$$

Where,

Z = Potential energy or Datum head

$\frac{v^2}{2g}$ = Kinetic energy, (v = velocity of

flow, g = acceleration due to gravity)

$\frac{P}{\gamma}$ = Pressure energy, (P = Pressure, γ = unit weight of fluid)

7.4 Flow Through Orifice and Mouthpiece

7.4.1 Orifice – Definition

An opening provided in the side wall or base of a vessel, through which liquid is discharged, is called an Orifice. It is used to measure the discharge.

7.4.2 Types of Orifice

1. According to size
 - a. Small Orifice
 - b. Large Orifice
2. According to shape
 - a. Circular Orifice
 - b. Rectangular Orifice
 - c. Triangular Orifice

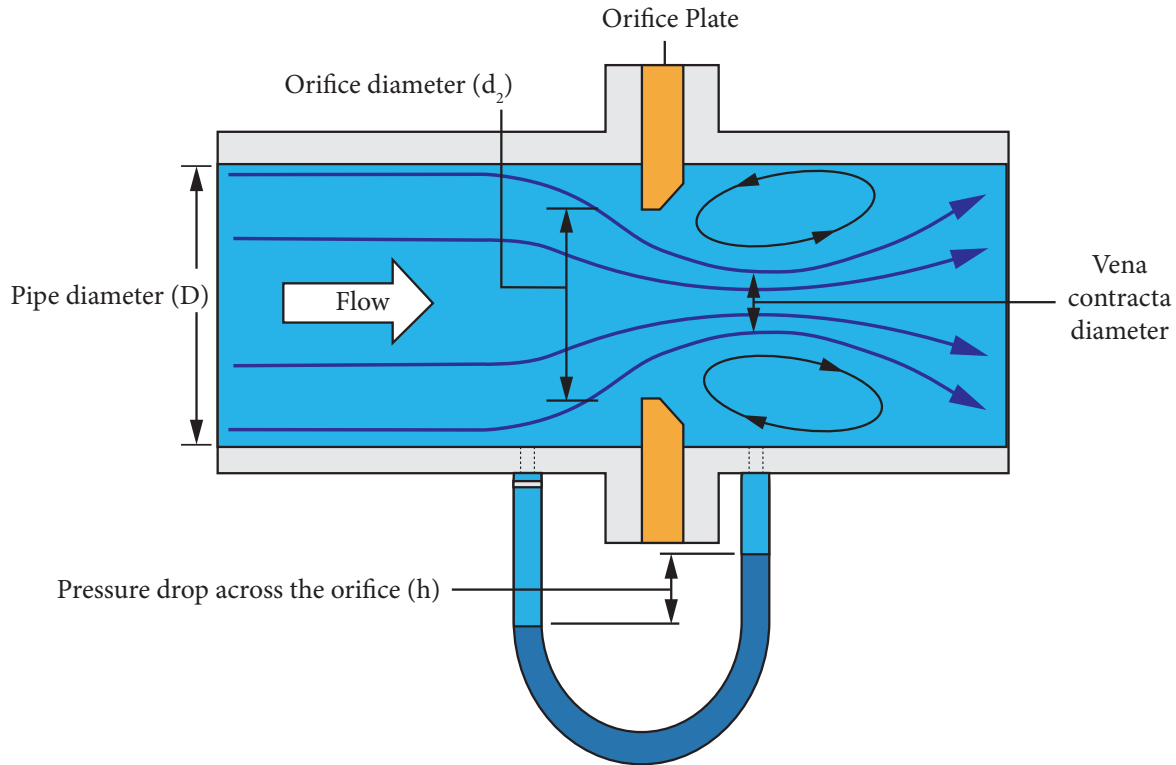

An Orifice plate with venacontracta

3. According to shape of the edge
 - a. Sharp-edged Orifice
 - b. Bell-Mouthed Orifice
4. According to nature of discharge
 - a. Fully submerged Orifice
 - b. Partially submerged Orifice

7.4.3 Jet of water

The continuous stream of water that comes out or flows out of an orifice / mouthpiece is known as jet of water.

7.4.4 Venacontracta

When a liquid flows out from a tank under pressure through an Orifice, the diameter of the jet of liquid will be equal to the diameter of the Orifice. But, the diameter of the jet and liquid contracts at a particular place away from the Orifice and then expands again.

The point at which the diameter of the jet contracts to the maximum is called 'Venacontracta'.

7.4.5 Hydraulic Coefficients for small Orifice

The following three coefficients are known as hydraulic coefficients or Orifice Coefficients.

1. Coefficient of contraction, C_C
2. Coefficient of velocity, C_V
3. Coefficient of discharge, C_d .

1. Coefficient of contraction

The ratio of the area of jet at vena contracta to the area of the Orifice is known as coefficient of contraction. It is denoted by C_C .

Coefficient of contraction, $C_c =$

$$\frac{\text{area of jet at venacontracta } (a_c)}{\text{area of Orifice } (a)}$$

i.e., $C_c = \frac{a_c}{a}$

2. Coefficient of velocity

The ratio of velocity of jet at vena contracta to the theoretical velocity is termed as coefficient of velocity. It is represented by C_v .

Coefficient of velocity, $C_v =$

$$\frac{\text{actual velocity of jet at venacontracta } (V_a)}{\text{theoretical velocity } (V_t)}$$

i.e., $C_v = \frac{V_a}{V_t}$

3. Coefficient of discharge

The ratio of actual discharge through the Orifice to the theoretical discharge is termed as coefficient of discharge. It is denoted by C_d .

Coefficient of discharge, $C_d =$

$$\frac{\text{actual discharge } (Q_a)}{\text{theoretical discharge } (Q_t)}$$

i.e., $C_d = \frac{Q_a}{Q_t}$

7.4.6 Practical applications of Orifice

1. Circular, square and rectangular sluices provided in irrigation tanks.
2. Vent ways of culverts.

3. The openings provided in swimming pools.
4. The openings of canal lock gates to fill up and empty.
5. The openings of balancing reservoirs and surge tanks.

7.4.7 Mouthpiece – Definition

A mouthpiece is a short length of pipe fitted to an Orifice either inwardly or outwardly. Generally, the length of the pipe varies from twice to thrice the diameter of Orifice. It is fitted to increase the discharge of the Orifice.

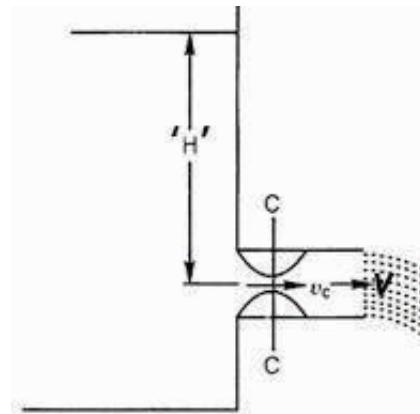

$V_c =$ Velocity at Venacontracta

$V =$ Velocity at Mouth piece



7.4.8 Types of mouthpieces

Mouthpieces are classified as below

1. According to location
 - a. Internal mouthpiece

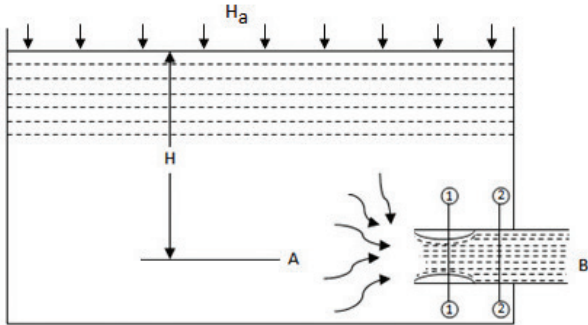

- b. External mouthpiece

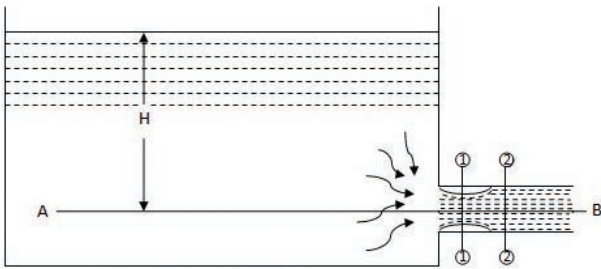

2. According to shape
 - a. Cylindrical mouthpiece
 - b. Convergent mouthpiece
 - c. Divergent mouthpiece
 - d. Convergent - divergent mouthpiece
3. According to nature of discharge
 - a. Running full
 - b. Running free

7.5 Flow Through Pipes

7.5.1 Definition

A pipe is a conduit, generally of circular cross section, used to carry liquid under pressure. When the pipe is running full, the flow is under pressure. This kind of flow is known as pipe flow. But, if the pipe is not running full, the flow is not under pressure. In such a case, the atmospheric pressure exist inside the pipe. This kind of flow is termed as channel flow.

7.5.2 Hydraulic gradient line

If pressure heads $\frac{P}{\gamma}$ of a flowing liquid in a pipe be plotted as vertical ordinates on the centerline of the pipe, then the line joining the tops of such ordinates is known as hydraulic gradient line (H.G.L).

7.5.3 Total energy line

If the sum of pressure heads and velocity heads $\left(\frac{P}{\gamma} + \frac{v^2}{2g}\right)$ of a liquid flowing in a pipe be plotted as vertical ordinates on the center line of the pipe, then the line

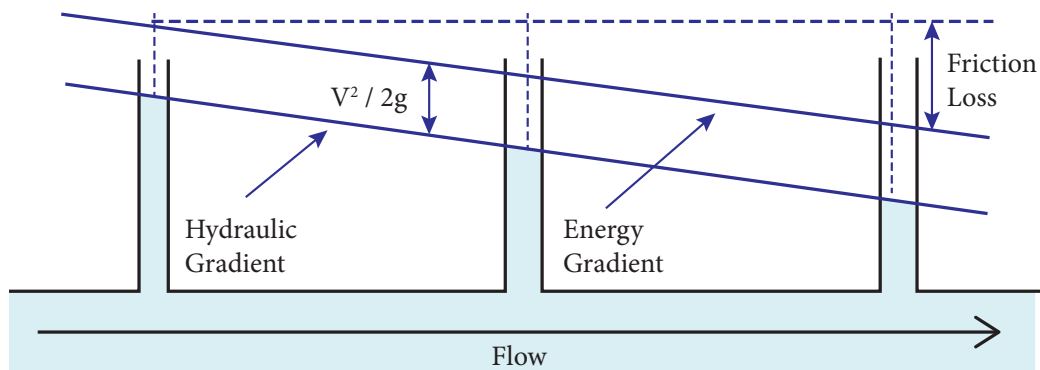

joining the tops of such ordinates is known as total energy line (T.E.L).

7.5.4 Loss of head in pipes

When a liquid flows under pressure in a pipe, there will be some losses. These losses are classified as below

1. Major or primary loss (frictional loss)
2. Minor or secondary loss (other losses)

Major loss is mainly due to viscosity, turbulence and roughness of pipe. This loss is called loss due to friction and is denoted by h_f . The losses due to other causes are called minor losses.

1. Major loss

When liquid is flowing in a pipe, it experiences some resistance to its motion due to friction offered by the inner surface of the pipe. This effect is to reduce

the velocity and ultimately the head of water. It has been experimentally found that more the roughness of the inside surface of the pipe, greater will be the resistance.

2. Minor losses

The following are the minor losses which occur in a pipe.

- a. Loss of head at inlet or entry of a pipe line.
- b. Loss of head due to pipe fittings.
- c. Loss of head due to change in direction.
- d. Loss of head due to sudden enlargement.
- e. Loss of head due to sudden contraction.
- f. Loss of head due to obstruction.
- g. Loss of head at exit of a pipe.

Minor Losses

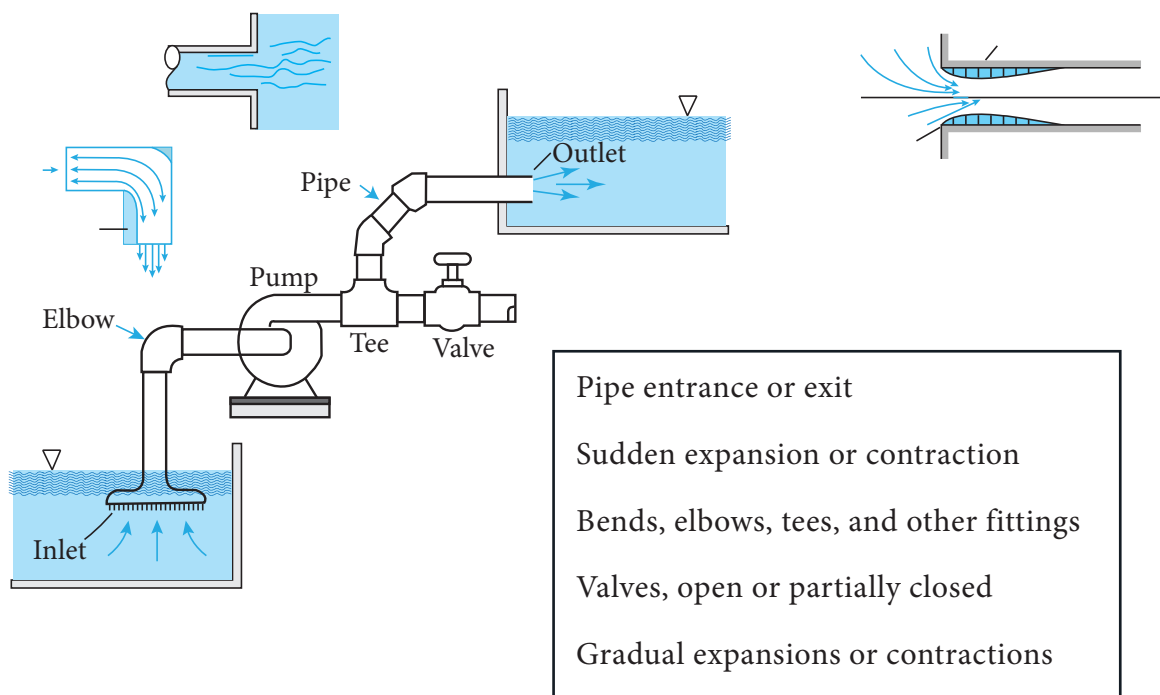

7.5.5 Darcy's formula for loss of head in pipes in terms of velocity

$$\text{Head loss due to friction (hf)} = \frac{flv^2}{2gd}$$

Where,

- f = coefficient of friction
- l = length of pipe
- v = velocity of water in the pipe
- g = acceleration due to gravity (9.81 m/s²)
- d = diameter of the pipe

7.5.6 Darcy's formula for loss of head in terms of discharge

$$\text{Head loss due to friction (hf)} = \frac{flQ^2}{12d^5}$$

Where,

- f = coefficient of friction
- l = length of pipe
- Q = discharge of water from the pipe
- d = diameter of the pipe

7.5.7 Problems

Example – 1

Water flows through a pipe of 100 mm diameter and 120 m long with a velocity of 3 m/sec. Find the loss of head due to friction by using Darcy's formula. Take the friction factor as 0.002.

Given data:

- Diameter of pipe (d) = 100 mm = 0.10 m
- Length of pipe (l) = 120 m
- Velocity of flow (v) = 3 m/sec

Friction factor (f) = 0.002

To find out:

Loss of head due to friction (h_f)

Solution:

Loss of head due to friction

$$\begin{aligned} (h_f) &= \frac{flv^2}{2gd} \\ &= \frac{0.002 \times 120 \times 3^2}{2 \times 9.81 \times 0.10} = 1.10 \text{ m} \end{aligned}$$

Result:

Loss of head, $h_f = 1.10$ m

Example – 2

A pipe line, 300 mm diameter and 400 m long connects two reservoirs. The discharge through the pipe is 191 lps. Taking the friction factor as 0.002, determine the loss of head due to friction.

Given data:

- Diameter of the pipe (d) = 300 mm = 0.30 m
- Length of the pipe (l) = 400 m
- Discharge of water (Q) = 191 lps = 0.191 m³/sec
- Friction factor (f) = 0.002

To determine:

Loss of head due to friction, h_f

Solution:

Loss of head due to friction

$$\begin{aligned} (h_f) &= \frac{flQ^2}{12d^5} \\ &= \frac{0.002 \times 400 \times 0.191^2}{12 \times 0.30^5} \\ &= 1.00 \text{ m} \end{aligned}$$

Result:

Loss of head, $h_f = 1.00$ m.

Example – 3

The difference in head between two ends of a pipeline, 400 m long and 200 mm diameter is 2 m. Find out the discharge through the pipe by taking friction factor as 0.003. Neglect minor losses.

Given data:

| | |
|-------------------------|----------|
| Length of pipe (l) | = 400 m |
| Diameter of pipe (d) | = 200 mm |
| | = 0.20 m |
| Difference in head (hf) | = 2 m |
| Friction factor (f) | = 0.003 |

To find out:

Discharge through the pipe, Q

Solution:

Loss of head due to friction,

$$h_f = \frac{fQ^2}{12d^5}$$

$$\text{i.e., } 2 = \frac{0.003 \times 400 \times Q^2}{12 \times (0.20)^5}$$

$$2 \times 12 \times (0.20)^5 = 0.003 \times 400 \times Q^2$$

$$\therefore Q^2 = \frac{2 \times 12 \times (0.20)^5}{0.003 \times 400} = 0.0064$$

$$Q = \sqrt{0.0064} = 0.08 \text{ m}^3/\text{sec}$$

Result:

Discharge through the pipe

$$(Q) = 0.08 \text{ m}^3/\text{sec}$$

7.5.8 Chezy's formula for velocity of flow in pipes

$$\text{Velocity, } v = c\sqrt{mi}$$

Where,

v = velocity of flow

c = chezy's constant

m = Hydraulic mean depth

i = Hydraulic gradient

Hydraulic mean depth

$$(m) = \frac{\text{Area of pipe (A)}}{\text{wetted perimeter (p)}}$$

Wetted perimeter of pipe (p) = πd

$$\text{Area of pipe (A)} = \frac{\pi d^2}{4}$$

$$\therefore m = \frac{A}{p} = \frac{\left(\frac{\pi d^2}{4}\right)}{\pi d} = \frac{d}{4}$$

Hydraulic mean depth, $m = \frac{d}{4}$

Hydraulic gradient, $i = \frac{h_f}{l}$

7.5.9 Chery's formula for loss of head in terms of velocity

We know, Velocity, 'v' = $c\sqrt{mi}$

$$v = c\sqrt{m \times \frac{h_f}{l}} \quad \left(i = \frac{h_f}{l}\right)$$

Squaring on both sides,

$$v^2 = c^2 \times m \times \frac{h_f}{l}$$

$$v^2 \times l = c^2 \times m \times h_f$$

$$\therefore h_f = \frac{v^2 l}{c^2 m}$$

Loss of head due to friction, $h_f = \frac{v^2 l}{c^2 m}$

Example – 4

A 300 mm diameter and 600 m long pipe connects two reservoirs. The difference in water levels between the reservoirs is 3 m. Determine the velocity of flow in the pipe. Take Chezy's constant as 60.

Given data:

| | |
|-------------------------------------|----------|
| Diameter of pipe (d) | = 300 mm |
| | = 0.30 m |
| Length of pipe (l) | = 600 m |
| Difference in water level (h_f) | = 3 m |
| Chezy's constant (c) | = 60 |

To determine:

Velocity of flow in the pipe (v)

Solution:

$$\text{Velocity of flow, } v = c\sqrt{mi}$$

Hydraulic mean depth,

$$m = \frac{d}{4} = \frac{0.30}{4} = 0.075 \text{ m}$$

Hydraulic gradient,

$$i = \frac{h_f}{l} = \frac{3}{600} = 0.005$$

$$\therefore \text{Velocity, } v = c\sqrt{mi}$$

$$= 60 \times \sqrt{0.075 \times 0.005} = 1.162 \text{ m/s}$$

Result:

$$\text{Velocity of flow, } v = 1.162 \text{ m/s}$$

Example – 5

Water flows through a pipe, 50 mm diameter and 20 m long with a velocity of 3 m/sec. Find out the loss of head due to friction. Take Chezy's constant as 60.

Given data:

| | |
|----------------------|------------------|
| Diameter of pipe (d) | = 50 mm = 0.05 m |
| Length of pipe (l) | = 20 m |
| Velocity of flow (v) | = 3 m/s |
| Chezy's constant (c) | = 60 |

To find out:

Loss of head due to friction, h_f

Solution:

We know, Chezy's formula for loss of

head in terms of velocity $h_f = \frac{v^2 l}{c^2 m}$

$$\text{Hydraulic mean depth, } m = \frac{d}{4} = \frac{0.05}{4} = 0.0125 \text{ m}$$

Head loss due to friction,

$$h_f = \frac{v^2 l}{c^2 m} = \frac{3^2 \times 20}{60^2 \times 0.0125} = 4 \text{ m}$$

Result:

Loss of head due to friction, $h_f = 4 \text{ m}$.

7.6 Pumps

7.6.1 Definition

A pump is a device that moves fluids (liquids or gases) or sometimes slurries by mechanical action. There are two basic classification of pumps. They are,

- Positive displacement pumps
- Rotodynamic pumps

7.6.2 Classification of Pumps

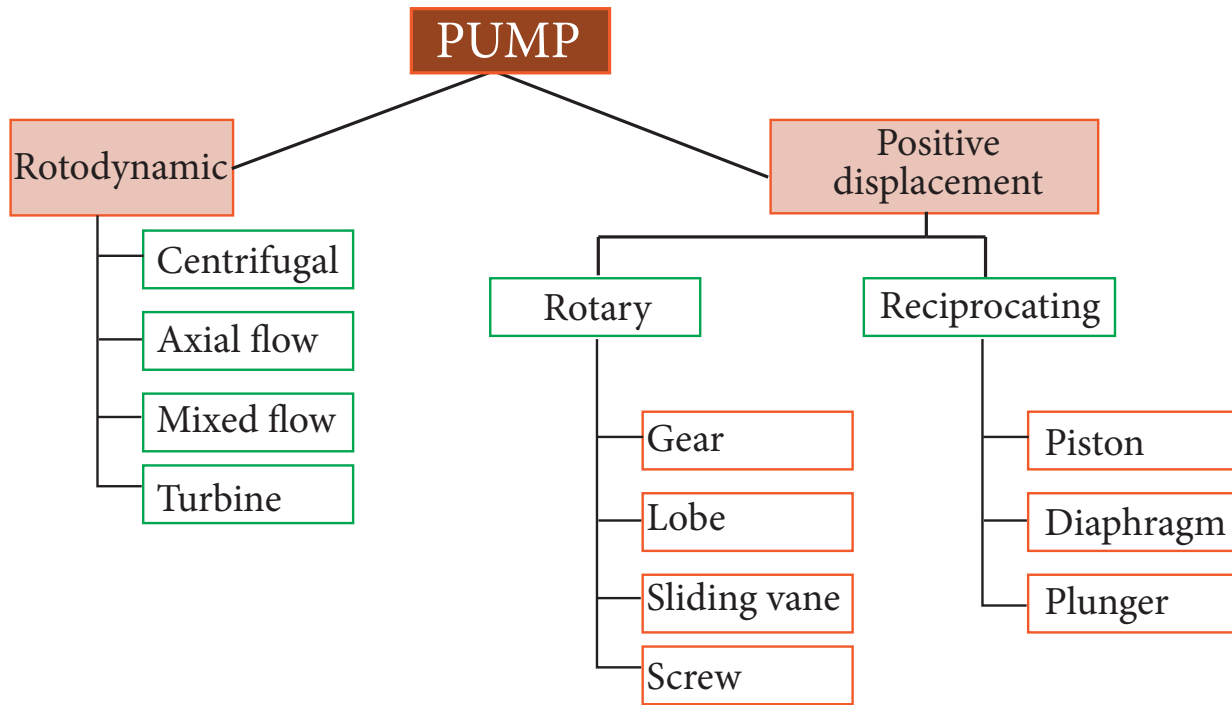

7.6.3 Types of Reciprocating pumps

The following are commonly known types of reciprocating pumps.

- **Single acting reciprocating pump:**
This has one suction valve and one delivery valve.
- **Double acting reciprocating pump:**
Unlike single acting pump, here there are two suction and delivery valves.

7.6.4 Single acting Reciprocating pump

Structure: A piston or a plunger moves to and fro in a stationary cylinder, alternatively drawing in and pushing out liquid through valves. The suction and delivery pipes are connected to cylinder where suction valve and delivery valve are connected respectively. Piston rod and

connecting rod are connected to crank. This revolving crank moves the piston forward and backward in the cylinder. The length of travel of the piston is known as the stroke, which should be equal to the diameter of the crank wheel.

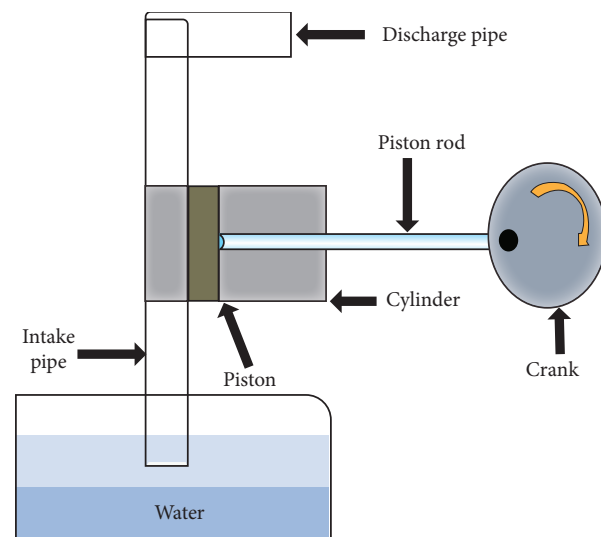

Working

Action 1: The piston is pulled back. This action increases the volume of the cavity (cylinder). As the cavity volume expands, fluid is drawn in through the inlet to fill the expanded cavity (Suction stroke).

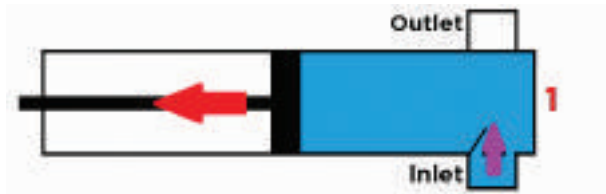

Action 2: The piston has reached its maximum displacement. Since it is not moving into or out of the cavity, fluid is not following through the inlet or the outlet.

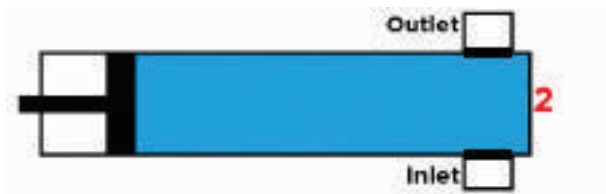

Action 3: The piston is then pushed back into the cavity. During this process, the piston applies enough pressure in the outlet of the pump. This pressure pushes the fluid from inside the cavity through outlet of the pump. (Delivery stroke)

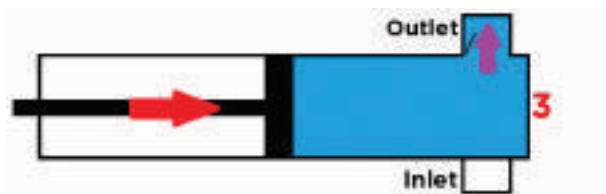

Action 4: The piston reaches its maximum extension into the cavity. Here the volume of the cavity is at a minimum and fluid is not flowing through the inlet or the outlet. The next action repeats the process starting again with action 1.

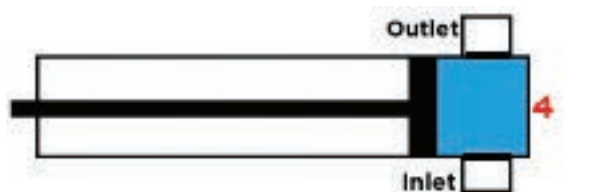

7.6.5 Double acting reciprocating pump

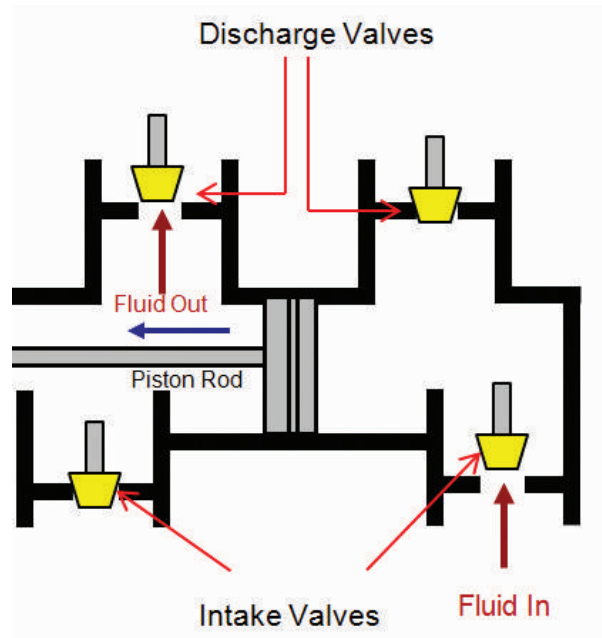

Working

It is similar to single acting reciprocating pump. It has two suction and two delivery pipes and valves on either side of the piston connected to the cylinder

When piston moves, water is collected on one side and discharged on other side, so the water is discharged continuously.

There are two suction strokes and delivery strokes during each revolution of the crank. Thus, water is supplied uniformly in the delivery pipe and the quantity of discharge is double that of single acting reciprocating pump.

7.6.6 Centrifugal Pump

A hydraulic machine which converts the mechanical energy into the pressure energy by means of centrifugal force, used to pump a fluid is called centrifugal pump.

The following are the main parts of centrifugal pump.

- Impeller
- Casing
- Suction pipe with foot valve
- Strainer
- Delivery pipe
- Prime mover

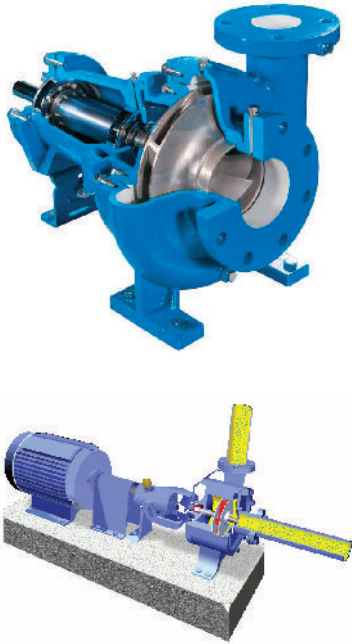

Impeller

It is the rotating part of the pump. The impeller is mounted on a shaft and is connected with an electric motor. It is rotated by the motor and consists of series of backward curved blades.



Casing

It is an air tight passage which surrounds the impeller. The design of the casing is done in such a way that it is capable of converting the kinetic energy of the water discharging from the outlet

of the impeller into pressure energy before it leaves the casing and enters into the delivery pipe.



History of Centrifugal pumps

- The inventor not be named with assurance.
- In the 17th century, Jordan an Italian had made some drawing of a centrifugal pump.
- In the early 18 century, French physicist Papin built a centrifugal pump of primitive design.
- In 1732 Demour pumps was put on service in France.
- In 1818 Andrews (USA) built a single stage centrifugal pump.
- Then many developments came in the industry.



Suction Pipe with Foot Valve

A pipe whose one end is connected with the inlet of the pump and the other end is dipped into the sump of water is called suction pipe.

The suction pipe consists of a foot valve and strainer at its lower end. The foot valve is a one way valve (Non-return

valve / NRV) that opens only in the upward direction.

Strainer

The strainer is used to filter the unwanted particle present in the water to prevent the centrifugal pump from blockage.

Delivery Pipe

It is a pipe whose one end is connected to the outlet of the pump and other end goes up to the required height where water is to be delivered.

Prime mover

It is an electric motor or oil engine to drive the pump.

Working

As the electric motor starts rotating, it also rotates the impeller. The rotation of the impeller creates suction at the suction pipe. Due to suction created, the water from the sump starts coming to the casing through the eye of the impeller.

From the eye of the impeller, due to the centrifugal force acting on the water, the water starts moving towards the outer of casing.

Because of the impeller rotating at high velocity, it also rotates the water

around it in the casing. As the area of the casing increases gradually in the direction of rotation, the velocity of the water decreases and the pressure increases at the outlet of the pump. Here the pressure is maximum.

Now from the outlet of the pump, the water goes to its desired location through the delivery pipe.

Uses

The centrifugal pump is used to raise the liquid from lower level to higher level. They are mostly used at home for filling overhead water tanks, in industries, for irrigation, etc.

7.6.7 Priming of pump

It is the process in which the suction pipe, casing and delivery pipe upto the delivery valve is filled completely with liquid to be raised from outside source before starting the motor. Priming is done to remove the air from the pump.

If air is not removed from the pump a small negative pressure created at the suction pipe doesnot allow to suck the water. So it is advised to fill the pump with water before starting it.

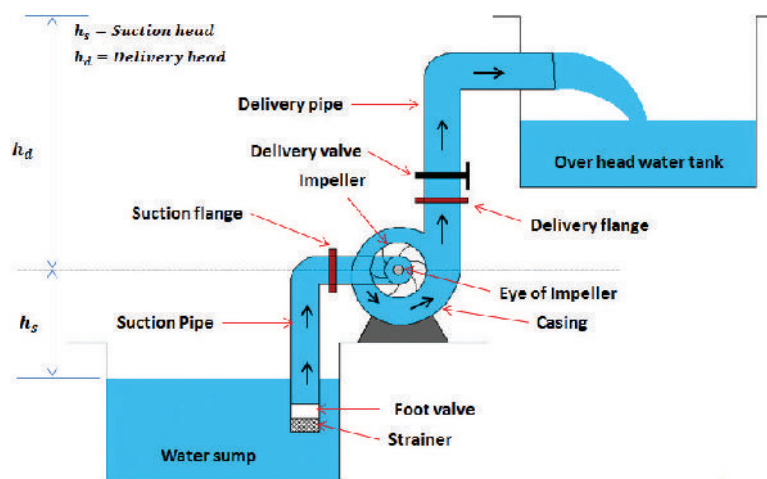

Centrifugal Pump



Activity 2

Collect the pictures of different types of pumps and prepare an album.

7.6.8 Comparison between Centrifugal Pump and Reciprocating Pump

| Centrifugal pumps | Reciprocating Pumps |
|---|---|
| 1. The discharge is continuous and smooth | 1. The discharge is fluctuating and pulsating |
| 2. It can handle large quantity of liquid | 2. Handles small quantity of liquid |
| 3. It is used for large discharge through small heads | 3. It is meant for small discharge at high heads |
| 4. Cost of centrifugal pump is less as compared to reciprocating pump | 4. Cost of reciprocating pump is approximately four times the centrifugal pump. |
| 5. Runs at high speed | 5. Runs at low speed |
| 6. Efficiency is high | 6. Efficiency is low |
| 7. Needs smaller area and cost of installation is less | 7. Needs large area and installation cost is high |
| 8. Low maintenance cost | 8. High maintenance cost |
| 9. It can also be used for lifting highly viscous liquids | 9. Used only for lifting pure water or less viscous liquids |



MODEL QUESTIONS



Part – I

Choose the Correct answer (1 Mark)

- Density of pure water is _____.
a. 2000 kg/m³ b. 1000 kg/m³
c. 1500 kg/m³ d. 2500 kg/m³
- The unit for surface tension is _____.
a. N/mm b. N/mm²
c. N/m d. N/cm
- The pressure happens when a fluid is at rest is _____.
a. Static Pressure
b. Gauge Pressure
c. Absolute Pressure
d. Vacuum Pressure
- In steady flow, the quantity of flowing liquid is _____.
a. Non Constant b. unsteady
c. constant d. varying
- An Orifice is used to measure the _____ of liquid.
a. Velocity b. Head loss
c. Pressure d. Discharge
- Head loss due to friction in a pipe is denoted by _____.
a. h_f b. f_h
c. Q d. v

Part – II

Answer in one or two sentences (3 Marks)

- List any four properties of fluids.
- Write short note on Density.
- Define Pascal's Law?
- List the types of Pressure.
- List out the types of liquid flow.

- Define – Orifice.
- Write the types of mouthpieces according to its shape.
- Write the Darcy's formula to find out loss of head.
- What do you mean by pump?

Part – III

Answer in brief (5 Marks)

- Write briefly about
(a) Fluid pressure.
(b) Intensity of pressure.
- State the Bernoulli's Theorem or Energy equation.
- Write briefly about Vena contracts with simple sketch.
- Write briefly about Hydraulic gradient line with sketch.

Part – IV

Answer in detail (10 Marks)

- Water flows through a pipe of 250 mm diameter and 200 m long with a velocity of flow 2.75 m/s. Find the loss of head due to friction. Take friction factor (f) as 0.003
- Determine the loss of head in a pipe line 200 mm diameter and 450 m long. The discharge of water through the pipe is 0.255 m³/s. Take the value of friction factor as 0.002.
- Water flows through a pipe line 150 mm diameter and 400 m long. The velocity of flow of water in the pipe is 2.5 m/s. Find out the loss of head in the pipe by taking Chezy's constant as 40.

1. (b) 2. (c) 3. (a) 4. (c) 5. (d) 6. (a)

Answers



DISASTER MANAGEMENT



“ Preparedness is the only way we can combat a natural disaster. ”

John Quinlan



Table of Contents

8.1 Introduction

8.2 Types of Disaster

8.2.1 Natural Disaster

8.2.2 Man – made Disaster.

8.3 Earthquake

8.3.1 Causes of Earthquake

8.3.2 Effects of Earthquake

8.3.3 Precaution to be taken

8.4 Cyclone

8.4.1 Causes of Cyclone

8.4.2 Effects of cyclone

8.4.3 Precaution to be taken

8.5 Floods

8.5.1 Causes of flood

8.5.2 Effects of flood

8.5.3 Precaution to be taken

8.6 Oil Spills

8.6.1 Causes of Oil Spills

8.6.2 Effects of Oil Spills

8.6.3 Precautions to be taken

8.7 Human Stampede

8.7.1 Causes of Human Stampede

8.7.2 Effects of Human Stampede

8.7.3 Precautions to be taken

8.8 Nuclear Disaster

8.8.1 Causes of Nuclear Disaster

8.8.2 Effects of Nuclear Disaster

8.8.3 Precautions to be taken

Learning Objectives

At the end of this lesson you shall be able to

- Explain disaster and its types.
- Explain the causes, effects and precautions to be taken on various disasters.

8.1 Introduction

Disaster is a sudden extreme, calamitous event bringing great damage, loss to life and property. The damage caused by disasters is immeasurable and varies with the geographical location, climate and type of the earth surface. This influences the mental, socio-economic, political and cultural state of the affected area. Generally disaster has the following effects in the concerned areas,

- It completely disrupts the normal day to day life

- It negatively influences the emergency systems
- Normal needs and processes like food, shelter, health, etc., are affected and deteriorate depending on the intensity and severity of the disaster.

8.2 Types of disaster

Generally, disasters are of two types –

- Natural disaster
- Man-made disaster

8.2.1 Natural Disaster

A Natural Disaster is a major adverse event that is caused by the natural forces of the earth where great damage and some times loss of life occurs.

The following are the examples of natural disaster.

- Cyclone
- Earthquake
- Flood
- Tsunami
- Landslide
- Volcanic eruption

Among these cyclone, earthquake and flood are frequently happening disasters in India.

8.2.2 Man-Made Disaster

The developmental activities of the human being through improper intervention with nature have also increased the degree of occurrence of natural disasters in many folds. This mainly involves situations in which civilian populations suffer casualties, losses of property, basic services and means of livelihood as a result of war, civil strife or other conflicts.

The following few types of disasters are explained in detail in this chapter:

8.3 Earthquake

An earthquake is a trembling or shaking movement of the earth's surface, resulting from plate movements along a fault-plane or as a result of volcanic activity.

The location at which the seismic waves started propagating from the deep subsurface is known as Focus. The spot on the earth surface just above the Focus

is known as Epicentre. Earthquakes can strike suddenly, violently and without warning at any time of the day or night.

Earthquake magnitude is a measure of the "size" or amplitude, of the seismic waves generated by an earthquake source and recorded by seismographs. Richter scale is commonly used today to measure the magnitude of earthquake.

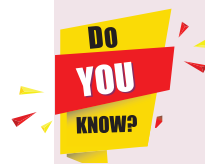

In 2001 Gujarat earthquake also known as the Bhuj earthquake is one of the vulnerable earthquake occurred in India. It occurred on 26th January India's 52nd Republic Day at 8.46 AM IST and lasted for over two minutes at a magnitude of 7.7 Richter. The epicentre was about 9 km south – west of the village of Chobari in Bhachau taluk of Kutch district.



8.3.1 Causes of Earth quake

- Seismic Waves
- Compression in the earth's crust
- Groundwater extraction
- Geothermal drilling
- Tectonic movements of the earth
- Volcanic eruptions

- Disturbance on the earth's surface
- Powerful bomb blast

8.3.2 Effects of Earth quake

- Ground shaking
- Differential ground settlement
- Soil liquefaction
- Immediate landslides, avalanches, etc.
- Permanent ground displacement along faults
- Floods from tidal waves, sea surges and Tsunami
- Dam failures
- Pollution from damage industrial plants
- Delayed landslides

8.3.3 Precautions to be taken

- Educate yourself and family members.
- Minimize your movements to a few steps that reach a nearby safe place.
- Stay indoors until the shaking has stopped and you are sure exiting is safe.
- DROP to the ground; take COVER by getting under a sturdy table or any other of furniture; and HOLD ON until the shaking stops.

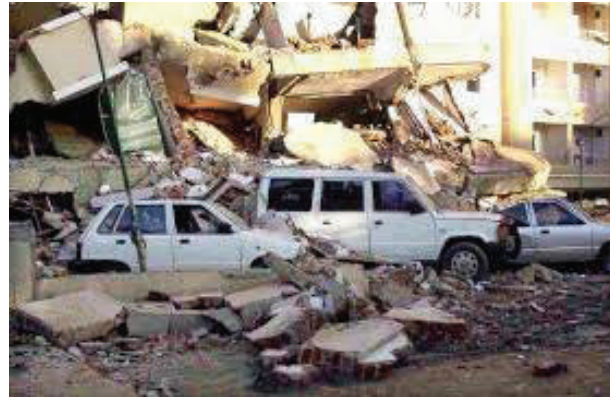

- If you are outside, move away from buildings, trees, streetlights, and utility wires.

8.4 Cyclone

Cyclone is one among the major climatic disaster caused due to the low pressure development over the Ocean surface naturally.

It is a derivative of the Greek word “Cyclos” that means ‘coils of a snake’.

8.4.1 Causes of Cyclone

The low pressure is formed over the ocean surface due to warming up of ocean water. Subsequently hot moisture air formed near will start moving up due to its light density. As a result, low pressure surface is formed in that surface area. In order to equalize the pressure, little high dense air from the surrounding will move towards the low pressure area. Again they get warmed up and raises above. During their raise, the hot moisture air gets cooled and condensed to form cloud. Then at certain heights it moves laterally either anti-clockwise or clockwise direction because of the Coriolis effect (Earth's self-rotation). This movement forms an eye at the center. Whenever it gains a rapid circulation, it is known as Cyclone.

8.4.2 Effects of Cyclone

The main effects of cyclones includes

- Heavy rain
- Strong wind
- Large storm surges near land fall
- Tornadoes

8.4.3 Precautions to be taken

Before cyclone:

- Check the house, secure loose tiles and carry out repairs of doors and windows.
- Remove dead branches or dying trees close to the house, anchor removable objects which can fly in strong winds.
- Keep some wooden boards ready so that glass windows can be boarded if needed.
- Keep candles, hurricane lantern filled with kerosene, battery operated torches with enough dry cells.



World's biggest Tsunami

The largest recorded Tsunami with a wave height of 1720 feet in Lituya Bay, Alaska on the night of 9th July, 1958. In India, the biggest Tsunami occurred on 26th Dec 2004.



After cyclone :

- Don't go outside until officially advised it is safe.
- Check for gas leaks.
- Listen to the local radio for official warning and advice.
- If you have to evacuate, or if did so, do not return until advised.
- Beware of damaged power lines, bridges, buildings and trees.
- Don't enter into flood waters.

8.5 Floods

The natural rainstorm, heavy rain and cyclonic cloud burst brings huge quantum of surface water as flood and destroys the low-lying area by washing out all the resources and properties all along its flow path and by inundation.

Different types of floods classified based on the type of occurrence are:

- Flashflood
- dam failure flood
- overland flood
- coastal zone flood
- cloud burst flood
- snow melt flood
- seasonal flood.





8.5.1 Causes of Flood

Following are some of the most common causes of flood.

- Heavy rains
- Overflow rivers
- Broken dams
- Storm surges and Tsunami
- Melting snow and ice

8.5.2 Effects of Flood

- Economic loss to farmers as agricultural lands, crops being submerged in water.



Malpa Landslide

The Malpa Landslide was one of the worst landslide in India. On 18th Aug 1998 at 3.00AM. the massive landslide wiped away the entire village of Malpa Landslide in the Pithoragarh District of Uttarakhand.



- They wreck houses, particularly kuccha houses in villages.
- They causes disruption of all types of transport and communication.
- There is a shortage of drinking water.
- They harm human, animal and plant life.
- They cause a rise in epidemics because of water logging (like Malaria, Diarrhoea, etc.)

8.5.3 Precaution to be taken

During flood

- Seek higher ground.
- Be aware of flash flood areas such as canals, streams, drainage channels.
- Be ready to evacuate.
- Don't touch electrical equipment if wet.
- If you must leave your home, do not walk through moving water.
- Do not drive over a flooded road.

After flood

- Stay away from flood water.
- Do not attempt to swim, walk or drive through the area.
- Be aware of areas where water has reduced. Road ways may have weakened and could collapse.
- Avoid downed power lines and muddy waters where power lines may have fallen.
- Do not drink tap water until advised by the health unit.
- Flood contaminated rooms have to be thoroughly cleaned and disinfected.
- Floor drains and sumps have to be cleaned and disinfected.



Activity 1

Collect the details and images of recent Cyclones and prepare an album.

8.6 Oil Spills

Oil spill is an accidental or intentional release of liquid petroleum hydrocarbon into the ocean or coastal waters mainly due to human activity.



8.6.2 Effects of Oil Spill:

- Oil spills can have terrible consequences for society (economically, environmentally and socially).
 - Affects entire marine life.
 - Blocks entrance of oxygen into water.

8.6.1 Causes of Oil Spills

- Sinking or leakage of oil carrying vessels or oil pipelines.
- Illegal dumping by industries.
- Countries at war.
- Terrorist activity.
- Due to Natural disasters.

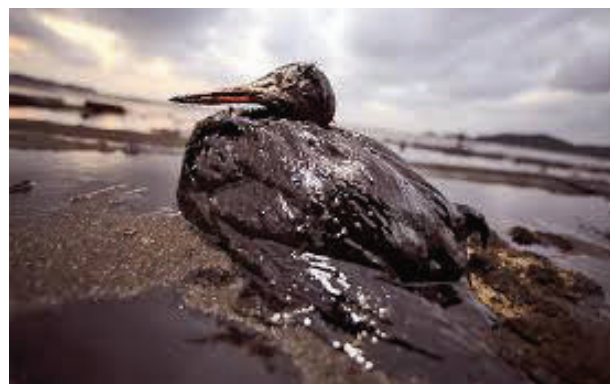



- Affects the food bed when oil reaches sea bed.
- Natural recovery process may require more than 10 years.

8.6.3 Precautions to be taken

- Build double hull.
- Installing Blowout preventers.
- Better training of ship and oil rig personnel.
- Prediction of weather and ocean conditions.



8.7 Human Stampede:

A stampede is an act of mass impulse among herd animals or a crowd of people in which the herd or crowd collectively begins running with no clear direction or purpose often in an attempt to escape a perceived threat.

8.7.1 Causes of Human Stampede

- **Force** of the crowd or crowd pressure.
- **Information** upon which the crowd acts or reacts.
- **Space** involved in the crowd incident, and standing area, physical facilities like stairs, corridors, escalators.
- **Time** or duration of incident.



8.7.2 Effects of Human Stampede

- Loss of life.
- Damage to public property.
- Tangible costs (repair costs, medical costs, etc.)
- Intangible costs (pain, sufferings, etc.)
- Hospitalization.
- Handicap.

8.7.3 Precautions to be taken

- Study the event and its location thoroughly.



- Do not take kids or the elderly in any such area or event.
- Keep minimum things to carry with you.
- Do not panic.

8.8 Nuclear Disaster

According to International Atomic Energy Agency, a nuclear and radiation accident is defined as “an event that has led to significant consequences to people, the environment or the facility”.

- Nuclear weapons are more destructive and harmful to the society than any other weapon.



8.8.1 Causes Nuclear Disaster

- The main causes is due to meltdowns that occur in a reactor.



Meltdown



8.8.2 Effects of Nuclear Disaster

- Emitting radiations, can be caused health disorders.
- Disease like Thyroid cancer, mental illness, rise in abortion and various physical disability occurs.
- Fatality rate is more.
- Adverse effects on vegetation, animals, aquatic life and human beings.
- Has both **immediate** effects (Significant destruction within seconds or minutes) and **delayed** effects (effects are extended to a period from hours to centuries).

8.8.3 Precautions to be taken

- We should keep ourselves informed about the governments plants.
- We should act in accordance with official communication.
- Medical aid should be made available as the effect on human beings are seen through nausea, giddiness, etc.



Activity 2

Collect the images of recent manmade disaster occurred.





MODEL QUESTIONS



Part – I

Choose the correct answer. (1-Mark)

- _____ is commonly used to measure an earthquake's magnitude.
 - Metric Scale
 - Bio Metric Scale
 - Richter scale
 - Non-Metric Scale
- Cyclone is the derivative of the _____ ward cyclos
 - English
 - Greek
 - Spanish
 - French
- Floods causes a risk in epidemics because of _____
 - Heavy Rain
 - Strong Wind
 - Water Logging
 - Cyclone
- _____ are more destructive and harmful to the society than any other weapon.
 - Machine Gun
 - Anti Aircraft Gun
 - Combat Weapons
 - Nuclear Weapons

Part – II

Answer in one or two sentences. (3 Marks)

- List the types of Natural disaster.
- What are the effects of cyclone?
- Write short note on – Oil Spill.
- What do you mean by nuclear disaster?

Part – III

Answer in brief. (5 Marks)

- What is an earthquake? Write its causes.
- What are the effects of flood?

Part – IV

Answer in detail. (10 Marks)

- Write in detail about the precautions to be taken during and after flood.
- Write the causes, effects and precautions to be taken for Human stampede.

1. (c) 2. (b) 3. (c) 4. (d)

Answers



Basic Civil Engineering

PRACTICAL





| | | |
|-------------|--|------------|
| I. | Building drawings (Manual) | 169 |
| | 1. A Single room building | |
| | 2. A Residential building | |
| | 3. A School building | |
| II. | Building drawings (Auto CAD) | 190 |
| | 4. A Single room building – Using Auto CAD | |
| | 5. A Residential building – Using Auto CAD | |
| | 6. A School building – Using Auto CAD | |
| III. | Quantity surveying – Detailed and Abstract Estimate | 211 |
| | 7. Prepare the detailed and abstract estimate for a Compound wall | |
| | 8. Prepare the detailed and abstract estimate for a Single room building | |
| IV. | Surveying | 217 |
| | 9. Fly Levelling – Closed Traverse. | |
| | 10. Fly Levelling – Open Traverse. | |

INTRODUCTION

A building is a living place surrounded by walls and covered by roof for the purpose of keeping out rain, sun, wind and snow. It may be a bungalow, apartment, school, hospital, shopping complex, industry, residential building etc. Any building essentially comprises of three parts namely foundation, super structure and roof. Before construction the civil engineer has to plan and prepare the building drawing with all details.

The main aim of building drawing is to give sufficient informations by the designer to the construction engineer. In order to give sufficient information about the building the following views are generally drawn:

- A. Plan
- B. Elevation
- C. Section

A. PLAN

The building is imagined to be cut by a horizontal plane at the sill level of the window. The upper portion is removed. Now building is seen from top. A projection of the remaining portion of the building on a horizontal plane is known as the plan.

B. ELEVATION

It is the front view of a building. Imagine to stand in front of it. Whatever the portion of the building is visible above the ground level, take its first angle projection on a vertical plane behind the building known as the elevation.

C. SECTION

The building is imagined to be cut by a vertical plane in order to show the internal details such as details of foundation, flooring, doors, windows, ventilators, thickness of walls, lintels, roof, parapet wall, sunshade, etc. Arrows

at the extreme ends of the section plane or planes show the directions in which these details are required. The details drawn and marked on a vertical plane, after removing the part of the building behind the cut section is known as the section.

TERMINOLOGY

BUILDING MATERIALS

1. **MASONRY:** According to the type of material used for construction, it is called as stone masonry, brick masonry or concrete masonry.
2. **CEMENT MORTAR (C.M):** It is a substance produced from prescribed proportions of cement, sand and water which generally sets hard after mixing and binds the building materials together.
3. **CEMENT CONCRETE (C.C):** It is mixture of cement, sand (Fine aggregate), jelly (coarse aggregate) and water. Concrete mix of 1:1½:3 means 1 part by weight of cement, 1½ parts of sand and 3 parts of jelly are used to form the Mix.
4. **PLAIN CEMENT CONCRETE (PCC):** A plain cement concrete is the concrete without any reinforcement. It is usually referred as cement concrete.
5. **REINFORCED CEMENT CONCRETE (RCC):** It is the concrete reinforced by mild steel or twisted bars.

BUILDING COMPONENTS:

1. **FOUNDATION:** It is the portion of a building below the ground level (G.L). It transmits the load coming from the superstructure to the ground.
2. **FOOTINGS:** Footings are stepped courses in foundation. These are

constructed in brick masonry or stone masonry or concrete under the walls of columns for distributing the load of the superstructure on to a larger area of subsoil.

3. **BASEMENT:** It is the lower storey of a building, below or partly below the ground level.
4. **SUPER STRUCTURE:** It is the portion of the building above the ground level.
5. **PLINTH:** It is the portion of the structure between the ground level and the floor level. The level of the floor is usually known as the plinth level. Plinth height may be 300mm to 600mm, but 450mm is more common. For water logging prone areas, the plinth height will be 600mm.
6. **FLOORING:** The flooring will be generally in plain cement concrete (P.C.C) 1:4:8 of about 130mm thick, plastered smooth with cement mortar 1:3 of 20mm thick. This may be finished with tiles, marbles etc.
7. **DAM PROOF COURSE (DPC):** It is a continuous layer of an impervious material such as bitumen, slate or rich concrete provided at the plinth level beneath the walls to prevent the entry of moisture into the building through basement.
8. **MASONRY WALLS:** Masonry walls may be of either brick or stone. Actual size of Modular brick is 190

x 90 x 90mm. The thickness of a single brick wall including plastering is 200mm and of 1 ½ brick wall is 300mm.

9. **DOORS, WINDOWS AND VENTILATORS:** The size of door to be adopted for a room depends basically upon the functional requirement of the room. Commonly adopted sizes of doors for different types of buildings are given below.
10. **SILL:** It is the bottom horizontal frame of a window.
11. **LINTEL:** It is defined as a horizontal member provided on the top of door and window openings to support the brick work over door and window opening.
12. **SUNSHADE:** It is a projection from the wall, provided above the door or window for the protection against the sunrays and rain.
13. **ROOF:** It is a flat or inclined structural member provided as a cover to the building. It is used to protect the building from weathering actions namely rain, sun, wind, etc. Generally it is constructed of RCC of about 125mm thick.
14. **CEILING:** The lower level of the roof slab exposed to the room is known as ceiling. Sometimes, special materials will be used below the concrete roof to improve the appearance of the ceiling, which is known as false ceiling.

| Sl. No. | TYPES OF BUILDINGS | SIZE OF DOORS in 'mm' |
|---------|---|------------------------------|
| 1 | Public buildings like office, school, hospital, library, etc. | 1200 x 2100, 1500x2100, etc. |
| 2 | Residential buildings | 1100x2100, 900x200, etc. |
| 3 | Door for bath and water closet | 800x200, etc. |



- 15. WEATHERING COURSE:** It is about 100mm thick brick jelly lime concrete, provided at the top of the roof slab to protect the slab from weathering actions sunshine, rain, etc.
- 16. PARAPET WALL:** It is a short wall of about 450 to 900mm built over the roof all round the building.
- 17. COPING:** It is a projection on the top of the parapet wall on outside or both sides to throw off rainwater.
- 18. STEPS:** Steps are generally in brick work in cement mortar 1:5 laid on PCC base. Rise and Tread of a step are 150 to 200mm and 230 to 300mm respectively.



I. BUILDING DRAWINGS (MANUAL)

1) A SINGLE ROOM BUILDING

The following line sketch shows the internal dimensions of A SINGLE ROOM BUILDING. Draw to a scale of 1:50, 1:00 the following views:

- A) Plan
- B) Section on AB
- C) Elevation

| | SPECIFICATIONS |
|-------------------|---|
| a) FOUNDATION | Depth of foundation is 1 m below natural ground level. The concrete base course is 1 m wide and 0.3 m thick in PCC of 1:4:8 mix. |
| b) FOOTING | A footing of RR masonry in CM 1:5 having width 0.6m and depth 0.7m will be provided over the base course layer. |
| c) BASEMENT | The basement will be of RR masonry in CM 1:5 and of height 0.45m above the natural ground level. The thickness of plinth wall is 0.45m and a damp proof course 0.02m thick in CM 1:3 will be provided around the building. |
| d) FLOORING | Over 0.340m depth of sand filling, flooring of 0.110m thick in CC 1:4:8 finished with granite tiles is provided. |
| e) SUPERSTRUCTURE | The thickness of walls above plinth level is 0.23 m in brick work using CM 1:5. The height of the parapet wall is 0.6m above the roof top level. Lintel – cum – sunshade will be provided over the door and window openings. Thickness and bearing of RCC lintel in CC 1:1.5:3 will be 0.15m. The projection of sunshade will be 0.45m from the wall. The thickness is 0.08m at support and 0.05m at free end. Ceiling height will be 3m above the floor level. |
| f) ROOFING | Roofing will be of flat RCC in CC 1:1.5:3, 0.12m thick. A weathering course of 0.1m thick is provided over the roof slab with sufficient slope to drain rainwater. |
| g) STEPS | Tread = 0.3m. Rise = 0.15m. |

REFERENCE

- D - Panelled Wooden Door - 1.2 m x 2.10 m
- W - Panelled Wooden Window - 1.2 m x 1.40 m
- V - Glazed Ventilator - 0.6 mx0.45m

Assume any other data suitably, if necessary.

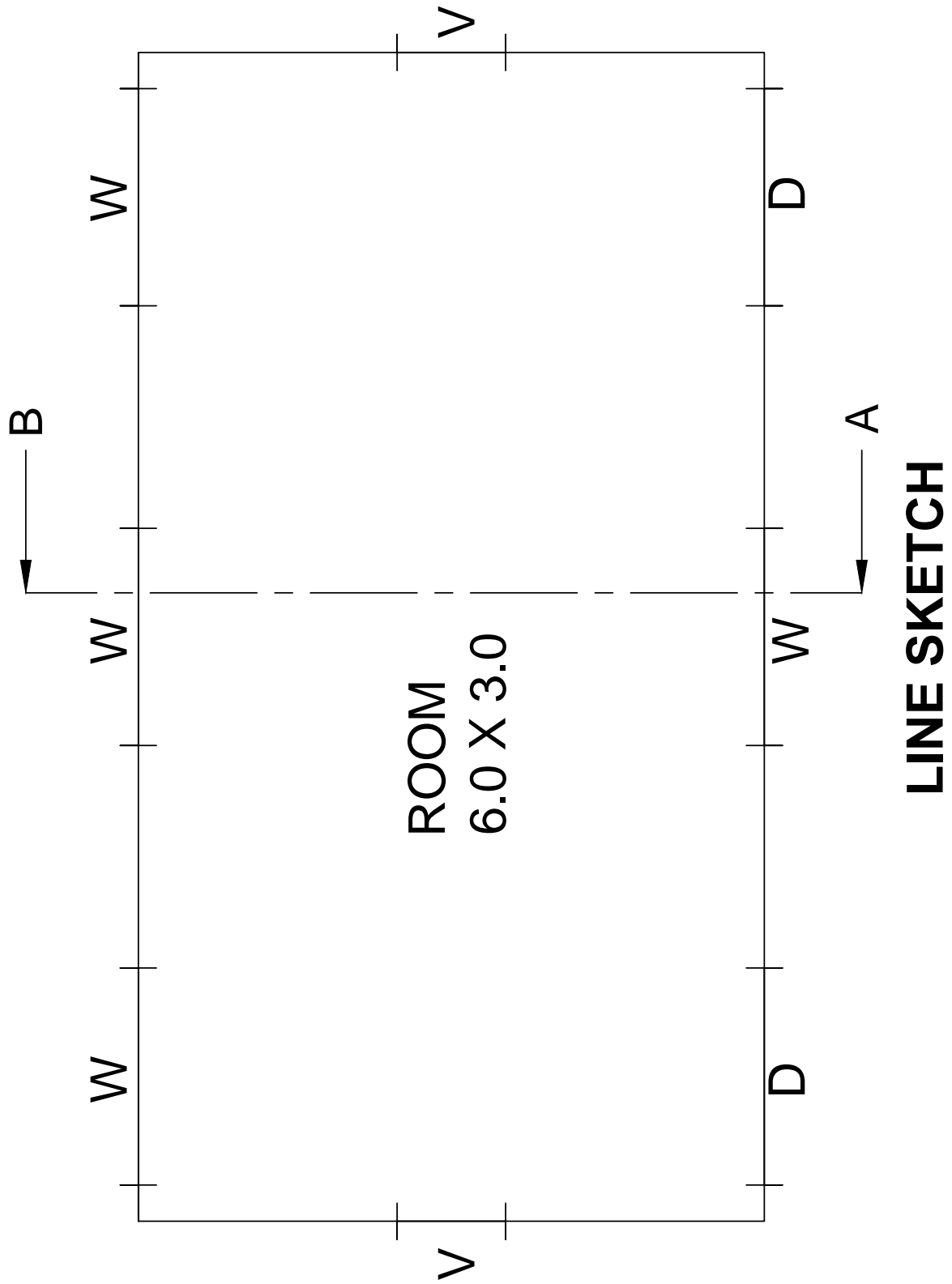

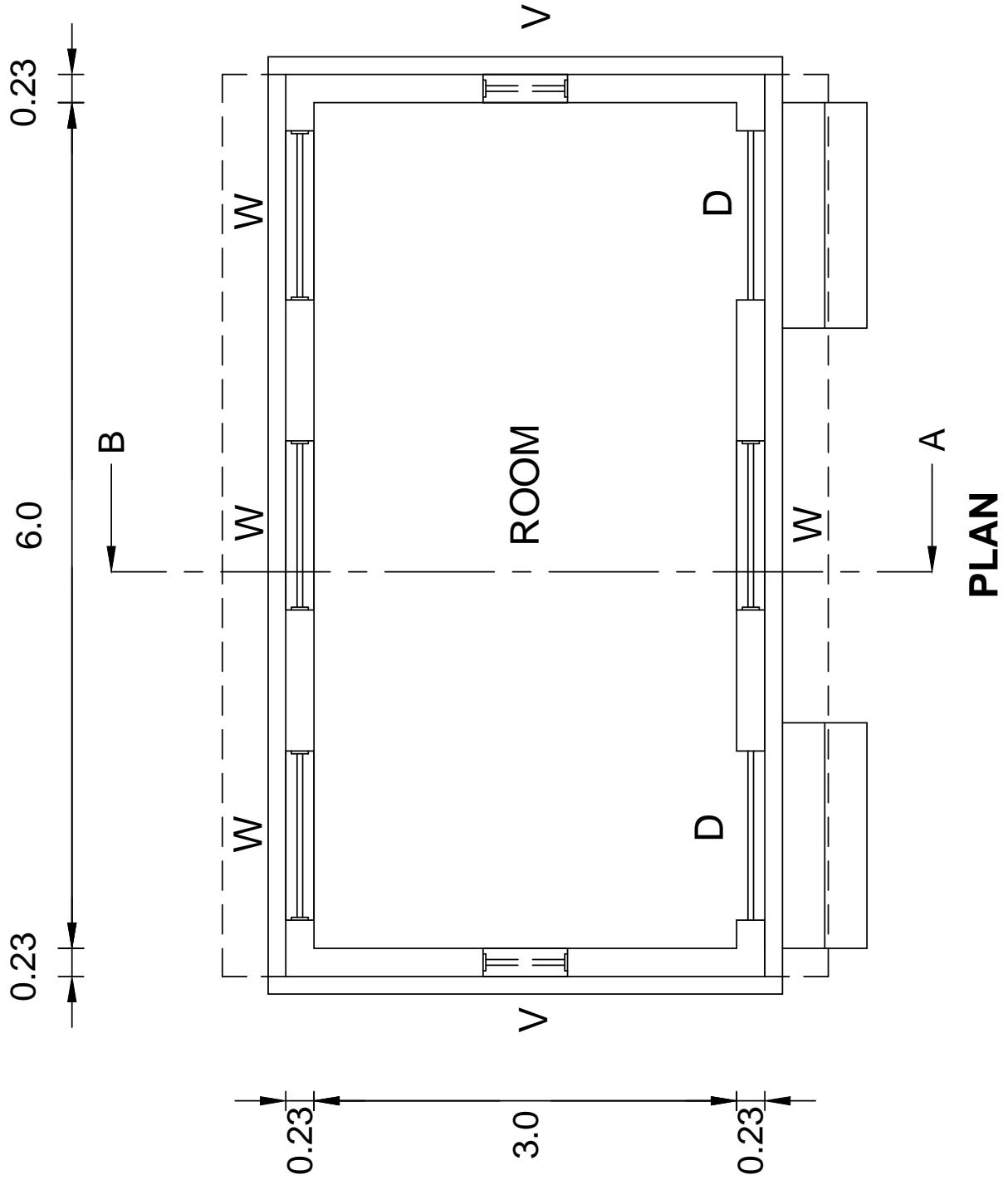

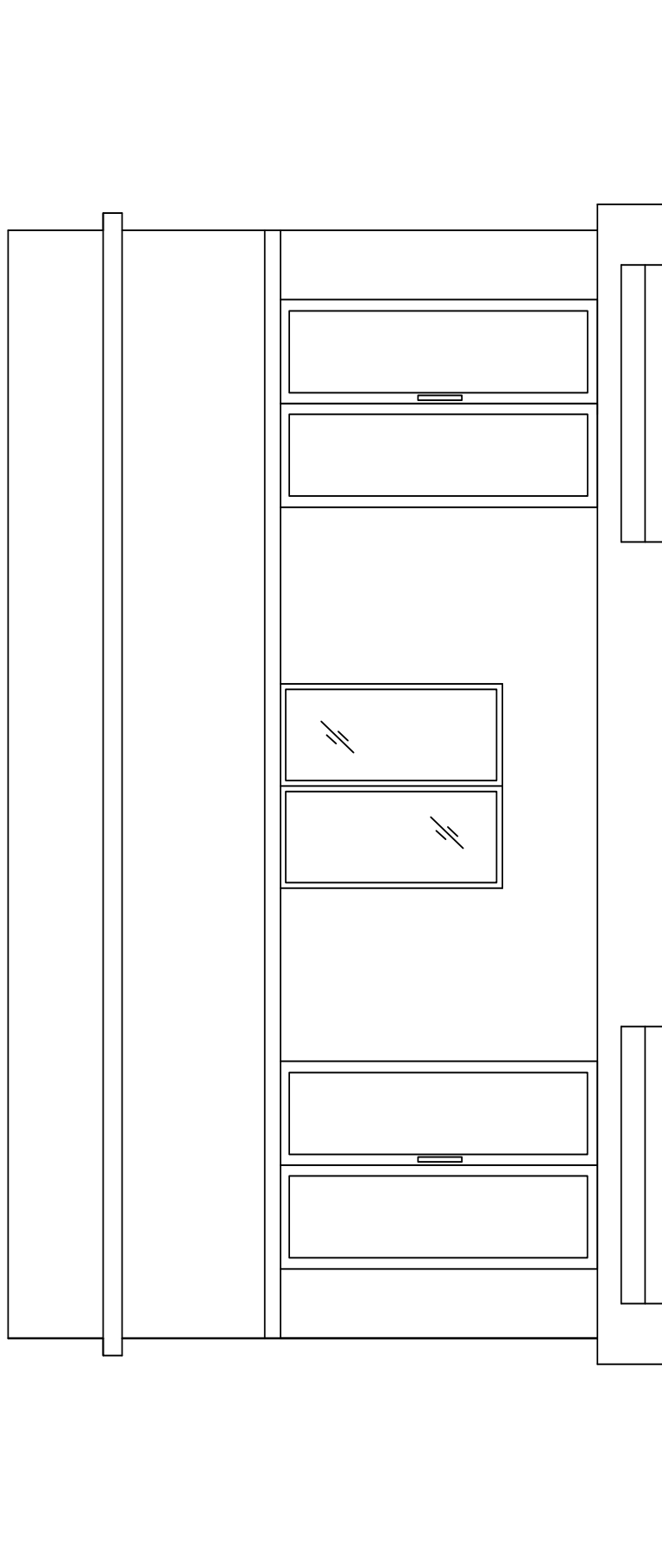

ELEVATION



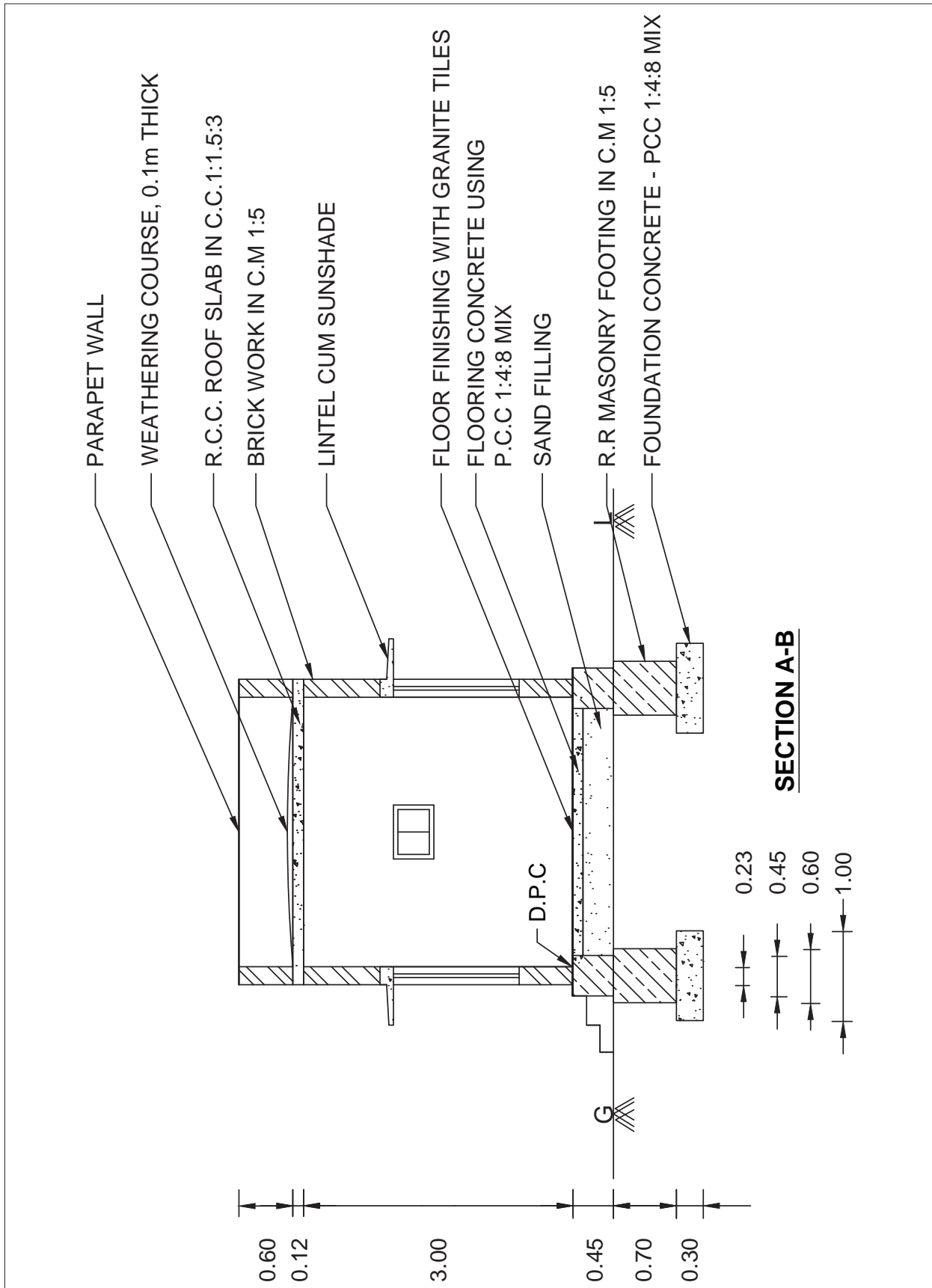

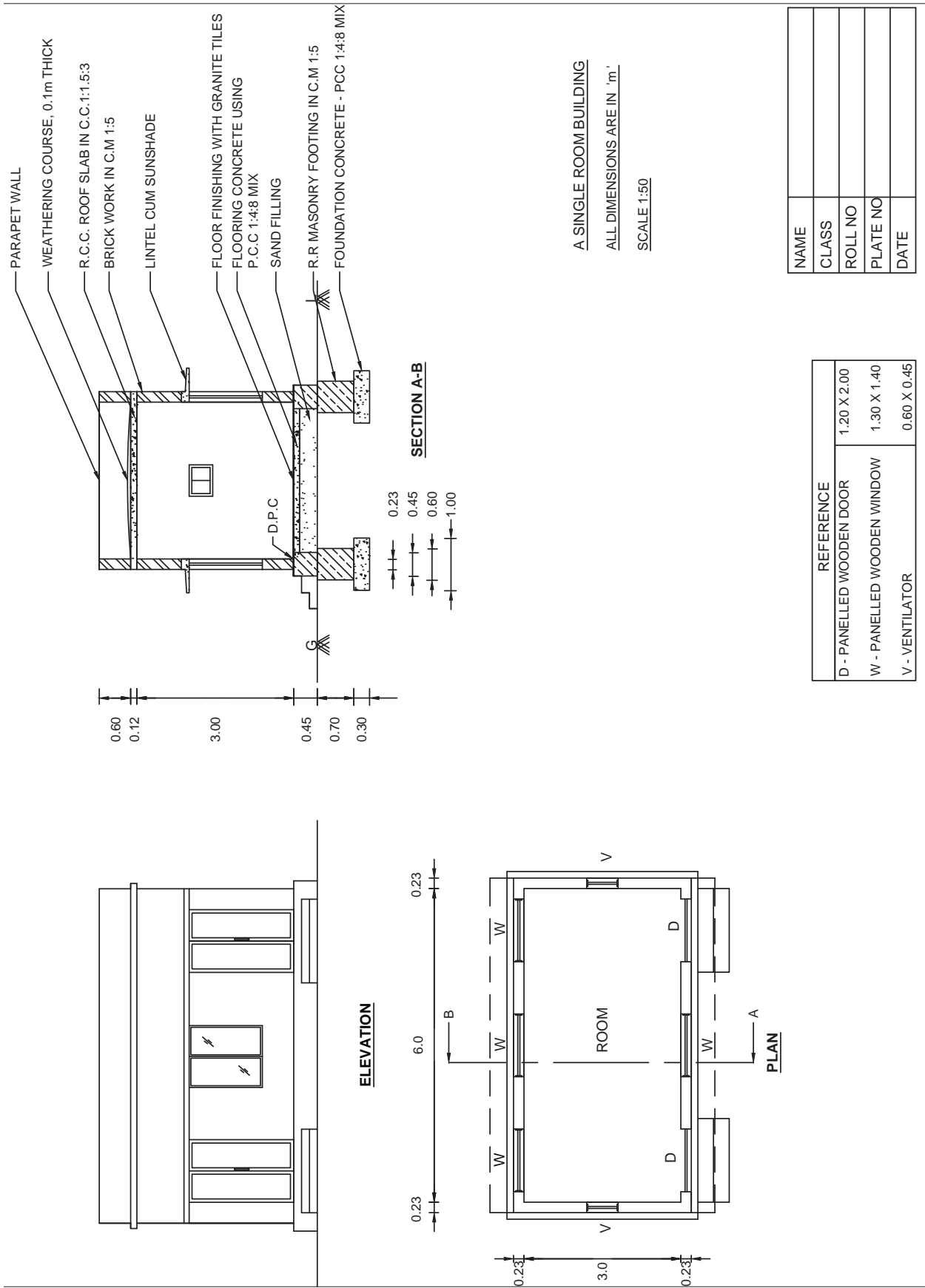

| | |
|----------|--|
| NAME | |
| CLASS | |
| ROLL NO | |
| PLATE NO | |
| DATE | |

| | |
|----------------------------|-------------|
| REFERENCE | |
| D - PANELLED WOODEN DOOR | 1.20 X 2.00 |
| W - PANELLED WOODEN WINDOW | 1.30 X 1.40 |
| V - VENTILATOR | 0.60 X 0.45 |

2) A RESIDENTIAL BUILDING

The following line sketch shows the internal dimensions of A RESIDENTIAL BUILDING. Draw to a scale of 1:50 / 1:100, the following views:

- A) Plan
- B) Section on AB
- C) Elevation

| | SPECIFICATIONS |
|-------------------|--|
| a) FOUNDATION | Depth of foundation is 1.2 m below natural ground level. The concrete base course is 1.2 m wide and 0.3 m thick in PCC of 1:4:8 mix |
| b) FOOTING | Isolated footings as per design in RCC 1:1.5:3 will be provided in appropriate places. The breadth and thickness of footing will be 0.90 m and 0.45 m respectively. Over the footing, RCC column 0.23 x 0.23m size are raised up to the grade beam level. |
| c) GRADE BEAM | A beam of size 0.23 x 0.30 m is provided as per the structural design around the building up to the ground level. |
| d) BASEMENT | The basement will be of brick masonry in CM 1:5 and of height 0.6m above the Grade beam. The thickness of plinth wall is 0.23m and a damp proof course 0.02m thick in CM 1:3 which is mixed with 5% crude oil will be provide around the building. |
| e) FLOORING | Over 0.450m depth of sand filling, flooring of 0.15m thick in CC 1:4:8 mix finished with marble stone is provided. |
| f) SUPERSTRUCTURE | RCC columns 0.23 x 0.23m are raised above the Grade beam upto roof level in correct sequence. The thickness of walls above plinth level is 0.23 in brick work using CM 1:5. The height of the parapet wall is 0.9 m above the roof top level. Lintel – cum – sunshade will be provided over the door and window openings. Thickness and bearing of RCC lintel in CC 1:1.5:3 will be 0.15m. The projection of sunshade will be 0.45m from the wall. The thickness is 0.08m at support and 0.05m at free end. Ceiling height will be 3m above the floor level. |
| g) ROOFING | Roofing will be of flat RCC in CC 1:1.5:3, 0.12m thick. A weathering course of 0.1m thick is provided over the roof slab with sufficient slope to drain rainwater. |
| h) STEPS | Tread = 0.3m. Rise = 0.15m. |



REFERENCE

| | | |
|-----|------------------------|------------------|
| D - | Panelled Wooden Door | - 1.2 m x 2.10 m |
| D1 | Panelled Wooden Door | - 0.90 m x 2.10m |
| D2 | PVC door | - 0.75 x 2.10 m |
| W - | Panelled Wooden Window | - 1.2 m x 1.40 m |
| V - | Glazed Ventilator | - 0.6 mx0.45m |

Assume any other data suitably, if necessary.



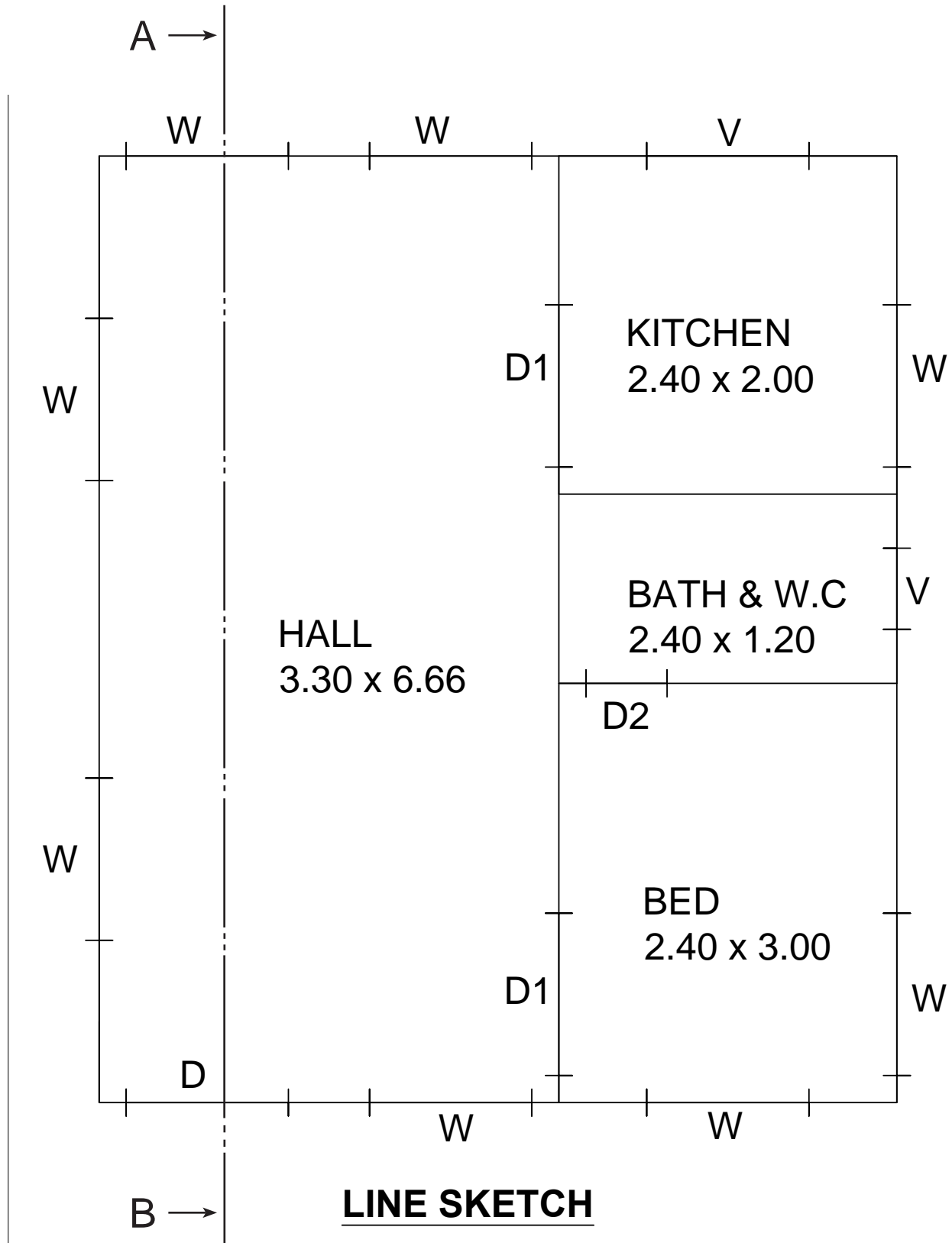

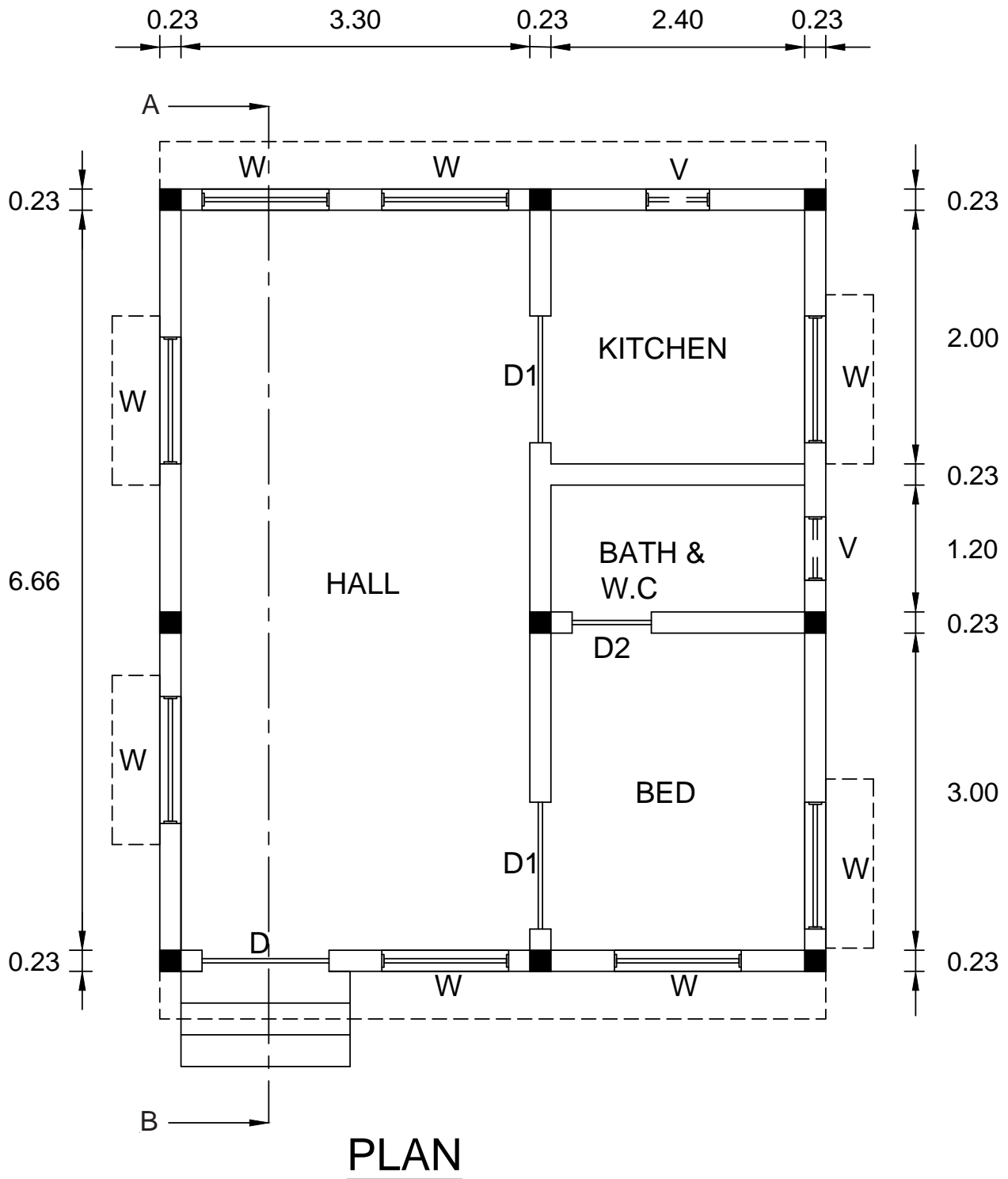

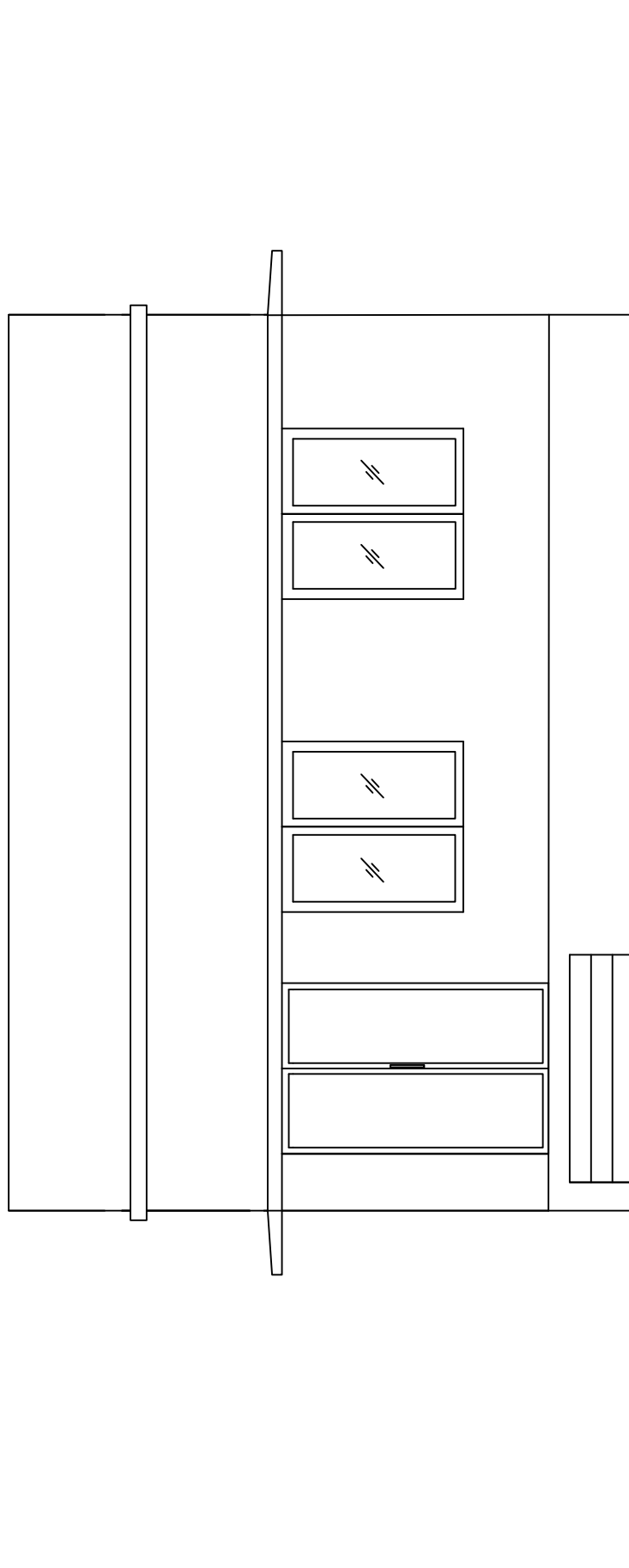

ELEVATION



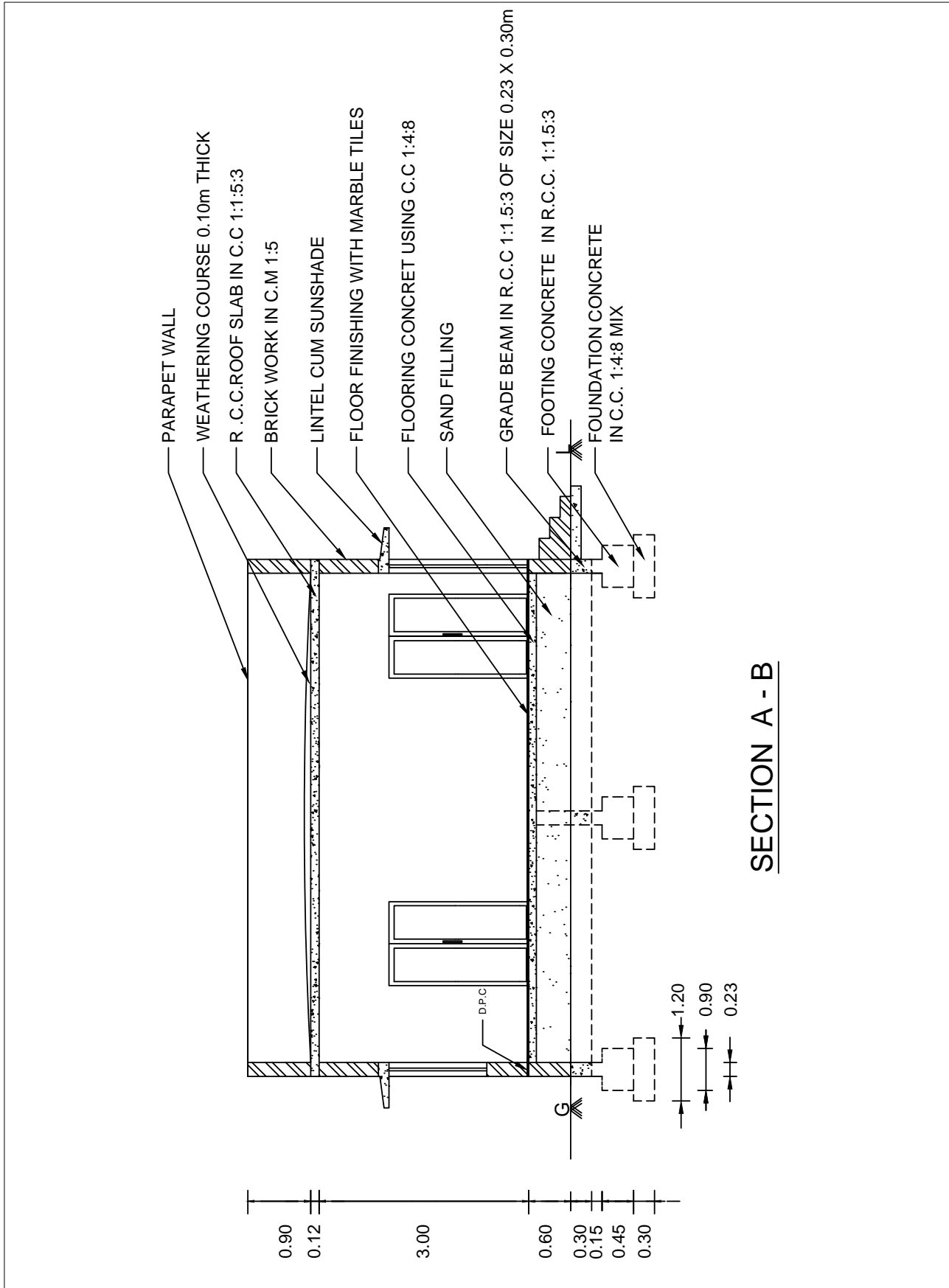

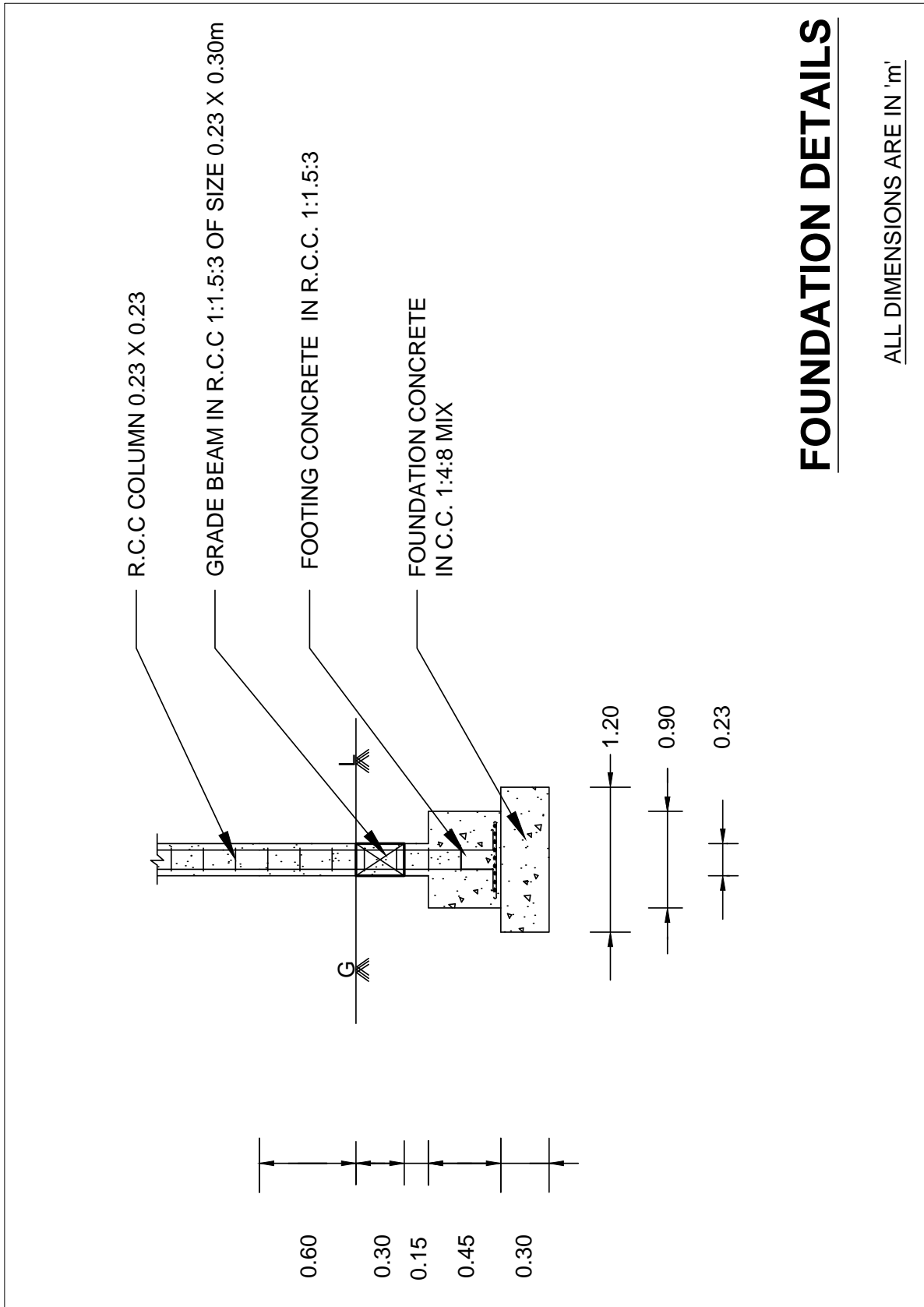

FOUNDATION DETAILS

ALL DIMENSIONS ARE IN 'm'

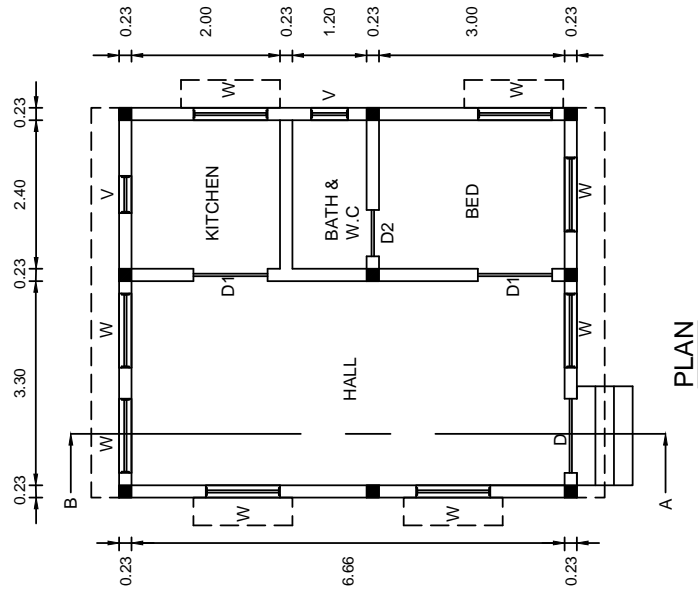
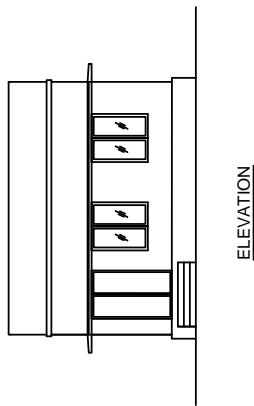
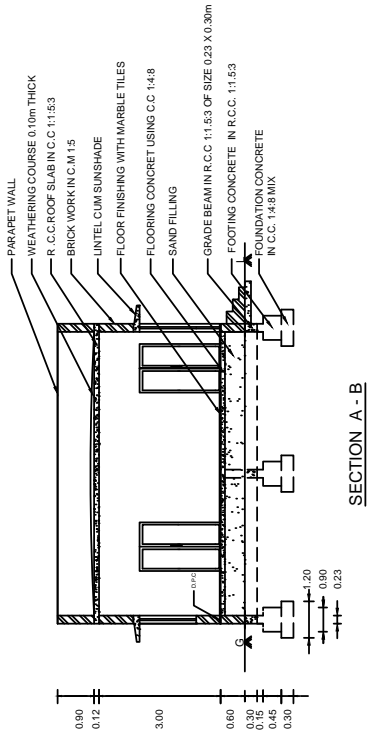

A RESIDENTIAL BUILDING

ALL DIMENSIONS ARE IN 'm'

SCALE 1:100

| REFERENCE | DESCRIPTION |
|-----------|------------------------|
| D1 | PANELLED WOODEN DOOR |
| D2 | PVC DOOR |
| D1 | PANELLED WOODEN DOOR |
| W | PANELLED WOODEN WINDOW |
| V | VENTILATOR |

| NAME | CLASS | ROLL NO | PLATE NO | DATE |
|------|-------|---------|----------|------|
| | | | | |
| | | | | |
| | | | | |
| | | | | |

3) A SCHOOL BUILDING

The following line sketch shows the internal dimensions of A SCHOOL BUILDING. Draw to a scale of 1:50/1:100, the following views:

- A) Plan
- B) Section on AB
- C) Elevation

| | <u>SPECIFICATIONS</u> |
|-------------------|---|
| a) FOUNDATION | Depth of foundation is 1.50 m below natural ground level. The concrete base course is 1.2 m wide and 0.3 m thick in PCC of 1:4:8 mix. |
| b) FOOTING | Isolated footings as per design in RCC 1:1.5:3 will be provided in appropriate places. The breadth and thickness of footing will be 1.00 m and 0.45 m respectively. Over the footing, RCC column 0.23 x 0.23m (or) 0.23 x 0.45 m size are raised upto the grade beam level . |
| c) GRADE BEAM | A beam of size 0.23 x 0.45 m is provided as per the structural design around the building up to the ground level. |
| d) BASEMENT | The basement will be of brick masonry in CM 1:5 and of height 0.45m above the Grade beam. The thickness of plinth wall is 0.23m and a damp proof course 0.02m thick in CM 1:3 which is mixed with 5% crude oil will be provide around the building. |
| e) FLOORING | Over 0.30m depth of sand filling, flooring of 0.15m thick in CC 1:4:8 finished with tiles is provided. |
| f) SUPERSTRUCTURE | RCC columns 0.23 x 0.23 m and 0.23 x 0.45 m are raised in right places above the Grade beam upto roof level in correct sequence. The thickness of walls is 0.23 in brick work using CM 1:5. The height of the parapet wall is 0.60 m above the roof top level. Lintel – cum – sunshade will be provided over the door and window openings. Thickness and bearing of RCC lintel in CC 1:1:5:3 will be 0.15m. The projection of sunshade will be 0.45m from the wall. The thickness is 0.08m at support and 0.05m at free end. Ceiling height will be 3m above the floor level. |
| g) ROOFING | Roofing will be of flat RCC in CC 1:1.5:3, 0.12m thick. A weathering course of 0.1m thick is provided over the roof slab with sufficient slope to drain rainwater. |
| h) STEPS | Tread = 0.3m. Rise = 0.15m. |

REFERENCE

D - Panelled Wooden Door - 1.2 m x 2.10 m

W - Panelled Wooden Window - 1.2 m x 1.40 m

Assume any other data suitably, if necessary.

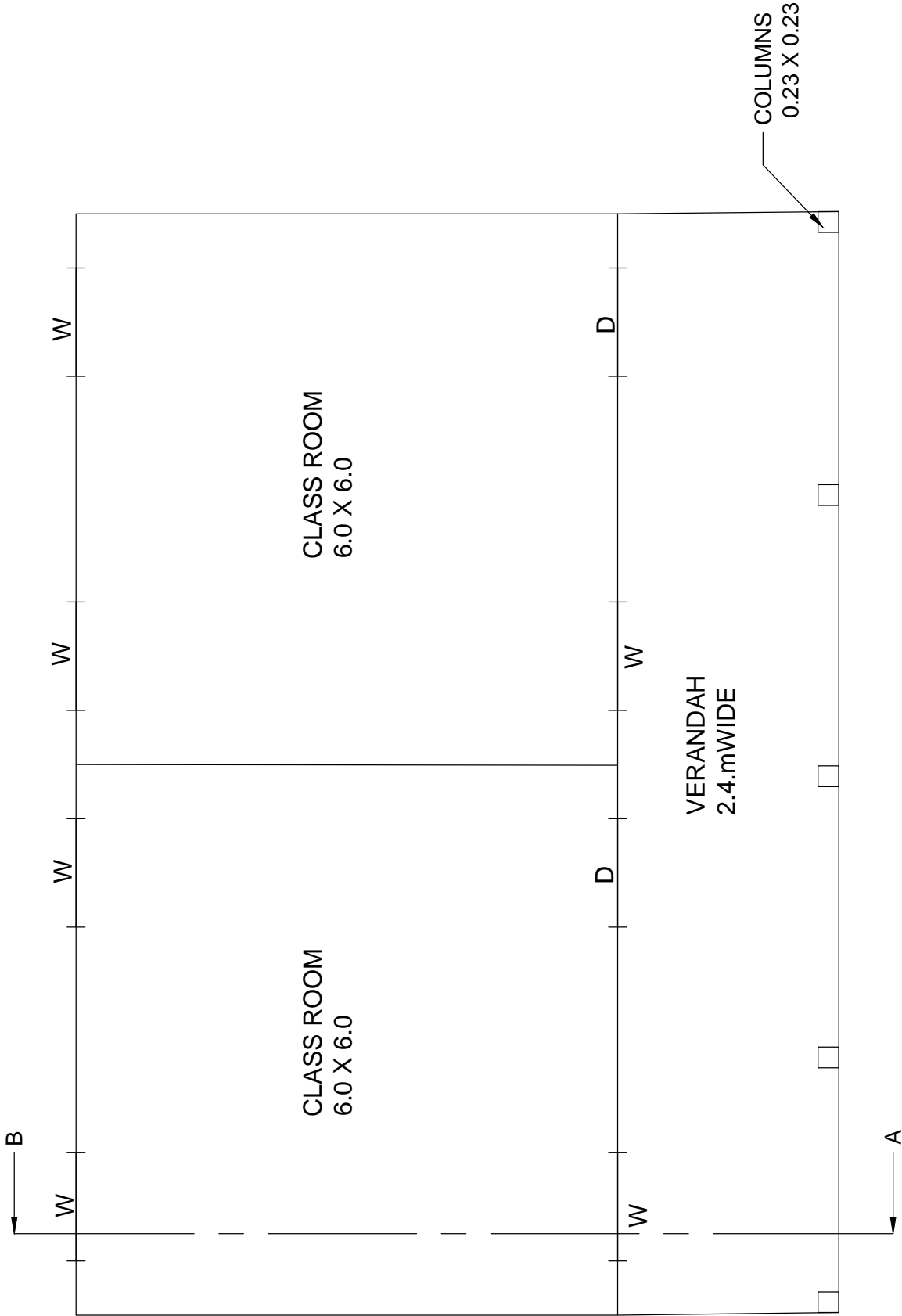

LINE SKTECH

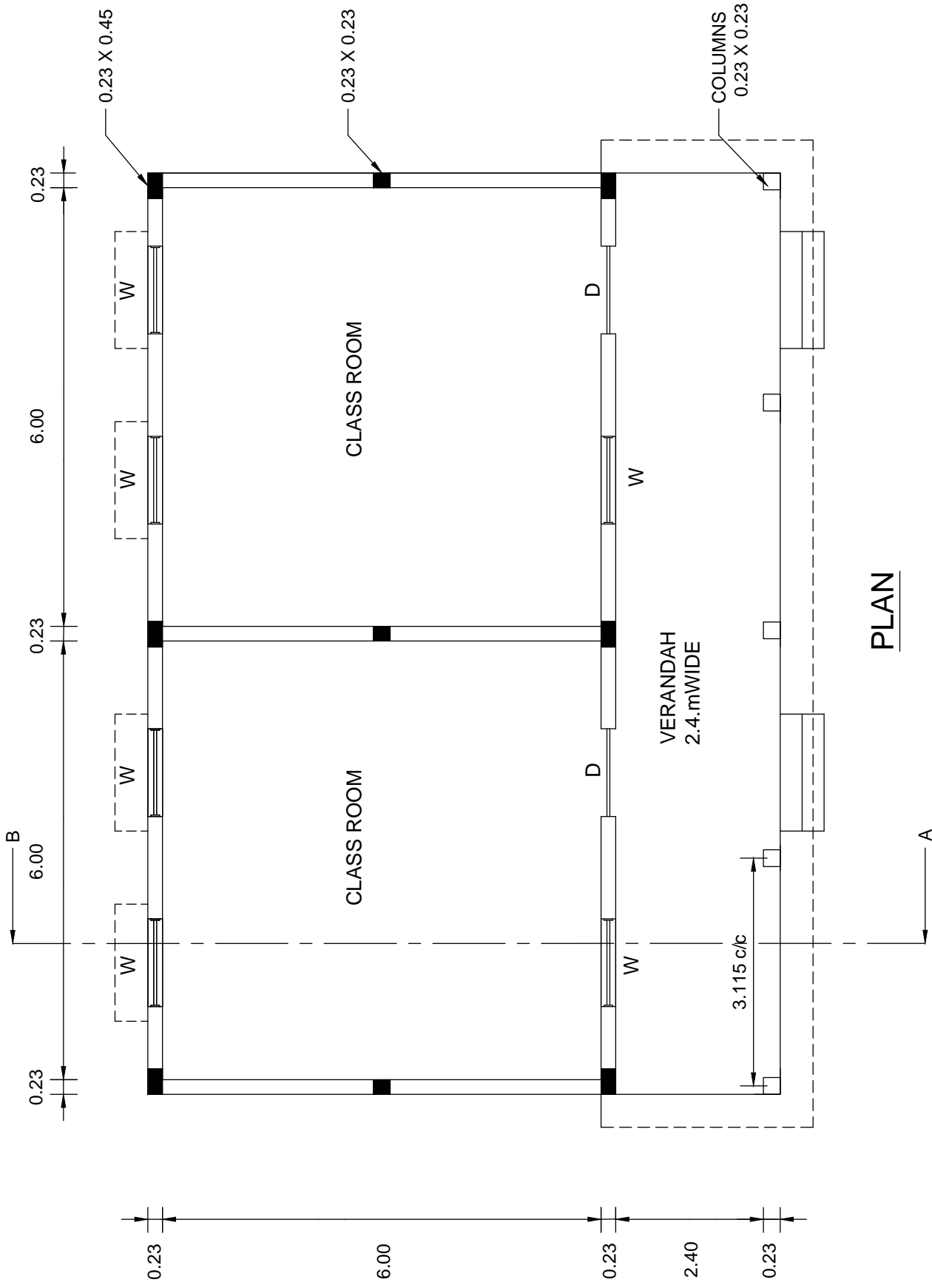

PLAN

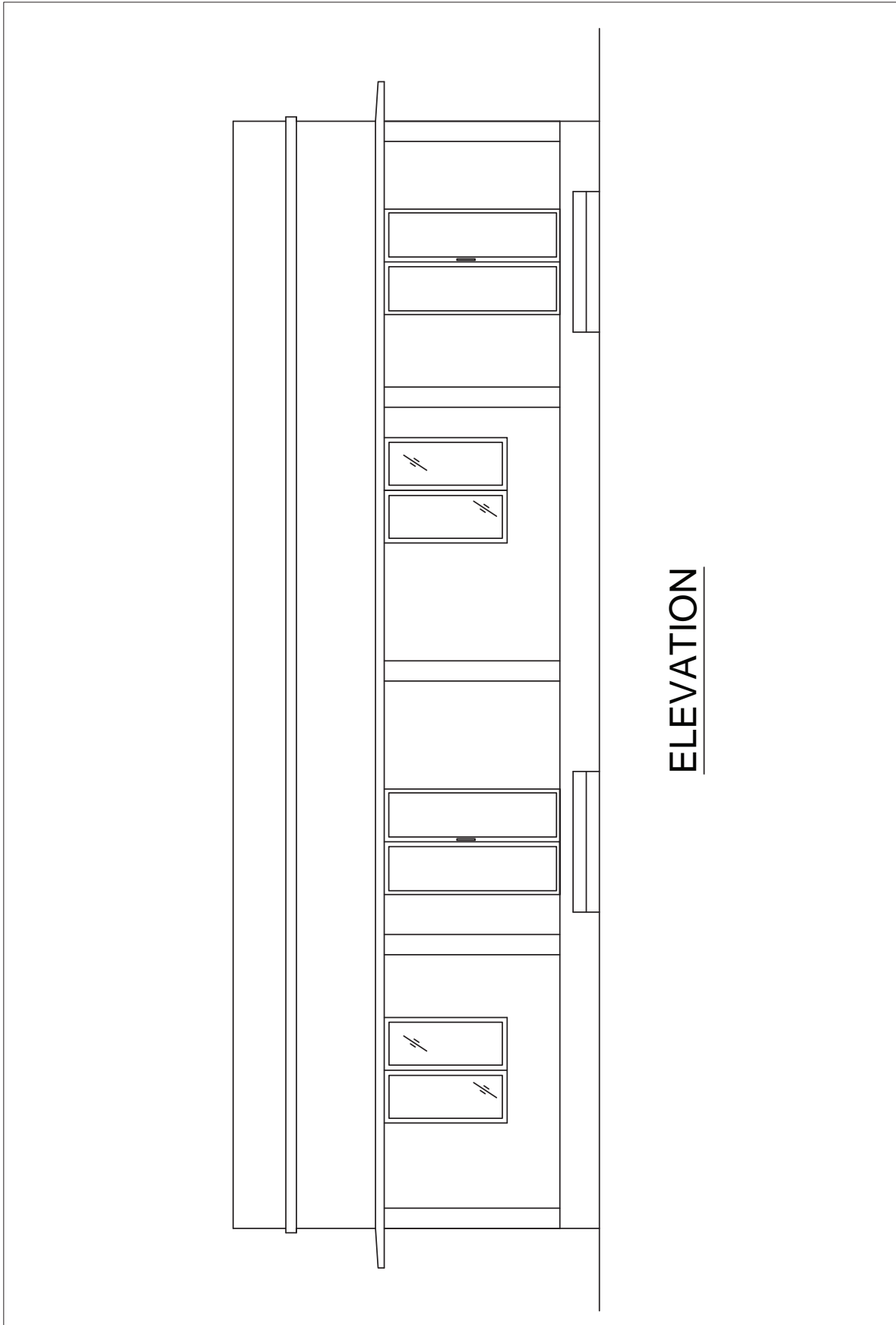

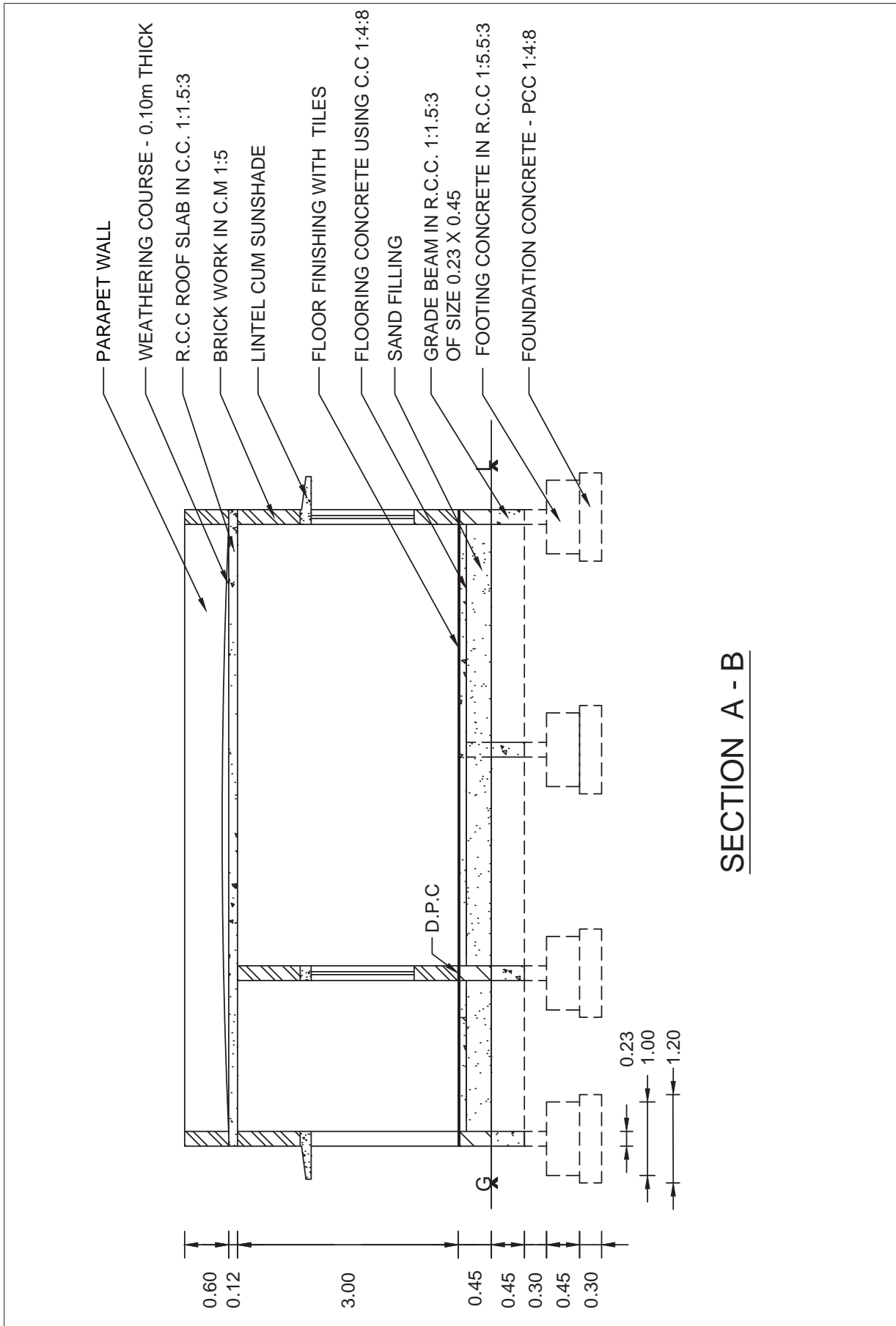

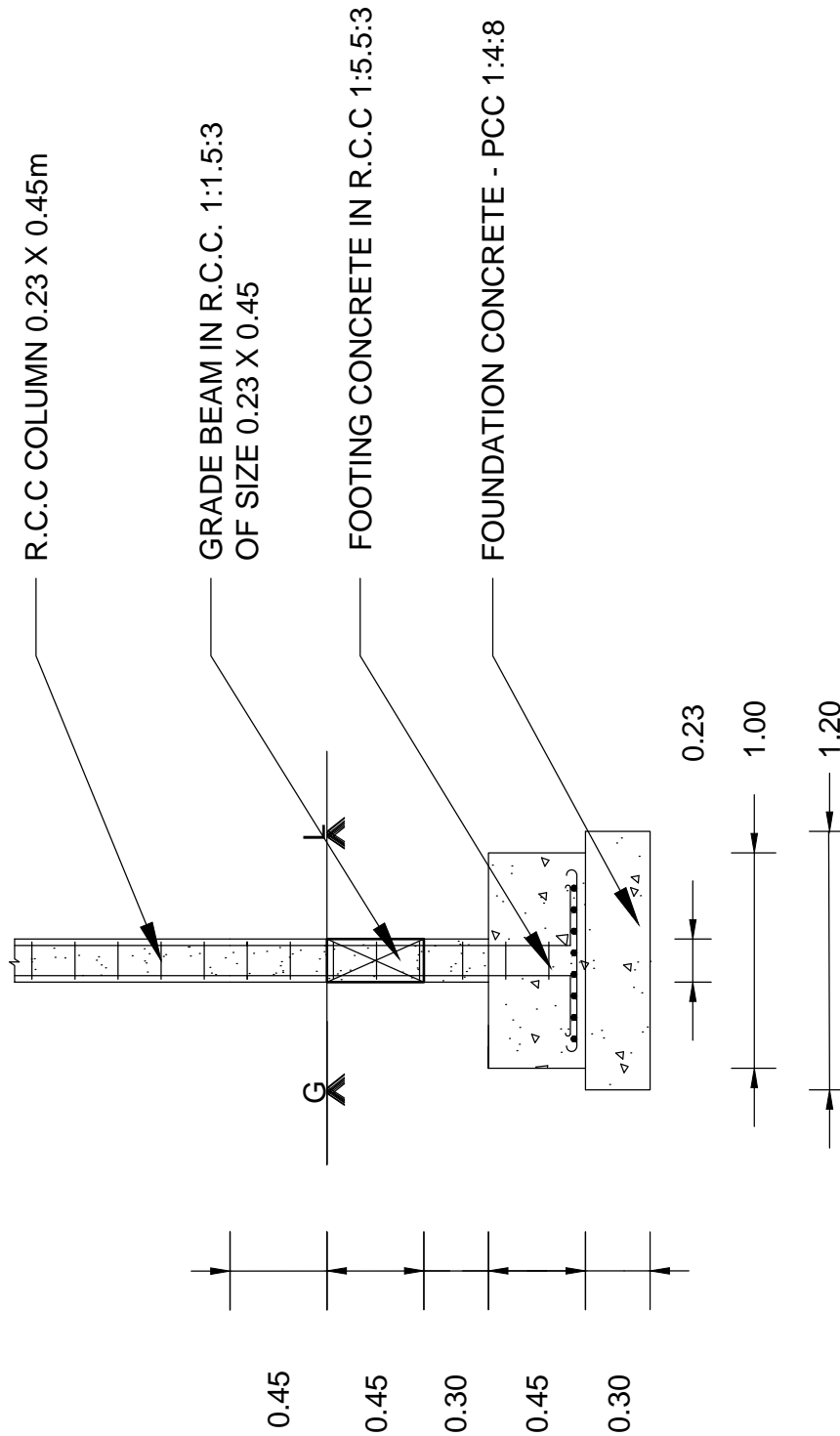

FOUNDATION DETAILS

ALL DIMENSION ARE IN 'm'

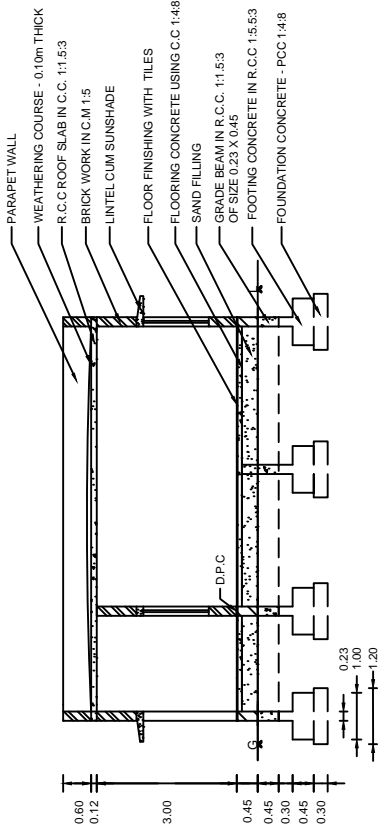

SECTION A - B

A SCHOOL BUILDING

ALL DIMENSION ARE IN 'm'

SCALE 1:100

| | |
|----------|--|
| NAME | |
| CLASS | |
| ROLL NO | |
| PLATE NO | |
| DATE | |

| REFERENCE | |
|------------------------|-------------|
| PANELLED WOODEN DOOR | 1.20 X 2.00 |
| PANELLED WOODEN WINDOW | 1.20 X 1.40 |

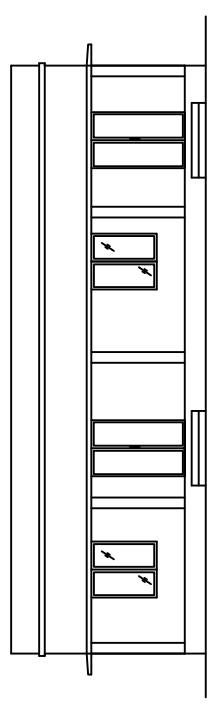

ELEVATION

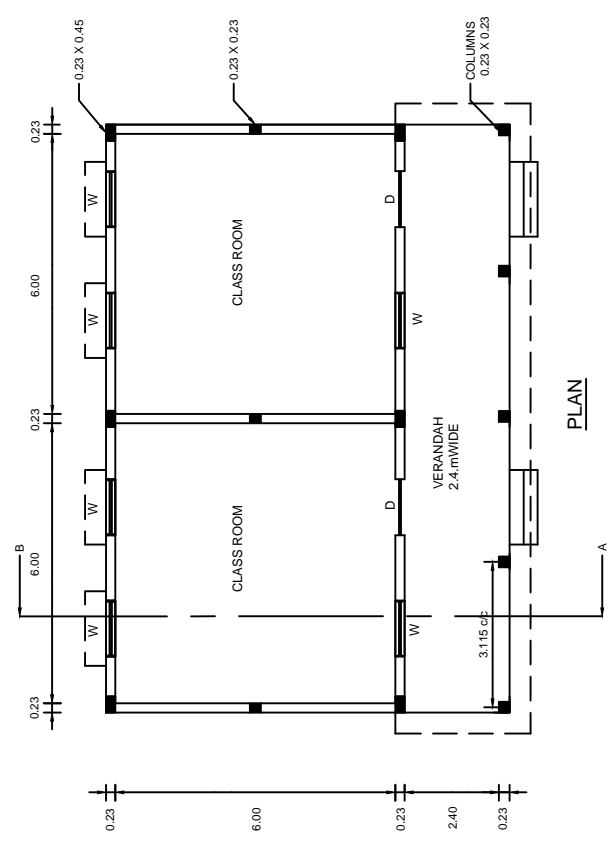

PLAN

II. BUILDING DRAWINGS (AUTOCAD)

4) A SINGLE ROOM BUILDING – Using AUTO CAD

The following line sketch shows the internal dimensions of A SINGLE ROOM BUILDING. Draw to a scale of 1:50 / 1:100, the following views: using AUTO CAD

- A) Plan
- B) Section on AB
- C) Elevation

| | SPECIFICATIONS |
|-------------------|---|
| a) FOUNDATION | Depth of foundation is 1 m below natural ground level. The concrete base course is 1 m wide and 0.3 m thick in PCC of 1:4:8 mix. |
| b) FOOTING | A footing of RR masonry in CM 1:5 having width 0.6m and depth 0.7m will be provided over the base course layer. |
| c) BASEMENT | The basement will be of RR masonry in CM 1:5 and of height 0.45m above the natural ground level. The thickness of plinth wall is 0.45m and a damp proof course 0.02m thick in CM 1:3 will be provided around the building. |
| d) FLOORING | Over 0.340m depth of sand filling, flooring of 0.110m thick in CC 1:4:8 finished with granite tiles is provided. |
| e) SUPERSTRUCTURE | The thickness of walls above plinth level is 0.23 m in brick work using CM 1:5. The height of the parapet wall is 0.6m above the roof top level. Lintel – cum – sunshade will be provided over the door and window openings. Thickness and bearing of RCC lintel in CC 1:1.5:3 will be 0.15m. The projection of sunshade will be 0.45m from the wall. The thickness is 0.08m at support and 0.05m at free end. Ceiling height will be 3m above the floor level. |
| f) ROOFING | Roofing will be of flat RCC in CC 1:1.5:3, 0.12m thick. A weathering course of 0.1m thick is provided over the roof slab with sufficient slope to drain rainwater. |
| g) STEPS | Tread = 0.3m. Rise = 0.15m. |

REFERENCE

- D - Panelled Wooden Door - 1.2 m x 2.10 m
- W - Panelled Wooden Window - 1.2 m x 1.40 m
- V - Glazed Ventilator - 0.6 mx0.45m

Assume any other data suitably, if necessary.

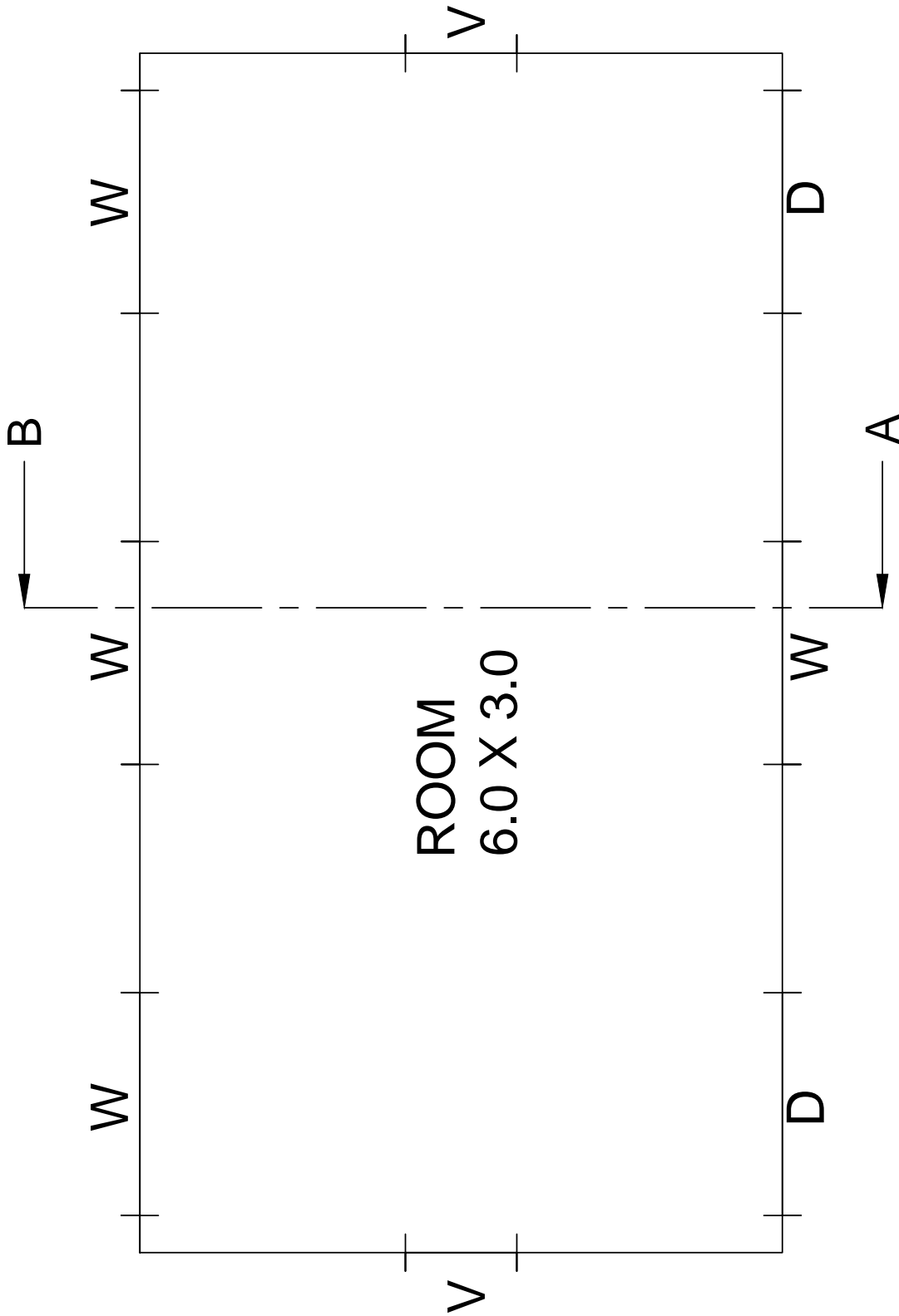

LINE SKETCH

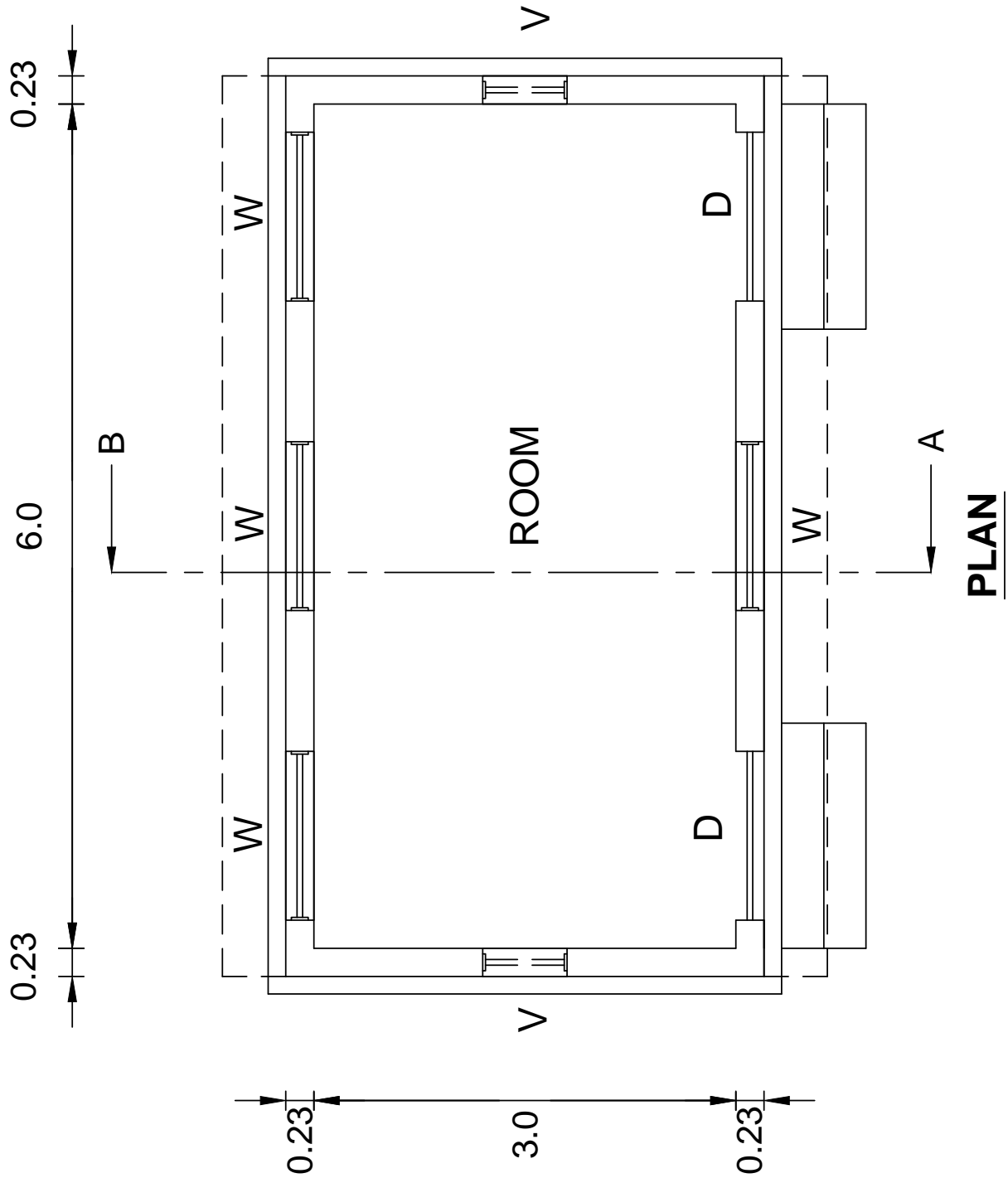

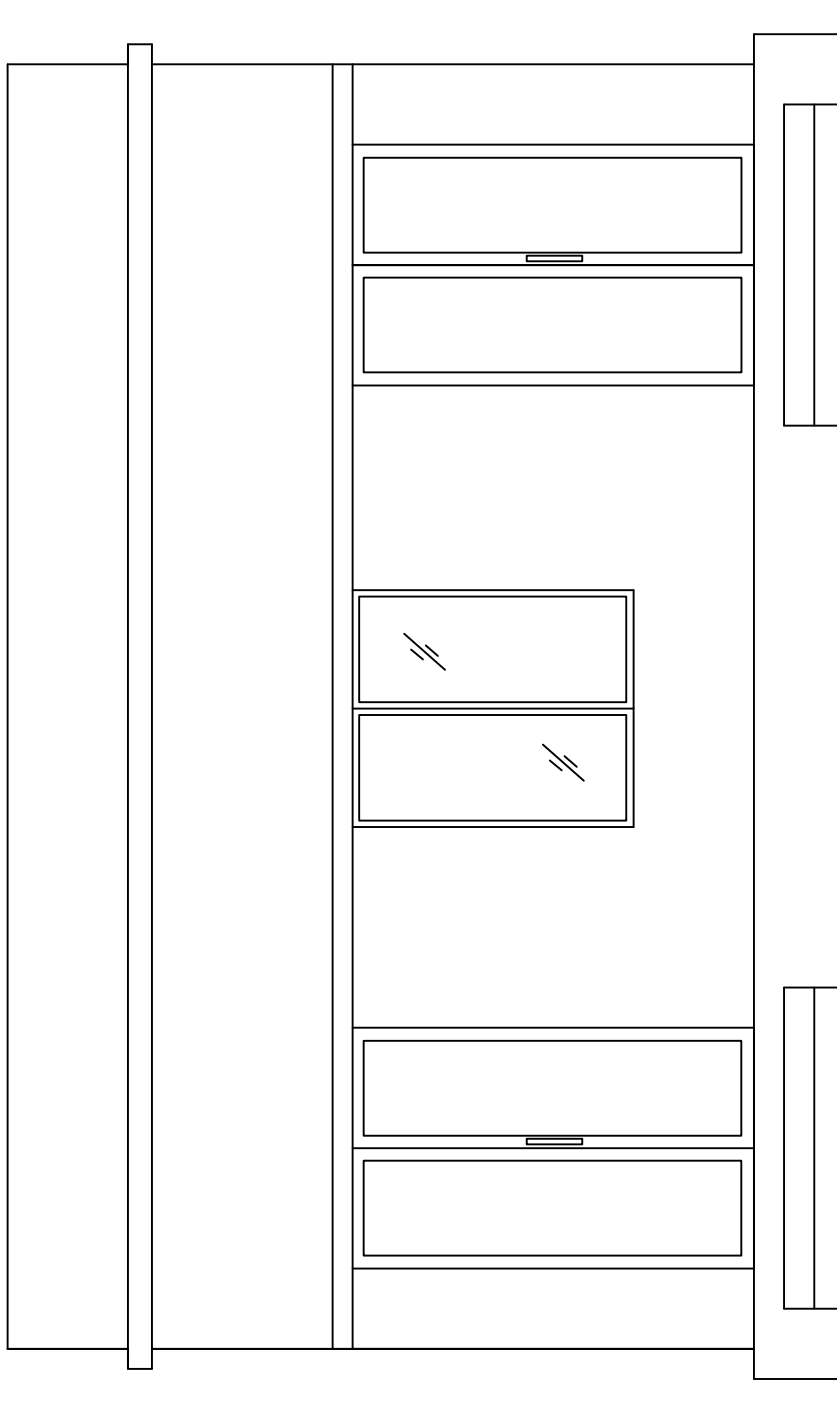

ELEVATION



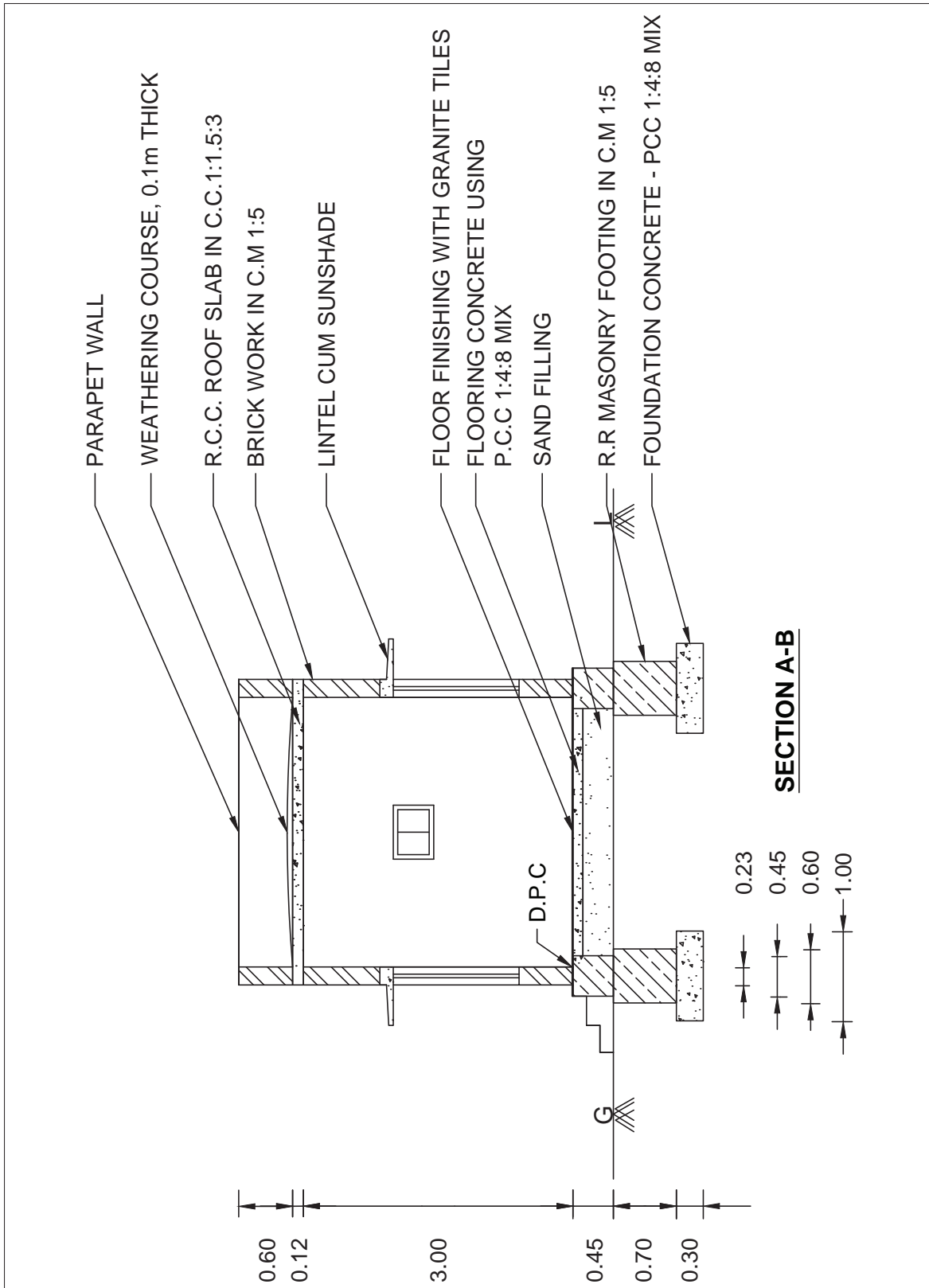

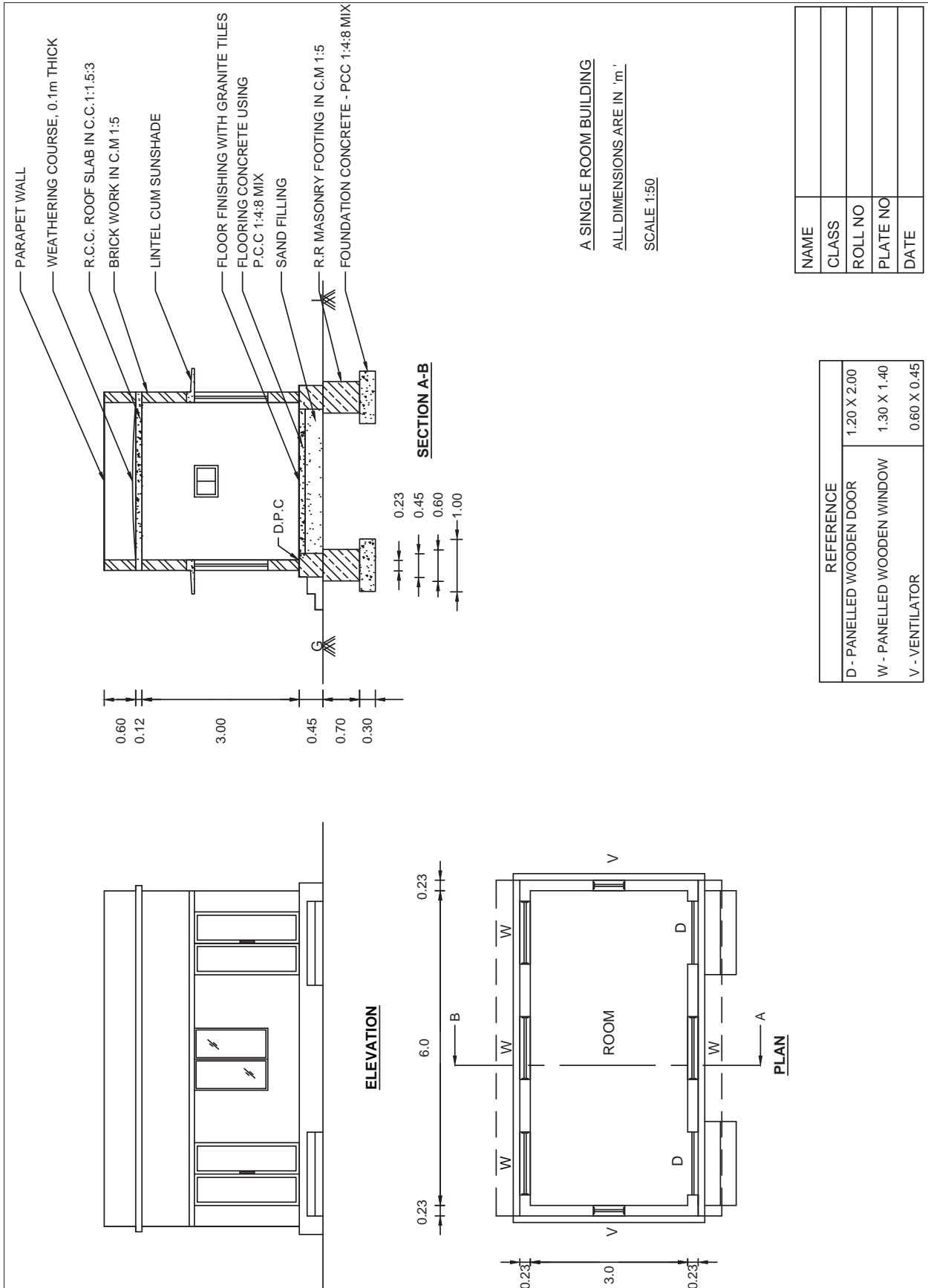

| | |
|----------|--|
| NAME | |
| CLASS | |
| ROLL NO | |
| PLATE NO | |
| DATE | |

| | |
|-----------------------------|-------------|
| REFERENCE | |
| D - PANELLLED WOODEN DOOR | 1.20 X 2.00 |
| W - PANELLLED WOODEN WINDOW | 1.30 X 1.40 |
| V - VENTILATOR | 0.60 X 0.45 |

5) A RESIDENTIAL BUILDING – Using AUTO CAD

The following line sketch shows the internal dimensions of A RESIDENTIAL BUILDING. Draw to a scale of 1:50 / 1:00 the following views: using AUTO CAD

- A) Plan
- B) Section on AB
- C) Elevation

| SPECIFICATIONS | |
|-------------------|--|
| a) FOUNDATION | Depth of foundation is 1.2 m below natural ground level. The concrete base course is 1.2 m wide and 0.3 m thick in PCC of 1:4:8 mix |
| b) FOOTING | Isolated footings as per design in RCC 1:1.5:3 will be provided in appropriate places. The breadth and thickness of footing will be 0.90 m and 0.45 m respectively. Over the footing, RCC column 0.23 x 0.23m size are raised up to the grade beam level. |
| c) GRADE BEAM | A beam of size 0.23 x 0.30 m is provided as per the structural design around the building up to the ground level. |
| d) BASEMENT | The basement will be of brick masonry in CM 1:5 and of height 0.6m above the Grade beam. The thickness of plinth wall is 0.23m and a damp proof course 0.02m thick in CM 1:3 which is mixed with 5% crude oil will be provide around the building. |
| e) FLOORING | Over 0.450m depth of sand filling, flooring of 0.15m thick in CC 1:4:8 mix finished with marble stone is provided. |
| f) SUPERSTRUCTURE | RCC columns 0.23 x 0.23m are raised above the Grade beam upto roof level in correct sequence. The thickness of walls above plinth level is 0.23 in brick work using CM 1:5. The height of the parapet wall is 0.9 m above the roof top level. Lintel – cum – sunshade will be provided over the door and window openings. Thickness and bearing of RCC lintel in CC 1:1.5:3 will be 0.15m. The projection of sunshade will be 0.45m from the wall. The thickness is 0.08m at support and 0.05m at free end. Ceiling height will be 3m above the floor level. |
| g) ROOFING | Roofing will be of flat RCC in CC 1:1.5:3, 0.12m thick. A weathering course of 0.1m thick is provided over the roof slab with sufficient slope to drain rainwater. |
| h) STEPS | Tread = 0.3m. Rise = 0.15m. |

REFERENCE

| | | |
|-----|------------------------|------------------|
| D - | Panelled Wooden Door | - 1.2 m x 2.10 m |
| D1 | Panelled Wooden Door | - 0.90 m x 2.10m |
| D2 | PVC door | - 0.75 x 2.10 m |
| W - | Panelled Wooden Window | - 1.2 m x 1.40 m |
| V - | Glazed Ventilator | - 0.6 mx0.45m |

Assume any other data suitably, if necessary.

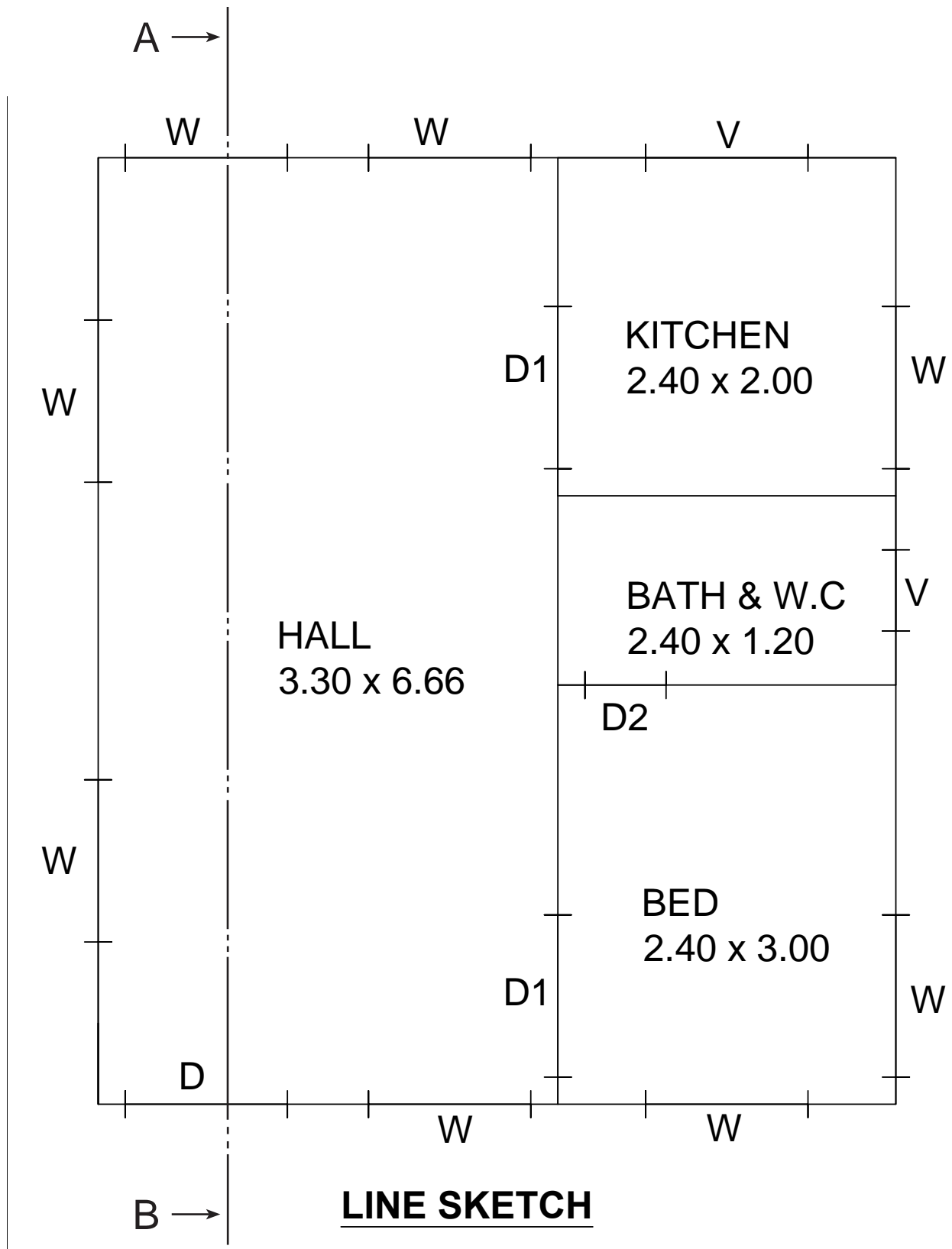

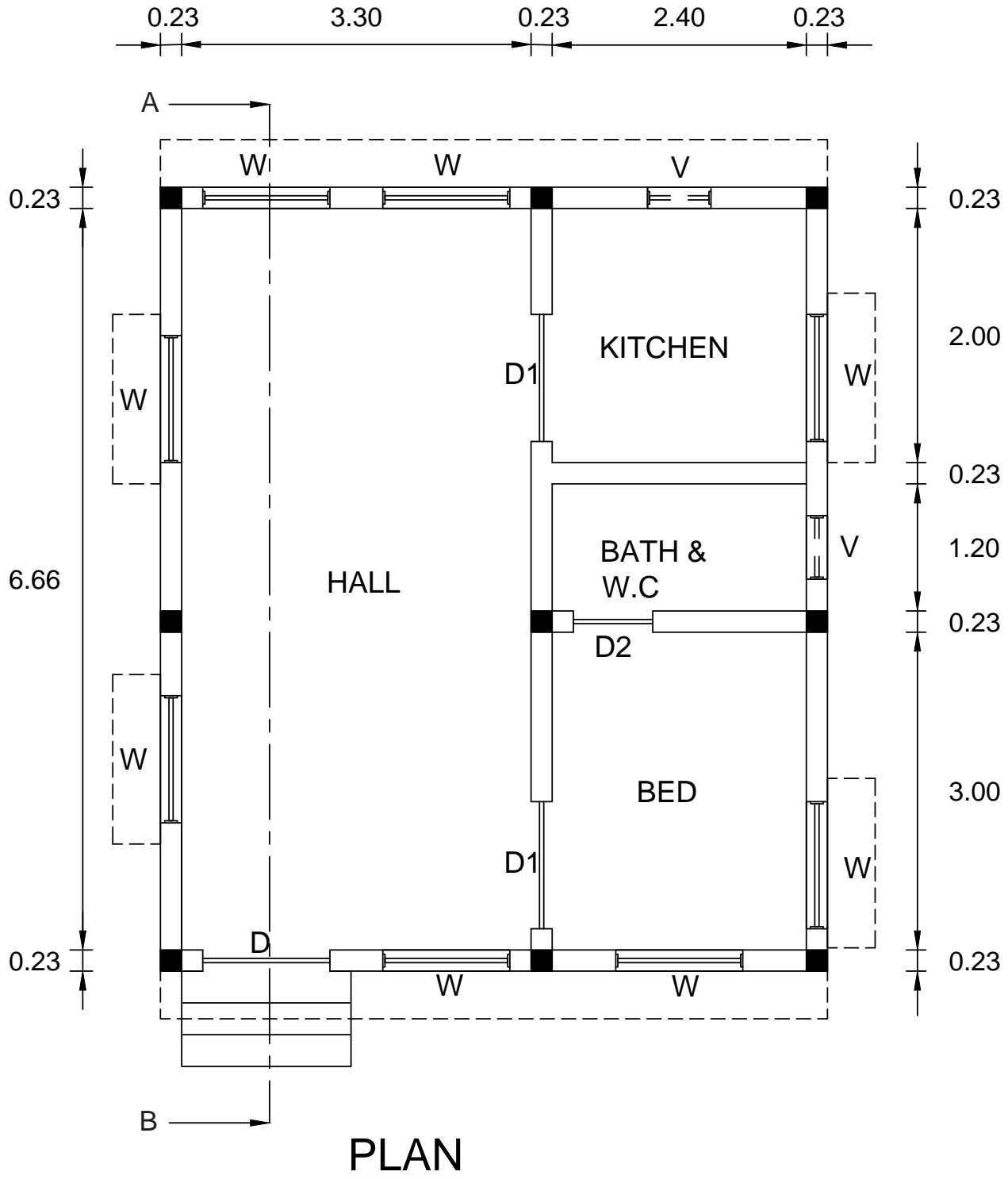

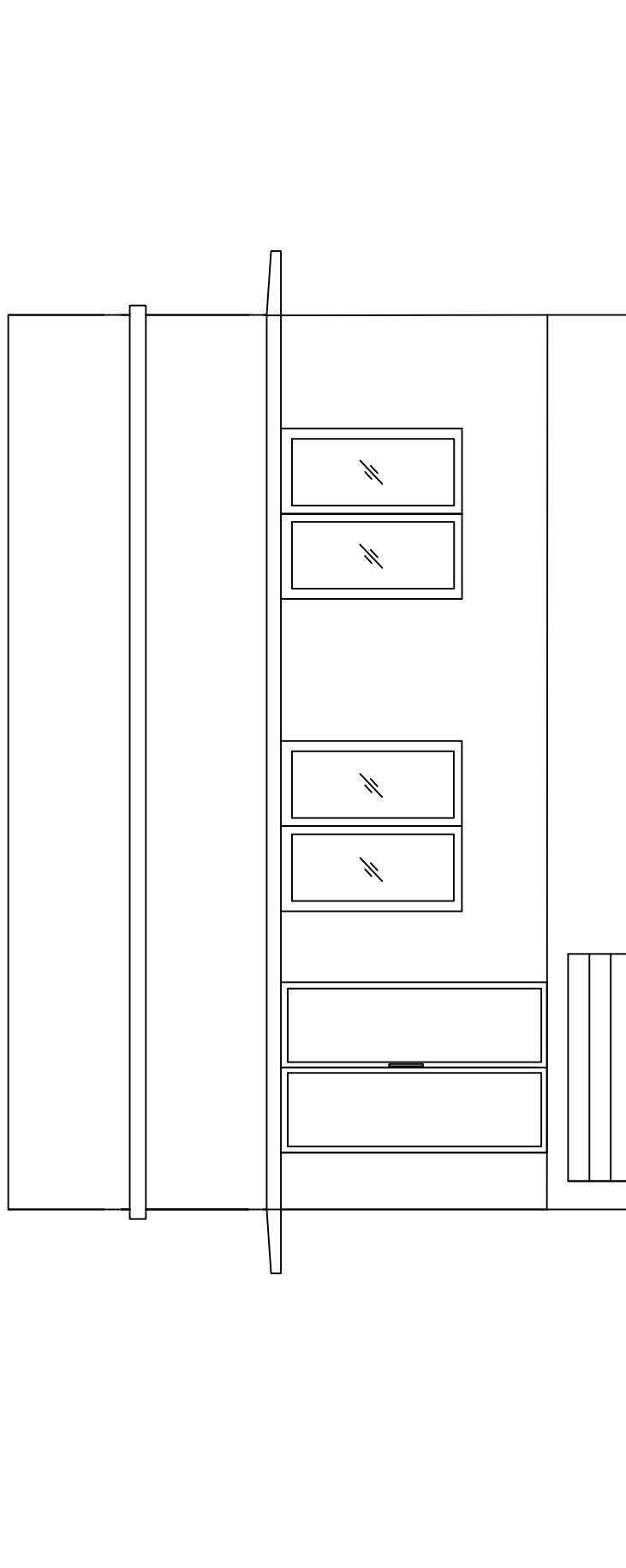

ELEVATION



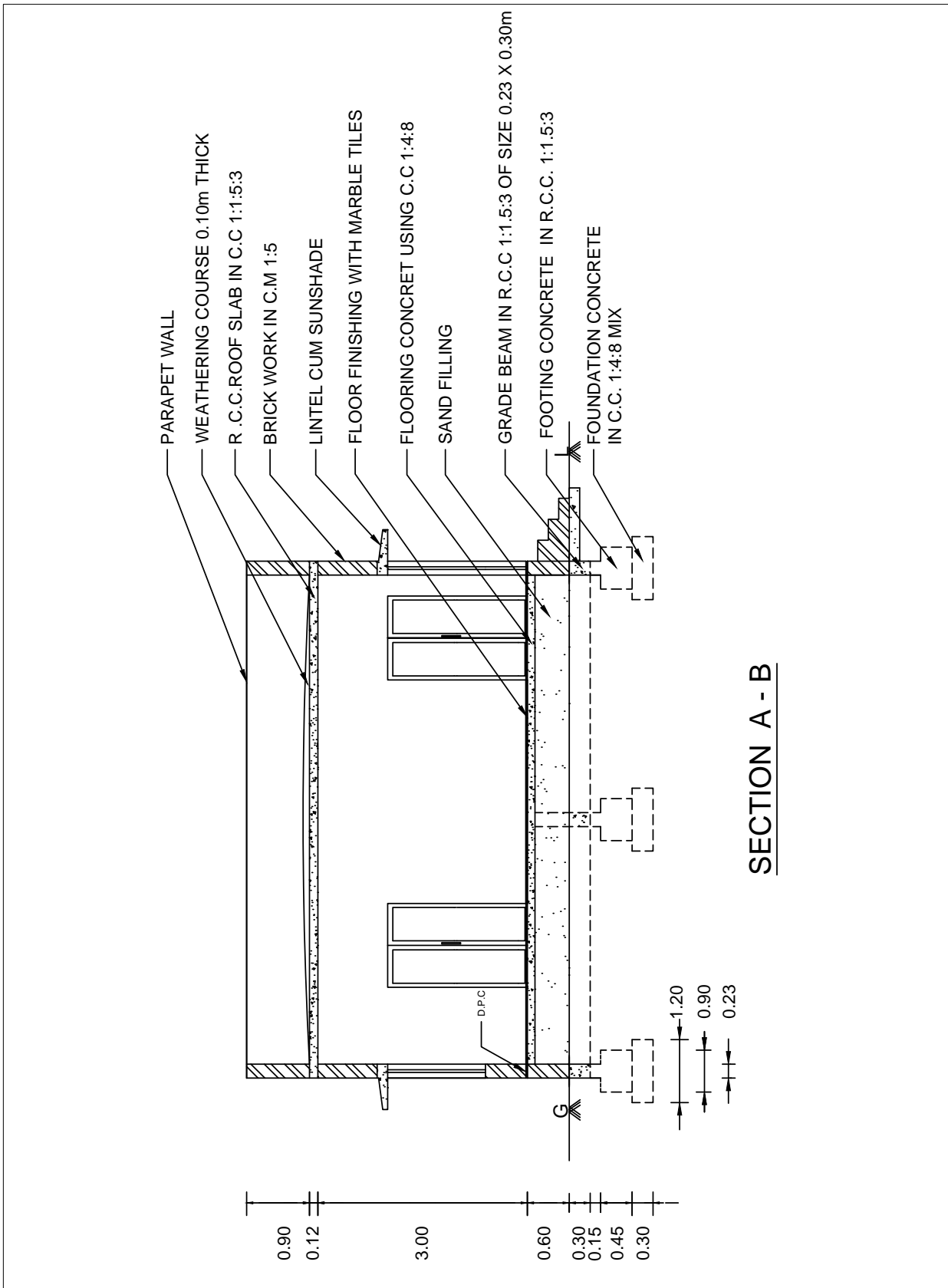

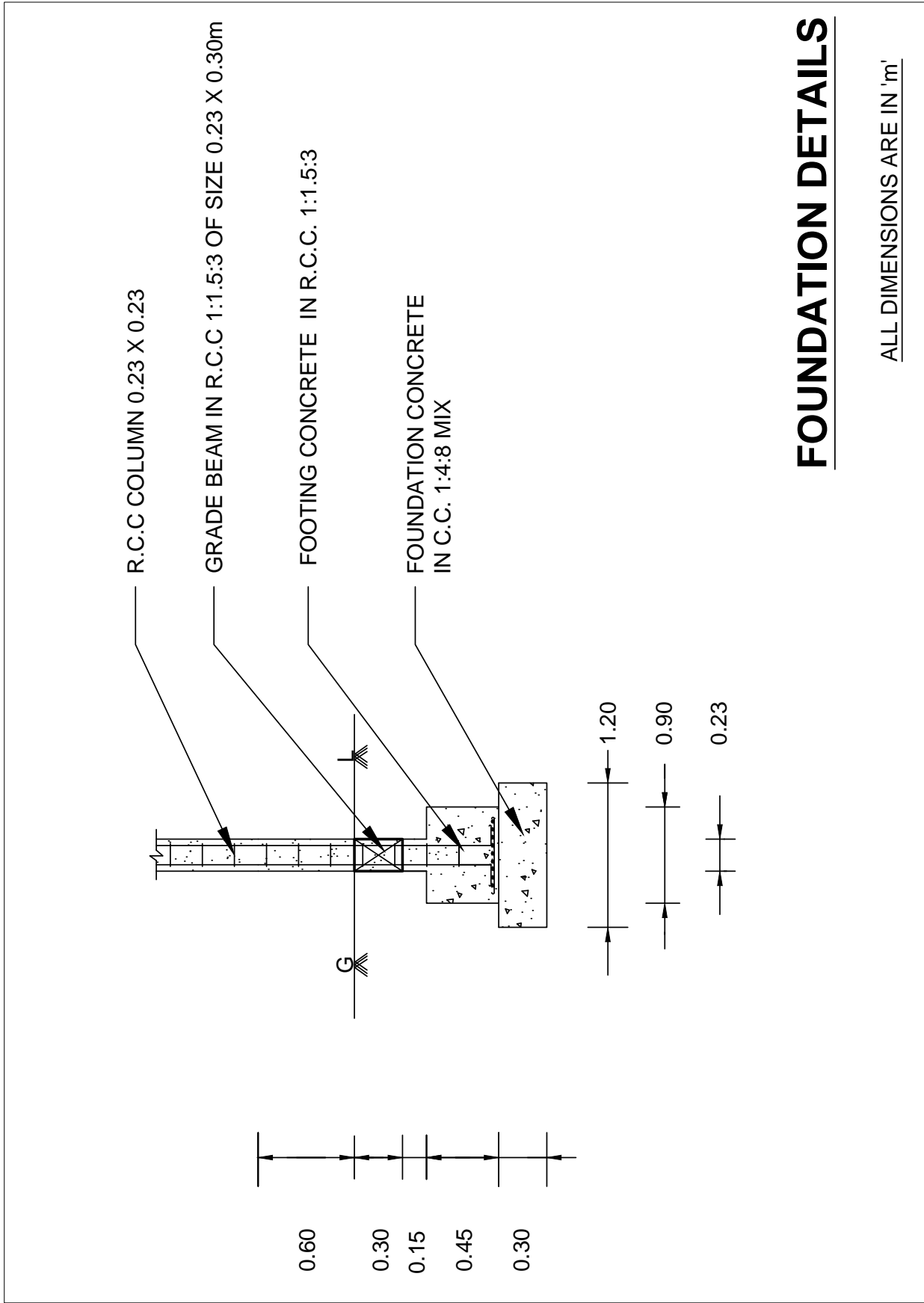

FOUNDATION DETAILS

ALL DIMENSIONS ARE IN 'm'

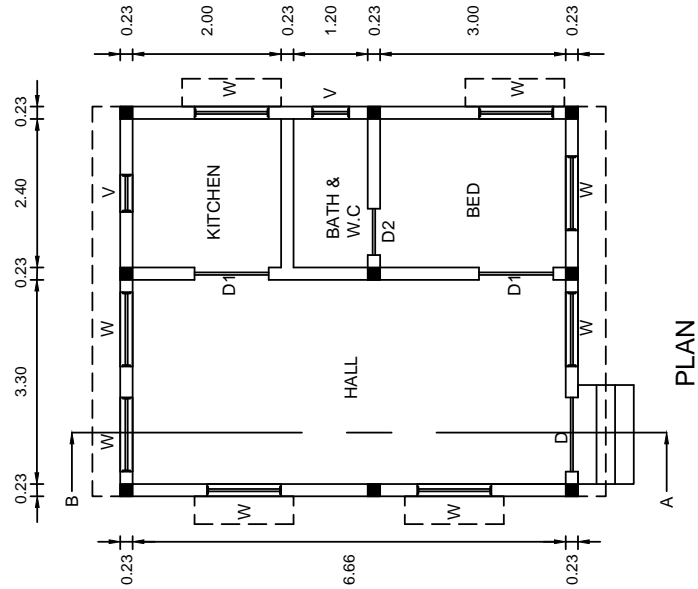
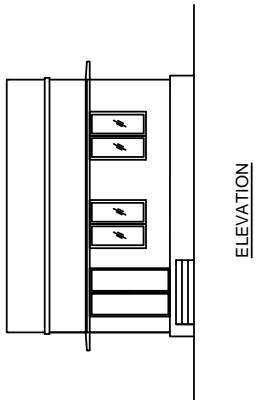
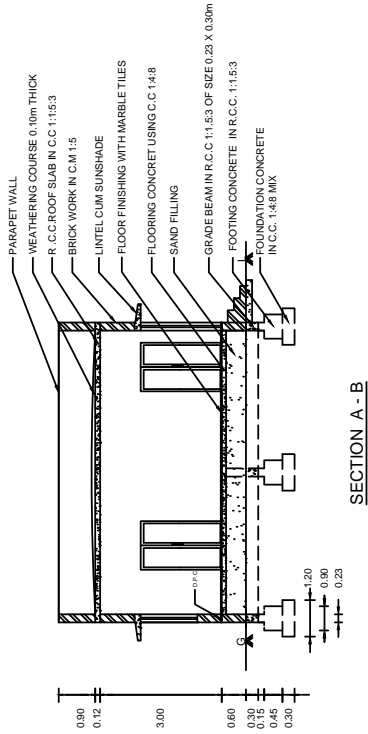

A RESIDENTIAL BUILDING

ALL DIMENSIONS ARE IN 'm'

SCALE 1:100

| REFERENCE | DESCRIPTION | SIZE |
|-----------|------------------------|-------------|
| D1 | PANELLED WOODEN DOOR | 1200 X 2100 |
| D2 | PVC DOOR | 675 X 2100 |
| D1 | PANELLED WOODEN DOOR | 680 X 2100 |
| W | PANELLED WOODEN WINDOW | 1200 X 1140 |
| V | VENTILATOR | 600 X 300 |

| NAME | CLASS | ROLL NO | PLATE NO | DATE |
|------|-------|---------|----------|------|
| | | | | |

6) A SCHOOL BUILDING – Using AUTO CAD

The following line sketch shows the internal dimensions of A SCHOOL BUILDING. Draw to a scale of 1:50/1:100, the following views: using AUTO CAD

- A) Plan
- B) Section on AB
- C) Elevation

| SPECIFICATIONS | |
|-------------------|---|
| a) FOUNDATION | Depth of foundation is 1.50 m below natural ground level. The concrete base course is 1.2 m wide and 0.3 m thick in PCC of 1:4:8 mix |
| b) FOOTING | Isolated footings as per design in RCC 1:1.5:3 will be provided in appropriate places. The breadth and thickness of footing will be 1.00 m and 0.45 m respectively. Over the footing, RCC column 0.23 x 0.23m (or) 0.23 x 0.45 m size are raised upto the grade beam level . |
| c) GRADE BEAM | A beam of size 0.23 x 0.45 m is provided as per the structural design around the building up to the ground level. |
| d) BASEMENT | The basement will be of brick masonry in CM 1:5 and of height 0.45m above the Grade beam. The thickness of plinth wall is 0.23m and a damp proof course 0.02m thick in CM 1:3 which is mixed with 5% crude oil will be provide around the building. |
| e) FLOORING | Over 0.30m depth of sand filling, flooring of 0.15m thick in CC 1:4:8 finished with tiles is provided. |
| f) SUPERSTRUCTURE | RCC columns 0.23 x 0.23 m and 0.23 x 0.45 m are raised in right places above the Grade beam upto roof level in correct sequence. The thickness of walls is 0.23 in brick work using CM 1:5. The height of the parapet wall is 0.6 m above the roof top level. Lintel – cum – sunshade will be provided over the door and window openings. Thickness and bearing of RCC lintel in CC 1:1:5:3 will be 0.15m. The projection of sunshade will be 0.45m from the wall. The thickness is 0.08m at support and 0.05m at free end. Ceiling height will be 3m above the floor level. |
| g) ROOFING | Roofing will be of flat RCC in CC 1:1.5:3, 0.12m thick. A weathering course of 0.1m thick is provided over the roof slab with sufficient slope to drain rainwater. |
| h) STEPS | Tread = 0.3m. Rise = 0.15m. |

REFERENCE

- D - Panelled Wooden Door - 1.2 m x 2.10 m
- W - Panelled Wooden Window - 1.2 m x 1.40 m

Assume any other data suitably, if necessary.

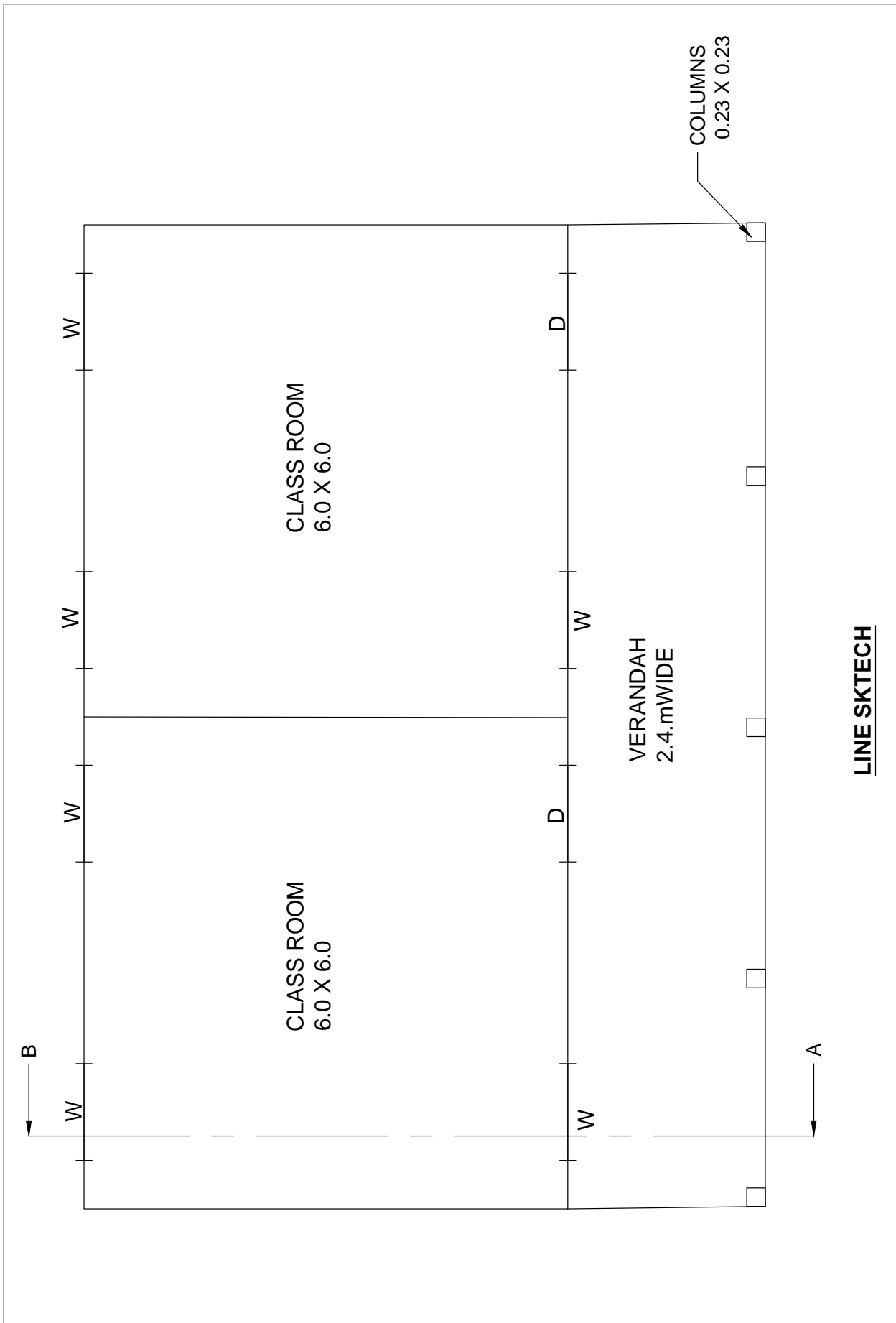

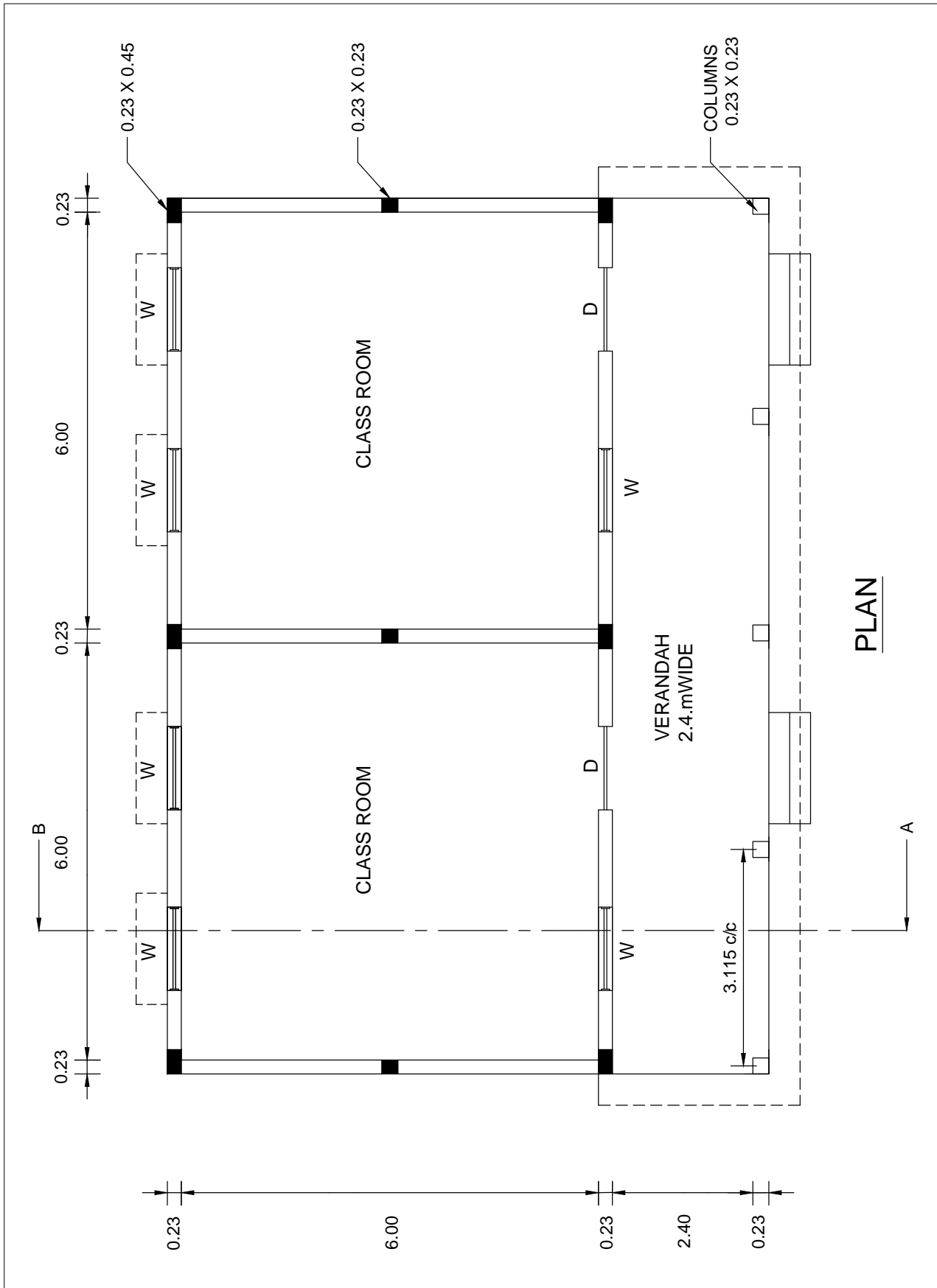

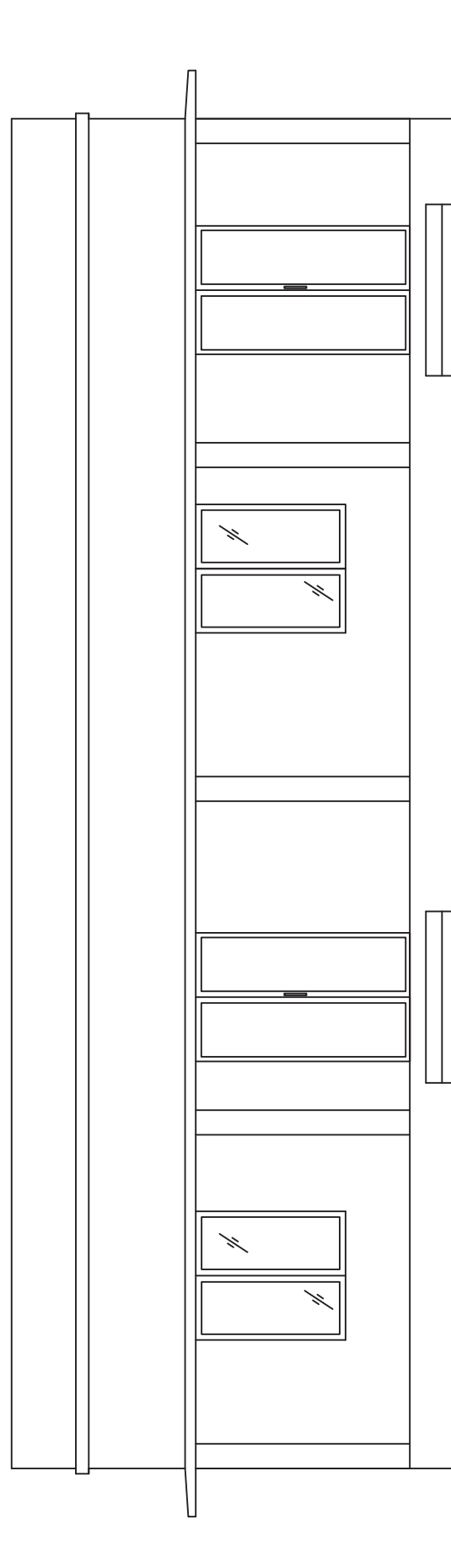

ELEVATION



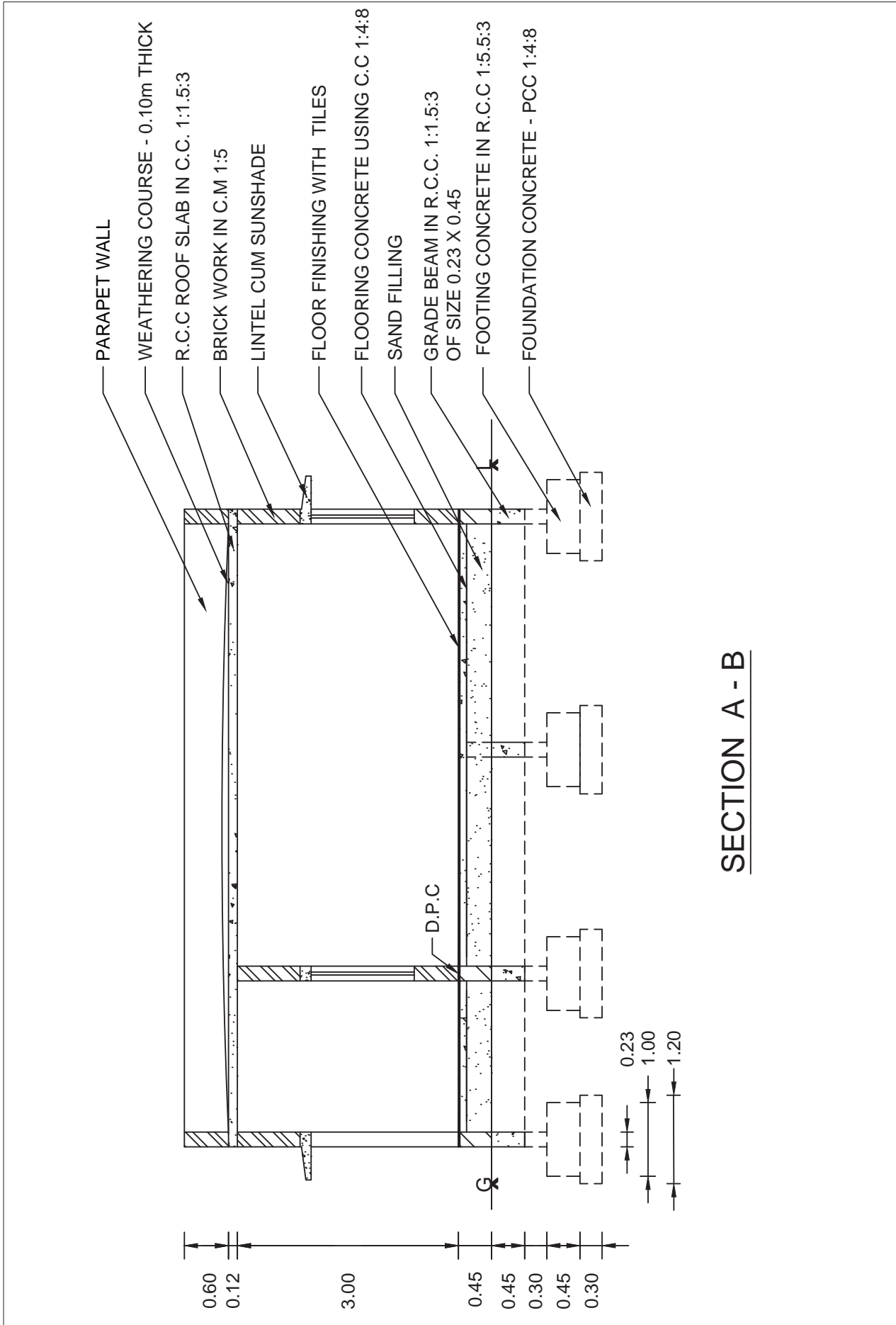

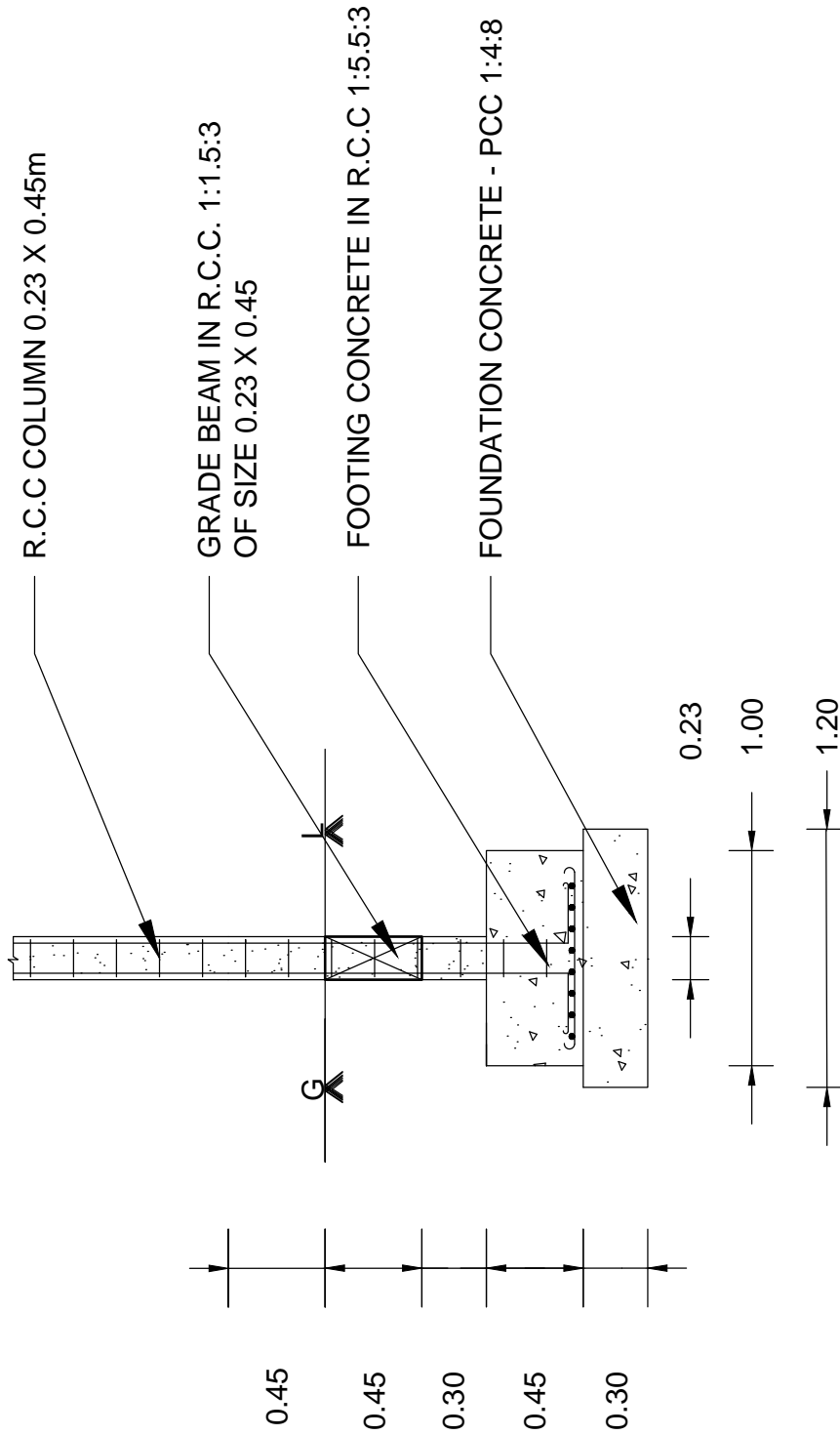

FOUNDATION DETAILS

ALL DIMENSION ARE IN 'm'

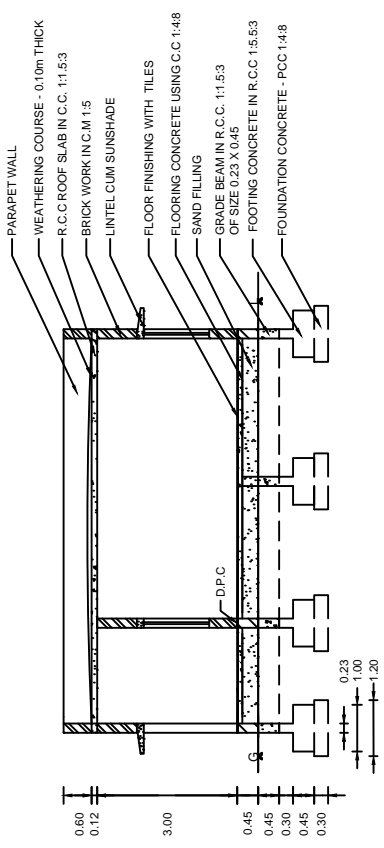

SECTION A - B

A SCHOOL BUILDING

ALL DIMENSION ARE IN 'm'

SCALE 1:100

| | |
|----------|--|
| NAME | |
| CLASS | |
| ROLL NO | |
| PLATE NO | |
| DATE | |

| REFERENCE | |
|------------------------|-------------|
| PANELLED WOODEN DOOR | 1.20 X 2.00 |
| PANELLED WOODEN WINDOW | 1.20 X 1.40 |

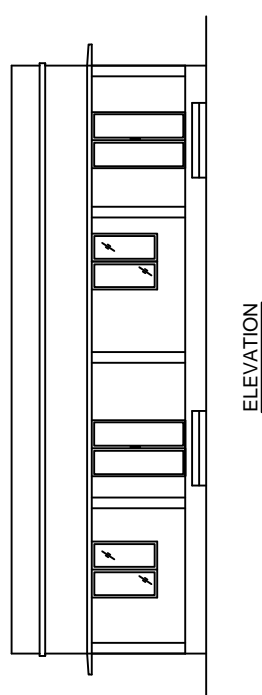

ELEVATION

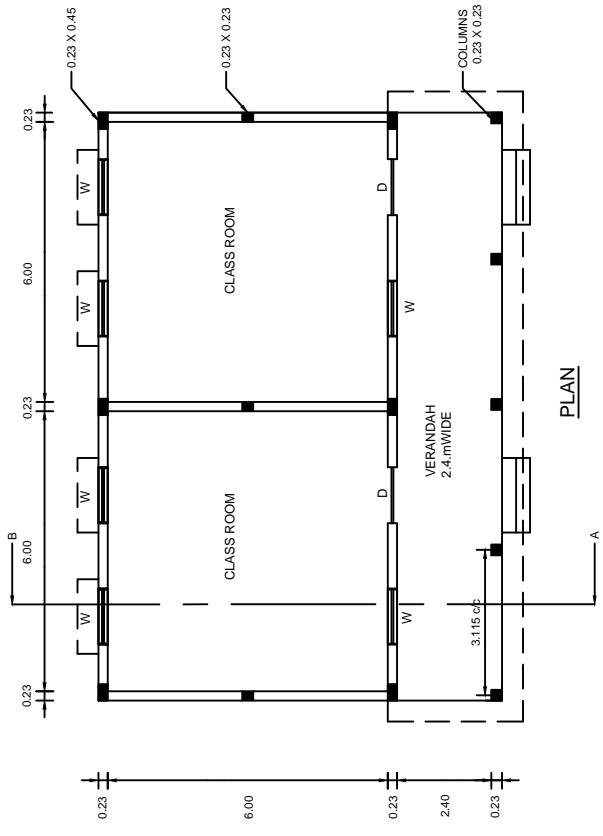

PLAN

III. QUANTITY SURVEYING – DETAILED AND ABSTRACT ESTIMATE

7) Prepare the Detailed and Abstract Estimate for a Compound Wall for the following items of work.

1. Earth work excavation for foundation
2. Foundation concrete in P.C.C 1:4:8
3. R.C.C Footing in 1:1.5:3 mix
4. R.C.C columns in 1:1.5:3 mix
 - a. Up to Grade beam
 - b. above Grade beam
5. R.C.C Grade beam 0.23×0.30 m size in 1:1.5:3 mix
6. Brick work above the Grade beam in C.M 1:5 mix
7. Plastering the Brick work (Both sides)
8. White washing for the plastered wall (Both sides)
9. Providing and fixing of Gate.
10. Painting with enamel paint for the gate.

Detailed Estimate:

| Sl. No. | Description of Item | Nos. | Dimensions in Metre | | | Quantity | Total |
|---------|---------------------|------|---------------------|---------|--------------|----------|-------|
| | | | Length | Breadth | Depth/Height | | |
| | | | | | | | |

Abstract Estimate:

| Sl. No. | Description of Item | Quantity | Rate/Unit | Amount |
|---------|---------------------|----------|-----------|--------|
| | | | | |

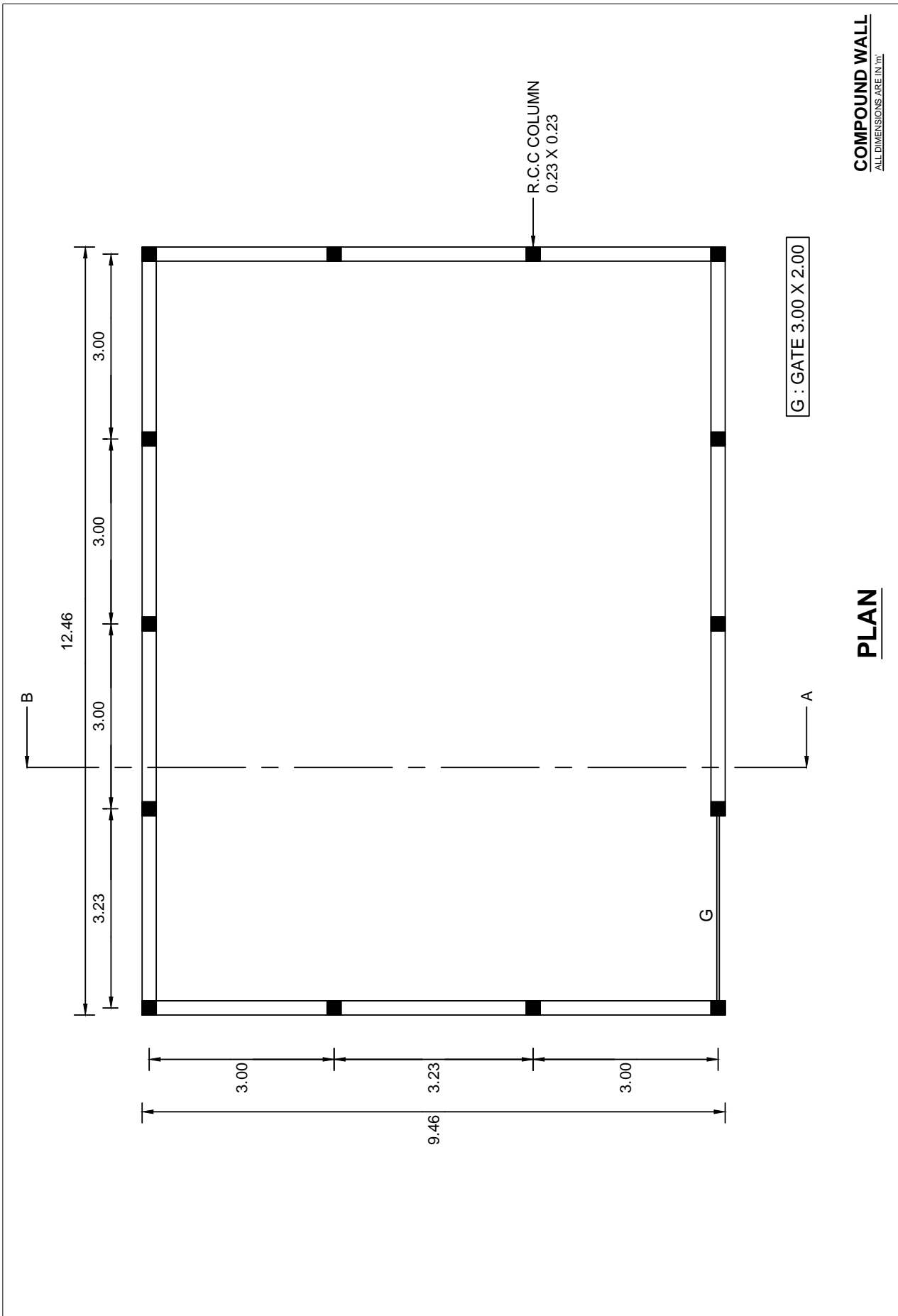

COMPOUND WALL
ALL DIMENSIONS ARE IN 'M'

PLAN



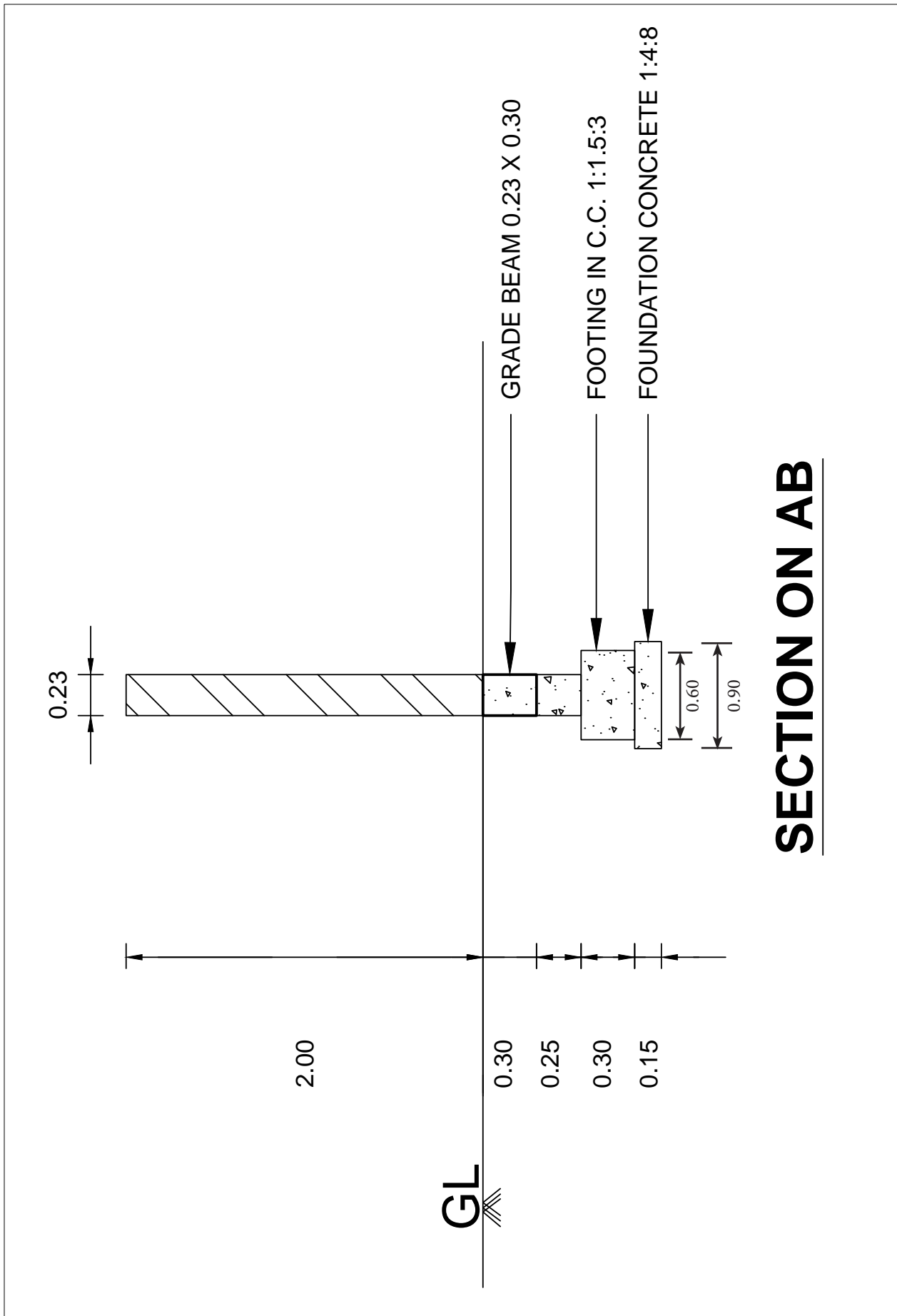

8) Prepare the Detailed and Abstract Estimate for a single room building for the following items of work.

1. Earthwork excavation for foundation
2. Foundation concrete in P.C.C 1:4:8
3. R.R. masonry in C.M 1:5
 - a) Footing
 - b) Basement
4. Damp proof course 0.02 m thick
5. Sand filling in basement.
6. Flooring concrete in P.C.C 1:4:8
7. B.W in super structure (including parapet) in C.M 1:5
8. Lintel cum sunshade in RCC 1:1.5:3
9. RCC roof in 1:1.5:3 mix – 0.12 m thick.
10. Providing door and windows (including safety grill)
11. Ceiling plastering in C.M 1:4.
12. Plastering the Brick work (Both side)
13. Steps.
14. White washing the plastered surface (both sides)
15. Weathering course in B.J.L.C - 0.1 m thick.
16. Color washing the white washed surface with emulsion paint.
17. Floor finishing using granite tiles.
18. Painting the doors and windows with enamel paint.

Detailed Estimate:

| Sl. No. | Description of Item | Nos. | Dimensions in Metre | | | Quantity | Total |
|---------|---------------------|------|---------------------|---------|--------------|----------|-------|
| | | | Length | Breadth | Depth/Height | | |
| | | | | | | | |

Abstract Estimate:

| Sl. No. | Description of Item | Quantity | Rate/Unit | Amount |
|---------|---------------------|----------|-----------|--------|
| | | | | |

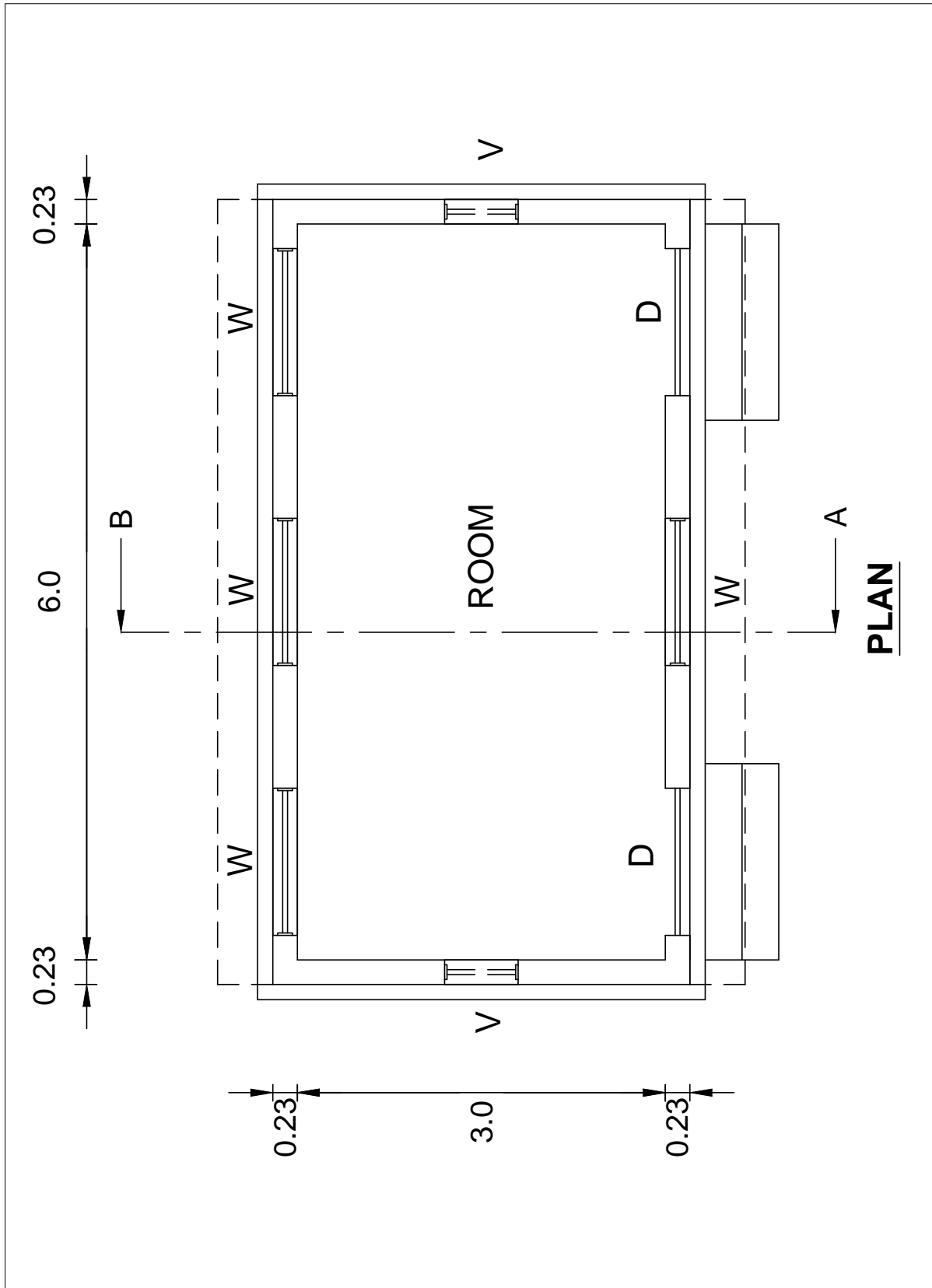

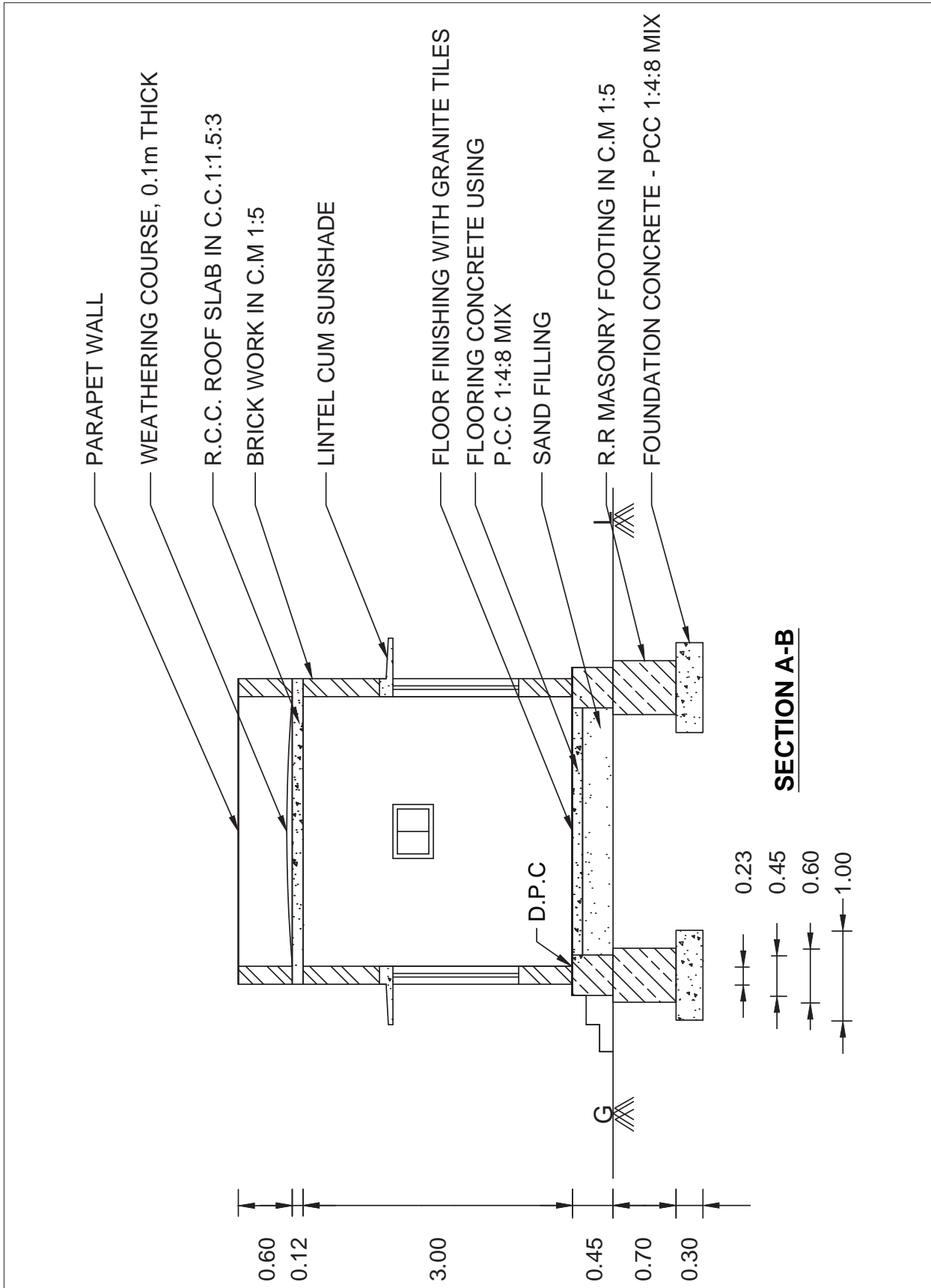

IV. SURVEYING

9) Fly leveling – Closed Traverse

Conduct fly levelling for a closed traverse using a dumpy level (10 ground points with 2 change points). Enter the readings taken in a level book form and reduce the levels using height of collimation method / Rise and fall method. Do the arithmetic check.

Height of Collimation Method

| Station | B.S | I.S | F.S | HOC | R.L | Remarks |
|---------|-----|-----|-----|-----|-----|---------|
| | | | | | | |
| | | | | | | |
| | | | | | | |
| | | | | | | |
| | | | | | | |
| | | | | | | |
| | | | | | | |
| | | | | | | |
| | | | | | | |
| | | | | | | |

Rise and Fall Method

| Station | B.S | I.S | F.S | Rise | Fall | R.L | Remarks |
|---------|-----|-----|-----|------|------|-----|---------|
| | | | | | | | |
| | | | | | | | |
| | | | | | | | |
| | | | | | | | |
| | | | | | | | |
| | | | | | | | |
| | | | | | | | |
| | | | | | | | |
| | | | | | | | |
| | | | | | | | |

10) Fly leveling – Open Traverse

Conduct fly leveling for an open traverse using a dumpy level (10 ground points with 2 change points). Enter the readings taken in a level book form and reduce the levels using height collimation method / Rise and fall method. Do the arithmetic check.

Height of Collimation Method

| Station | B.S | I.S | F.S | HOC | R.L | Remarks |
|---------|-----|-----|-----|-----|-----|---------|
| | | | | | | |
| | | | | | | |
| | | | | | | |
| | | | | | | |
| | | | | | | |
| | | | | | | |
| | | | | | | |
| | | | | | | |
| | | | | | | |
| | | | | | | |
| | | | | | | |

Rise and Fall Method

| Station | B.S | I.S | F.S | Rise | Fall | R.L | Remarks |
|---------|-----|-----|-----|------|------|-----|---------|
| | | | | | | | |
| | | | | | | | |
| | | | | | | | |
| | | | | | | | |
| | | | | | | | |
| | | | | | | | |
| | | | | | | | |
| | | | | | | | |
| | | | | | | | |
| | | | | | | | |
| | | | | | | | |



Case Study

Jagatheswari

I am happy and delighted to be the student of most famous Government Girls Higher Secondary School at Salem. Students learning there and enriched their talent.

I (Mrs M.Jagatheswari), completed my SSLC during 1991, then continued 11th standard Building Maintenance group during the period of 1991 – 1993. Being the topper of this group, I thank my Head Mistress, teachers and my parents for their support.

Teacher has to be, **T** – Talented, **E** – Encouraging, **A** – Affectionate **C** – Caring, **H**– Humane, **E** – Energetic, **R** – Regulate. For me I found the above said qualities in all my teachers.

After completing Diploma in Civil (DCE), in the year 1995, I worked as a designer in an architect office for two years then as draughtsman temporary in TNEB for 5 years. In 2002 I started my own concern named as ‘Mani Engineering Associates’ where I had TNEB contracts throughout TamilNadu and also did 1.5 crores worth private building constructions.

After completing my UG in B.Tech Civil in the year 2007, I worked as Lecturer in Salem Polytechnic for two years. After my PG in M.E. (Structural Engineering) in the year 2011, I joined as Associate Professor / HoD Civil Engineering in AVS College of Technology. Now I am pursuing Ph.D.

I thank the almighty, my parents and teachers who have supported, throughout my career to achieve all these.

Jagatheswari

**Case Study****Krishna Suthan Aiyappazham**

My name is Krishna Suthan Aiyappazham.

I studied at the Government Higher Secondary School, Agastheeswaram, Kanniyakumari district. After completing SSLC, I joined Draughtsman Civil Group in higher secondary during the year 2003. I learnt a lot there because of my inspiring teachers. I studied Diploma in Civil Engineering and also graduated in the same branch. The basics I studied in Draughtsman civil helped me the most in my higher studies.

After graduation I joined in a private company located at Bangalore. Later I shifted to another private company in Chennai. Then I got a chance to work in countries like Singapore and Algeria. Presently, I am working as a civil engineer with good salary in an Indian company in Dubai. I am grateful to my teachers and my family members who helped me to be in this position.

Even though I am educated in Tamil medium, the language has never been a barrier for my upliftment in my life. If you are ready to work hard, you will taste the success one day.

My sincere congratulations to all of you.

Regards

—Krishna Suthan Aiyappazham



Premnivas

Success is not an accident it is hard work, preserverance, learning, sacrifice and most of all, love of what you are doing. -Pele.

I (Premnivas) studied in Venkata Subba Reddiar Government Technical Higher Secondary School, Puducherry after SSLC. When I opted Building maintenance group, all my relatives and friends were not happy thinking that there is limited scope for that course. With the skillful teaching and wonderful guidance of my teacher, I completed my higher secondary level successfully.

I believe in myself and with great effort got admission in Pondicherry University for B.Tech., and completed that course with flying colours.

I started my career as a Project Engineer and worked few years in Puducherry for the company named 'The Resident group'. I gained a lot of experience and got exposure working abroad in countries like Bahrain, Singapore, etc.

Currently I am working as a project Manager on various projects across Southeast Asia and now settled in Singapore.

'Education is not the learning of facts, but the training of the mind to think' as Albert Einstein said.

Time management is the important tool towards achieving your goals.

Our time is limited, don't waste it. Don't be trapped by dogma. Don't let the noise of other's opinion drowned your inner voice. Believe in yourself and the rest will fall into place.

Thank you.

Premnivas.



Marks Allocation

Basic Civil Engineering - Theory - 2nd Year

| | |
|---|--------------------------|
| Part I Choose the correct answer | $15 \times 1 = 15$ marks |
| Part II Answer any ten questions | $10 \times 3 = 30$ marks |
| Part III Answer any five questions in brief | $5 \times 5 = 25$ marks |
| Part IV Answer all the questions in details | $2 \times 10 = 20$ marks |

| | |
|----------------------------|------------------|
| Total | 90 marks |
| Internal Assessment | 10 marks |
| Total | 100 marks |



Model Question Paper - 1

Time-2.30 hrs

Max.Marks: 90

Part - I

Choose the correct answer

(15 x 1 = 15)

1. For better visualization, a house should be constructed on _____ plot.
a. elevated b. low lying c. rectangle d. square
2. The best suited size of a bed room is _____
a. 4.00 x 3.00 m b. 4.60 x 3.50 m c. 3.60 x 4.60 m d. 4.50 x 3.60 m
3. Aluminium powder is used at a rate of _____ by volume in Autoclaved aerated concrete.
a. 0.06 – 0.08 % b. 0.07 – 0.08 % c. 0.05 – 0.08 % d. 0.04 – 0.08 %
4. Abbreviation of TMT bar is _____
a. Thermo Mechanically Tested b. Thermo Mechanically Treated
c. Thermo Manually Tested d. Techno Mechanically Treated
5. Geodetic surveying is also called _____ survey.
a. Aerial b. Astronomical c. Trigonometrical d. Plane
6. A level which represents the average sea water level is _____
a. Mean sea level b. Clean sea level c. Mid sea level d. Top sea level
7. _____ impurities gives taste, odour, turbidity and colour to water.
a. Chemical b. Physical c. Bacteriological d. Biological
8. Removal of _____ from water is known as Water softening.
e. Odour f. Turbidity g. Softness h. Hardness
9. The normal flow of sewage during the rainy season of the year is called _____.
a. Normal weather flow b. Dry weather flow
c. Wet weather flow d. Wet and Dry weather flow

10. The overall length of Golden Quadrilateral is _____ km.
a. 5646 b. 6465 c. 4656 d. 6456
11. The rate of rise or fall of the road along its alignment is called _____.
a. Sight distance b. Super elevation c. Road gradient d. Camber
12. _____ is a pressure that a fluid exerts when it is at rest.
a. Static pressure b. Atmospheric pressure
c. Gauge pressure d. Absolute pressure
13. The loss of head due to friction is called _____.
a. Secondary loss b. Pressure loss c. Minor loss d. Major loss
14. _____ is commonly used today to describe an earthquake's magnitude
a. Metric scale b. Bio metric scale
c. Richter scale d. Non-metric scale
15. _____ are more destructive and harmful to the society than any other weapon.
a. Machine gun b. Antiaircraft gun
c. Combat weapons d. Nuclear weapons

Part – II

**Answer any ten questions in one or two sentences
(Question number 28 is compulsory)**

(10 x 3 = 30)

16. List the types of residential houses.
17. Define - UPVC.
18. Write any four uses of glass in buildings.
19. List the types of survey based on the nature of field of surveying.
20. Write the purpose of chain surveying.
21. Write short note on screening in water treatment units.
22. Define Water carriage system in system of sanitation.
23. Write shortly about North – South and East – West corridor road project.
24. Define – Sight distance.
25. Write the Darcy's formula to find out head loss in terms of velocity and discharge..
26. Define – priming of pump.
27. List some of the natural disasters.
28. Write the causes of flood.

Part – III

Answer any five questions briefly
(Question number 35 is compulsory)

(5 x 5 = 25)

29. Write the uses of Ferro cement.
30. Write briefly the procedure of levelling up a dumpy level.
31. Write the objectives of water treatment.
32. Write briefly about soak pit used to dispose effluents from a septic tank.
33. Write briefly about Road curves.
34. Draw a diagram of centrifugal pump and mention its parts.
35. Write the precautions to be taken before and after a cyclone.

Part – IV

Answer both questions in detail

(2 x 10 = 20)

36. Write in detail about the benefits of constructing a verandah in a house.

(or)

The readings taken in a traverse using a dumpy level instrument are as follows:

1.315, 1.905, 2.500, 2.760, 0.755, 0.690, 1.330, 1.650, 1.695, 2.000, 2.765, 3.100 and 3.330. The instrument was shifted after 3rd and, 8th and 10th readings. The R.L of Ist point is +300.00m. Enter the readings in a level book form and reduce the R.L of other points by any one method. Do the arithmetic check.

37. Write the construction procedure of a bituminous road in detail with sketch.

(or)

Determine the loss of head in a pipe line 200 mm diameter and 450m long. The discharge of Water through the pipe is 0.255 m³/sec. Take the value of friction factor as 0.002.



Model Question Paper - 2

Time-2.30 hrs

Max.Marks: 90

Part-I

Choose the correct answer

(15 x 1 = 15)

1. During ancient times man used to live in _____.
a) apartments b) row houses c) dens d) skyscraper.
2. The room next to verandah is _____.
a) bath room b) pooja room c) kitchen d) living room
3. Light weight concrete reduces the _____ of the structure.
a) live load b) dead load c) wind load d) ice load
4. The spread of self compacting concrete ranges from _____ inches.
a) 1 to 32 b) 10 to 20 c) 20 to 40 d) 30 to 50.
5. The length of a link in a metric chain is _____.
a) 0.1m b) 0.2m c) 0.3m d) 0.5m.
6. French cross staffs are used for setting out _____.
a) acute angle b) obtuse angle c) straight angle d) right angle.
7. In India the quantity of water required for fire demand is _____ of total consumption.
a) 5 to 10% b) 10 to 20% c) 20 to 30% d) 30 to 35%.
8. The primary source of water is _____.
a) rivers b) sea c) rain d) lake .
9. The gradient of 1 metre diameter sewer is _____.
a) 1 in 100 b) 1 in 60 c) 1 in 120 d) 1 in 200.
10. The mode of transport preferred for small distance is _____.
a) railway b) road c) water d) air .

Part-III**Answer any five questions briefly****(5 x 5 = 25)****(Question number 35 is compulsory)**

29. What are the properties of glass?
30. List the uses of GPS?
31. What are the impurities of water? Explain in brief.
32. List the important sewer appurtenances?
33. What is super elevation? How it is calculated?
34. Explain "vena contracta" with neat sketch.
35. Write short notes on "Cyclone".

Part-IV**Answer both questions in detail****(2 x 10 = 20)**

36. What are the rooms in a residence? Explain any four.

or

The following staff readings were observed successively with a level.

0.875, 1.235, 2.310, 1.385, 2.930, 3.125, 4.125, 0.120, 1.875 and 2.030. The first reading taken on B.M. of elevation 132.135m. The instrument has been moved after 2nd, 5th and 8th reading. Enter the readings in a field book form and reduce the R.Ls by any one method. Apply the usual checks.

37. What are the purposes of road arboriculture? How the trees are selected?

or

A 300mm diameter and 600m long pipe connects two reservoirs. The difference in water pressure in two reservoirs is 3m. Determine the velocity of flow in the pipe. The Chezy's constant is 60.



Reference

1. “Drafting House Plans: A Simplified Drafting System for Planning and Design”, by June Curran
2. “Building, Planning and Drawing”, Dr.N.Kumaraswamy, A.Kameswara Rao
3. “Building Materials” by P.C.Varghese
4. “Modern Construction Materials” by C. Ganapathy
5. “Surveying” by Punmia B C
6. “Surveying and Levelling “, by N.N.Basak
7. “Water Supply Engineering”, by Dr. B.C. Punmia
8. “ Elements of Environmental engineering”, by K.N.Duggal
9. “Water Supply And Sanitary Engineering”, by S.C.Rangwala
10. “Highway Engineering”, by S.K.Khanna , C.E.G.Justo& A. Veeraragavan
11. “Highway Engineering”, by S.C.Rangwala, revised by K.S.Rangwala&P.S.Rangwala
12. “A Textbook of Highway and Traffic Engineering” by Saxena S.C
13. “Hydraulics”, by T.K.Palaniappan andV.M.Marimuthu
14. “A Textbook of Hydraulics Fluid Mechanics and Hydraulic Machines”, by R.S. Khurmi
14. “Environment Engineering and Disaster Management”, by Dr. Sanjay K.Sharma
15. “Disaster management”, by Palanivel K, Saravanavel J and Gunasekaran S



GLOSSARY

UNIT - I

| | | |
|----------------------|---|-------------------------------|
| Orientation | - | திசையமைவு |
| Shelter | - | தங்குமிடம் |
| Dens | - | குகைகள் |
| Sophistications | - | அதிநவீன வசதிகள் |
| Facilities | - | வசதிகள் |
| Anti social elements | - | சமூக விரோதிகள் |
| Privacy | - | தனிமை |
| Adequate | - | போதுமான |
| Heritage | - | பாரம்பரியம் |
| Governance | - | கட்டுப்பாடு |
| Depicts | - | சித்தரிப்பவை |
| Dwelling | - | இருப்பிடம் |
| Inmates | - | உள்ளிருப்பவர்கள் |
| Visualized | - | காட்சிபடுத்தும் |
| Stagnate | - | தேங்குதல் |
| Advisable | - | அறிவுறுத்தப்படுத்துவது |
| Rocky Strata | - | பாறை அடுக்குகள் |
| Deteriorated | - | சிதைந்த |
| Poultry farm | - | கோழி பண்ணை |
| Cremation ground | - | தகனம் செய்யுமிடம் |
| Garbage | - | குப்பை |
| Saturated | - | நிறைவுற்ற |
| Neighbour | - | அண்டை வீட்டார், அருகிலுள்ளோர் |
| Sea breeze | - | கடல் காற்று |

| | | |
|---------------|---|-----------------------------|
| Legal aspect | - | சட்ட அம்சம் |
| Encumbrance | - | வில்லங்கம் |
| Roominess | - | பரந்த நிலை |
| Creepers | - | கொடிகள் |
| Magnified | - | பெரிதாக, விரிவாக |
| Uninterrupted | - | தடையில்லா |
| Flexibility | - | நெகிழ்வு |
| Hygienic | - | சுகாதாரமான |
| Asset | - | சொத்து |
| Configuration | - | கட்டமைப்பு |
| Beneficial | - | நன்மையுடைய |
| Hospitality | - | விருந்தோம்பல் |
| Artistic | - | கலை |
| Thrifty | - | சிக்கனமான |
| Sky scraper | - | வானளாவிய கட்டடம் |
| Apartment | - | அடுக்குமாடி குடியிருப்புகள் |

UNIT-2

| | | |
|-------------|---|---|
| Composite | - | பலவகைப் பொருட்கள் கலக்கப்பட்ட |
| Foamed slag | - | நுரை கசடு |
| Haulage | - | வலிந்து இழுப்பதற்கு செலவாகும் ஆற்றல் |
| Aerated | - | காற்றூட்டப்பட்ட |
| Termite | - | கறையான் |
| Inhevent | - | இயற்கையாய் அமையப் பெற்ற |
| Compacting | - | கெட்டிப் படுத்துதல் |
| Impervious | - | உட்புக முடியாது |
| Brittle | - | எளிதில் நொறுங்கத்தக்க |
| Amorphous | - | குறிப்பிட்ட வடிவம் இல்லாதிருக்கிற |
| Hysteresis | - | காந்த ஆற்றலுக்கு காந்தத்தின் தூண்டுதல் இயக்கம் பிற்படும் நிலை |
| Perforated | - | துளையிடப்பட்ட |

| | | |
|---------------------------|---|---------------------------------|
| Offshore | - | கரையிலிருந்து விலகி |
| Corrosion | - | அரிப்பு |
| Scrap | - | கழிபொருள் |
| Admixtures | - | உப சேர்க்கை பொருட்கள் |
| Subtropical | - | வெப்ப மண்டல நிலையில் இருக்கின்ற |
| Sound Insulating Material | - | ஒலி காப்புப் பொருட்கள் |
| Isolation | - | தனிமைபடுத்தப்பட்ட நிலை |
| Dielectric | - | மின் காப்புப் பொருள் |

UNIT-3

| | | |
|--------------------|---|--|
| Chaining | - | சங்கிலி மூலம் நிலத்தை அளத்தல் |
| Ranging | - | இரு புள்ளிகளை நேர்கோட்டில் அமைத்தல் |
| Offsetting | - | இரு புள்ளிகளுக்கு இடைப்புள்ளி அமைத்தல் |
| Obstacles | - | தடைகள் |
| Level surface | - | சீர் மட்டப் பரப்பு |
| Horizontal Plane | - | கிடை தளம் |
| Vertical Plane | - | செங்குத்து தளம் |
| Mean sea level | - | சராசரி கடல் மட்டம் |
| Reduced level | - | குறைக்கப்பட்ட மட்டம் |
| Parallax | - | தோற்ற மாறுபாடு |
| Back sight | - | மீள் மட்ட அளக்கை |
| Intermediate sight | - | இடை நிலை அளக்கை |
| Fore sight | - | முன்னோக்கு அளக்கை |
| Bench mark | - | மட்டக்குறி |
| Change point | - | மாற்றுப் புள்ளி |

UNIT-4

| | | |
|------------|---|----------------------------------|
| Pathogens | - | கிருமிகள் |
| Sanitation | - | ஆரோக்கிய நிலை மேம்பாடு/துப்புரவு |
| Population | - | மக்கள் தொகை |

| | | |
|------------------|---|---|
| Water demand | - | நீர் தேவை |
| Intake | - | ஆற்றிலிருந்து குழாய்க்கோ, கால்வாய்க்கோ நீர் எடுத்துச் செல்லும் இடம் |
| Springs | - | நீருற்று |
| Infiltration | - | ஊடுருவல் |
| Whole some water | - | ஆரோக்கியமான தண்ணீர் |
| Distilled water | - | காய்ச்சி வடிகட்டிய தண்ணீர் |
| Turbidity | - | கலங்கல் |
| Residue | - | எச்சம், எஞ்சியது |
| Hardness | - | கடினத் தன்மை |
| Sedimentation | - | வண்டற் படிவம் |
| Coagulation | - | உறைதல் |
| Filtration | - | வடிகட்டுதல் |
| Chlorination | - | பாசிகச் செயற்பாடு / குளோரின் சேர்த்தல் |
| Coagulants | - | இறுகி உறையச் செய்யும் பொருள் |
| Screenings | - | சல்லடைக் கழிப்பு |
| Turbulence | - | கொந்தளிப்பு |
| Absorption | - | உறிஞ்சுதல் |
| Scraping | - | உரசித் தேய்த்தல் |
| Percolate | - | கசிதல் / ஊறுதல் |
| Agitate | - | கிளர்ச்சி செய் |
| Disinfectant | - | கிருமி நாசினி |
| Contamination | - | கலப்படம் |
| Water softening | - | தண்ணீர் மென்மை |
| Corrosion | - | அரித்தல் / துருப்பிடித்து வீணாதல் |
| Incrustation | - | மேலேடு பதிவு |
| Lather | - | நுரை |
| Stagnation | - | தேக்கம் |

| | | |
|--------------|---|--------------------|
| Distribution | - | விநியோகம் |
| Impurities | - | அசுத்தங்கள் |
| Bacteria | - | நுண்ணுயிரி |
| Pumping | - | உந்தி / இறைத்தல் |
| Valve | - | அடைப்பான் / கவாடம் |

UNIT - 5

| | | |
|------------------------|---|---|
| Sanitation | - | சுகாதாரம் |
| Disposal | - | வெளியேற்றுதல் |
| Human excreta | - | மனிதக் கழிவு |
| Sewer | - | கழிவு நீர் குழாய் |
| Sewage | - | கழிவு நீர் |
| Sewerage | - | கழிவு நீர் அகற்றும் முறை |
| Dry weather flow | - | கோடைகால கழிவு நீரோட்டம் |
| Wet weather flood | - | மழைகால கழிவு நீரோட்டம் |
| Sludge | - | சாக்கடை சகடு |
| Gradient | - | நீள்வாட்ட சரிவு |
| Ventilation | - | காற்றோட்டம் |
| Detention period | - | தேக்க நேரம் |
| Self cleaning velocity | - | தானே சுத்தப்படுத்திக் கொள்ளும் திசைவேகம் |
| Disinfection | - | கிருமிகளை அழித்தல் |
| Septic tank | - | நச்சுத்தடைத் தொட்டி |
| Soak pit | - | உறிஞ்சு குழி |
| Solid waste management | - | திடக் கழிவு மேலாண்மை |
| Pollutant | - | மாசுபடுத்தும் காரணி |

UNIT 6

| | | |
|------------|---|----------------|
| Expressway | - | விரைவுச்சாலை |
| Subgrade | - | கீழ் அடித்தளம் |
| Formation | - | கட்டமைப்பு |

| | | |
|----------------------|---|--------------------------|
| Sub-base | - | கீழ்தளம் |
| Base course | - | அடித்தளம் |
| Wearing course | - | தேய்மானக் காப்பு அடுக்கு |
| Camper | - | மேல் வாட்ட வலைவு |
| Super elevation | - | மிகை உயர்வு |
| Sight distance | - | காட்சி தூரம் |
| Gradient | - | சாலை சரிவு |
| Road curves | - | சாலை வளைவு |
| Road aggregates | - | சாலை திரளைகள் |
| Toughness | - | இயல்பு கட்டுறவு |
| Hardness | - | கடினத் தன்மை |
| Durability | - | உழைக்கும் தன்மை |
| Adhesion | - | ஒட்டும் பண்பு |
| Bitumen | - | தார் |
| Berms | - | கரை விளிம்பு |
| Centrifugal force | - | மைய விலக்கு விசை |
| Earth road | - | மண் சாலை |
| Water bound mecada | - | நீர்பினை மெக்காடம் சாலை |
| Bituminous road | - | தார் சாலை |
| Cement concrete road | - | சிமெண்ட் கற்காரை சாலை |
| Belting | - | வார் கொண்டு இழுத்தல் |
| Soil stabilization | - | மண் நிலைபடுத்துதல் |
| Road signs | - | சாலை சைகைக் குறிகள் |
| Road signals | - | சாலை சமிக்ஞைகள் |
| Mandatory signs | - | சீராக்கும் சைகைக்குறிகள் |
| Cautionary signs | - | எச்சரிக்கை சைகைக்குறிகள் |
| Informatory signs | - | தகவல் சைகைக்குறிகள் |
| Road arboriculture | - | சாலையோர மர வேளாண்மை |
| Aesthetic | - | அழகுணர்ச்சி சார்ந்த |

| | | |
|------------------|---|------------------------------|
| Highway lighting | - | நெடுஞ்சாலை விளக்கு |
| Luminaries | - | இயற்கை ஒளி கொடுக்கும் பொருள் |
| Staggered | - | எதிர் எதிரான |

UNIT 7

| | | |
|-------------------|---|--------------------|
| Hydraulics | - | நீரியல் |
| Fluids | - | பாய்மம் |
| Density | - | அடர்த்தி |
| Specific Weight | - | பருமனெடை |
| Specific gravity | - | ஒப்படர்த்தி |
| Cohesion | - | ஒட்டுந்தன்மை |
| Adhesion | - | ஒட்டுதல் |
| Surface tension | - | பரப்பு இழுவிசை |
| Capillarity | - | நுண்புழைமை |
| Viscosity | - | பாகுத்தன்மை |
| Thrust | - | உந்துதல் |
| Resistance | - | எதிர்ப்பு |
| Steady flow | - | நிலையான ஓட்டம் |
| Unsteady flow | - | நிலையற்ற ஓட்டம் |
| Laminar flow | - | ஒழுங்கு ஓட்டம் |
| Turbulent flow | - | கொந்தளிப்பு ஓட்டம் |
| Potential energy | - | நிலை ஆற்றல் |
| Pressure energy | - | அழுத்த ஆற்றல் |
| Kinetic energy | - | இயக்க ஆற்றல் |
| Orifice | - | திறப்பு (அ) துளை |
| Vena contracta | - | தாரை குறுக்கம் |
| Convergent | - | குவிகிற |
| Divergent | - | மாறுபட்ட |
| Centrifugal force | - | மையவிலக்கு விசை |
| Impeller | - | தூண்டி |

| | | |
|-------------|---|----------------|
| Casing | - | உறை |
| Strainer | - | வடிகட்டி |
| Prime mover | - | முதன்மை இயக்கி |

UNIT 8

| | | |
|-------------------|---|--------------------|
| Disaster | - | பேரழிவு |
| Disrupts | - | பாதிப்பது |
| Influences | - | தாக்கங்கள் |
| Deteriorate | - | மோசமடைந்து |
| Intensity | - | தீவிரம் |
| Proximity | - | அருகாமையில் |
| Seismic | - | நில அதிர்வு |
| Volconic eruption | - | எரிமலை வெடிப்பு |
| Epidemic | - | தொற்று நோய் |
| Propagating | - | பெருகக்கூடிய |
| Tectonic plates | - | கண்டத்தட்டு |
| Lurching | - | பாய்ந்துள்ள |
| Avalanches | - | பனிப்பாறை சரிவுகள் |
| Tornadoes | - | சுழற்காற்று |
| Terrorist | - | பயங்கரவாத |
| Collision | - | மோதல் |
| Perceired | - | உணரப்பட்ட |
| Stampede | - | நெரிசல் |
| Destructive | - | அழிவு |

Class XII – Basic Civil Engineering Theory & Practical

List of Authors and Reviewers

Academic Advisor & Expert

Dr. P. Kumar
Joint Director (Syllabus),
State Council of Educational Research and Training,
Chennai.

Domain Experts

Mr. R. Balasubramanian
Lecturer (Sel. Gr.)
Dept. of Civil Engineering,
P.T. Lee Chengalvaraya Naicker Polytechnic College,
Vepery, Chennai.

Mrs. Balasubramanian Malathi
Lecturer,
Dept. of Civil Engineering,
P.T. Lee Chengalvaraya Naicker Polytechnic College,
Vepery, Chennai.

Reviewer

Dr. K. Chinnaraju
Professor,
College of Engineering,
Anna University, Guindy,
Chennai.

Authors

Mr. A. Sivanesan
Vocational Teacher,
Govt. Hr. Sec. School,
Agasteeswaram, Kanyakumari.

Mr. N. Rozario Victor
Instructor,
V.V.R. Govt. Tech. Hr. Sec. School,
Lawspet, Puducherry.

Mr. C. Babu
Vocational Teacher,
Govt. Girls. Hr. Sec. School,
Fort, Salem.

Mr. K. Thiyagarajan
Vocational Teacher,
NLC Girls Hr. Sec. School,
Block 11, Neyveli 3.

Academic Coordinator

P. Malarvizhi
B.T. Assistant, (Mathematics),
SCERT, Chennai-06

Art and Design Team

Layout Designing and Illustration)

Udhaya Info, Chrompet, Chennai

Wrapper Design

Kathir Arumugam

Quality Control

Arun Kamaraj Palanisamy
V.S. Johnsmith

Coordination

Ramesh Munisamy

QR Code Management Team

R. Jaganathan
S.G. Asst., (SPOC)
PUMS Ganesapuram - Polur, Thiruvannamalai Dist.

J.F. Paul Edwin Roy
B.T. Asst.,
PUMS Rakkipatti, Veerapandi, Salem Dist.

S. Albert Vallavan Babu
B.T. Asst.,
GHSS Perumalkoil, Paramakudi, Ramanadhapuram Dist.

This book has been printed on 80 G.S.M.
Elegant Maplitho paper.

Printed by offset at:



NOTES





NOTES

