



GOVERNMENT OF TAMILNADU

HIGHER SECONDARY SECOND YEAR

GEOGRAPHY

A publication under Free Textbook Programme of Government of Tamil Nadu

Department of School Education

Untouchability is Inhuman and a Crime

Government of TamilNadu

First Edition - 2019

Revised Edition - 2020, 2022

(Published under new syllabus)

NOT FOR SALE

Content Creation



State Council of Educational
Research and Training

© SCERT 2019

Printing & Publishing



Tamil Nadu Textbook and Educational
Services Corporation

www.textbooksonline.tn.nic.in

CONTENTS

GEOGRAPHY

UNIT	HEADING	Page No	MONTH
1	Population Geography	1	June
2	Human Settlements	22	June
3	Resources	41	July
4	Economic Activities	62	August
5	Cultural And Political Geography	86	September
6	Geoinformatics	110	October
7	Sustainable Development	130	October
8	Man-Made Disasters - Public Awareness For Disaster Risk Reduction	145	November

PRACTICAL

9	Surveying	159	July
10	Map Projection	164	August
11	Thematic Mapping	177	August
12	Representation Of Geographical Data	186	November
13	Statistical Techniques	195	December



E-book



Assessment

HOW TO USE THE BOOK.....

Unit Overview

Provides the major components of the unit to be learned.

Introduction

The subject to be discussed in the lesson is introduced

Do You Know ?

Provides additional information related to the subject in boxes to stir up the curiosity of students.

Learning Objectives

At the beginning of each lesson it provides the scope of lesson.



Case Study

Provides detailed account of an aspect related to the topic .

QR Codes
Given to make content more interesting and dynamic in nature to enhance thinking skills.

HOTS
Motivate the students to think higher order

Glossary
The highlighted key terms at the end of the lesson for conceptual clarity.

GLOSSARY

- Mineralogy:** The study of minerals that exist everywhere.
- Ubiquitous resource:** resources which exist everywhere.
- Alloy:** a metal made by combining two or more metallic elements, especially to give greater strength or resistance to corrosion.
- Lodes:** a vein of metal ore in the earth.

Reference

1. Geography, Surender Singh.
2. Economic and commercial Geography

ICT CORNER
Modern Tools of Geography

Explore and survey geography using modern tools.

Steps

- Long press the scale icon and it will transform into 'Area mode'. Follow the same step to drop the balloon and survey the area between any numbers of points.
- Touch the menu navigation button from the top left corner and change the map style you want to survey.

Step 1: [Image of app interface]

Step 2: [Image of app interface]

Step 3: [Image of app interface]

Step 4: [Image of app interface]

Website URL: <https://www.google.com/maps/@12.9165954,77.6369273,15z>

*Pictures are indicative only.

21 Population Geography

Reference
References and web resources have been provided for getting additional information.

ICT Corner
The access to digital resources on the content through linkage with a specialised app providing scope for students to learn.

Fact File
Qatar-Males per 100 females (306.6)
With an astounding ratio of 306.6 males to a 100 females, Qatar holds the number one spot among countries with the highest male to female ratio in the world in 2018.

As of 2014, the global sex ratio at birth is estimated at 107 boys to 100 girls (1000 boys per 934 girls).

The sex ratio of India is 933 females for every 1000 males according to 2011. Kerala has the highest sex ratio in the country with 1084 females for 1000 males followed by Puducherry with 1037 females for 1000 males and Tamil Nadu with 996 females for 1000 males.

DO YOU KNOW?
Cisgender (often abbreviated to simply cis) is a term for people whose gender identity matches the sex that they were assigned at birth. It is the opposite of the term transgender.

What Are Population Age Pyramids?
Population pyramids are graphical representations of the age and sex of a population. For this reason, population pyramids are also referred to as age-sex pyramids because they are usually shaped like triangles and population pyramids also take

other shapes. Population pyramids usually have males on the left side and females on the right. There is also a vertical line in the middle of the graph that separates the males from the females.

Fact File
Latvia, country with the highest sex ratio in the world.
Latvia is a former Soviet Union country and experienced a great decline in male population during World War two. By 2015, there were 84.8 males for every 100 females. The proportion of the female was 54.10% of the total population. Men in Latvia have a high mortality rate due to issues such as alcoholism, smoking, and careless car driving. Around 80% of suicides in Latvia are committed by men, often because of unemployment and unrealized financial goals. Women enjoy a longer life expectancy living 11 years more than men.

Literacy Rate
Total number of literate persons in a given age group, expressed as a percentage of the total population in that age group.

Literacy rates continue to rise from one generation to the next. Yet according to new data from the UNESCO Institute for Statistics, there are still 750 million illiterate adults, two-thirds of whom are women. These numbers are a stark reminder of the work ahead to meet Sustainable Development Goals (SDGs) 4 and 5 and the Education 2030 targets.

HOT
Why has Singapore the highest physiological/nutritional density of population in the world?

Fact File
Gives information in short and expresses connection with other areas of interests.

CAREER GUIDANCE FOR GEOGRAPHY ASPIRANTS



NRSC

Geographers in State and Central Government Agencies

- Census of India Offices in different States.
- National Remote Sensing Centre (NRSC), Hyderabad.
- Survey of India (Sol), Dehra Dun and in different States.
- National Atlas and Thematic Mapping Organization (NATMO), Kolkata.
- Regional Planning/Town and Country Planning Organisations.
- Naval Hydrographic Office, Dehra Dun.
- National Centre for Earth Science Studies, Thiruvananthapuram.
- Centre for Water Resources Development and Management, Kozhikode.
- Central Arid Zone Research Institute, Indian Council of Agricultural Research, Jodhpur.
- Central Research Institute for Dry Land Agriculture (ICAR), Hyderabad.
- National Bureau of Soil Survey and Land Use Planning (NBSS&LUP), Nagpur.
- French Institute of Pondicherry, Puducherry.
- National Institute of Malaria Research, (ICMR), New Delhi.



IMD

Organisations Supplying Special Publications / Databases and Impart Trainings to Geographers

- Remote Sensing: Publications and Public Relations Unit, ISRO HQ, AntarikshBhavan, New BEL Road, Bangalore-560 094; NRSC Data Centre, National Remote Sensing Centre, Balanagar, Hyderabad-500 037; Remote Sensing Applications Group, Space Application Centre, SAC Post, Ahmedabad- 380 053; Indian Institute of Remote Sensing, 4-Kalidas Road, Dehradun- 248 001.
- Cyclone, Rainfall and Weather Information: Indian Meteorological Department, Nungambakam, Chennai – 600 006.
- Survey of India - Topographic Sheets: Map Sales Office, Electronic Complex - Block II Ground Floor, Thiru. Vi. Ka. Industrial Estate, Guindy, Chennai – 600032.
- Geology and Minerals: Department of Geology and Mining, Thiru. Vi. Ka. Industrial Estate, Guindy, Chennai - 600 032; Geological Survey of India, No A 2 -B Rajaji Bhavan, Besant Nagar, Chennai – 600090.
- Surface and Groundwater and Climate Data: Office of the Chief Engineer, State Ground and Surface Water Resources Data Centre, Tharamani, Chennai - 600 113; Central Ground Water Board. <http://www.india-wris.nrsc.gov.in>
- Soil Data and Maps: Regional Head, ICAR-NBSS&LUP, P.B.No. 2487, Hebbal, Agricultural Farm, Post, Bengaluru - 560 024.
- Rainfall, Landuse, Irrigation and Crop Data: Village / Block/Taluk level Data available at Department of Economics and Statistics, All District Headquarters; Department of Economics and Statistics, 259, Block II, DMS Compound, Teynampet, Chennai-600006.
- Soil, Rainfall and Weather Data: Agro Climate Research Centre, Tamil Nadu Agricultural University, Coimbatore – 641003. <http://tawn.tnau.ac.in/General/HomePublicUI.aspx>
- Population Data: Census of India - Tamil Nadu, 'E' Wing, 3rd Floor, Rajaji Bhawan, Besant Nagar, Chennai – 600090. <http://censusindia.gov.in/>
- Economic Appraisals & Annual Statistical Abstracts of Tamil Nadu: Stationery and Printing Department, 110, Anna Salai, Chennai-600002. <http://www.stationeryprinting.tn.gov.in>
- Soil and Watershed Atlas: Remote Sensing Centre, Agriculture Engineering Department, Nandanam, Chennai - 600 035. <http://www.aedatlas.tn.nic.in>
- GIS Data Layers of Tamil Nadu: Tamil Nadu Geographical Information System (TNGIS), Chepauk, Chennai – 600 005. <http://www.tngis.tn.gov.in>



UPSC

UPSC

Competitive examinations comprising Geography subject matter are listed below



- UPSC civil service examinations conducted by Govt. of India.
- Tamilnadu Public Service Commission Group services Examinations conducted by Govt. of Tamilnadu.
- Teachers Recruitment Board, School education and Collegiate education, Govt. of Tamilnadu.



TNPSC



TRB



UM

Universities and Colleges Offering B.Sc., M.Sc., in Geography and M. Tech Programme in Geoinformatics in Tamil Nadu

- Department of Geography, University of Madras, Chepauk, Chennai – 600 005.
- Department of Geography, Madurai Kamaraj University, Madurai - 625 021.
- Department of Geography, Bharathidasan University, Tiruchirappalli - 620 024.
- Department of Geography, Central University of Tamil Nadu, Thiruvarur – 610 005.
- Department of Environmental Remote Sensing and Cartography, Madurai Kamaraj University, Madurai - 625 021.
- Department of Geography, Presidency College (Autonomous), Chennai – 600 005.
- Department of Geography, Queen Mary's College (Autonomous), Chennai - 600 004.
- Department of Geography, Bharathi Women's College (Autonomous), 85, Prakasam Salai, Chennai-600 108.
- Department of Geography, Tourism and Travel Management, Madras Christian College (Autonomous), Tambaram, Chennai - 600 059.
- Department of Geography, Government Arts College (Autonomous), Salem – 636 007.
- Department of Geography, Sri Vijay Vidyalaya College of Arts and Science, Nallampalli, Dharmapuri – 636807.
- Department of Geography, Arignar Anna Government Arts College, Namakkal – 637002.
- Department of Geography, Government Arts College (Autonomous), Coimbatore - 641 018.
- Department of Geography, Nirmala College for Women (Autonomous), Coimbatore – 641 018.
- Department of Geography, Bharathiar University Arts & Science College, Amaikulam, PulliamParai (P.O.), Gudalur - 643 212.
- Department of Geography, Government Arts College (Autonomous), Karur – 639 005.
- Department of Geography, Periyar E.V.R. College (Autonomous), Tiruchirappalli – 620 023.
- Department of Geography, Government Arts College, Thiruverumbur, Tiruchirappalli – 620 022.
- Department of Geography, Kundavai Nachiar Government Arts College for Women (Autonomous), Thanjavur - 613 007.
- Department of Geography, A.V.V.M Sri Pushpam College (Autonomous), Poondi - 613 503, Thanjavur District.
- Department of Geography, Government Arts College (Autonomous), Kumbakonam- 612 002.
- Department of Geography, Government Arts College for Women (Autonomous), Kumbakonam - 612 002.
- Department of Geography, SriMeenakshi Government Arts College for Women (Autonomous), Madurai – 624 002
- Department of Geography, MVM Government Arts College for Women, Dindigul - 624 008..
- Department of Geography, Government Arts College for Women, Niliakottai - 624 208, Dindigul District.



UNIT 1

Population Geography



Unit Overview

- 1.1 Introduction
- 1.2 Distribution of World population
- 1.3 Density of Population
- 1.4 Growth of world population
- 1.5 Composition of Population
- 1.6 Migration
- 1.7 Overpopulation
- 1.8 Measures to control overpopulation

1.1. Introduction

Do you know that 3,60,000 persons born every day in the world? Four births take place every second in the world. 'Professor Stephen Hawking thinks the human species will have to populate a new planet within 100 years if it is to survive,' the BBC confirmed.

'With climate change, overdue asteroid strikes, epidemics and population growth, our own planet is increasingly precarious,' the news outlet continued.

Human being is an important element of the environment and is probably the latest occupant of the earth, as its evolution took place less than two million years ago. Although distribution and growth of human population are influenced greatly by the physical environment, they have tremendous capacity to modify the physical environment. **Demography** is the statistical

Learning Objectives

- Know the attributes of population.
- Understand the distribution of the world population.
- Judge the cause and effect of population growth.
- Estimate the problems of over population.
- Elucidate the pull and push factors of migration.



study of human population. It includes the study of size, structure and distribution of population as well as changes in time and location in response to birth, migration, aging and death. '**Population explosion**' is one of the greatest challenges that we are facing today.

1.2 Distribution of world population

People have inhabited the earth for several thousands of years, but for a long period of time, their numbers remained limited. It is only during last few hundred years that human population has increased at an alarming rate.

Population is spread unevenly across the continents. Only a few areas support large

concentration of people while vast areas support few people. A large number of factors influence the distribution and growth of population over the earth's surface.

The factors influencing the distribution of population

1. Relief

Rugged mountains pose various obstacles such as unsuitable conditions for the construction of rail-roads and highways, unfavourable conditions for agricultural crops because of short growing season, lack of cultivable land and snowy winters do not encourage large settlement areas. Hence, the mountainous areas support a few people. On the other hand, a large concentration of population is found in the fertile lowlands such as the Ganges and Brahmaputra in India, Hwang-Ho in China and plains of North-Western Europe and the USA. This is mainly due to flat level land which is fertile, favourable conditions for agriculture, long growing seasons and suitable condition for the settlement.

2 Accessibility

Areas with well developed transport infrastructure and links through road, rail, shipping, canals and air are likely to be more densely populated than areas which are poorly connected with transport network.

In earlier times, in the absence of water transport, all islands remained virtually uninhabited. One of the reasons why mountains are not inhabited by people is lack of accessibility.

3. Adequate water supply

Population distribution is affected very much by the presence or absence of water in any region. Water supply is essential for human survival and development. Areas which have sufficient water tend to have denser population

than areas which are dry or suffer from regular drought. Well watered regions of the Great Northern plains of India are densely populated whereas drought prone areas of Sahara are sparsely populated.

4. Soil

Fertile alluvial soils of river valleys throughout the world have encouraged dense settlement of population because they support agricultural activities. The high density of population in parts of East and South-East Asia is dependent mainly on fertile soil. For example, dense population is found in the Ganges valley of India, in Indus valley of Pakistan and Hwang-Ho valley of China. On the other hand, desert soil of Sahara region is sparsely populated.

5. Economic and political factors

Unfavourable economic condition, unemployment, religious intolerance, conflicts and wars do not favour more population.

The patterns of Population Distribution

The analysis of the pattern of population distribution and density is fundamental to the study of demographic characteristics of any area. The population distribution refers to the way the people are spread over the earth's surface. The population distribution is uneven worldwide. **Ten most populous countries** of the world together make up nearly **60%** of the world's population.

1.3 Density of Population

Absolute numbers do not give any indication of the impact of population on the land and its resources. The number of persons living per unit of land areas gives a better picture. This is expressed in the form of density of population per sq.km of land area.

$$\text{Density of population} = \frac{\text{Total population}}{\text{Total area of the country}}$$

It is obtained by dividing the total land area by the total population, the quotient being the number of people per square kilometre. Compared with simple arithmetic density, physiological or nutritional density is a more refined method of calculating man-land ratios.

Physiological or Nutritional density is the ratio between total population and total cropped area. The total arable land in the world is **13.3%** and the nutritional density of the world is **325 per sq.km** of land. The total percentage of arable land is 48.83 in India and its nutritional density is 753 per sq.km of land. **Singapore** has the highest nutritional density of population of **440,998 per sq.km** of land the world. The areas of density of population can be divided into three as follows:

1. High density areas of population

Fertile plains with favourable climate and highly industrialised and urbanised areas are generally densely populated. There are four major areas of high density of population with **more than 100 persons** per sq.km. Areas include:

- Eastern Asia, including china, Japan and Republic of Korea.
- Southern Asia, comprising India, Bangladesh and Sri Lanka.
- North-Eastern part of the United States of America.
- Central and North-Western Europe.

Of the four regions given, the first two i.e. Eastern Asia and South Asia have high density of population due to favourable environmental conditions such as favourable climate, fertile soil and large areas of plains which encourage the growth of agriculture. The plains and river valleys of India and China are densely populated. In the last two groups i.e. North Eastern United States of America and North – Western Europe

which are densely populated due to the concentration of manufacturing industries.

HOTS

Why has Singapore the highest physiological/nutritional density of population in the world?

2. Moderate density areas of population

The areas of moderate density of population have **between 10 and 80 persons** per sq.km. The areas of moderate density of population include Central part of the United States of America, Tropical Western Africa, Western blocks of Russia, Eastern Europe, Deccan Plateau of India, Central China, Southern portion of the Plateau of Mexico, North-Eastern Brazil and Central Chile, The above areas are characterised by the well developed agricultural activities, favourable climate, fertile soils, fishing, etc.,

3. Low density areas of population

About half the area of the world has population **less than 10 persons** per sq.km. Certain vast areas remain completely uninhabited. The main areas are

- Amazon forest region of South America and Congo forest region of Africa.
- Arctic area of Canada, Greenland and the Polar regions.
- Great deserts of the world i.e. Sahara, Kalahari, Arabia, Great desert of Australia, Atacama Desert of South America, desert regions of Western United States and Thar Desert of India.
- High mountainous regions in all continents.
- Antarctica.

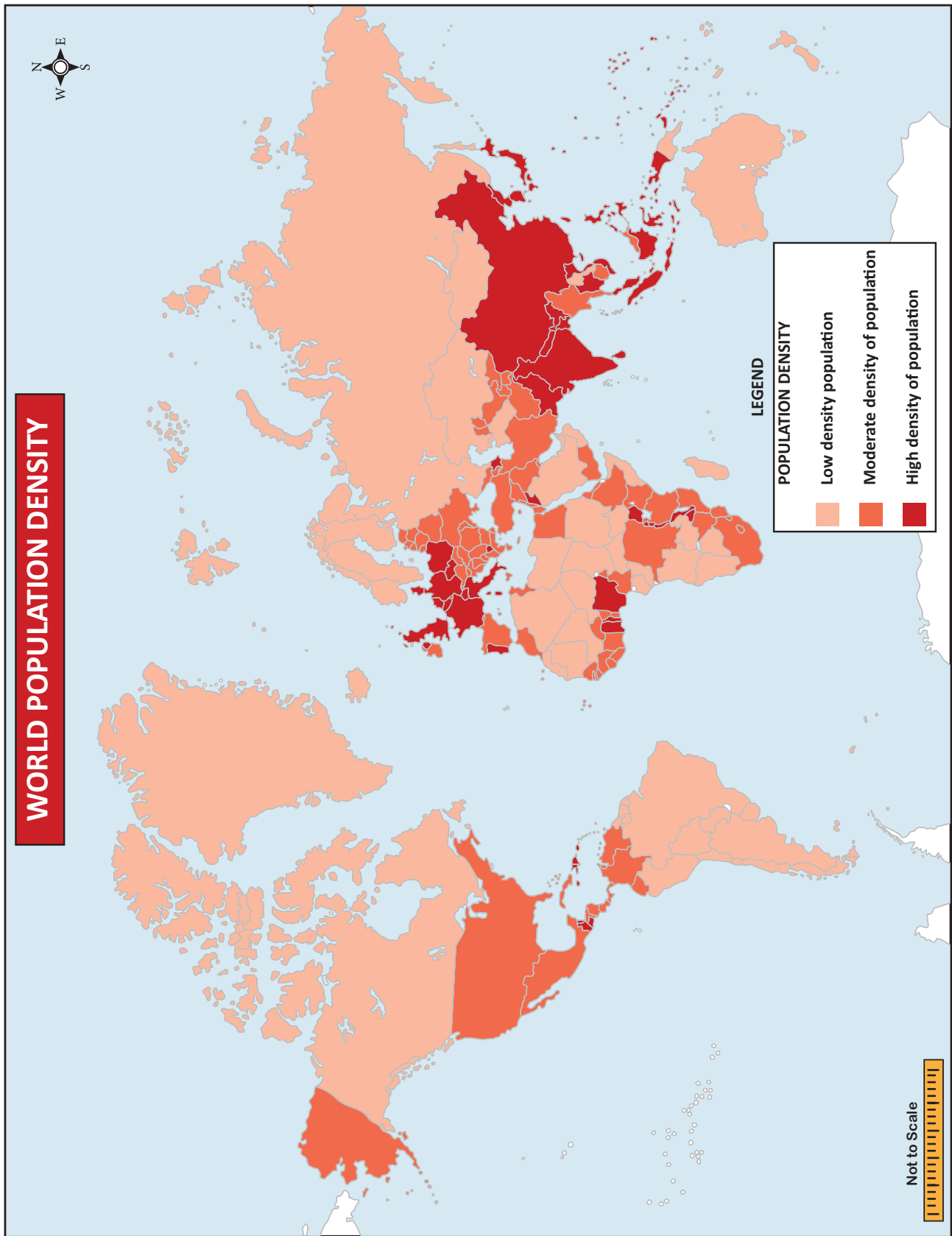

Australia with an average density of population of **2 persons per sq.km** is one of the most sparsely populated countries of the world. However, inhabitants of these areas have high standard of living. **The reasons for low density of population are:**

- Bad and unfavourable environment conditions for human settlement.
- Lack of economic activities.
- Lack of transport and communication.
- Government policy.

Terms related population

- Population:** A group of individuals of the same species occupying a particular geographic area.
- People:** The members of a particular nation, community, or ethnic group.
- Crude Birth rate (Nativity Rate):** Number of live births per thousand people in a year.
- Crude Death Rate (Mortality Rate):** Number of deaths per thousand people in a year.
- Net Migration Rate:** the formula for net migration rate is simple:

$$N = 1000 \times (I - E) / P$$
 N= net migration rate
 E= number of people emigrating out of the country
 I= number of people immigrating into the country
 P= the estimated mid-year population
- Fertility Rate:** is the number of live births expected per 1000 women in their life times in a specified geographic area and for a specific point in time, usually a calendar year. **Niger** has the **highest fertility rate of 6.49** while **Singapore** has the **lowest fertility rate of 0.83**. Can you guess why there is variation between these countries?

7. Dependency ratio:

Number of dependents in a population divided by the number of working age people. It's a calculation which groups those aged under 15 with those over 65 years as the 'dependants' and classifying those aged 15-64 years as 'the working-age population'.

8. **Growth Rate:** = CBR - CDR +/- Net Migration Rate/ 1000

South Sudan has the highest population growth rate of 3.83% in 2017.

9. **Rate of Natural Increase (RNI)** = CBR-CDR (No Migration)

CBR>CDR = ↑ population

RNI usually expressed as %
 e.g., 2% = 2/100 = 20/1000

RNI ≠ population growth if migration significant

10. **Adult Literacy Rate:** The Adult literacy index (ALI) is a statistical measure used to determine how many adults can read and write in a certain area or nation. Adult literacy is one of the factors in measuring the Human Development Index (HDI) of each nation, along with life expectancy, education, and standard of living. Burkina faso has the lowest literacy rate of 21.8% (2015). How does literacy rate affect the standard of living of a country?

11. **Life expectancy rate:** Life expectancy equals the average number of years a person born in a given country is expected to live. As of 2015, the country with the highest life expectancy is Monaco at 89.52 years; the country with the lowest is Chad at 49.81 years.

1.4 Growth of world population

After the introduction of agriculture about 8,000 to 12,000 years ago, the size of population was small, roughly 8 million. In the first century (C.E) it was below 300 million. The expanding world trade during the sixteenth and seventeenth century, set the stage for rapid population growth. Around 1750, at the dawn of Industrial Revolution, the world population was 550 million. World population exploded in the eighteenth century after the Industrial Revolution. Technological advancement achieved so far helped in the reduction of birth rate and provided a stage for accelerated population growth.

The current **world population of 7.6 billion** is expected to reach 8.6 billion in 2030, 9.7 billion in 2050 and 11.2 billion in 2100, according to a new United Nations report being launched. With roughly **83 million people being added to the world's population every year**, the upward trend in population size is expected to continue, even assuming that fertility levels will continue to decline.

The current world population, according to UN Department of Economic and Social Affairs, Feb, 2019, is 7,685,036,620.



The new projections include some notable findings at the country level. **China (with 1.4**

billion inhabitants) and India (1.3 billion inhabitants) remain the two most populous countries, comprising 19% and 18% of the total global population respectively. In roughly seven years, or around 2024, the population of India is expected to surpass that of China.

Among the ten largest countries worldwide, **Nigeria** is growing the most rapidly. Consequently, the population of Nigeria, currently the world's 7th largest, is projected to surpass that of the United States and become the third largest country in the world shortly before 2050.

Most of the global increase is attributable to a small number of countries.

From 2017 to 2050, it is expected that half of the world's population growth will be concentrated in just nine countries: India, Nigeria, Congo, Pakistan, Ethiopia, the United Republic of Tanzania, the United States of America, Uganda and Indonesia (ordered by their expected contribution to total growth).

The group of 47 least developed countries (LDCs) continues to have a relatively high level of fertility, which stood at 4.3 births per woman in 2010-2015. As a result, the population of these countries has been growing rapidly, at around 2.4 % per year. Although this rate of increase is expected to slow significantly over the coming decades, the combined population of the LDCs,

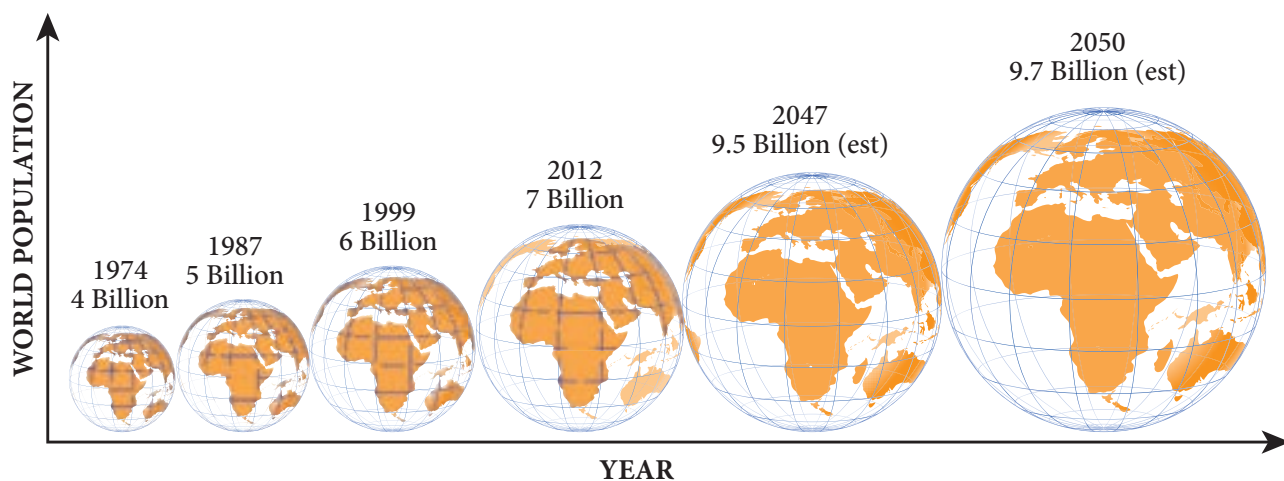

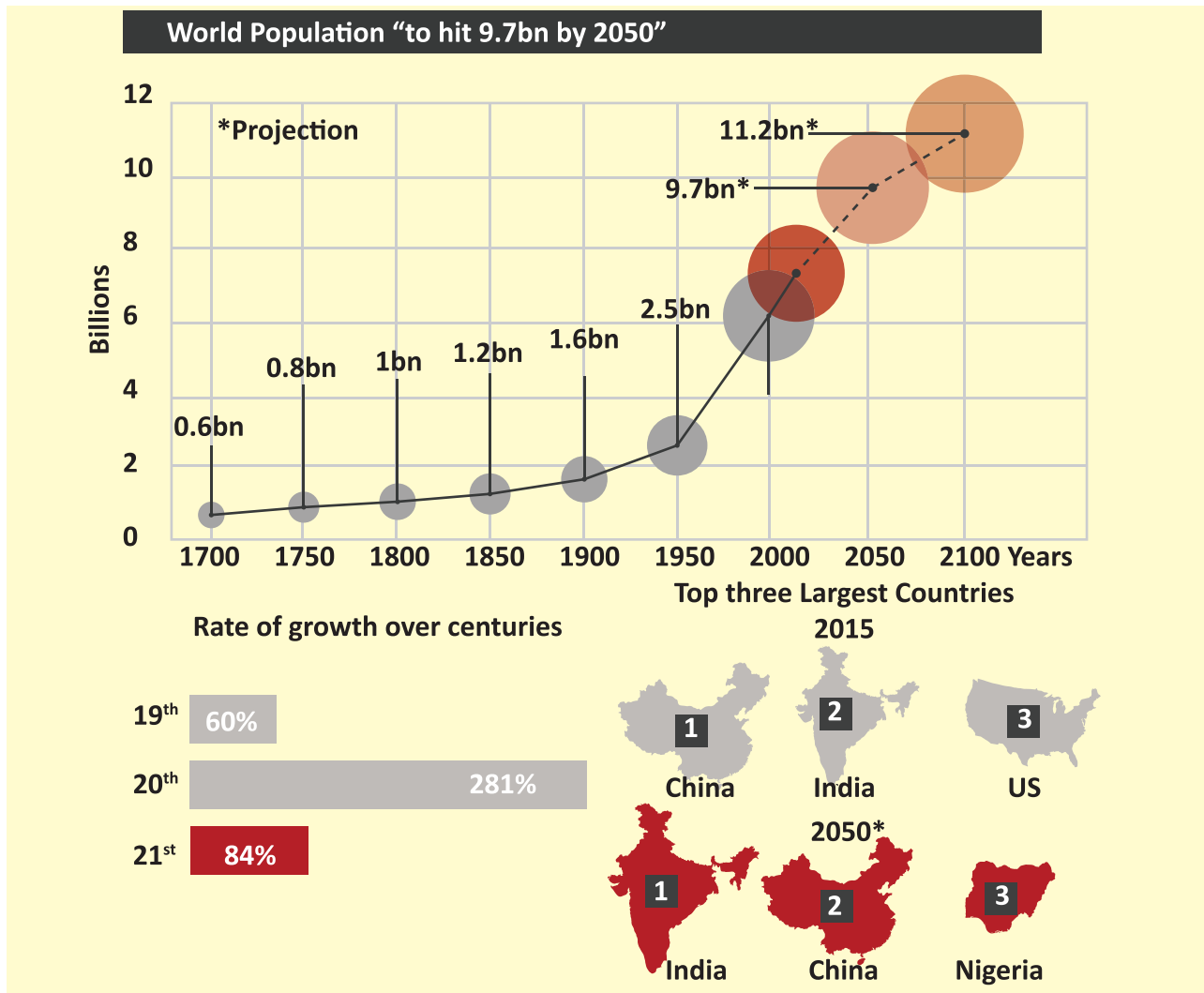

roughly one billion in 2017, is projected to increase by 33 % between 2017 and 2030, world population will reach 9.7 billion in 2050.

Similarly, Africa continues to experience high rates of population growth. Between 2017 and 2050, the populations of 26 African countries are projected to expand to at least double their current size.

The concentration of global population growth in the poorest countries presents a considerable challenge to governments in implementing the 2030 Agenda for Sustainable Development, which seeks to end poverty and hunger, expand and update health and education systems, achieve gender equality and women's empowerment, reduce inequality and ensure that no one is left behind.

Population in the world is currently (2019) growing at a rate of around 1.09% per year (down from 1.12% in 2017 and 1.14% in 2016). It is estimated to reach 1% by 2023, less than 0.5% by 2052, and 0.25% in 2076. In 2100, it should be only 0.09% or an addition of only 10 million people to a total population of 11.2 billion. World population will, therefore, continue to grow in the 21st century.

Doubling Time of population

Doubling time is the amount of time it takes for a given quantity of population to double in size at a constant growth rate. We can find the doubling time for a population undergoing exponential growth by using the Rule of 70. It is because the population of a country becomes

double in 70 years if the growth rate is 1%. Thus, we divide 70 by the growth rate and we get the doubling time of population growth rate. For example if the growth rate is 2.08, divide 70 by 2.08 and we get 33.6 years as the doubling time of population.

World population has doubled in 40 years from 1959 (3 billion) to 1999 (6 billion). It is now estimated that it will take another nearly 40 years to increase by another 50% to become 9 billion by 2037. The latest world population projections indicate that world population will reach 10 billion persons in the year 2055 and 11 billion in the year 2088.

World Population Milestones

According to the United Nations, the 6 billion figure was reached on October 12, 1999 (celebrated as the Day of 6 Billion). World population reached 7 Billion on October 31, 2011. The current world population is 7.7 billion as of Feb 2019 according to the most recent United Nations estimates. The United Nations projects world population to reach 8 billion in 2023 and 10 billion in the year 2056.

Regional division on the basis of growth rate

On the basis of the growth rate of population the world can be divided into the following three types of areas:

1. Areas of Low Growth Rate

Developed countries like US, Canada, Japan, Australia, New Zealand and countries of western Europe have a low growth rate of population in these countries is due to low birth rates and low death rates. The difference between the birth rate and the death rate in these countries is the lowest.

2. Areas of Moderate Growth Rate

This category includes the developing countries like Pakistan, Afghanistan, Brazil, Bolivia,

Mongolia, Indonesia and many other Africa and South American countries, where the growth rate of nearly 2 % is also included among these countries though the growth rate here has started declining.

3. Areas of High Growth Rate

Countries like Mexico, Iran, Colombia, Venezuela, Peru, Libya, Algeria, Sudan, Kenya and Kuwait make this category. In fact, most of the African countries with a growth rate of 3% fall in this category.

Population Concepts

- i) **Over population:** situation whereby the population is considered too large for the available resources.
- ii) **Under – population:** a situation where the population is less than the available resources of a country.
- iii) **Optimum – population:** a situation where the number of people that can be supported is the same as the available resources.

Fact File

India - Population

- The current population of India is 1,363,413,725 as of Feb 19, 2019, based on the latest United Nations estimates.
- India population is 17.74% of the total world population.
- India ranks number 2 in the list of countries (and dependencies) by population.
- The population density in India is 455 per Km².(1180 persons/1mile)
- 33.6 % of the population is urban (460,249,853 people in 2019)

1.5 Composition of Population

Composition of Population includes sex ratio, literacy rate, age pyramids etc.

Sex Ratio

The sex ratio is the ratio of males to females in a population.

Fact File

Qatar-315 Males per 100 females (2019)

With an astounding ratio of 315 males to a 100 females, Qatar holds the number one spot among **countries with the highest male to female ratio in the world in 2018.**

As of 2014, the global sex ratio at birth is estimated at 107 boys to 100 girls (1000 boys per 934 girls).

The sex ratio of India is 933 females for every 1000 males according to 2011.

Kerala has the highest sex ratio in the country with 1084 females for 1000 males followed by Puducherry with 1037 females for 1000 males and **Tamil Nadu with 996 females for 1000 males.**



Cisgender (often abbreviated to simply CIS) is a term for people whose gender identity matches the sex that they were assigned at birth. It is the opposite of the term *transgender*.

What Are Population Age Pyramids?

Population pyramids are graphical representations of the age and sex of a population. For this reason, population pyramids are also referred to as **age-sex pyramids**. We refer to these graphs as pyramids because they are usually shaped like triangles and population pyramids also take

other shapes. Population pyramids usually have males on the left side and females on the right. There is also a vertical line in the middle of the graph that separates the males from the females.

Fact File

Latvia, country with the highest sex ratio in the world.

Latvia is a former Soviet Union country and experienced a great decline in male population during World War two. By 2015, there were 84.8 males for every 100 females. The proportion of the female was 54.10% of the total population. Men in Latvia have a high mortality rate due to issues such as alcoholism, smoking, and careless car driving. Around 80% of suicides in Latvia are committed by men, often because of unemployment and unrealized financial goals. Women enjoy a longer life expectancy living 11 years more than men.

Literacy Rate

Total number of literate persons in a given age group, expressed as a percentage of the total population in that age group.

Literacy rates continue to rise from one generation to the next. Yet according to new data from the UNESCO Institute for Statistics, there are still 750 million illiterate adults, two-thirds of whom are women. These numbers are a stark reminder of the work ahead to meet Sustainable Development Goals (SDGs) 4 and 5 and the Education 2030 targets.

CASE STUDY

India's literacy rate is at 74.04%. **Kerala** has achieved a literacy rate of **93.91%**. **Bihar** is the **least** literate state in India, with a literacy of **63.82%**. Several other social indicators of

the two states are correlated with these rates, such as life expectancy at birth (71.61 for males and 75 for females in Kerala, 65.66 for males and 64.79 for females in Bihar), infant mortality per 1,000 live births (10 in Kerala, 61 in Bihar), birth rate per 1,000 people (16.9 in Kerala, 30.9 in Bihar) and death rate per 1,000 people (6.4 in Kerala, 7.9 in Bihar).

Six Indian states account for about 70% of all illiterates in India: Uttar Pradesh, Bihar, Madhya Pradesh, Rajasthan, Andhra Pradesh and West Bengal. Slightly less than half of all Indian illiterates (48.12%) are in the six Hindi-speaking states of Uttar Pradesh, Bihar, Rajasthan, Madhya Pradesh, Jharkhand and Chhattisgarh.

Age - Sex pyramids

There are three types of Age - Sex pyramids: expansive, constrictive, and stationary.

Expansive Age - Sex pyramids depict populations that have a larger percentage of people in younger age groups. Populations with this shape usually have high fertility rates with lower life expectancies. Many third world countries have expansive Age - Sex pyramids. Such a population pyramid is a characteristic of newly developing countries such as Afghanistan, Bangladesh, Kenya, and some countries of Latin America.

Constrictive Age - Sex pyramids are named so because they are constricted at the bottom. There is a lower percentage of younger people. Constrictive Age - Sex pyramids show declining birth rates, since each succeeding age group is getting smaller and smaller. **The United States has a constrictive Age - Sex pyramid.**

CASE STUDY

Tripura literacy success

Presently **Tripura** has the **highest** literacy rate in India, **94.65 percent**. According to the 2011 census, literacy level was 93.91 percent in Kerala and 91.58 percent in Mizoram, among the most literate states in the country. The national literacy rate, according to the 2011 census, was 74.04 percent. The Tripura success story is attributed to the involvement of local government bodies, including Gram panchayats, NGOs and local clubs under the close supervision of the State Literacy Mission Authority (SLMA) headed by the chief minister. Tripura attained 87.75 percent literacy in the 2011 census, from the 12th position in the 2001 census to the 4th position in the 2011 census. Among projects implemented by the state government to increase literacy in the state are

- 10,000 anganwadi centres have 100 percent enrollment.
- Policy of no fail till class VIII to prevent children from dropping out.
- Midday meals in all schools with an eclectic menu for all days of the week to attract more students.
- No tuition fee in government colleges.

The holistic education system, implemented with equal interest in Agartala, remote areas and the tribal autonomic areas makes sure that people in Tripura do not just become literate but educated, officials emphasized. One pointer to the government's interest in education is the near-total absence of child labour in Tripura.

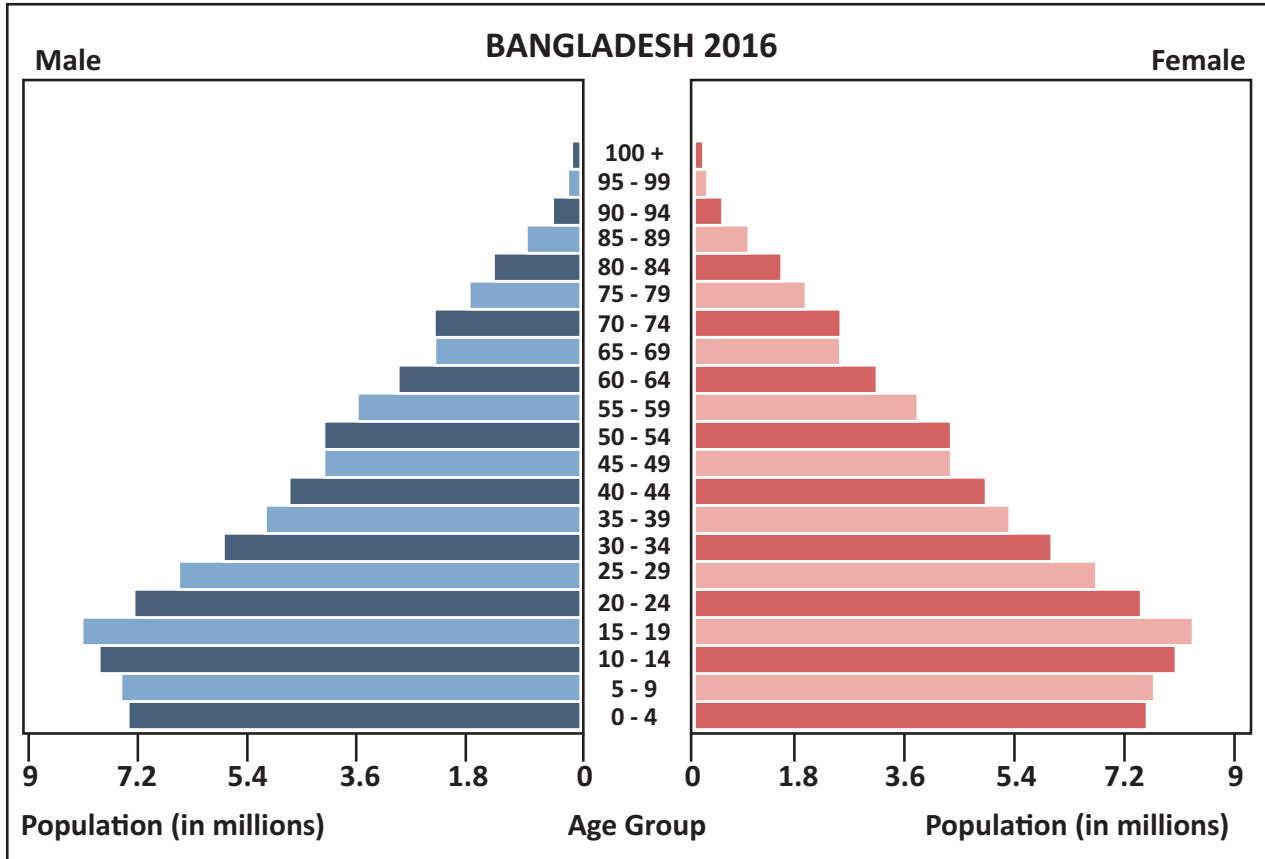

Expansive Age - Sex pyramid

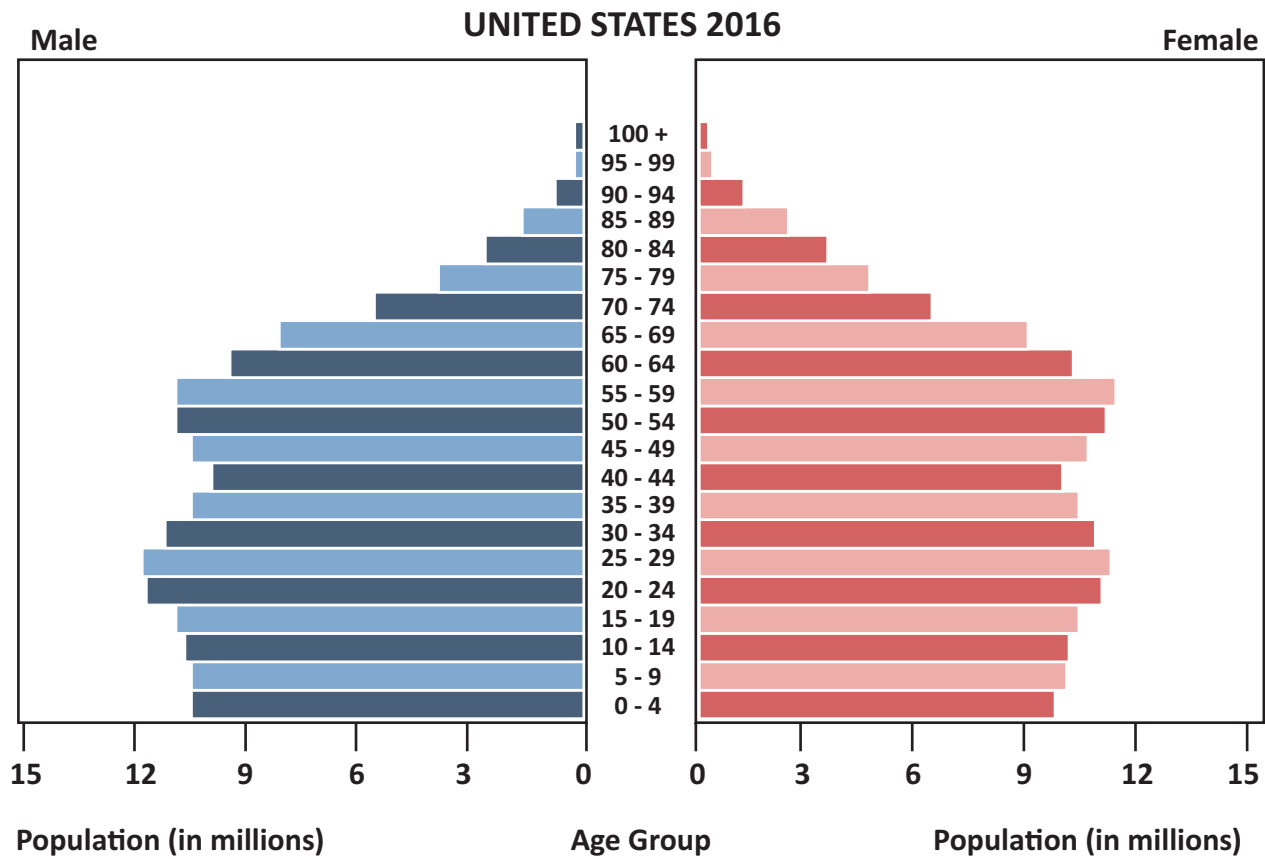

Constrictive Age - Sex pyramid

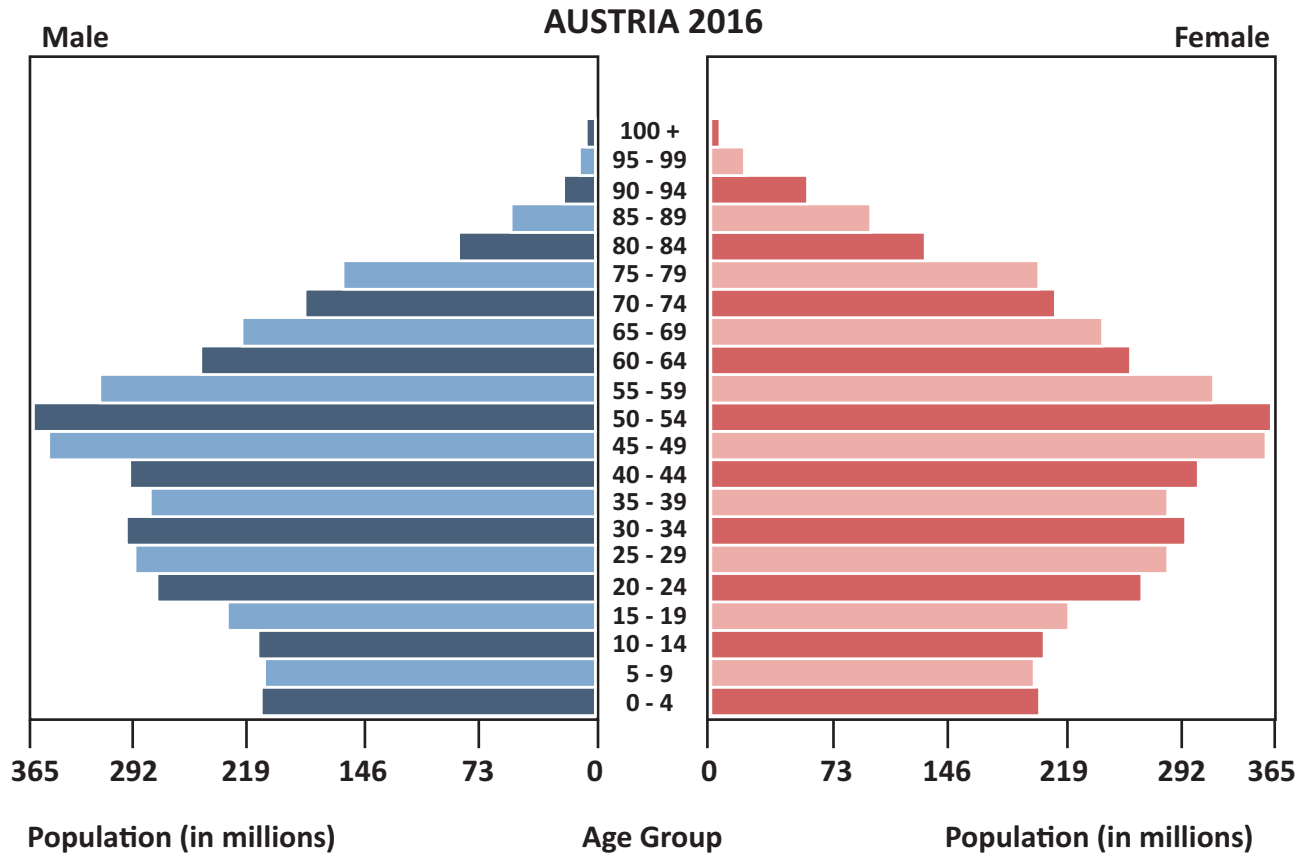

Stationary Age - Sex pyramids are those that show a somewhat equal proportion of the population in each age group. There is not a decrease or increase in population; it is stable. **Austria has a stationary Age - Sex pyramid.**

The Purpose of the Age - Sex Pyramid

The purpose of making this Age - Sex pyramid is to find out the comparison between the number of men and women, the number of workers, and the structure of the population in a country quickly. In addition, the creation of the Age - Sex Pyramid also has a purpose to assist the government in taking development policies.

1.6 Migration

Migration means the movement of people from one place to the other. It is an important control of population growth after fertility and mortality. Migration of people into an area from outside is called immigration or in-migration while movement out of an area to other regions is called emigration or out-migration.

Immigration leads to an increased growth rate of population, emigration lowers the growth rate of population in the source region. Mexico's emigration problem is a unique one, with more than 98% of all Mexican migrants living in the U.S.A, the country with which Mexico shares a border that runs 3110 km in length. The Mexican emigration rate increased substantially since the 1960s and, with more than 11% of Mexicans living abroad, **Mexico is the country with the largest number of emigrants in the world.** According to estimates from the UN 2015 report, in 2013, the **United States, Germany and Russia** had the largest number of immigrants of any country, while **Tuvalu and Tokelau** had the lowest immigrant.

Types of migration

1 Net Migration

Net Migration is the difference between immigration (in-migration) and emigration (out-migration).

Positive value of net migration is that more people coming in and population growth, for example, 44% of North America and 88% of Europe. Negative value of migration is more people going out and population decline.

2 International Migration

Emigration is an indicator of economic and or social failures of a society. It is a crossing of a national boundary. It is easier to control and monitor. There are laws to control or inhibit these movements. Between 2 million and 3 million people emigrate each year. Between 1965 and 2000, 175 million people have migrated: it accounts for 3% of the global population.

3 Internal Migration

It occurs within a country. It is crossing of population within domestic jurisdictional boundaries. It is the movement of people between states or provinces. There is little government control over internal migration.

4 Local Migration

Local migration is the migration of the people within state or district. No state boundaries are crossed in the local migration. It happens for several reasons such as buying a new house in the same town or city, difficult to research since they are usually missed in census data. It is based on change of income or lifestyle. Americans change residence every 5 to 7 years.

5 Voluntary migration

Voluntary migration is where the migrant makes the decision to move. Most migration is voluntary.

6 Involuntary migration

It is a forced migration in which the migrant has no role in the decision-making process. It includes mostly slavery. It is estimated that about 11 million African slaves were brought to the Americas between 1519 and 1867. In 1860, there were close to 4 million slaves in the United States. People involve in the involuntary migration are refugees due to military conscription, children

of migrants, people in the situations of divorce or separation.

Brain Drain

Brain drain is related to educationally specific selective migrations. Some countries are losing the most educated segment of their population. It can be both a benefit for the receiving country and a problem to the country of origin.

Receiving country: it is getting highly qualified labor which is contributing to the economy right away. It promotes economic growth in strategic sectors: science and technology. It does not have to pay education and health costs, for example, 30% of Mexicans with a PhD are in the US.

Country of origin: Education and health costs are not paid back to the country of origin. It is losing potential leaders and talent: Between 15 and 40% of a graduating class in Canada will move to the US. It has long term impact on economic growth. It has the possibility of getting remittances. Many brain drain migrants have skills which they can't use at home: The resources and technology may not be available there. The specific labour market is not big enough.

Causes of Migration

We can divide factors causing migrations into two groups of factors as push and pull Factors.

Push and Pull factors

Push and pull factors are those factors which either forcefully push people into migration or attract them. A push factor is forceful, and a factor which relates to the country from which a person migrates. A pull factor is something concerning the country to which a person migrates. It is generally a benefit that attracts people to a certain place. Push and Pull factors are usually considered as north and south poles on a magnet.



Push Factors: Not enough jobs, few opportunities, desertification, famine/drought, political fear/persecution, poor medical care, loss of wealth, natural disasters, death threats, slavery, pollutions, poor housing, landlords, bullying and poor chances of finding courtship

Pull Factors: job opportunities, better living conditions, political and or religious freedom, enjoyment, education, better medical care, security, family links, industry, better chances of finding courtship.

1.7 Overpopulation

Overpopulation is the state whereby the human population rises to an extent exceeding the carrying capacity of the ecological setting. In an overpopulated environment, the numbers of people might be more than the available essential materials for survival such as transport, water, shelter, food or social amenities. This regularly contributes to environmental deterioration, worsening in the quality of life, or even the disintegration of the population.

Due to immigration, the decline in mortality rates, medical breakthroughs, and increased birth rates, populations will always increase and eventually gives rise to overpopulation.

Impacts of Overpopulation

Overpopulation thus contributes to some of the most compelling environmental problems which encompass:

1. Depletion of Natural Resources

As human population keeps on increasing, exhaustible natural resources such as arable land, coral reefs, fresh water, fossil fuels, and forests continue to drop sharply. This creates competitive demands on the vital life-sustaining resources and contributes to an incredible decline in the quality of life.

2. Accelerated Habitat Loss

The increased loss of the ecosystems including wetlands, wildlife, rainforests, coral reefs, aquatic life forms, and grasslands are highly influenced by overpopulation. For example, rainforests originally covered 14% of the entire earth's surface. Today, rainforest only cover about 6% of the earth's surface and scientists' project it may even become less in the next four decades judged by the current rate of vegetation removal, logging, and deforestation. Besides, due to environmental pollution, 30% of the ocean reefs have been lost because of acidification and global warming since 1980. Also, more than half of the original wetlands have been lost.

3. Amplified Climate Change and Global Warming

The more the number of people, the more the number of vehicles and industries would be. Furthermore, more population tends to increased use of energy sources such as coal and firewood which contributes to increased greenhouse gas emissions.

Hence, because of the accumulation of human generated green house gases and carbon footprint in the atmosphere, the planet has continued to witness amplified global warming and climate change. The effects of climate change and global warming are resulting in extreme hunger, drought, flooding, and loss of habitat.

4. Loss of Biodiversity

Overpopulation has caused encroachment into frontier forests and destruction of natural ecosystems that has led to the mass extinction of species. The number of threatened species persists to multiply in number whereas some have completely gone extinct. This is because of human activities such as acidifying water, over exploitation of natural resources, pollution, over fishing, poaching, and destruction of natural systems which are necessary for the survival of different species.

5. Decrease of fresh water

The unrelenting nature of overpopulation on the earth has destroyed most of the world's fresh water systems. Most of the lakes, streams, rivers and ground water making up fresh water have been polluted. According to the global outlook of water resources, these activities influenced by over population have only left less than 1% of the planet's fresh water readily accessible for human utilization.

Water vulnerability is already affecting many overpopulated nations, especially in some developing countries, as the demands for water tend to be more than the accessible water. Millions of fish species from freshwater ecosystems are on the verge of extinction. Thus, as human inhabitants rise in number, so will the problem of quality freshwater accessibility.

6. Lower Life Expectancy and Diminished Quality of Life

Overpopulation lowers the standards of living since it creates stress on the vital resources for survival and increases the difficulty of accessing the consistent supply of quality food, water, energy, health, security and shelter. Consequently, it makes the poor to become poorer, and they often opt for poor living conditions to survive.

Eventually, it gives rise to lower life expectancy. The situation is serious in developing nations such as southern Asia and sub-Saharan Africa where most of the poor populations submit to inadequate and poor diets.

7. Rise in Unemployment, Crime Rate, and Violence

In overpopulated nations, the available jobs are fewer than the overall job seeking population. This contributes to high levels of unemployment. In turn, lack of employment leads to elevated crime rates because of theft, drug cartels, and militia groups which are exploited as options

for attaining basic resources and necessities such as food, good living standards, and wealth. Violence and conflicts arise when people start competing for the available limited resources.

8. Increased Intensive Farming

As population has grown over the years, farming practices have evolved to produce enough food to feed larger numbers of people. However, intensive farming methods also cause damage to local ecosystems and the land, which may pose problems in the future.

1.8 Measures to control overpopulation

Here are some unique solutions to overpopulation:

1. Creating Awareness Campaigns

Using both social and mainstream media, we can clearly tell people around the world the truth about overpopulation crises and what must be done to solve them the right way.

2. Promotion of Adopting child

Adoption become a consideration for family planning, particularly among socially conscientious communities. And today, it has become a de-facto solution for people who are interested in starting a family, yet having concerns about overpopulation.

3. Aiming for Single-Child Families

According to statistics, hundreds of thousands of people are being added to the planet every day, which is an unsustainable rate. Hence, it is need of hour we should aim for single-child families.

4. National Security issue

Over populated countries should treat population boom as an issue of national security. As you can see, similar to food insecurity and climate change, uncontrolled and rapid population growth can be a national security threat in a way that it results to instability.

5. Changing Social Norms

Some couple choose not to have children and we have to respect their decision. This way we will be able to help curb the problem of overpopulation.

6. Providing Tax Benefits or Concessions

Governments of various countries can come up with various regulations and policies related to tax exemption to help solve overpopulation. For example, they can waive certain parts of income tax or lower income tax rates for couples who have one or two children.



1. **Life expectancy:** average number of years a person is expected to live.
2. **Global warming:** unusual increase of earth's temperature due to the heat trapped in the atmosphere by green house gases.
3. **Arable land :** land under cultivation.
4. **Social Norms:** Pattern of behavior in a particular group, community, or culture, accepted as normal and to which an individual is accepted to conform.
5. **Overpopulation:** *population* exceeding the carrying capacity of its ecological niche.
6. **Worldometers:** show **estimated current numbers** based on statistics and projections from the most reputable official organization.
7. **Census:** an official count or survey, especially of a population.
8. **Gender equality:** It is the vision that men and women should be treated equally in social, economic and all other aspects of society, and to not be discriminated against on the basis of their gender.
9. **Sustainable development:** is a way for people to use resources without the resources running out.
10. **Population explosion:** a sudden, large increase in the size of a population.

Exercise

I. Choose the correct answer

1. _____ is the statistical study of human population. It includes the study of size, structure and distribution of population as well as changes in time and location in response to birth, migration, aging and death.

- a) Demography b) Geography
c) Anthropogeography d) Bio Geography



2. Which of the following are not densely populated areas?

- a) The Ganges valley, Brahmaputra valley, and Eastern Asia.
b) The Ganges valley, Brahmaputra and NE USA.
c) Sahara, Eastern Siberia and Patagonia region.
d) Brahmaputra valley, Hwang – Ho valley and North Western Europe

3. Pick out the option which consists of moderate density of population.

- i) Central part of the United States of America, Tropical Western Africa, Western blocks of Russia, Eastern Europe,
ii) Deccan Plateau of India, Central China, Southern portion of the Plateau of Mexico,
iii) North-Eastern Brazil and Central Chile, Tropical Western Africa, Western blocks of Russia, Eastern Europe,
iv) Amazon forest region of South America and Congo forest region of Africa, Arctic area of Canada and Greenland and the Polar regions.

- A) ii) and iii) only B) i) and ii) only
C) i), ii) and iii) only D) ii), iii) and iv) only

4. One of the following statements is untrue?

- A) The total arable land in the world is 13.3% and the nutritional density of the world is 325 per sq.km of land.
B) The total percentage of arable land is 48.83 in India and its nutritional density is 753 per sq.km of land.
C) Singapore has the highest nutritional density of population of 440,998 per sq.km of land in the world.
D) Singapore has the highest percentage of arable land in the world.

5. Match List - I to List - II and answer the following using the codes given.

List -I

List -II

- a) Niger i) Lowest literacy rate
b) Singapore ii) Highest sex ratio
c) Burkina faso iii) Highest fertility rate
d) Latvia iv) Highest nutritional density

	1	2	3	4
A)	(iii)	(iv)	(i)	(ii)
B)	(i)	(ii)	(iii)	(iv)
C)	(iv)	(iii)	(ii)	(i)
D)	(ii)	(iv)	(i)	(iii)

6. Consider the following statements and answer the right option from the given.

Statement: A large proportion of the world's population growth occurs in less developed countries.

Reason: The less developed countries have high birth rate and low death rate.

- Statement is right but reason is wrong.
- Statement is wrong but reason is right.
- Both statement and reason are right.
- Both statement and reason are wrong.

7. Consider the following statements carefully and answer the right option from the given below. Brain drain is concerned,

Statement –I. The receiving country is getting highly qualified labour.

Statement –II. Education and health costs are not paid back to the country of origin.

Statement –III. Receiving country is losing potential leaders and talent.

- Statement – I, II and III are right.
- Statement – I, II and III are wrong.
- Statement – I is right and statement –II and III are wrong.
- Statement – I and II are right and statement III is wrong.

8. One among the given is not a solution to overpopulation.

- Creating and Implementing National and Worldwide Multi-Media Overpopulation Awareness Campaigns
- Aiming for Single-Child Families.
- Treating it as a National Security issue
- Encouraging large family.

9. Odd one out.

- Mexico has the largest number of emigrants in the world while According to estimates from the UN 2015 report, in 2013, the United States had the largest number of immigrants of any country
- Qatar has the highest male to female ratio in the world while Latvia has highest female to male ratio in the world.
- Tripura has the highest literacy rate while Bihar has the lowest literacy rate in India.
- Rise in Unemployment, Crime Rate, and Violence is due to under population.

10. All of the following statements are correct except,

- India's population is 17.74% of the total world population.
- The population density in India is 350 per Km².
- 33.2 % of the population is urban.
- India ranks number 2 in the list of countries (and dependencies) by population.

II. Very short answer

- List the factors influencing the distribution of population
- Calculate the doubling time of world population if the growth rate is 1.09%.
- Mention the four reasons for low density of population.
- What is the sex ratio of India according to census 2011? Which three states/Union Territories have favourable sex ratio in India?

III. Short answer

- Given below is age structure of India and calculate the dependency ratio of India. Write an inference out of the result you get.

Age structure	Percentage
0-14 years	27.34%
15-64 years	66.42 %
65 years and over	6.24% (2017 estimate)

- Mention any three differences between expansive population pyramid and stationary population pyramid.
- Name six Indian states which account for about 70% of all illiterates in India.
- Differentiate push factor from pull factor as cause of migration.
- Define the physiological density of population.

IV. Answer the following in detail

- Read the diagram given below carefully and answer the following questions.

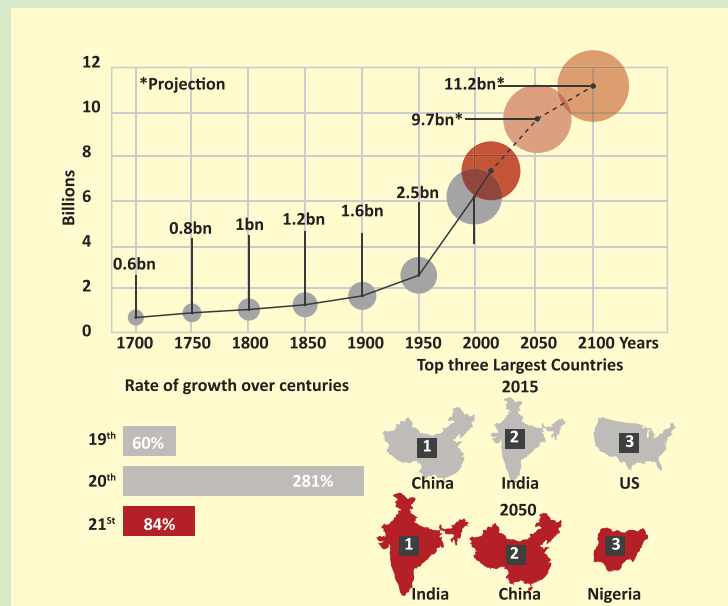

- What will be the world population by the year 2050 and 2100? How would it affect demand for fresh water?

- b) What would be the top three largest populated countries in 2050? Which country replaces the U.S as third largest populated country?
- c) How many people are added to the total population of the world every year? Which two countries have 37% of the world's population?
21. Write, in two sentences, each about how the following are the problems of over population.
- Depletion of natural resources
 - Accelerated loss of habitat
 - Amplified Climate Change and Global Warming
22. Read the population age pyramid of Bangladesh and answer the following carefully.

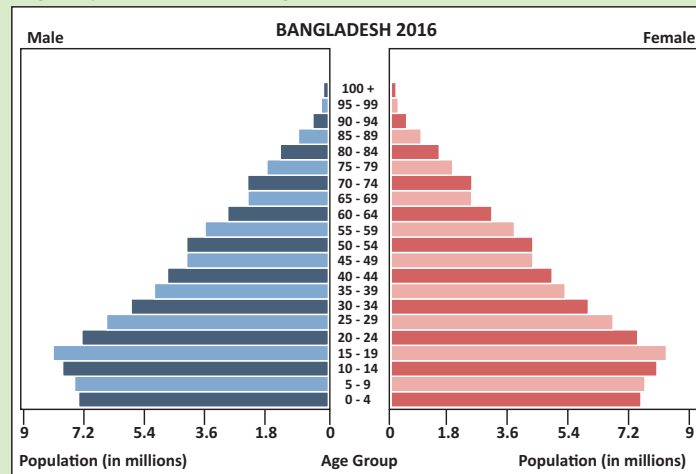

- What does wide the bottom of the population age pyramid indicate?
 - What type of population age pyramid is this?
 - Is the dependency ratio of Bangladesh positive or negative?
 - What type of economy does this population age pyramid belong to?
23. On the outline map of the world, show the areas of world population density and write a brief account of it.

V. Practice

24. Prepare two groups of students to debate on whether “overpopulation is a boon or bane”
25. Conduct an elocution on the topic “ Literacy rate is the dominant factor affecting the development of a nation at large”
26. Prepare three sets of each 25 multiple choice questions for each team from the lesson, conduct quiz.



References:

- Historical Estimates of World Population - US Census Bureau
- World Population Prospects: The 2017 Revision - United Nations Population Division
- The World at Six Billion, World Population, Year 0 to near stabilization [Pdf file] - United Nations Population Division
- Wikipedia
- Human geography , Majid Hussain



ICT CORNER

POPULATION

This activity enables the students to enrich themselves with POPULATION and increasing rate of the world population.

As it has many options it helps you explore many topics like what was the population when you were born etc.....



Steps

- Type the URL link given below in the browser or scan the QR code. A page opens with three options on the bar. Select the games options.
- It opens with five options on the side. You can select any one. Here the description is given for “Population and Me”.
- It opens to another page. Click the word “Let’s Go”
- When you select this it opens with the world map with three options. “POPULATION CHANGE”, “MY BIRTH COHORT” & “MY PLACE IN THE POPULATION”
- Each option gives it’s own information regarding population. You have to fill your age in the given place. My Birth Cohort gives you an idea on how many children were born on the same year in World as well as Asia.
- Like wise all the three options will give you various informations.



Step 1



Step 2

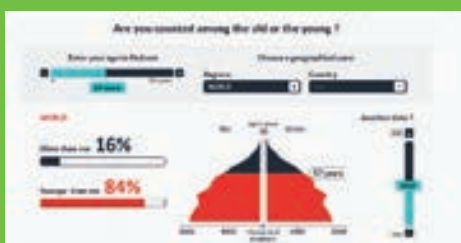

Step 3



Step 4

Website URL:

https://www.ined.fr/en/everything_about_population/population-games/tomorrow-population/

*Pictures are indicative only.



UNIT 2

Human Settlements



Unit Overview

- 2.1. Introduction
- 2.2. Origin and development of Settlement
- 2.3. Site and Situation
- 2.4. Pattern of Rural Settlement
- 2.5. Classification of Rural Settlement
- 2.6. Urban Settlement
- 2.7. The concentric zone theory
- 2.8. Urbanization of the World and India
- 2.9. Issues of Urbanization



Learning Objectives

- Identify various types of rural settlements.
- Differentiate site from situation.
- Understand various types of settlements in India.
- Establish the relationship between settlement types based on relief, climate and building materials.
- Analyse the distribution patterns of rural and urban settlements.
- Understand the models of urban land use



2.1. Introduction

Look at the front image of an oasis. It is an aerial view of the Huacachina oasis in Ica, Peru, 300 km south of Lima. The settlement is home to 96 residents, who live around the lake.

Now let us discuss on

1. Why the most oases are having hardly 100 residents or less?
2. How do people live in an oasis identify the direction at night?
3. What are the comforts and discomforts the people of Oasis experience?
4. Could you list some factors favouring settlements?

In simpler term we can define settlement as any form of human habitation which ranges from a single dwelling to a large city.

A human settlement is defined as a place inhabited more or less permanently. It includes building in which they live or use and the streets through which they travel. It also includes the temporary camps of the hunters and herders. It may consist of only a few dwelling units called hamlets or big cluster of building called urban cities.

2.2. Origin and development of Settlement

Most anthropologists believe that humans first appeared in the Great Rift Valley of East Africa thousands of years ago. From there, they spread to the Middle East, Asia, Europe, America and Oceania. Neolithic Revolution (Agricultural Revolution) occurred in Mesopotamia, people went from hunter-gatherers and nomads to domesticators. The population grew relatively quickly. The emergence of urban population occurred also in some areas. Agriculture became especially successful largely in the river valleys of Nile, Ganges and Yangtze kiang.



Harappa Settlement on the Indus river valley

These areas had fertile soil from annual flooding which led to abundant harvest. First cities arose in these areas and people were able to grow surplus food to feed a non-farming urban population thereby leading to specialization among the population. The priests, scribes, architects, farmers, soldiers, traders, blacksmiths, etc. were some other people ventured in these areas.

2.3. Site and Situation

Site

The Site of a settlement describes the physical nature of where it is located. Factors such as water supply, building materials, quality of soil, climate, shelter and defence were all considered when settlements were first established. For instance, the site of Sydney, in Australia, initially took advantage of the

excellent natural harbour and surrounding fertile farmland.

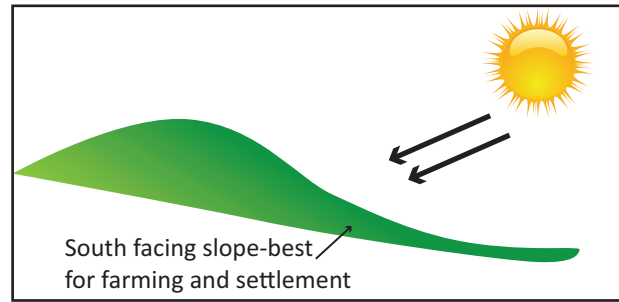

Settlement in the south facing slope of the Alps

Aspect and shelter are two of the most important factors that were considered when deciding where to locate a settlement. Aspect relates to the direction in which the land faces. In the Northern Hemisphere the best slopes to locate on are those that face south, as they will receive the most sunshine, and therefore be the best for agriculture. This can be seen clearly in many of the valleys of the Alps, where settlements have located on the south-facing slopes.

Shelter is also very important, particularly from the cold northerly winds and prevailing south westerly winds in the UK. A good example of settlements being sheltered by their natural surroundings are the many spring-line settlements found along the base of the chalk escarpments of the North and South Downs. These settlements would also have benefited from the good water source and fertile farmland nearby.

1. Water supply

Water supply is probably the single most important factor in deciding where a settlement might be located. Not only do rivers provide a source of clean drinking water, they also provide a food source through fishing, and a transport route. Most of the world's largest cities are located on rivers, especially the point at which they reach the sea, as this was often the first point that explorers landed.

2. Dry point sites

A dry point site is one that is slightly raised from the surrounding area, meaning that it is less likely to flood. Ely in Cambridgeshire, England, is a good example of dry point site.

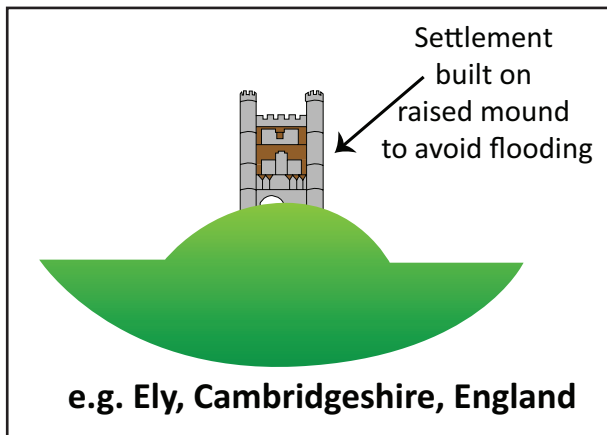

3. Wet point sites

Wet point site refers to any site that has access to water, usually through being beside a river. Towns would either grow up along the river or clustered near the point at which the river enters the sea. Examples of wet point sites include the towns and villages of the

Welsh valleys, which tend to extend along the flat valley floor, rather than up the steep valley sides. Spring line settlements in the North and South Downs, England are also good examples of wet point sites.

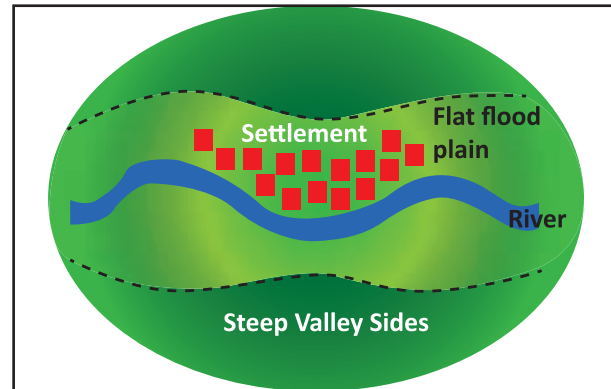

4. Defence

In medieval times, defence was one of the most important factors influencing the site of a settlement. The relief of the land often proved to be the best form of defence. Edinburgh castle sits on the top of a glacial crag, in an almost perfect position to defend itself, with very little chance for the attackers. In Italy, there are many walled hill-top villages, whilst the Maoris in New Zealand built their settlements (called Pa's) on the top of steep hills to prevent being attacked. In India, Ichhapur Defence Estate is a census town in Barrackpore, West Bengal.

The other common natural feature used for defence is water, and in particular rivers. Both Shrewsbury and Durham are very good examples of where a meander of the river has formed an area of land bounded by water on three sides. This provided both cities with excellent defence, as they only had a thin neck of land to defend.

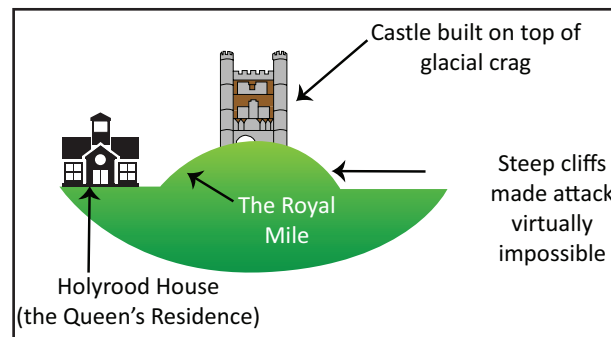



5. Resources

The idea of resources covers a huge number of different things. For early settlers the most important resources were fuel, building materials and food. Settlements grew in areas where wood was plentiful, stone easily accessible and good soil allowed agriculture to be developed.

Since in early days of settlement many different resources have become the focal points for the growth of urban areas. Some of the settlements based on the resources are listed below:

6. Mining

The coal mines of South Wales, Tin mines of Cornwall and large mining projects at Carajas in Northern Brazil, have all encouraged the rapid growth of settlements aimed at housing the workers and providing them with all that they require.

7. Precious metals

Settlements in South Africa have grown after the discovery of large deposits of precious metals such as gold. The most famous settlement grew due to finding gold is San Francisco, after the gold rush to California in 1849.

8. Route centres

Route centres are often called Nodal Points. Nodal Points are formed by the meeting of two valleys, but settlement nowadays will grow

where two main roads meet. In the UK, York is a good example of a route centre. Birmingham also enjoys a very good location, where many routes join up, and this is one of the reasons for its growth to become one of the largest cities in the UK.

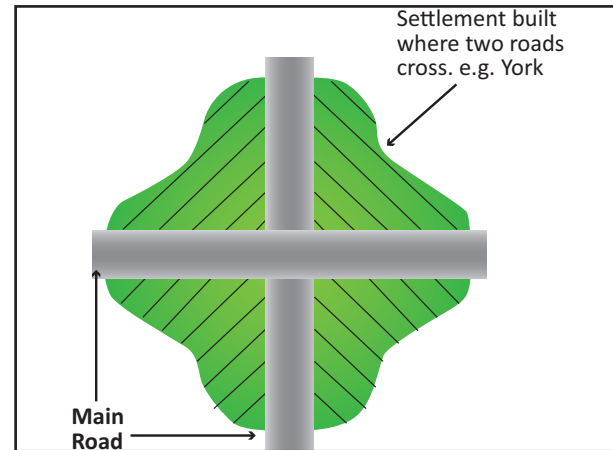

9. Bridging points

Just as water is very important for drinking, fishing, irrigation and navigation, so the ability to cross the rivers is also very important.

Many towns and cities have built up at points where it was the easiest to cross a large river. Exeter is one such example, crossing the river Exe in England.

However one of the best examples is Paris in France. The original town was based on the tiny Ile de la Cite, which is an island in the middle of the River Seine. This island meant they could build two small bridges across the river rather than one large one.

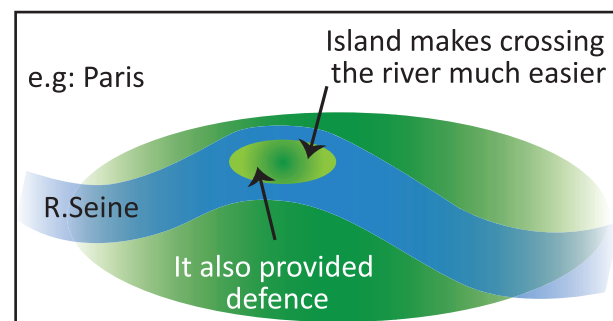

Nowadays the island has been engulfed by the huge city that Paris has become, however it does still have many bridges going to it and is



the point where the huge Notre Dame Cathedral is built.

10. The confluence of two rivers

Just as two valleys, or roads, make a nodal point for settlement growth, so do two rivers joining. One such example is found in Khartoum in Sudan, where the Blue and the White Nile meet. In India, Allahabad is located at the confluence of River Ganga and Yamuna and Bhavani (Tamil Nadu) is at the confluence of River Cauvery and Bhavani.

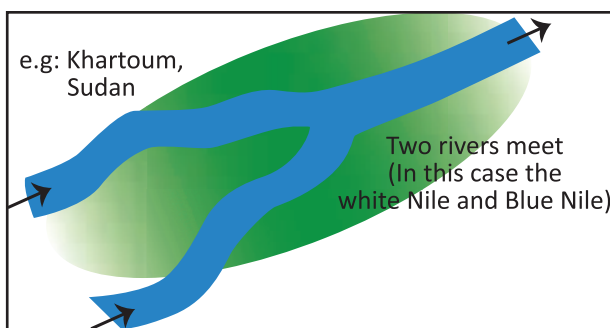

Situation

The situation of a settlement is the description of the settlement in relation to the other settlements and physical features around it. The situation of a settlement is the most important in determining whether it grows to become a large city or stays as a small town or village.

In the UK, Birmingham is an example of a city with excellent situation. It is located central to the country, with excellent links by road to the North and South to London.



As cities begin to fulfill different functions their importance can increase or decrease. Their situation plays an important part in deciding which of these functions will occur.

It refers to the location of the actual settlement. The initial choice of a site for a settlement depends on its meeting certain daily needs such as water supply, availability of potential farmland, building materials and fuels etc.

Settlements can broadly be divided into two types – rural and urban. Let us know some differences between rural and urban areas in general.

- i. The major difference between rural and urban areas is the function. Rural areas have predominantly primary activities such as agriculture, whereas urban areas have domination of secondary and tertiary activities such as manufacturing industries and service sectors.
- ii. Generally the rural areas have low density of population than urban areas.
- iii. Urban settlements are defined by their advanced civic amenities, opportunities for education, and facilities for transport, business and social interaction and overall better standard of living whereas rural areas lack of such amenities.
- iv. Rural areas do not have pollution or traffic problems that beset regular urban areas.

- v. In the rural society there was very little scope for occupational mobility. In cities there are many occupations, so occupational mobility is frequent
- vi. Rural people are less mobile and therefore the social relations among them are intimate. In urban areas, the way of life is complex and fast, hence, the social relations are formal.

2.4. Pattern of Rural Settlement

On the basis of forms or shapes of the settlements, rural settlements are classified as Linear, Rectangular, Circular, Star like, T-shaped village, Y-shaped village, Compact, Disperse, Planned, etc.

The settlement in which houses are constructed along a road, railway line, river, canal edge of a valley, or along a levee is known as **Linear Pattern**.



The settlements constructed in a rectangular shape are known as **Rectangular Pattern**. Such kind of settlements is found in plain areas and in wide inter-montane valley.



The settlements constructed in a circular shape are known as **Circular Pattern**. Such kind of settlement is found around lakes, tanks, or a planned village.

The settlements constructed in a star shape are known as Star like Pattern. Such kind of settlement is found around the points where several roads cross each other (making star shape).

The settlements in which houses are constructed at the tri-junctions of the roads are known as **T-shaped Pattern**. Such kind of settlement is found along the road, which meets with another road at the dead end (the straight going road ends) and bifurcates left and right (T-Shape).

The settlement, in which houses are constructed along the straight road, is known as **Y-Shape pattern**. It is further bifurcated into two roads (similar to Y shape),

2.5. Classification of Rural Settlement

Based on shape, the settlements are classified as

1. Compact or Nucleated Settlements

In the nucleated settlements, the houses are built very close to each other. Normally, fertile plain regions have such compact or nucleated settlements.

2. Dispersed Settlements

In such kind of settlements, houses are spaced far apart and often interspersed with fields, however, their market and some other activities are centralized where they participate together.



2.6. Urban settlements

The census of India, 1991 defines urban settlements as “All places which have municipality, corporation, cantonment board or notified town area committee and have a minimum population of 5000 persons, at least 75 per cent of male workers are engaged in non-agricultural pursuits and a density of population of at least 400 persons per square kilometers are urban settlements.

Evolution of Urban Settlements

The first urban settlement to reach a population of one million was the city of London by around A.D. 1810. By 1982 approximately 175 cities in the world had crossed the one million population mark. Presently 48 per cent of the world’s population lives in urban settlements compared to only 3 per cent in the year 1800.

Stages of Urban Settlements

Depending on the size and the services available and functions rendered, urban centers are designated as town, city, million city, conurbation, Megalopolis.

Town (Population more than 5000 people)

The concept of ‘town’ can best be understood with reference to ‘village’. Population size is not the only criterion. Functional contrasts between towns and villages may not always be clear cut, but specific functions such as, manufacturing, retail and wholesale trade, and professional services exist in towns.



Kraal is a group of houses surrounding an enclosure for livestock, or the social unit that inhabits these structures. The term has been more broadly used to describe the way of life associated with the kraal that is found among some African, especially South African, peoples. Kraal consists of a number of huts arranged in a circle around a cattle corral. Polygyny is common, and each wife has her own hut within the kraal. The head of the kraal may have custody of the property attached to the houses of his several wives.

City (Population more than 100,000)

A city may be regarded as a leading town. Cities are much larger than towns and have a greater number of economic functions. They tend to have transport terminals, major financial institutions and regional administrative offices. When the population crosses the one million mark it is designated as a million city.

Conurbation (Population of 2 or more cities combined)

The term conurbation was coined by Patrick Geddes in 1915 and applied to a large area of urban development that resulted from the merging of originally separated towns or cities. Greater London, Manchester, Chicago and Tokyo are examples. In India, Hyderabad and Cochin are the examples of conurbation cities.

Megalopolis (Population more than 10 million)

This Greek word “Megalopolis” meaning “great city”, was popularized by Jean Gottman (1957) and signifies ‘super- metropolitan’ region extending, as union of conurbations. The urban landscape which stretches from Boston in the north to south of Washington in the U.S.A is the best known example of a megalopolis.

Million City (Population more than 1 million)

A city with million or more people is termed as the million city. The number of million cities in the world has been increasing as never before. London reached the million marks in 1800, followed by Paris in 1850, New York in 1860, and by 1950 there were around 80 such cities. The rate of increase in the number of million cities has been three-fold in every three decades – around 160 in 1975 to around 438 in 2005.



Million City

CASE STUDY

The fastest growing city of Tamil Nadu!



Tiruppur is located at 11.1075°N and 77.3398°E on the banks of the Noyyal River. It has an average elevation of 295 metres (967 feet) and covers an area of 159.6 km².

Tiruppur was an agricultural town with irrigated farms and the farmers became small

owners of various textile related units during the 1970s. The boom in the textile industry led to an interwoven network of the small scale units leading to growth of the city into a major textile hub.

The recent revelation of the study conducted by Oxford Economics marked several Indian cities in top ten categories of fastest-growing cities of the world.

Tiruppur, bags the sixth fastest growing city in India followed by Tiruchirappalli and Chennai.

HOT

Why did London become the first million city of the world?

Definition of Town

In 2001, places were designated as urban or towns on the following principles.

- (a) All places with Municipality, Corporation, Cantonment Board, Sanitary Board, Notified Area Committee etc.
- (b) All other places which satisfy the following criteria.
 - i) A minimum population of 5,000.
 - ii) At least 75 per cent of the male working population being engaged in non-agricultural (and allied) activity.
 - iii) A density of population of at least 400 persons per square kilometer (or one thousand persons per square mile).

The Urban Agglomeration

As per census 2001, it was decided that the core town or at least one of the constituent towns of an urban agglomeration should necessarily be a statutory town and the total population

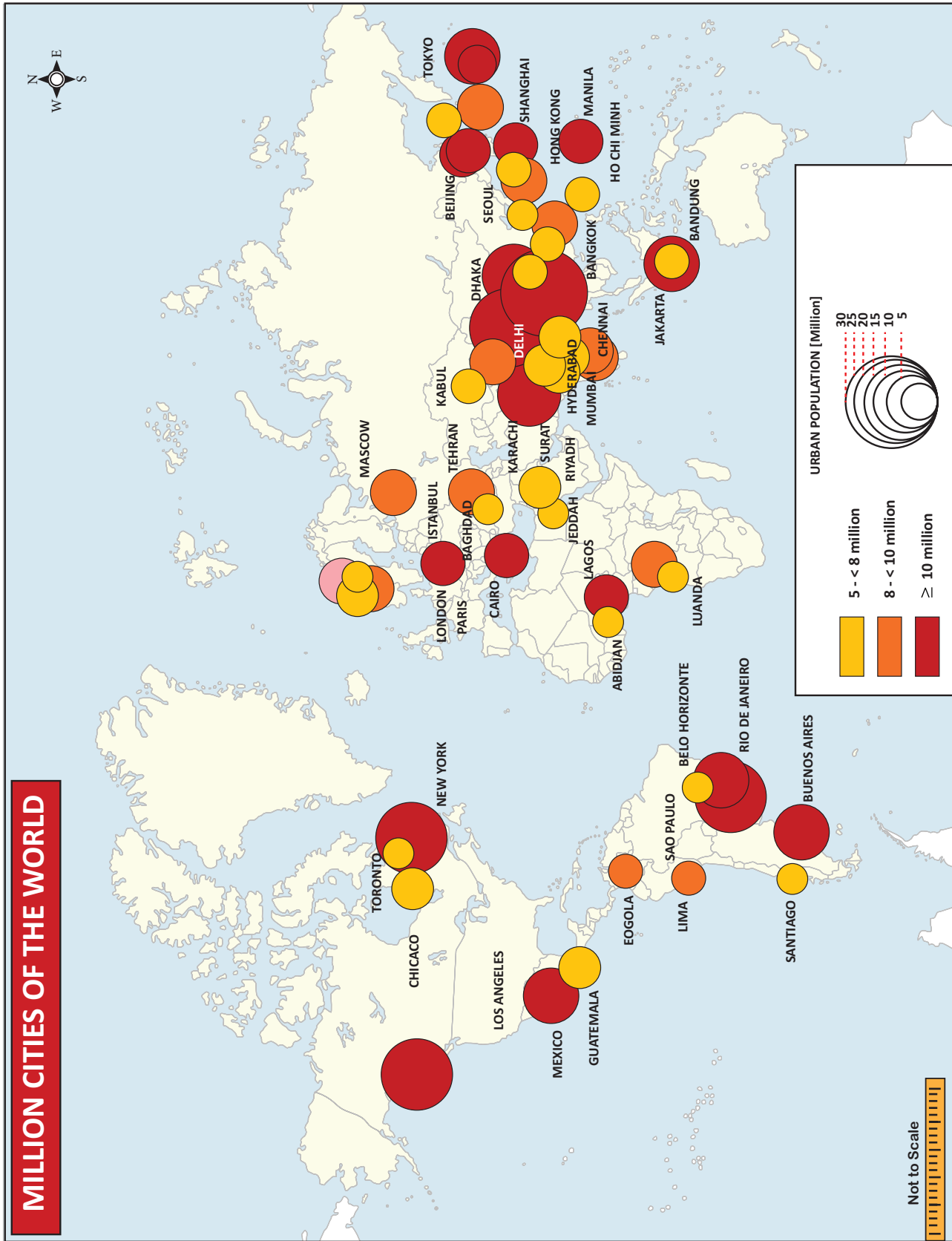

of all the constituents should not be less than 20,000 (as per 1991 census).

Urban agglomeration is a continuous urban spread constituting a town and its adjoining urban outgrowths (OGs), or two or more physical contiguous towns together and any adjoining urban outgrowths of such towns. Examples of Outgrowth are railway colonies, university campuses, port area, military camps etc. that may have come up near a statutory town or city but within the revenue limits of a village or villages contiguous to the town or city. With these two basic criteria having been met, the following are the possible different situations in which urban agglomerations could be constituted.

- i) A city or town with one or more contiguous outgrowths.
- ii) Two or more adjoining towns with or without their outgrowths.
- iii) A city and one or more adjoining towns with their outgrowths all of which form a continuous spread.

Standard urban area

A new concept that had been developed for the 1971 Census for the tabulation of certain urban data was the Standard Urban Area.

The essential of a Standard Urban Area are:

- (i) It should have a core town of a minimum population size of 50,000.
- (ii) The contiguous areas made up of other urban as well as rural administrative units should have close mutual socio-economic links with the core town and
- (iii) The probabilities are that this entire area will get fully urbanized in a period of two to three decades.

The idea is that it should be possible to provide comparable data for a definite area of urbanization continuously for three decades which would give a meaningful picture. This

replaced the concepts of Town Group that was in vogue at the 1961 Census. The town groups were made up of independent urban units not necessarily contiguous to one another but were to some extent inter-dependent. The data for such town groups became incomparable from census to census as the boundaries of the towns themselves changed and the intermediate areas were left out of account; this concept came for criticism at one of the symposium of the International Geographic Union in 1968 and the concept of Standard Urban Area came to be developed for adoption at the 1971 Census. If data for this Standard Area were to be made available in the next two or three successive censuses, it is likely to yield much more meaningful picture to study urbanisation around large urban nuclei.



Ecumenopolis (Ecumeno means world; polis means city) is a single city encompassing the whole world that is held to be a possibility of the future.

Basis for classification of urban settlements

The definition of urban areas varies from one country to another. Some of the common bases of classification are size of population, occupational structure and Administrative setup.

Population size

In India the size of population, density of 400 persons per sq km and share of non-agricultural workers are taken into consideration.

Occupational structure

In India if more than 50 per cent of its economically productive population is engaged in non-agricultural pursuits.

Administration Setup

For example, in India, a settlement of any size is classified as urban, if it has a municipality, Cantonment Board or Notified Area Council.

Classification of Urban Settlement

Depending upon the functionality of the urban settlement, towns are classified as Administrative Towns, Commercial Towns, Cultural Towns, Recreational Towns, and Industrial Towns.

The settlements that established for the administrative purpose or having largely administrative function are known as **administrative towns**. For example, Washington D.C., New Delhi, Canberra, Paris, Beijing, Addis Ababa, and London etc.

The settlements that facilitate commercial opportunities are known as **trading and commercial towns**. For example, Agra, Lahore, Baghdad as an important transport node; Manchester and St Louis in land centers; Winnipeg and Kansas City as agricultural market towns; Frankfurt and Amsterdam as banking and financial centers; etc.



Recreational town, Volendum, Netherlands and Industrial town

The settlements established because of religious adherence are known as **cultural or**

religious towns. For example, Jerusalem, Mecca, Jagannath, Puri, Madurai and Varanasi, etc.

The settlements established for the recreational purpose are known as **recreational towns**. For example, Miami (U.S.A), Panaji (India), etc.

The settlements established because of industrial development are known as **industrial towns**. For example, Pittsburgh (U.S.A), Jamshedpur (India), etc.

2.7 The concentric zone theory

This theory was given by Ernest Burgess in 1925. He envisaged that the development of a city outwards from a centre in concentric zones in a ripple-like fashion. He made the following assumptions:

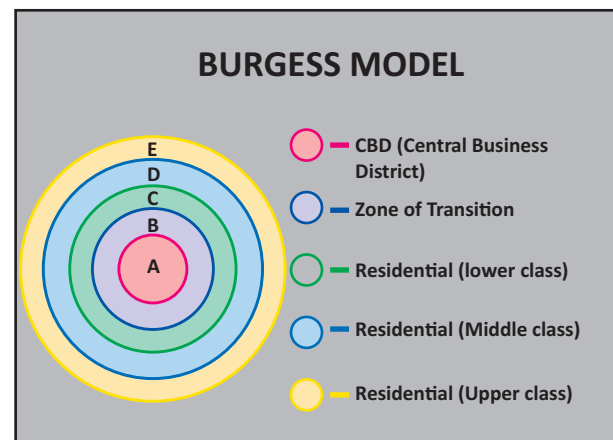

A. The city grows outwards in the form of five concentric zones or rings as long as there are no physical barriers, such as rivers or hills to distort the pattern.

B. The city has a single centre.

C. Growth is accomplished by a simple extension of each zone outwards into the next zone.

The characteristic features of each of the five zones can be described as follows.

Zone A: The central business district (C.B.D)

It is the heart of the urban community where the commercial, social and civic activities are concentrated. The heart of the C.B.D. or the downtown core has office buildings,

departmental stores, theatres, hotels, banks and civic government buildings, while outside this core are warehouses and light industry.

Zone B: The transition zone next to the C.B.D

It is the transition zone where the central business activities and factories mix and invade an area of aging residential dwellings. This is also the zone of residential decay where the new migrants come and live because the rents are low and transportation costs to the workplace are minimal. Thus, these are the sites of urban slums.

Zone C: The zone of independent working men's home

This zone is inhabited by the blue-collar workers who are generally the second generation migrants. These people have the capacity to own their individual houses away from the C.B.D., but still live within easy access of their workplace. Here, the family groups are more stable and crime rates are lower.

Zone D: The zone of better residence

The next concentric zone has middle and upper class residences which are approximately 15 to 20 minutes by public transport from zone 1.

Zone E: The commuter zone

This outer zone encircles the city and lies beyond the continuous built-up areas. Much of this zone is still an open space and is often located beyond the city limits. Here, small villages, surrounded by open country, gradually become suburbs. Since people in this zone work in the C.B.D., the commuter zone is located within one hour's travelling time from the centre of the city.

Burgess stressed that the outward growth of the city implies that each zone is not static. Business activities expand into the transition zone which forces low income groups to move outwards. This group, then, displaces the middle class and the wealthy that, in turn, are forced to move outwards.

2.8. Urbanization of the World and India

Urbanisation refers to the population shift from rural to urban residency, the gradual increase in the proportion of people living in urban areas and the ways in which each society adapts to this change.

It is predominantly the process by which towns and cities are formed and become larger as more people begin living and working in central areas. Although the two concepts are sometimes used interchangeably, urbanization should be distinguished from urban growth. Urbanization is "the proportion of the total national population living in areas classed as urban," while urban growth refers to "the absolute number of people living in areas classed as urban". The United Nations projected that half of the world's population would live in urban areas at the end of 2008. It is predicted that by 2050 about 64% of the developing world and 86% of the developed world will be urbanized.

That is equivalent to approximately 3 billion urbanites by 2050, much of which will occur in Africa and Asia. Notably, the United Nations has also recently projected that nearly all global population growth from 2017 to 2030 will be absorbed by cities, about 1.1 billion new urbanites over the next 13 years.

Urbanisation in India began to accelerate after independence, due to the country's adoption of a mixed economy, which gave rise to the development of the private sector. Urbanisation is taking place at a faster rate in India. Population residing in urban areas in India, according to 1901 census, was 11.4%. This count increased to 28.53% according to 2001 census, and crossing 30% as per 2011 census, standing at 31.16%. According to a survey by UN State of the World Population report in 2007, by 2030, 40.76% of country's population is expected to reside in urban areas. As per World Bank, India, along

with China, Indonesia, Nigeria, and the United States, will lead the world's urban population surge by 2050.

Mumbai saw large scale rural-urban migration in the 20th century. Mumbai, in 2018, accommodates 22.1 million people, and is the largest metropolis by population in India, followed by Delhi with 18.6 million inhabitants. Witnessing the fastest rate of urbanisation in the world, as per 2011 census, Delhi's population rises by 4.1%, Mumbai's by 3.1% and Kolkata's by 2% as per 2011 census compared to 2001 census.



Kathipara flyover, Chennai.

Urban fringe

Urban fringe is an area of transition between well recognized urban land uses and the area devoted to agriculture. It is an area where there is a mixture of rural and urban land uses and where a process of change from rural to urban land use is taking place. The urban fringe has the appearances of a proper city with residential and commercial centers, but it often lacks proper city services such as piped water supply, sewage and garbage disposal facilities. It may include the municipal towns and fully urbanized revenue villages contiguous to the main city.

Urban sprawl or suburban sprawl

Urban sprawl or suburban sprawl describes the expansion of human populations away from central urban areas into low-density, monofunctional and usually car-dependent communities, in a process called

suburbanization. In addition to describing a particular form of urbanization, the term also relates to the social and environmental consequences associated with this development. In Continental Europe the term "peri-urbanisation" is often used to denote similar dynamics and phenomena, although the term urban sprawl is currently being used by the European Environment Agency. There is widespread disagreement about what constitutes sprawl and how to quantify it. For example, some commentators measure sprawl only with the average number of residential units per acre in a given area. But others associate it with decentralization (spread of population without a well-defined centre), discontinuity (leap frog development), segregation of uses, and so forth.

Causes of Urban Sprawl

Urban sprawl can be caused by many factors. They are:

Lower Land Rates: Lower cost land and houses in the outer suburbs of the cities, because the centers of urban development have really made people want to stop settling in these areas and want to venture further out.

Rise in Standard of Living: There are also increases in standards of living and average family incomes, which means that people have the ability to pay more to travel and commute longer distances to work and back home.

Lack of Urban Planning: People love to find areas that are less trafficked and more calm, which leads them to sprawl out to other sections of the town. Unprecedented development, cutting of trees, loss of green cover, long traffic jams and poor infrastructure force the people to move out to new areas.

Lower House Tax Rates: Cities will usually have high property taxes, and you can usually avoid these taxes by living in the outer suburbs because the taxes are usually lower than they are in other situations.

Rise in Population Growth: Another factor that contributes towards urban sprawl is rise in population growth. As number of people in a city grows beyond capacity, the local communities continue to spread farther and farther from city centers.

Consumer Preferences: People in high income groups have stronger preferences toward larger homes, more bedrooms, bigger balconies and bigger lawns. This also causes urban sprawl as this option is not available in crowded cities. People generally look out for low-density residential areas where they can get home according to their preference.



Smart city of the future

2.9. Problems of Urbanization

India has the second largest urban population in the world only after China. India's urban population (about 28% of the total population) is almost equal to the total population of USA. The rate of urban growth is on the upswing. People in large number are arriving in the mega and metropolitan cities, swelling urban India by more than five per cent annually. This stupendous growth of population is the cause of numerous socio-economic and environmental problems. Some of the important problems of urban India have been briefly presented below:

1. Problem of space and scarcity of residential accommodation

The growing population demands more space which is not easily available because of physical and geographical constraints. The scarcity of space leads to high price of land and high rents for offices and residential accommodations. Since people cannot afford high rents, it is the main cause of unwanted growth of slums

According to one estimate, there is an annual shortage of about two million houses in Indian cities. This has forced low income group people to live in slums or occupy footpaths and road pavements. The number of such slums and pavement dwellers is rising in the metropolitan cities of India.

2. Inadequacy of Social Amenities

In most of the cities of India, there is growth and not urbanisation. In fact, the number of people is increasing in the cities while the infrastructural facilities and civic amenities are quite inadequate. With greater concentration of people in urban places, the social amenities like housing, electricity, drinking water, transport, sanitation, sewage disposal, educational institutions, hospitals, parks, playgrounds, and recreational facilities are quite under great stress.

3. Unemployment

Unemployment is the state of being involuntarily out of work. In India, the rate of urban unemployment which is more than 3 per cent annually is increasing progressively. According to one estimate, about 25 per cent of the workers in the urban centres are unemployed. The high rate of unemployment and under-employment often leads to high rate of crime.

4. Problem of Transport

Transport bottlenecks and traffic congestion are the major problems of most of the Indian cities. The larger a town grows the more important its functions become. The

workers and commuters need more transport facilities. Unfortunately, the roads in most of the cities, especially in the old towns (down-towns) are narrow which cannot cope with the growing pressure of passengers, travelers, and commuters. The number of private vehicles is rising steeply. It leads to traffic congestion, delays, irritation, and tension. If the number of vehicles is allowed to increase at the present rate without widening and upgrading the roads, the whole transport system of the major cities may collapse.

5. The Energy Crisis

The shortage of energy reduces the industrial production of goods and their distribution. In fact, energy depends on the industrial growth, efficiency of the transport and human comfort. The peak power demand in the metropolises, million and class one cities is increasing day by day and power situation is not geared to meet it.

6. Inadequacy of Water Supply

Water is the first and foremost necessity of human life. In fact, water is life, and man cannot survive without it. The average per capita consumption of water in Kolkata is 250 litres, in Mumbai 175 litres and only 80 litres in Delhi as against 1200 litres in Los Angeles and 1100 litres in Chicago. The acute scarcity of water in the urban places of India may be appreciated from the fact that in Chennai, Hyderabad, Jaipur, Jodhpur, Nagpur, Shimla, Solan, Surat, Udaipur, Vadodara, etc., only one to two hours of water supply in a day is permitted. The National

Capital (New Delhi) also regulates water supply to only about four hours a day.

7. Environmental Pollution

Environmental pollution is the other serious problem of all the million and mega-cities. It is not only air-pollution caused by smoke emitted from vehicles, factories and houses; water and noise pollutions are equally serious. The scarcity of dumping grounds makes the rural-urban fringe unhygienic and less conducive for human health. The problem of garbage disposal (hazardous plastics, metal and package) is thus quite serious in most of the Indian cities and urban places. Unfortunately, most of the garbage is dumped into the rivers or along their banks. The cities like Mumbai, Kolkata, and Chennai continue to discharge a major part of their garbage into the sea.

8. Increase in Crimes

Increasing urban crimes are disturbing the peace of modern cities. According to sociologists, unemployment is the main cause of crimes in urban areas. The unemployed youths indulge in crime like abduction, extortion, kidnapping, murder, pick-pocketing, rape, robbery, snatching, and theft. The slums are especially infested with unemployed criminals who, in due course of time, become habitual offenders. Material culture, growing consumerism, selfishness, stiff competition, lavishness, increasing socio-economic disparities, rising unemployment and loneliness are some of the main reasons of this menace.



1. **Oasis:** a green spot in the desert.
2. **Urban sprawl:** the spread of city buildings and houses into an area that used to be countryside.
3. **Agglomeration:** An extended town area consisting of the built-up area of a central place and any suburbs linked by continuous urban area.

4. **Crime:** an action or omission which constitutes an offence and is punishable by law.
5. **Energy crisis:** any significant bottleneck in the supply of energy resources to an economy.
6. **Smart city:** an urban area that uses different types of electronic data collection sensors to supply information which is used to manage assets and resources efficiently.
7. **Unemployment:** The state of being unemployed.
8. **Site:** a point or an area on the Earth's surface or elsewhere.
9. **Anthropologist:** a person engaged in the practice of anthropology.
10. **Conurbation:** Area of urban development resulted from merging of two cities.



Exercise

I. Choose the correct answer.

1. Most anthropologists believe that hundreds of thousands of years ago humans first appeared in
 - a) The Euphrates and Tigris valley
 - b) The Indus valley of Asia
 - c) The Great Rift Valley in East Africa
 - d) The Nile valley of Africa
2. The first urban settlement to reach a population of one million (Million city) is
 - a) London
 - b) Paris
 - c) New York
 - d) Tokyo
3. It is predicted that by 2050 about the developing world and the developed world will be urbanized to
 - a) 74% & 76% respectively
 - b) 64% & 86% respectively
 - c) 54% & 96% respectively
 - d) 44% & 66% respectively
4. As per 2011 census, which one of the following is correct?
 - a) Delhi's population rose by 4.1%,
 - b) Mumbai's by 5.1%
 - c) Kolkata's by 4%
 - d) Chennai's by 5%
5. One of the following statements is untrue regarding the concentric zone theory model.

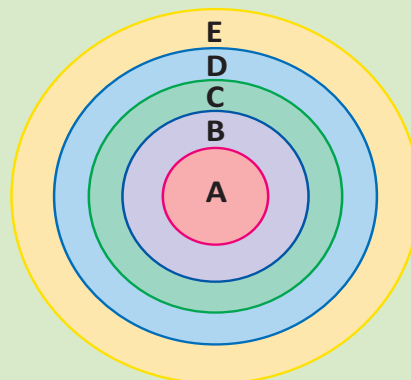

- a) This model was given by Ernest Burgess in 1925.
- b) Letter E in the model indicates medium – class Residential

- c) He envisaged that the development of a city outwards from a centre in concentric zones in a ripple like fashion.
- d) Letter B in the model indicates Zone in Transition
6. Consider the statements given below and choose the right option from the given.
- Statement I:** Urban fringe is an area of transition between well recognized urban land uses and the area devoted to agriculture.
- Statement II:** Urban sprawl or suburban sprawl describes the expansion of human populations away from central urban areas into low-density, monofunctional and usually car-dependent communities, in a process called suburbanization.
- a) Statement - I is right. Statement - II is wrong.
- b) Statement - I is wrong. Statement - II is right.
- c) Statement - I and Statement - II are right.
- d) Statement - I and Statement - II are wrong.
7. Match list – I to list – II and answer using the codes given.
- | List -I | | List – II | |
|------------------------|--------------------------------|---------------|--|
| a) Administrative town | | i) Pittsburgh | |
| b) Recreational Town | | ii) Beijing | |
| c) Religious Town | | iii) Miami | |
| d) Industrial Town | | iv) Jerusalem | |
| | a) b) c) d) | | |
| a) | i) ii) iii) iv) | | |
| b) | iii) iv) i) ii) | | |
| c) | iv) iii) ii) i) | | |
| d) | ii) iii) iv) i) | | |
8. Which one of the following statements is false about urbanization?
- a) The high rate of unemployment and under-employment often leads to high rate of crime.
- b) With greater concentration of people in urban places, the social amenities are quite under great stress.
- c) The scarcity of dumping grounds makes the rural-urban fringe organically rich and more conducive for human health.
- d) The scarcity of space leads to high price of land and high rents for offices and residential accommodations.
9. Which of the following is/are an essential characteristic/s of a Standard Urban Area?
- (i) It should have a core town of a minimum population size of 50,000,
- (ii) The contiguous areas made up of other urban as well as rural administrative units should have close mutual socio- economic links with the core town and
- (iii) The probabilities are that this entire area will get fully urbanized in a period of two to three decades.

- (i), (ii) and (iii) (i) and (iii) only
 (ii) and (iii) only (iii) only

10. One of the following statements is incorrect about the dispersed settlement.
- Houses are spaced far apart.
 - Often interspersed with fields.
 - Their market and some other activities are centralized where they participate together.
 - Found in the fertile river valley.

II. Very brief answer

- Differentiate site from situation.
- List the types of rural settlement.
- Who defined the term conurbation? Give an example of conurbation.
- Mention any two differences between CBD and commuter zone.
- Who proposed the Concentric Zone theory and what are the assumptions made by him?

III. Brief answer

- Differentiate nucleated settlement from dispersed settlement.
- Write a note on Megalopolis.
- Mention any three characteristics of a standard urban area.
- Write any three causes of Urban sprawl.
- Define million city and give an example.

IV. Detailed answer

- How is rural settlement different from urban settlement?
- Describe the pattern of rural settlement.
- Explain the problems of urbanization.

Practice

- Discuss in group the causes and effects of social issues due to urbanization.
- Debate on the topic: life is better in village or city.



Reference

- Human Geography, Majid Husain.
- Introduction to Geography, Getis Getis Fellmann.
- Geography of Settlements, R.Y.Singh.



Web reference

http://censusindia.gov.in/Data_Products/Library/Indian_perceptive_link/Census_Terms_link/censusterms.html.

Report of 'Manual on Vital Statistics (Govt. of India).



ICT CORNER

Human Settlements

This activity gives a very good information on settlement and The reason for the place they selected to settle.



Steps

- Type the URL link given below in the browser or scan the QR code. A page opens with some options on the left side. Select the required one.
- It gives you great information on the selected topics with pictures.
- Explore all options and gain good ideas on settlement



Step 1



Step 2



Step 3



Step 4

Website URL:

http://www.projects.yrdsb.edu.on.ca/pioneer/home_eng.htm

*Pictures are indicative only.



UNIT 3

Resources



Unit Overview

- 3.1 Introduction
- 3.2 Classification of Resources
- 3.3 Mineral resources
- 3.4 The world distribution of minerals
- 3.5 Energy Resources
- 3.6 Conservation of Resources

3.1 Introduction

Have you heard about **Voyager 1** launched in 1977 still is travelling at the speed of **62140 km/hour or 17 km/sec.?** Do you know what fuel is used in it? It is **hydrazine**. What, do you think, would be the future fuel? It is certainly going to be **hydrogen**. Think about how hydrogen stands as an important future fuel.

A resource is a naturally occurring exploitable material that a society perceives to be useful to its economic and material wellbeing. Willing, healthy and skilled workers also constitute a valuable resource, but without access to materials such as fertile soil or petroleum, human resources are limited in their effectiveness.

Resources are the basis of the economic development of any nation. Different countries are at different levels of economic development



Learning Objectives

- Understand the classification of resources.
- Estimate the world reserves of the resources.
- Reason out why there is an uneven distribution of resources.
- Describe the methods of conserving the resources.



primarily because of the variation in the availability of natural resources. The US and west European countries are economically prosperous because they possess vast natural and human resources and technology. On the other hand, in most parts of Africa and Asia, though they are naturally rich in resources, due to their lack of knowledge, the resources are unutilised and they are not used in the service of man.

3.2 Classification of Resources

Resources are classified on various bases. Based on the continual availability, resources are classified in to **renewable** and **non renewable resources**.

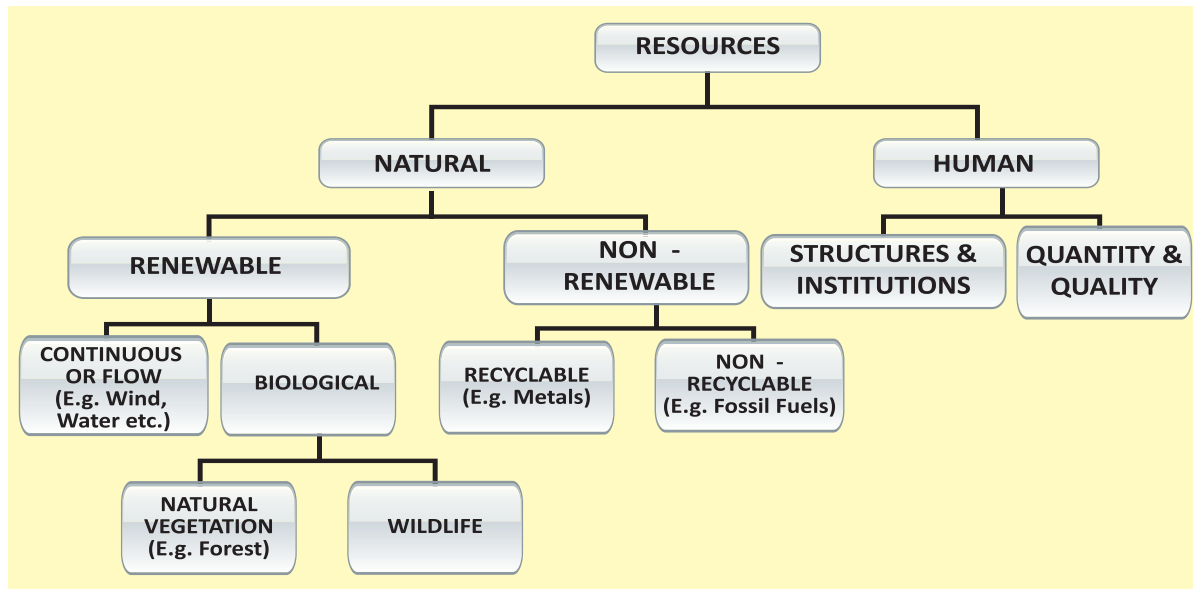

The resources which can always be used again and again are known as **renewable resources**. It means these resources have natural regeneration and are inexhaustible. Air, water, solar energy etc are examples of renewable resources. **Non renewable resources** are available in finite quantities and cannot be obtained once if they are utilized. If these resources are used in large scale, they will get exhausted soon and as such these resources are called as **exhaustible resources**. Coal, oil and minerals are examples of this type.

On the basis of origin, the resources are classified in to **biotic** and **abiotic resources**. When a resource is originated from living organism, the resource is known as **biotic resource**. Coal, mineral oil and forests are examples of biotic resources. **Abiotic resources** are composed of non-living inorganic matter. Air, land, water and minerals are examples of this type.

On the basis of status of development, the resources are classified in to **potential resources** and **developed resources**. Potential resources are those which are known to exist and may be used in the future. Until the resource is extracted and put in to use, it remains a potential resource. **Developed resources** are those which have been surveyed and their quality and quantity have been determined for utilisation. The development of resources depends on

technology and level of their feasibility. Petroleum resource from Mumbai High is an example of Developed resources.

Apart from the above classifications, the resources which are available in nature are known as **natural resources** and the one created by man is known as **man-made resource**. Similarly the air like resources which exist everywhere is called as **ubiquitous resources** and the resources which are concentrated only at specific places are known as **localised resources**. This kind of resource may exercise great influence on the economic development of the respective regions.

3.3 Mineral Resources

A homogeneous, naturally occurring substance which has a definite chemical composition is called a mineral. They can be identified by their physical properties and chemical components. Minerals exist in different types based on their formation. Almost everything we use, from a tiny particle to a huge building or a big ship all, is made up of minerals. Minerals are one of the most valuable resources of the earth. All the stages of human development or progress have been named after them. For example, stone age, copper age, bronze age and Iron Age.

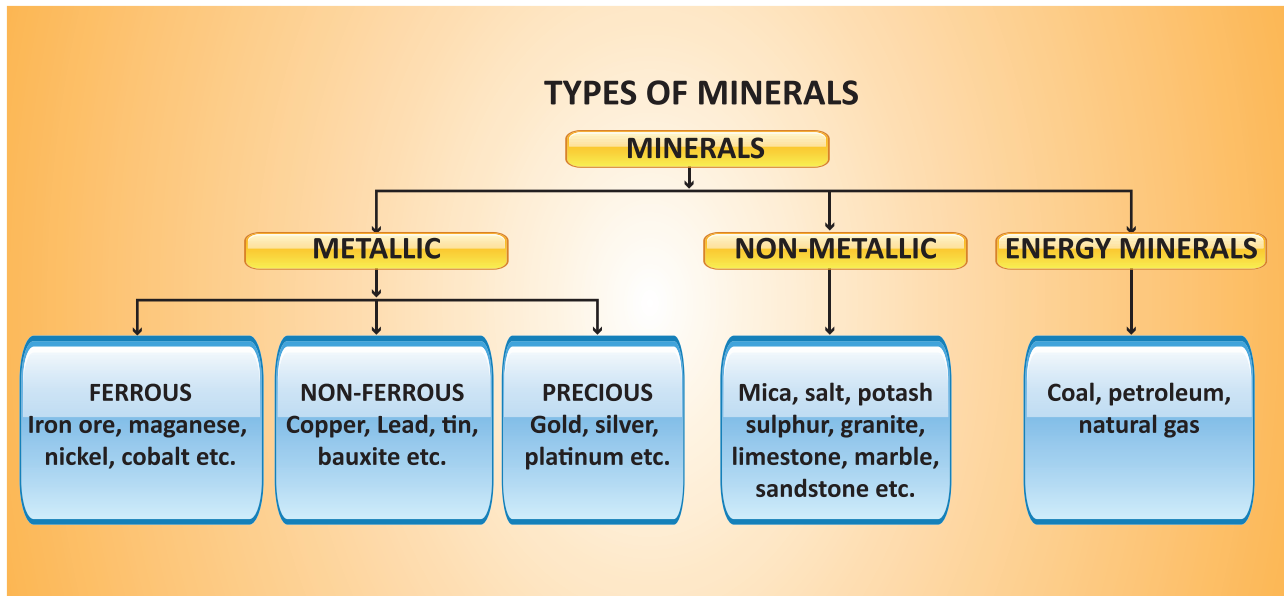

They are exhaustible or non renewable. Besides, they are distributed very unevenly. They are generally found in the form of ores. The ore contains several impurities. Minerals are separated from the ores involving a number of distinct processes.

A country's economic development is depending on the minerals. There are several types of minerals, but according to their characteristics and commercial use they are classified as shown in above chart.

Mode of Occurrence of Minerals

Minerals are generally found in 'Ores'. It is actually an accumulation of any mineral mixed with other elements. Minerals generally occur in many forms. They are

1. Veins and lodes

Minerals generally occur in the cracks, crevices, faults and joints of the igneous and metamorphic rocks. Minerals in smaller occurrence are called a 'Vein' and a larger occurrence is called a 'lode, for example, Copper and Gold are found in lodes and veins.

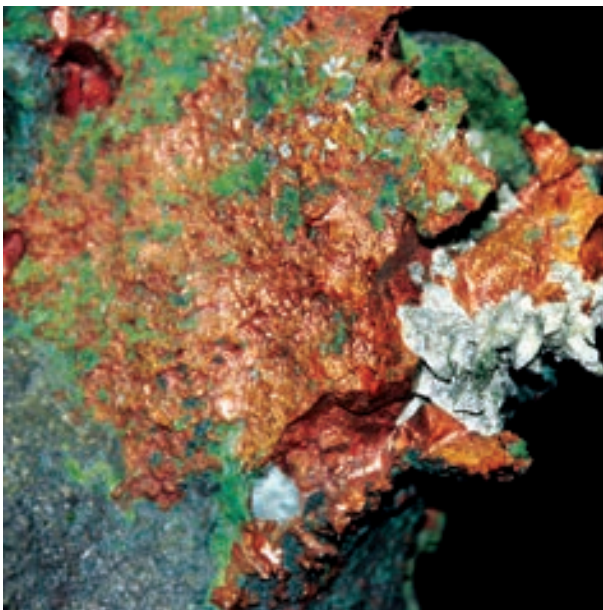

Copper Lodes

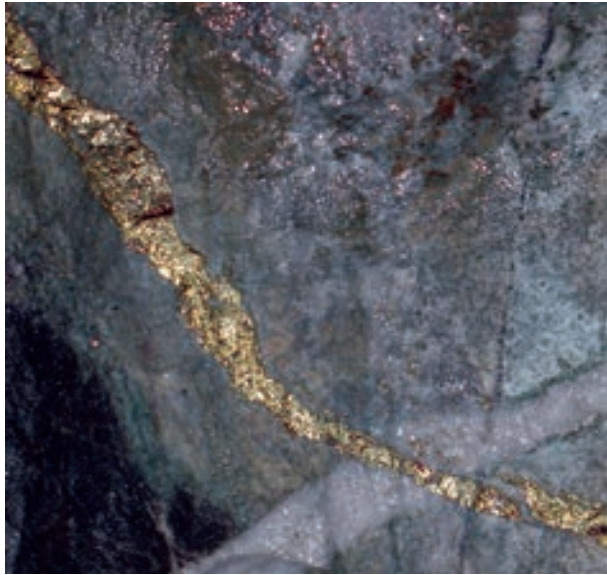

Gold veins

2. Beds or Layers

Minerals that are formed as a result of deposition, accumulation and concentration generally occur in horizontal layers. E.g. Coal, Potash, etc.



Coal



Bauxite

Residual mass of weathered particles

When the decomposed rocks are washed away by water, the soluble particles are removed, leaving a mass containing ores. Such occurrences are called **residual mass**. E.g. Bauxite

3. Alluvial deposits

These are the deposits found in the sands of valley floor and at the foot hills. These deposits consist of the minerals such as Gold, Silver and Platinum.



Platinum

3.4 The world distribution of minerals

Metallic Minerals

The minerals which contain metal in them are called as metallic minerals.

Iron - Ore

It is the basic mineral and the backbone of industrial development of the world. Iron Ore is the most widely distributed element of the earth's crust and it rarely occurs in a free state. It is found as the composition of many rocks and minerals. Iron-ore makes up 4.6% of the earth crusts. Iron is found in the form of Iron - ore. They are classified into 4 categories.

- (i) **Magnetite:** It is red in colour and has 72% of pure Iron
- (ii) **Hematite:** It is black in colour and has 70% of pure Iron
- (iii) **Limonite:** Its colour varies from dark brown to yellow and has 50% of pure iron.
- (iv) **Siderite:** It is brown in colour and contains only 30% of pure iron is present.



The iron content of these ores is highly variable. If the iron content is less than 30% in an ore, it is considered to be uneconomical. Iron is mixed with fixed proportions of Manganese, Nickel, Chromium or Vanadium to make different varieties of steel.

Distribution of Iron ore

Iron - ore is unevenly distributed in the world. Good quality Iron ore is found in Australia, Brazil, Russia, China, USA, Ukraine, Canada, etc. Russia has the largest reserves of iron ore in the world.

Australia is the largest producer of Iron ore in the world. Other leading producers are China, Brazil, India and Russia. The Majority of Iron ore is (84%) produced by 5 countries alone.

Iron ore

Rank	Country	Production (Metric Ton)	Share (%)
1	Australia	531,075,350	33.72
2	China	345,841,000	21.96
3	Brazil	271,275,900	17.22
4	India	124,852,650	7.93
5	Russia	55,550,000	3.53
	Others		15.64

SOURCE: World mining data -2018

IRON ORE PRODUCTION - 2016 SHARE IN %

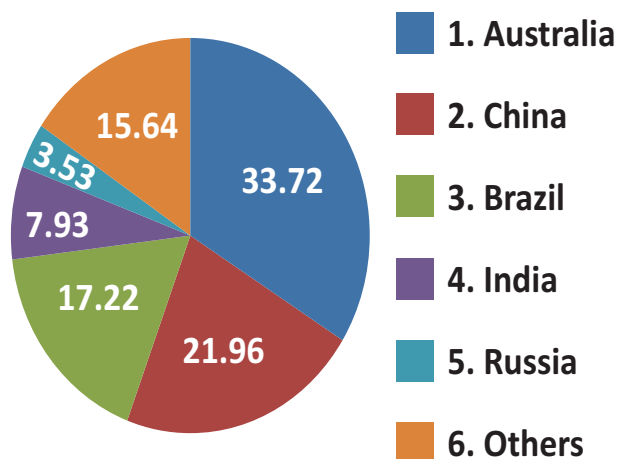

Major Iron ore fields in the world

Country	Iron ore fields
Australia	Mt. Bruce, Mt. Goldsworthy, Mt. Whaleback, etc.
China	Manchuria Region, Shandong, Sinkiang region, etc.
Brazil	Itabira in south east region.
India	Chhattisgarh and Bastar region, Odisha, Chitradurg, Kudremukh, Mayurbhanj region, etc.
Russia	Ural region, Kuzbas, Angara, etc.
U.S.A	Mesabi range, Marquette range, Cornwall, Alabama, Appalachian region, etc.
Germany	Rhur basin.
Ukraine	Krivoi rog.

Manganese ore

It is a kind of Ferro-alloy used to manufacture the special quality steel. A little manganese added to iron, removes gases and acts as a 'Cleanser' in the manufacturing process. Nearly 6 Kg of manganese is used for making one ton of steel.

Manganese is used for special quality steel making; it makes steel anti - corrosive, hard and clean. It helps to increase toughness, strength and durability to resist oxidation in blast furnaces. It is used to produce alloys with Copper, Bronze, and Nickel. It is used for producing heavy machinery, tools, bleaching powder, insecticides and paints.

Distribution and production of Manganese ore

South Africa, Australia, China, Gabon, Kazakhstan, Brazil, India, Ghana, Ukraine and Mexico are the major countries possessing manganese ore. South Africa is the largest producer of manganese ore in the world, followed by Australia. The other leading manganese producers are China, Gabon and Brazil. India is the 8th largest producer of manganese in the world though it possesses the largest reserves of manganese in the world.

Manganese -ore production in 2016

Rank	Country	Production (Metric Ton)	Share (%)
1	South Africa	4,754,560	30.84
2	Australia	2,388,500	15.50
3	China	2,150,000	13.95
4	Gabon	1,658,500	10.76
5	Brazil	1,141,684	7.41
	Others		21.54

SOURCE: World mining data -2018

Copper

It is a non - ferrous, soft brown metal. It is a good conductor, with high luster, density and melting point. Copper occurs in three forms as native metal in its pure state, as oxides and as sulphide.

The chief ore of copper is copper pyrite. It yields nearly 76% of the world production of copper. Copper is extracted by the process of crushing, concentration, roasting, smelting and refining. It was discovered in the earliest stage of civilization. Copper is one of the first metals known and used by man. It is found in the igneous and metamorphic rocks. Copper is very soft, but by mixing with tin, bronze can be obtained and mixing with zinc, brass can be obtained which is harder and tougher than pure copper. Copper is used in

- (i) Electrical Engineering
- (ii) Metallurgical Industries
- (iii) Making of alloys and making tubes, pipes, pumps, radiators and boilers. They are also used in the production of a wide range of ornamental materials.

Production and distribution of Copper

Copper deposits are found in almost every country. The main producers are Chile, Peru, China, USA and Congo. Chile is the largest producer of Copper in the world. It produces 27.20% of the world Copper, followed by Peru, which produces 11.53%. India holds 35th rank and it produces only 0.15% of the world's production.

Copper

Rank	Country	Production (Metric Ton)	Share (%)
1	Chile	5,552,600	27.20
2	Peru	2,353,859	11.53
3	China	1,851,000	9.10
4	United States	1,430,000	7.00
5	Congo	1,035,631	5.07
	Others		40.13

SOURCE: World mining data -2018

COPPER PRODUCTION SHARE IN %

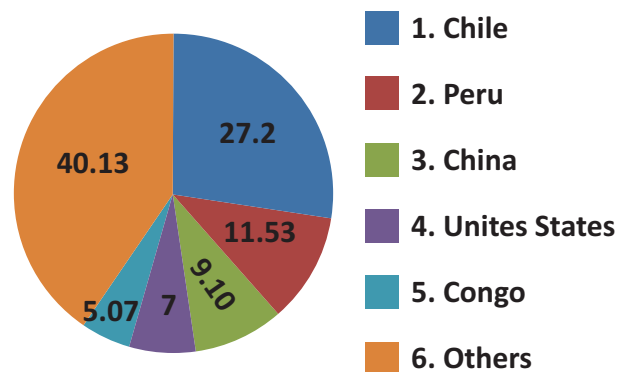

Bauxite

Bauxite is an important ore which is the main source of Aluminum. It is an impure raw material. It generally occurs as an ingredient of chemical compounds in highly complex minerals such as Cryolite, Corundum and Kaolin. Bauxite occurs quite near the surface and is generally mined by open cast method. It has a wide range of applications which include construction of buildings, utensils and airplane parts.

Production and world distribution of Bauxite

The main Bauxite producers are Australia, China, Brazil, Guinea and India. The World's greatest Bauxite producers and exporters are the countries located in the tropical and sub tropical region. Australia is the largest producer of bauxite in the world. India is the 5th largest producer of bauxite in the world.

BAUXITE (ORE)

Rank	Country	Production MT	Share in%
1	Australia	83,516,578	29.31
2	China	65,000,000	22.81
3	Brazil	39,244,200	13.77
4	Guinea	31,117,131	10.92
5	India	24,664,632	8.66
	Others		14.53

Gold

Gold is a precious metal which occurs in alluvial or placer deposits or as reefs or lodes in the underground. Gold is used extensively for jewellery and also in dentistry, glass and porcelain dyes, in medicines and other industries. The purity of gold is expressed in terms of carat. China, Australia, Russia, USA and Canada are the leading producers of gold in the world. I

Gold

Rank	Country	Production MT	Share in%
1	China	453,500	14.11
2	Australia	282,421	8.79
3	Russia	262,380	8.16
4	United states	222,211	6.91
5	Canada	165,034	5.13
	Others		56.90

**GOLD PRODUCTION
SHARE IN %**

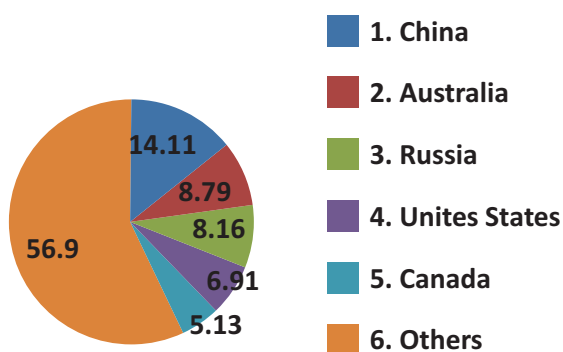

Fool's Gold refers to pyrite of Iron Sulphide because of its similarity in shape and colour to actual gold.

Platinum

Platinum is a rare metal. It is costlier than gold. It has a very high melting point. It is a heavy, malleable, ductile, highly inactive, silverish, white transition metal. It is one of the densest metal almost twice as dense as lead. Platinum is found with other rare metals such as osmium, Palladium, Iridium and rhodium. Platinum is also used in industrial applications. South Africa is the largest producer of platinum in the world. The other leading producers are Russia, Zimbabwe, Canada and USA.

Platinum

Rank	Country	Production Kg	Share in%
1	South Africa	133,241	71.75
2	Russia	21,860	11.77
3	Zimbabwe	15,110	8.14
4	Canada	9,300	5.01
5	USA	3,891	2.10
	Others		1.33

Non-metallic minerals

The minerals which do not contain metal in them are called as non metallic minerals.

Mica

Mica is a Latin word micare means to shine, to flash or to glitter. Mica has a crystalline and layered structure and can be split into very thin sheets. It does not react to water, acids, oil or solvents. It is lightweight, flexible and strong. It can resist extremely high temperatures or sudden changes in temperature and is able to withstand high voltages and insulate with low power loss. It can absorb or reflect light, which enables a decorative effect and protects against ultra-violet (UV) light.

Major Uses of Mica

Mica has several applications. There are several main sectors where the use of mica is identified. They are the paint and coatings sector, Cosmetics and personal care companies, Plastics and printing ink manufactures, the electronics sector, the automotive sector, the construction industry and the oil industry.



Mica

Phosphate

Phosphate occurs in the sedimentary rocks or as phosphate nodules. Another source is bird dropping of Guano. It is the most important source of phosphorus. It is mainly used in fertilizer. China is the largest producer of Phosphate in the world. The other leading producers are Morocco, USA, Russia and Peru. The Guano deposits are found in Peruvian and Chilean deserts in South America. India is the 20th largest producer of Phosphate in the world.

Phosphate (2016)

Rank	Country	Production MT	Share in%
1	China	43,319,400	51.58
2	Morocco	8,601,000	10.24
3	USA	7,615,000	9.07
4	Russia	48,36,000	5.76
5	Peru	4,013,220	4.78
	Others		18.57



Agencies involved in the exploration of minerals in India. GSI, ONGC, MECL, NMDC, IMB, BGML, HCL, NALCO are the departments involved in mining in different states of India.

3.5 Energy Resources

Resources may be classified into renewable and non renewable resources. Mineral resources like coal, Petroleum and natural gas are the exhaustible or non renewable resources. They cannot be reused once they are consumed. Coal and petroleum are the fossil fuels, on which the modern culture relies so much.

Energy gives motion to our industrial machines and vehicles. It is the primary input in the production of goods and services. The wheel of progress moves with the flow of energy. The energy resources may be classified into two types.

(i) Non renewable sources of Energy

Once these resources are used, they cannot be regained again. In other words, they are exhaustible. They are coal, Petroleum natural gas and atomic fuels.

Coal

Coal is a fossil fuel. It is a flammable, black or brown sedimentary rock and is mainly composed of carbon. The dense forest plants were converted into coal due to intense pressure and heat inside the earth by the process of carbonization. Most of the coal resources of the world were formed during the carboniferous period (280 to 350 million years ago). The quality of the coal is determined by its carbon content. The following types of coal have been identified on the basis of their physical properties. They are,

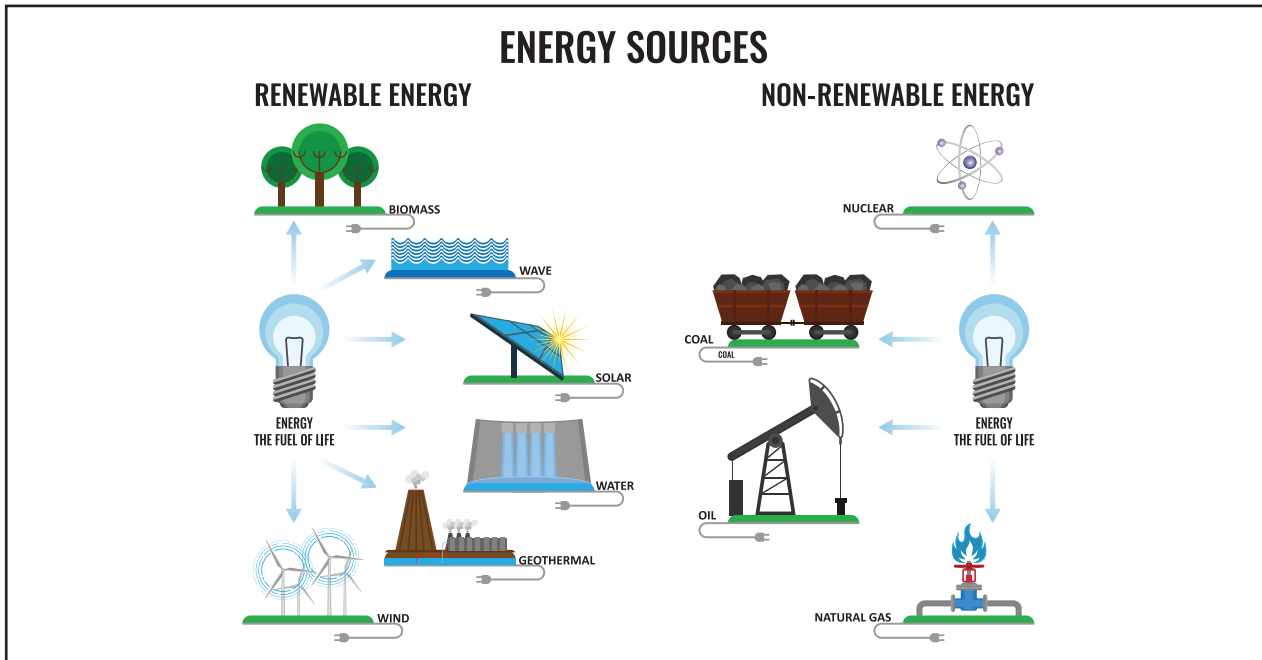

- (i) **Peat** is the first stage of transformation of wood into coal and it has only 30% to 35% of carbon.
- (ii) **Lignite or Brown coal** is the inferior quality and contains 35%-45% carbon
- (iii) **Bituminous or coking coal** is the second best variety of coal and contains 70%-90% of carbon. It is the most widely spread and most widely used variety of coal. It is the most popular coal in commercial use.
- (iv) **Anthracite** is the best quality coal, which contains more than 95% of carbon. It is very hard but emits very less smoke and leaves very less ash. However its deposits are limited.

Production and world distribution of Coal

Coal reserves are found in more than 70 countries of the world but the major coal reserves occur in the USA, Russia, China and South Africa. China is the largest producer of steam coal in the world followed by India. The other leading producers of steam coal are USA, Indonesia, and South Africa etc.

Steam coal – It is used for producing steam and it has high sulphur content

Steam Coal

Rank	Country	Production (Metric Ton)	Share in%
1	China	2,491,793,000	47.42
2	India	601,131,000	11.44
3	United States	553,936,000	10.54
4	Indonesia	459,469,000	8.74
5	South Africa	253,452,000	4.82
	Others		17.04

STEAM COAL PRODUCTION
SHARE IN %

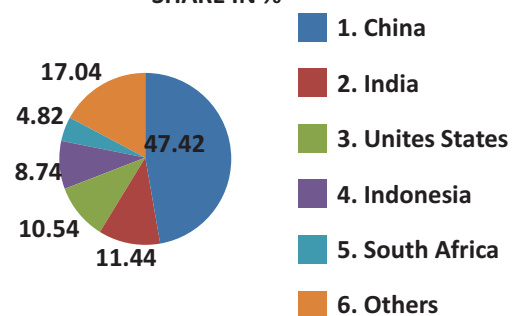

HOTS

Why is hydrogen used as fuel in rockets?

China was the largest producer of coking coal in the world in 2016 followed by Australia. The other leading producers of coking coal are Russia, India and USA.

Coking Coal

Rank	Country	Production MT	Share in%
1	China	591,998,000	54.67
2	Australia	189,302,000	17.48
3	Russia	83,800,000	7.74
4	India	61,661,000	5.69
5	United States	50,645,000	4.68
	Others		9.74

Major coal mining centres

Country	Mining centres
China	Shansi, Shantung, Fushun, Shenyang, etc.
India	Bokaro, Jaria, Korba, Ranikanch, Singreni, etc.
U.S.A	Arkansas, Colorado, Illionois, Indiana, Michigan etc.
Australia	Bowen Basin, Brisbane, Canberra, Sydney, New-castle, Tasmania, etc.
Russia	Moscow-Tula region, Chokot Basin, Ob basin, etc.

Trade

The main exporters of coal in the world are Australia, Indonesia, Russia, Colombia and South Africa and the main importers are China, India, Japan, Korea and Germany.

Uses of Coal

Man has used coal for hundreds of years. But it has gained importance only after industrial revolution. It contributes about 25% of global energy demand. Coal is used for various purposes. It is used as a source of steam energy, electrical energy, domestic fuel, metallurgical coke, chemical industries and byproducts such as Ammonium sulphate, Naphthalene, Phenol, Benzene, etc.

Petroleum (or) Mineral oil

Petroleum is a mineral that exists under the surface of the earth in liquid, solid and gaseous

forms. Liquid petroleum may be in the form of crude oil. The solid form may be mineral waxes or asphalts. The gaseous form is natural gas. It is a main source of energy in the World due to its multiple uses. The human activities are directly or indirectly depend on the use of petroleum or its sub products.

Formation and occurrence of mineral oil

It is formed by residual chemical and bio chemical decomposition of the remains of organic matter in sedimentary rocks. It is found in the pores of the sedimentary rocks. Oil is lighter than water hence, floats over water. Drilling of oil wells is the hole drilled in the earth's crust and when it reaches the rock cap, the natural gas comes out first with a great pressure. When the pressure of gas subsides, petroleum starts flowing out when the pressure of natural gas is released.

Petroleum reserves of the world

The west Asia or Middle East is has the largest petroleum reserves, which is about 60% of the world's oil reserve. The total estimated world's oil reserves in 2008 were 1,243 (10⁹ bbl). Saudi Arabia, Canada, Iran, Iraq and Kuwait have large reserves of petroleum.

Production and world distribution of petroleum

The petroleum producing countries of the world can be grouped in to five geographical regions:

- (i) West Asia (or) middle East region
- (ii) American region
- (iii) Russian region
- (iv) East & south Asian region and
- (v) African region

Saudi Arabia is the largest oil producer of the world with 13.62% of the world output of oil. Russia is the second largest producer in the world. India is placed at 24th position in petroleum production in the world. The distribution of oil is naturally uneven; Middle

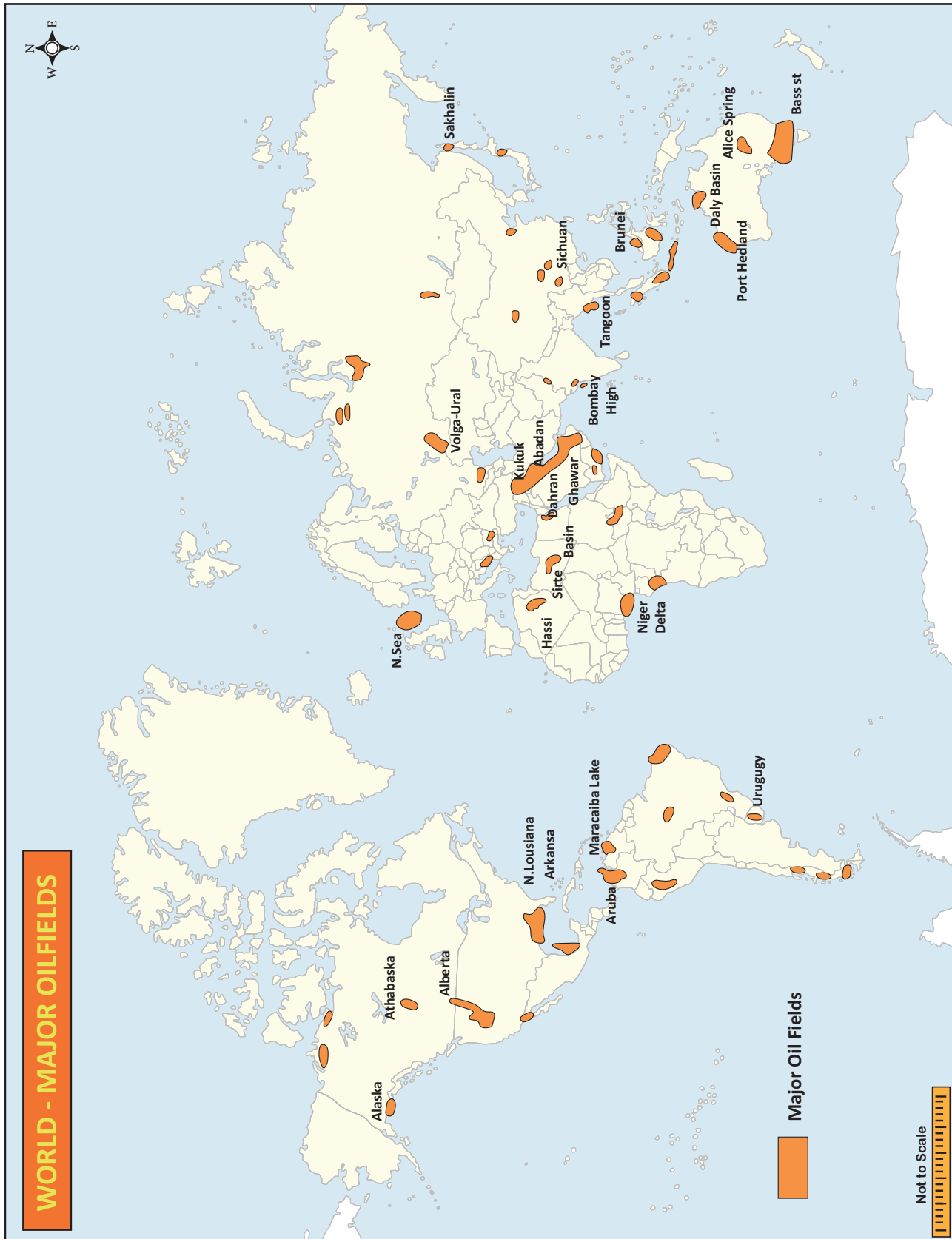

East contains 60% of global reserves and rest of the world only 40%.

Petroleum

Rank	Country	Share in%
1	Saudi Arabia	13.62
2	Russia	12.72
3	USA	12.62
4	Iraq	5.09
5	Iran	5.03
6	China	4.64
	Others	46.28

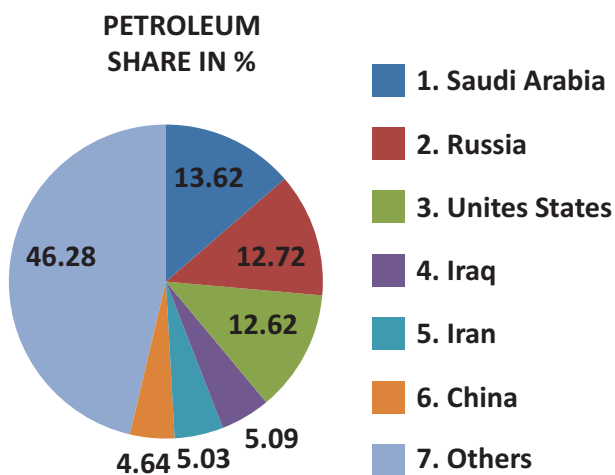

Trade

The world leading exporters of petroleum are Saudi Arabia, Russia, Iraq, UAE and Canada and the main importers are USA, China, India, Japan and Korea.



OPEC is the short form of the "Organisation of Petroleum Exporting Countries. It was formed in 1960 at Bagdad convention. Initially it comprised of Saudi Arabia, Iran, Iraq, Kuwait and Venezuela. Later on added in eight countries Libya, Algeria, Qatar, UAE, Nigeria, Ecuador and Angola, Indonesia left from OPEC in recently.

Major Petroleum production centres

Country	Production centres
Saudi Arabia	Ghawar, Abquiaq, Abu Hadriya, etc.
Russia	Volga- Caspian region, Kamchatka- Sakhalin region, Ob – Lena basin.
U.S.A	Tennessee- New york, ohio, Indiana, Pennsylvania, Texas, Mississippi, Gulf of California, etc.
Iraq	Kirkuk, Mosul, Daura, etc.
China	Taching, Chinchou, yemen, South china sea, etc.

Natural Gas

It is the cheapest source of energy. It is found along with or without petroleum. It is considered as an environment friendly fuel because of its low carbon dioxide emissions. Therefore, this is the only fuel for the present century and it is also called **green energy**. A powerful odorant, ethanethiol is added, so that leaks can be detected easily. It is prepared by refining petroleum or wet natural gas.

Natural gas reserves and Production

The known natural gas reserves in the world is about 6254 trillion cubic feet. Most of these reserves are found in Russia, Iran, Qatar, UAE, Saudi Arabia, USA etc. USA has the largest reserve and is the leading producer of natural gas in the world. India is the 28th producer of natural gas in the world. It is widely used as a fuel in industries and domestic cooking purposes. Petrochemical industries use it as fuel and raw material. It is also used in chemical industries, artificial rubber, plastic, fertilizers, ink and carbon.

Natural gas

Rank	Country	Production (Metric. Ton)	Share (%)
1	United States	755,010	20.56
2	Russia	641,000	17.45
3	Iran	202,440	5.51
4	Qatar	181,250	4.94
5	Canada	157,179	4.28
	Other		47.26

Trade

Russia, Qatar, Norway, Canada and Algeria are the leading exporters of Natural gas in the world. Japan, Germany, China, Italy and Turkey are the leading importers of natural gas.

Nuclear Energy

It is commonly said, this energy holds the key of future. Energy contained within the nucleus of an atom is called nuclear energy. Heavy metals like Uranium, Thorium, Radium, Plutonium and Lithium are the main sources of nuclear energy. However Uranium is the most important source of nuclear energy. The nuclear energy production was started first in USA in 1950. Nuclear energy now provides about 11% of the World's electricity. At present there are more than 450 operable fission reactors in the world. The world's first commercial nuclear power station Calder Hall at Wind scale, England was opened in 1956.

Uranium (U_3O_8)

Rank	Country	Production (Metric. Ton)	Share (%)
1	Kazakhstan	29,113	38.89
2	Canada	16,666	22.26
3	Australia	7,352	9.82
4	Namibia	4,308	5.75
5	Niger	4,101	5.48
	Others		17.80



Most devastating nuclear accidents

1. Three mile Island- March 28, 1979 USA
2. Chernobyl - April 29, 1986, Russia
3. Fukushima Daiich- March 11, 2011, Japan

Renewable sources of Energy:

All regions of the world are facing the twin problems of fast increasing demand for energy and limited supplies and rapidly depleting conventional sources of energy. Under these circumstances, non conventional sources of energy are getting more importance. These sources are renewable, clean and non-polluting. They are solar, wind, geothermal, wave, tidal energy, bio-gas etc.

Hydel Power

Hydro electricity is produced by using the potential energy of water falling from a certain height. The falling water spins the turbine blades and energy is produced. It is a clean eco friendly and renewable source of energy. It contributes nearly 7% of the world electricity production. China has the largest potential followed by Brazil, Indonesia, Canada and Zaire. China is the largest producer of Hydro electricity in the world, followed by Canada.

Solar energy

It is based on mechanical conversion of solar energy into electricity. It is available in abundance but only in the recent period it gets more importance due to technological development. Solar energy is used for various purposes.



Noor Complex is the world's largest concentrated solar power (CSP) plant, located in the Sahara Desert.

CASE STUDY
Kamuthi, the World's largest single solar power plant!

Kamuthi Solar Power Project is a photovoltaic power station spread over an area of 2,500 acres (10 km²) in Kamuthi, Ramanathapuram district. The project was commissioned by Adani Power. With a generating capacity of 648 MW at a single location, The Kamuthi Solar Power Project was completed on 21 September 2016. Around 8,500 workers installed an average of 11 MW of capacity per day to complete the project within 8 months. The entire solar park is connected to a 400 kV substation of the Tamil Nadu Transmission Corp. The solar panels are cleaned daily by a self-charged robotic system.

USA is the major producer of solar cells at present. It is simply the energy provided by the sun, which makes production of solar electricity possible. **Solar power in India** is a fast developing industry. The country's solar installed capacity reached 26 GW as of 30 September 2018. India expanded its solar-generation capacity 8 times from 2,650 MW on 26 May 2014 to over 20 GW as on 31 January 2018. The country added 3 GW of solar capacity in 2015-2016, 5 GW in 2016-2017 and over 10 GW in 2017-2018, with the average current price of solar electricity dropping to 18% below the average price of its coal-fired counterpart.

Wind Energy

The wind is a clean, free and readily available renewable energy source. Wind turbines are capturing the wind's power and converting it to electricity. Wind power has become a pillar in their strategies to phase out fossil and nuclear energy. Wind energy is now the second fastest growing source of electricity in the world. It fulfils about 5% of world's electricity demand. The world's largest wind farm is in Altamont pass in California. India is emerging as a major wind power producer of world. The important wind farms in India - (i). The largest wind farms

in India are Muppandal in Kanyakumari District of Tamil Nadu and Jaisalmer wind park in Rajasthan. They are the first and second largest wind farms of India. Based on the location of its generation it is classified into

1. Onshore wind energy and
2. Offshore wind energy

1. Onshore wind energy –Energy generated from the plants located on the land is known as onshore wind energy. Onshore wind has the advantage of being one of the most affordable renewable energy sources. It is cheaper than any other renewable source of energy but it requires more area to install than any other energy.

2. Offshore wind energy –It refers to the use of wind farms developed in seas and oceans. The largest offshore wind farms are currently in the U.K and Germany. These two countries installed 2/3 capacity. London Array is the largest offshore wind farm in the world. The first offshore wind farm is planned near Dhanuskodi in Tamil Nadu.

Tidal energy - It is a renewable energy powered by the natural raise and fall of ocean water. Its production is very small. The first tidal power station was located in La Rance in France. The largest tidal power station is at Sihwa Lake in South Korea and it is the largest tidal power producer in the world. There are three different category of sources from which the tidal energy is generated. The sources are tidal streams, barrages and tidal lagoons.

India's first attempt to harness tidal power for generating electricity would be in the form of a 3MW plant at the Durgaduani creek in sunderbans delta of West Bengal. The Gulf of Kutch and Cambay in Gujarat and the Ganges delta in sunderbans, the world's largest

mangrove, are the 3 sites identified as potential areas for tidal power generation in India.

Geo Thermal Energy

Geo thermal energy is derived from the natural heat of the earth. The United States is the world's largest producer, and the largest geothermal development in the world is The Geysers north of San Francisco in California, the U.S.

In India, exploration and study of geothermal fields started in 1970. The GSI (Geological Survey of India) has identified 350 geothermal energy locations in the country. The most promising of these is in Puga valley of Ladakh. The estimated potential for geothermal energy in India is about 10000 MW. There are seven geothermal provinces in India: the Himalayas, Sohana, West coast, Cambay, Son-Narmada-Tapti (SONATA), Godavari, and Mahanadi.

3.6 Conservation of Resources

It takes millions of years for the formation of minerals. Compared to the present rate of consumption, the replenishment rate of minerals is very slow. Hence, mineral resources are finite and non-renewable. Due to this, it is important to conserve the mineral resources.



Ways of Conserving Resources

- Controlling population growth will reduce the demand for resources.
- Creating social awareness regarding the importance of conservation of resources.
- Reusing and recycling of resources.

- Using the renewable source of energy as an alternative to non-renewable resources.
- Developing the usage methods which minimize the wastages.
- Propagating the environmental ill effects caused by various products.
- Choosing the products with less packaging.



GLOSSARY

- 1. Mineralogy:** The study of minerals.
- 2. Ubiquitous resource:** resources which exist everywhere
- 3. Alloy:** a metal made by combining two or more metallic elements, especially to give greater strength or resistance to corrosion.
- 4. Lodes:** a vein of metal ore in the earth.
- 5. Exhaustible:** Resources of which a finite quantity is in existence.
- 6. Mineraloids:** A rock with an aggregate of one or more minerals.
- 7. Nuclear power:** The use of nuclear reactions that release nuclear energy to generate heat, produce electricity in a nuclear power plant.
- 8. Silicon material:** Silicon is a chemical element with symbol Si and atomic number 14. It is a hard and brittle crystalline solid with a blue-grey metallic lustre.
- 9. Odorant:** a substance used to give a particular odour to a product.
- 10. Corrosive:** substance that will destroy other substances with which it comes into contact by means of a chemical reaction.

Exercise

I. Choose the correct answer



1. Pick out the statement which is untrue about the renewable resources.

- a) The resources which can always be available for use after their usage.
- b) Resources have natural regeneration and are inexhaustible.
- c) Air, water, solar energy etc are examples for renewable resources.
- d) Available in finite quantities and cannot be obtained once if they are utilized.

2. Identify the one which is untrue about the minerals.

- a) Minerals generally occur in the cracks, crevices, faults and joints of the igneous and metamorphic rocks.
- b) Mineral in smaller occurrence in the joints of the rocks is called a 'Vein'.
- c) Mineral in a larger occurrence in the joints of the rocks is called a 'lode'.
- d) When the decomposed rocks are washed away by water, the soluble particles are removed, leaving a mass containing ores. Such occurrences are called residual mass.

3. Consider the following statements and choose the correct answer.

- i) Good quality Iron ore is found in Australia, Brazil, Russia, China, USA, Ukraine, Canada, etc.
 - ii) Russia has the third largest proven reserves of iron ore in the world.
 - iii) Australia is the largest producer of Iron ore in the world.
 - iv) The Majority of Iron ore is (84%) produced by 10 countries alone.
- a) i) and ii) only b) i) and iii) only
c) iii) and iv) only d) i) and iv) only

4. Which of the following is incorrectly stated?

- a) Saudi Arabia is the largest oil producer of the world.
- b) Russia is the second largest oil producer in the world.
- c) India is the 4th largest producer of oil in the world.
- d) The Middle East countries contain 60% of global oil reserves.

5. Identify the incorrect statement from the following

- a) Peat is the first stage of transformation of wood into coal and it has only 30 to 35% of carbon.
- b) Lignite or Brown coal is the inferior quality and contains 35-45% carbon.
- c) Bituminous or coking coal is the most popular coal in commercial use.
- d) Anthracite is very hard but emits more smoke and leaves very less ash.

6. Consider the following and choose the correct option

Assertion (A): Great dairying regions are located in the wet areas of the cool temperate region.

Reasoning (R): Cool temperate regions have nutritious grass and there is great demand for milk products.

- a) Both A and B are correct but R is not the correct explanation of A.
- b) Both A and B are correct and R is the correct explanation of A.
- c) A is true but R is false.
- d) R is true but A is false.

7. The largest producer of Geo Thermal Energy in the world is

Mineral	Characteristics
----------------	------------------------

- a) Russia
- b) The U.S.A
- c) Canada
- d) China

8. Which of the following statements are incorrect?

- i) Hydropower is a clean eco friendly and renewable energy.
 - ii) It contributes nearly 17% of the world electricity production.
 - iii) China has the largest potential of hydro power followed by Brazil, Indonesia, Canada and Zaire.
 - iv) Canada is the largest producer of Hydro electricity in the world, followed by China.
- a) i, ii, and iii only.
 - b) ii, iii and iv only.
 - c) ii and iv only.
 - d) i and ii only.

9. Which of the following is not a method of conservation of minerals?

- a) Controlling population growth to reduce demand for minerals.
- b) Creating social awareness regarding conservation of minerals.
- c) Reusing and recycling of minerals.
- d) Encouraging the use and acceptance of minerals which are not essential.

10. Pick the Odd one out.

- a) Choose products with less packaging.
- b) Choose products with recyclable or reusable packaging.
- c) Carry use and throw shopping bags or boxes.
- d) Say 'no' to unnecessary plastic bags and other packaging.

II Very short answer

- 11. Differentiate the mode of occurrence of particles of veins and lodes.
- 12. Why is the anthracite coal the best of its kind?
- 13. Name any four leading oil producing countries in the world.
- 14. Mention any two places of tidal energy production in India
- 15. Where is the world's largest wind farm located? Jaisalmer wind park is in which State?

III Short answer

- 16. What are the uses of Mica?
- 17. Write a note on hydelpower.
- 18. State any three uses of copper.
- 19. Mention any three ways of conserving resources.
- 20. Where is the world's single largest solar power plant in the world? Write about the solar energy production in India.

IV Detailed answer

- 21. Classify and describe iron ore.
- 22. List out the methods of conservation of mineral resources.
- 23. In what different ways can resources be reused?
- 24. On the outline map of the world, show the petroleum production centres of the world and write a brief account of them.

V Practice

1. Identify the alternate energy such as wind, solar, geothermal, hydroelectric, bio fuels.

word	symbol	sun
1. Energy generated in a way that does not use up natural resources	2. Resources that can be replaced over time	turbine
word	symbol	biofuel or biomass
3. Resources that are limited and can't be replaced	4. Energy from moving water	renewable resources
word	symbol	alternative energy
5. Energy from once living material	6. Energy from the heat in Earth's core	wind energy
word	symbol	hydroelectric
7. Energy from moving air	8. Energy from the sun	geothermal
word	symbol	nonrenewable resources
9. Machine that produces energy (power) when it is moved by water, wind, or steam	10. Source of Earth's energy	solar energy



Reference

1. Economic and commercial geography, K.K. Khanna and Dr. V.K Gupta
2. Human and economic Geography, Goh Cheng Leong and Gillian C. Morgan



ICT CORNER

RESOURCES

This activity enables the students to enrich themselves about

Resources available in the world and able to categorise them as the headings given in the activities.



Steps

- Type the URL link given below in the browser or scan the QR code. A page opens with many resources available and **“play game”** option.
- It opens with resources on the top and the categorizing buckets at the bottom.
- You have to drag the resources and put them in the bucket. When you drag the resources and drop them in the bucket, the bucket labelled itself for the first droppings.
- After that you have to drag and drop the objects correctly in the bucket.
- After you completed your droppings you click the bucket it gives you the score.



Step 1



Step 2



Step 3



Step 4

Website URL:

<https://www.brainpop.com/games/sortifynaturalresources/>

*Pictures are indicative only.



UNIT 4

Economic Activities



Unit Overview

- 4.1 Introduction
- 4.2 Primary activities
- 4.3 Secondary activities
- 4.4 Tertiary activities
- 4.5 Division of the world on the basis of Economic Activities

Learning Objectives

- Classify the economic activities.
- Understand the relationship between economic development and economic activities.
- Differentiate primary activities from secondary activities.
- Divide the world on the basis of economic activities.



4.1. Introduction

CASE STUDY

Have you heard about Waymo car? A car without brakes, accelerators or steering wheel – a driverless car is indeed a dream come true.

Google started testing self-driving technology with the Toyota Prius on freeways in California in 2009.



A new development was the unveiling of a new prototype vehicle in 2014, capable of being a fully self-driving car. These intelligent cars use sensors and software to detect objects like pedestrians, cyclists and can safely drive around them. According to Google, the car can process both map and sensor information to find out its exact location - precisely which street or lane it is driving in. The sensors are so powerful that it can detect all kinds of objects. What's more interesting, the software can predict what these objects around the car will do next and take action accordingly.

In an instance, where the traffic signal turned green and the car was about to move forward, the car sensed an ambulance coming from the right side and it stopped, making way for the ambulance. Google calls its cars, 'experienced drivers'. Each car's speed is capped safely at 25 mph (40 km/hr). The cars halt for 1.5 seconds after the signal turns green at a junction as many accidents happen during this time.

But the cars can travel as fast as 161 km/hr. To ensure safety, the front side has about 2 feet of foam and the windshield is made of plastic instead of glass. This is the amazing product of secondary industries which we learn about as part of economic activities in this lesson

Economic activity refers to the activity of making, providing, purchasing and selling goods or services. Economic activities exist at all levels within a society. Human beings are engaged in various kinds of economic activities. In general all the economic activities are broadly categorised into Primary, Secondary and Tertiary activities. The Tertiary activities are further sub divided into Quaternary and Quinary activities.

Let us first understand the meaning and concept of the different categories of economic activities.

Types of Economic system:

1. Subsistence economy: Goods and services which are created for the use of the producers and their kinship groups.
2. Commercial economy: Goods and services which are produced mainly for sale. Market competition is the primary force determining the production and distributions.
3. Planned economy: Goods and services created are controlled by government agencies. Supply and price are controlled by the state. It was practiced earlier by the Communist controlled societies.

4.2. Primary activities

Primary activities help man to fulfill his needs and desires, by using resources which are gifted to man by nature. These activities

are directly connected with nature. Hunting, Gathering, Pastoralism, Fishing, Forestry, Mining and Agriculture are the primary activities.

Hunting and Gathering

Until 12,000 years ago, all humans lived as hunters and gatherers. At present only 0.0001% human live as hunters and gatherers. Gathering and hunting are the oldest known economic activity in the world. It often involves primitive societies which collect both plants and animals to satisfy their needs for food, shelter and clothing. These primitive activities are being carried out still in a very few parts of the world. Gathering is practiced in the areas of High altitude zones of Northern Canada, Northern Eurasia and Southern Chile and in the low altitude zones of the Amazon Basin, Tropical Africa, Northern fringe of Australia and interior parts of South East Asia. Present day gatherers and hunters are confined to a few pockets. Inuit in the Arctic region, Pygmies of Kalahari, Pintupi, Aborigines of Australians, and Paliyan of South India are the examples of foragers.

Pastoralism

Pastoralism is the process of grazing and rearing of different types of animals like cattle, sheep, goats, etc in an organised manner to get animals products. The animals rearing can be primitive which is carried on by nomads or highly scientific means on a commercial scale. So, animal grazing and rearing can be divided

into two broad categories as Nomadic Herding and Commercial Livestock Rearing.

Nomadic Herding (or) Pastoral Nomadism

It is a primitive subsistence activity in which the herders rely on animals for food, clothing, shelter, tools and transport. They move from place to place along with their livestock, depending on the availability of pastures and water. These people do not lead a settled life but keep on moving from place to place. Pastoral nomadism is commonly practiced in regions with little arable land, typically in the developing world. They are mostly found in central and western Asia, Northern and Western regions of Africa and some parts of southern Africa and Tundra regions.

Transhumance

Transhumance is the seasonal movement of people with their livestock between fixed summer and winter pastures. In mountain region it implies movement between higher altitude pastures during summer and valleys in winter.



Rearing of Animals

Gujiars, Bakarwals, Gaddis and Bhotiyas in the Himalayan region migrate from plains to the mountain in summer and to the plains from the high altitude pastures in winter. In the tundra regions, herders move from south to north in summer and from north to south in winter. The number of pastoral nomads has been decreasing and the areas operated by them shrinks due to developments and spreading of other economic activities.



Agriculture

Agriculture is the most fundamental form of human activity and includes not only cultivation of crops but also the domestication of animals. The following are the major agricultural types and their characteristic features.



Employees of the economic activity called as	
Economic Activity	Name
Primary	Red collar
Secondary	Blue collar
Tertiary	Pink collar
Quaternary	White collar
Quinary	Gold collar

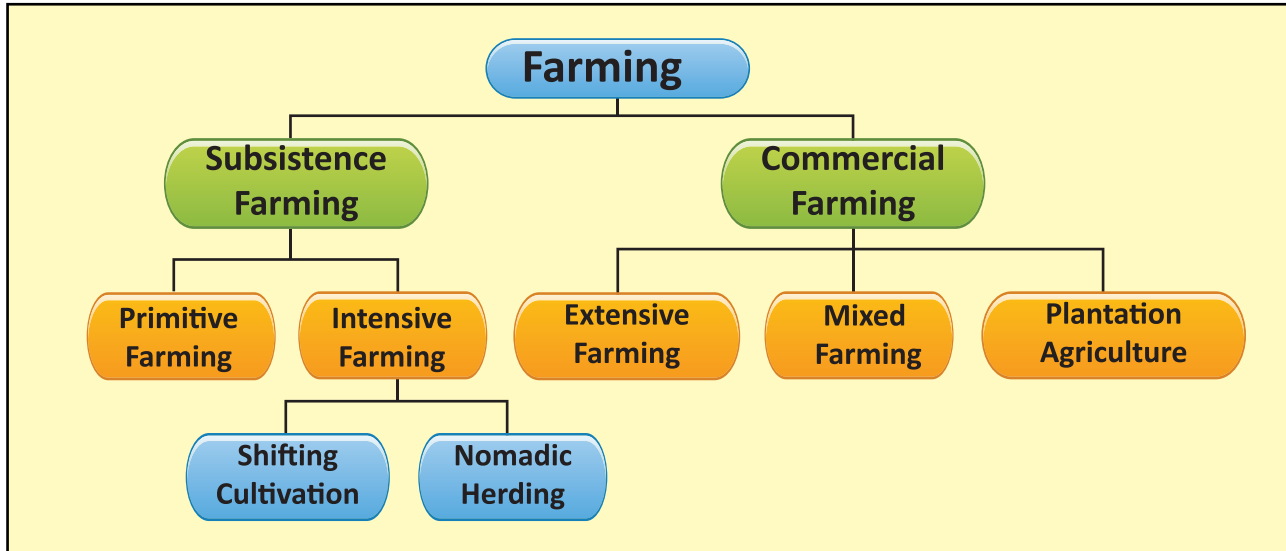

Subsistence Agriculture is a type of farming in which output is consumed almost entirely by the farmers and their families leaving only a small

proportion for sale. Farmers follow traditional method of cultivation in this kind of farming.



Shifting Cultivation

Shifting Cultivation is a kind of traditional farming practiced by tribes in the hilly and forest regions. It is practiced especially in tropical Africa. In this

farming an area of ground is cleared of vegetation and cultivated for a few years and then abandoned for a new area until its fertility has been naturally restored. They are called with different names in different regions.



S. No	Name	Region
1	Jhuming / Bewar	North eastern states of India
2	Ladang	Malaysia
3	Chengin / Kaingin	Philippines
4	Milpa	Central America and Mexico
5	Konuko	Venezuela
6	Roca	Brazil
7	Masole	Congo
8	Ray	Vietnam
9	Humah	Indonesia
10	Taungya	Myanmar
11	Chen	Sri Lanka

Intensive Agriculture is the one in which the agricultural land is utilised intensively. Farmers prefer the cultivation of short duration crops which enables the cultivation of two or

three crops in the same piece of land in a year. Generally it is practiced wherein the size of the agricultural land holding is small.





Extensive Farming

It is a kind of farming practiced in the regions where the size of the land holding is very large. It is practiced in the Interior parts of semi-arid lands of the mid-latitudes. Wheat is the major crop of this region and the farming is highly mechanized.



Extensive Farming

Mixed Farming

It is an agricultural system in which a farmer conducts different agricultural practice together, such as crops, fishing and livestock. The aim is to increase income through different sources and to complement land and labour demands across the year.



Pomology – The study of growing fruits.

Olericulture – science of vegetable growing.

Floriculture – refers to cultivation of flowers.

Sericulture – refers to Rearing of Silkworms

Viticulture – The study of grape cultivation`



Mixed farming

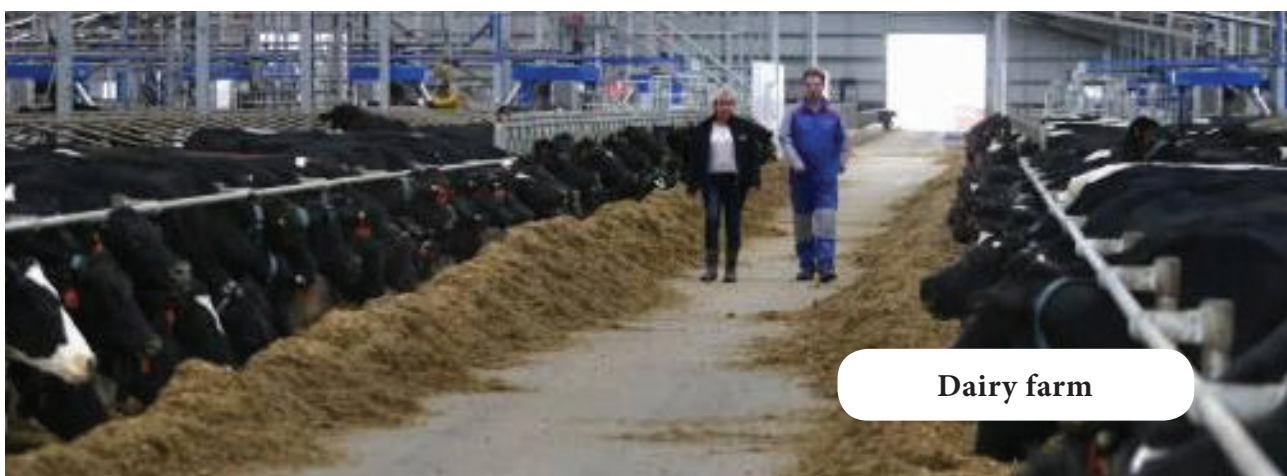

Dairy farm





Plantation Agriculture

Plantation agriculture is a form of commercial farming where crops are grown for profit. Large land areas are needed for this type of agriculture. Countries that have plantation Agriculture usually experience high annual temperatures and receive high annual rainfall. Plantation is mainly found in countries that have a tropical climate. The important plantation crops are tea, coffee, cocoa, rubber, oil palm, sugarcane, bananas and pineapples.



Horticulture

Specialised cultivation of flowers, vegetables and fruits is called horticulture. It is also termed as “truck farming”. These crops are grown on small farms which are well connected to the markets by cheap and efficient means of transportation. It is labour and capital intensive crops. The main areas are northwest Europe, northern eastern USA and Mediterranean region.



Mediterranean Agriculture

Mediterranean agriculture is highly specialised commercial agriculture. It is practised in the countries on either side of the Mediterranean Sea, Europe and in North Africa from Tunisia to Atlantic coast, southern California, central Chile, south western parts of South Africa and south and south western parts of Australia. This region is an important supplier of citrus fruits. Viticulture or grape cultivation is a speciality of the Mediterranean region. Best quality wines in the world with distinctive flavours are produced from high quality grapes in various countries of this region. The inferior grapes are dried into raisins and currants. This region also produces olives and figs. The advantage of Mediterranean agriculture is that more valuable crops such as fruits and vegetables are grown in winters when there is great demand in European and North American markets.

Viticulture

Von Thunen model of agriculture

The Von Thunen model of agricultural land use was created by the farmer, landowner, and economist Von Thunen in 1826 in a book called The Isolated State. Von Thunen model was created before industrialization and is based on the following limiting assumptions:



The city is located centrally within an "Isolated State" that is self-sufficient and has no external influences.

- The Isolated State is surrounded by an unoccupied wilderness.
- The land of the State is completely flat and has no rivers or mountains to interrupt the terrain.
- The soil quality and climate are consistent throughout the State.
- Farmers in the Isolated State transport their own goods to market via ox cart, across the land, directly to the central city. Therefore, there are no roads.
- Farmers act to maximise profits.

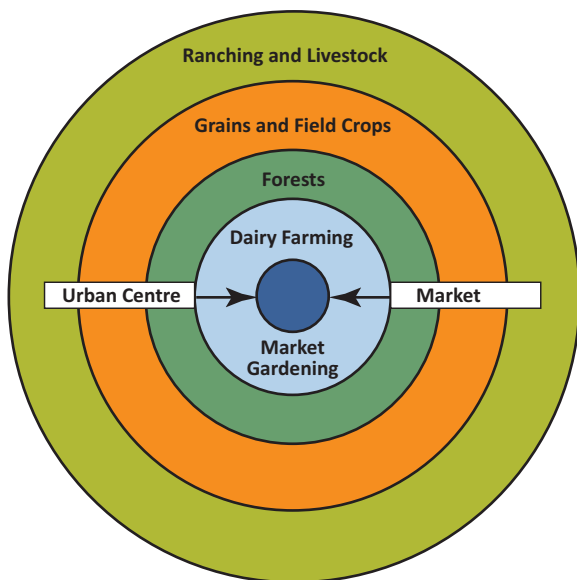

In an Isolated State with the foregoing statements being true, Von Thunen hypothesized that a pattern of rings around the city would develop based on land cost and transportation cost.



The Four Rings

Ring 1: Dairying and intensive farming occur in the ring closest to the city. Because vegetables, fruit, milk, and other dairy products must get to market quickly, they would be produced close to the city. The first ring of

land is also more expensive, so the agricultural products would have to be highly valuable ones and the rate of return is maximized.

Ring 2: Timber and firewood would be produced for fuel and building materials in the second zone. Before industrialization and coal power, wood was a very important fuel for heating and cooking. Wood is very heavy and difficult to transport, so it is located as close to the city as possible.

Ring 3: The third zone consists of extensive field crops such as grains for bread. As grains last longer than dairy products and they are much lighter than fuel, to reduce transport costs, they can be located farther from the city.

Ring 4: Ranching is located in the final ring surrounding the central city. Animals can be raised far from the city because they are self-transporting.

What the Model Tells Us?

Even though the Von Thunen model was created in a time before factories, highways, and even railroads, it is still an important model in geography. The Von Thunen model is an excellent illustration of the balance between land cost and transportation costs. When one gets closer to a city, the price of land increases. The farmers of the Isolated State balance the cost of transportation, land, and profit and produce the most cost-effective product for market. Of course, in the real world, things do not happen as they would in a model.

Mining

The process of extracting minerals from the earth crust is known as mining. The discovery of minerals in the history of human development is reflected in many stages in terms of copper, Bronze and Iron age. The use of minerals in ancient times was largely confined to making of tools, utensils and weapons. The actual development of mining began with the industrial revolution and its importance is continuously increasing.

Types of Mining

Open-pit or opencast mining

Open pit mining involves mining minerals ore that can be found near the surface layer of the site. Some quarries can be over 1000 meters deep. This form of mining doesn't require tunneling into the earth and is a simple method of mining that yields high production.

Surface Mining

Surface mining is the process of mining the ores found on the surface of the earth. In this process, any unwanted soil is stripped off from the land and the ore beneath is extracted. Surface mining often leaves behind large areas of infertile land and waste rock as 70% of the mined earth is waste materials.

Underground or sub surface mining/Shaft mining

Sub-surface mining involves the digging of a network of shafts and tunnels into the earth to reach and extract the deposit of mineral ore beneath the earth. In comparison to other methods, underground mines impacts are less on the environment and are more harmful to those working within them. In modern practice, underground mines are pre-assessed for oxygen toxicity levels and a system of ventilation machines and protocols are in place to ensure workplace safety.

In-Situ Mining

It is a rarely used method of mining material. It is also called as solution mining. It is the process of pumping a solution into the ore body, which dissolves the ore and is then extracted by a second pump. This method is used most in mining uranium deposits.



Drilling

4.3 Secondary Activities

Secondary sector transforms the raw materials obtained from the primary sector into consumer goods. So it consists of manufacturing and industrial activities. Since it adds value for the raw materials, it is also called as value addition sector. Industries consume large quantities of energy and require factories and machinery to convert the raw materials into goods and products. The secondary sector supports both the primary and tertiary sectors.

Factors affecting location of Industries

- 1. Availability of raw-materials or nearness to raw-materials:** Availability of raw materials or nearness to raw materials is a primary factor which governs location of industries. An industry is located in a place where raw materials are available in abundance and at cheaper rates. It is more so for the weight loosing and bulky raw materials. For example, oil refinery factories are established at Visakhapatnam because oil is imported through Vizag port.
- 2. Availability of power:** Availability of power is another important factor of concentration or location of industries. In olden days steam was used for running industries. As

a result industry is established near the coal mines. But with the invention of electricity, today industries are located in any place where electricity is available. Industries like aluminum units are located near the hydroelectric projects.

3. **Transport costs** Transport costs also influence the location of industries. Industries incur transport costs for bringing raw-materials and for sending the finished goods into the markets. It is economical to start an industry near the area where transport costs are minimum and low. Raw-materials which are heavy and occupy large place, require huge cost for transporting them. So an industry must be located near the area where the transport costs are minimal.
4. **Nearness to the market:** This is a chief factor governing the location of an industry in modern period. Several advantages are secured when an industry is established near the market.
5. **Availability of labour:** Labour is required for organizing the productive affairs of an industry. The entrepreneurs like to start industries in those areas where labour is abundantly available. For example The growth of cotton textile industry near Bombay is due to the availability of cheap labour.
6. **Government policy:** The policy of government also influences the location of industries. The Government may establish an industry on political considerations by giving several incentives. It provides finance, land, water, and transport and communication facilities in backward regions with a view to developing them. It also provides tax concession, marketing consultancy, export and import facilities.
7. **Availability of capital:** Capital is the most essential factor for the establishment of an industry in a locality.

Weber's Theory of Location

Weber has developed an industrial location emphasising the least cost principle. This is based on assumptions relating to transport costs and other conditions. From his theory, industrial locations for three different situations are made clear.

Assumptions:

1. Some resources are available only in certain regions. Yet, resources such as water are ubiquitous (present everywhere).
2. Markets are found only in specific places.
3. Transport costs are determined based on the weight of the raw materials and distance of transfer.
4. There is competition in the markets for the commodities produced at the industry.
5. Humans use their discretion in their consumer behaviour in relation to the industrial commodities.

Based on these assumptions, together with the notion of high profits with least costs and imagination, Weber describes his theory of industrial location.

Weber uses a triangular structure to elaborate on his theory of industrial location using least transport cost principle. The two corners of the triangle defined by the base line represent the places where raw materials are found (R1 and R2). The market (M) is at the apex of the triangle. In the figure below, R1 and R2 are resource locations, consisting of two types of resources. M is the market and P is the industrial location.

As the logic behind Weber's location indicates, some industries produce finished products which lose weight (weight losing raw materials). In this case, the transport cost for raw materials transfer to the industrial location is higher than the transport cost of moving

finished products from industrial location to market. It is because the waste from raw materials at the industrial site will be high. Hence, it is profitable to have industry at the raw materials' locations.

If industry is located at the raw material source R1, then raw material R2 must be

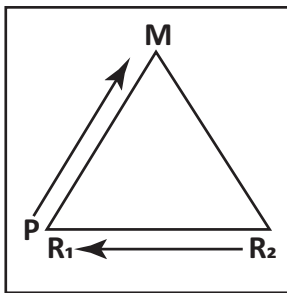

transported to industrial location R1 and the finished products must be transported to the market M. This results in transport costs.

Likewise the industry could be located at R2, too. But if it is located at M, R1 and R2 resources must be transported to market M. This would also involve transport

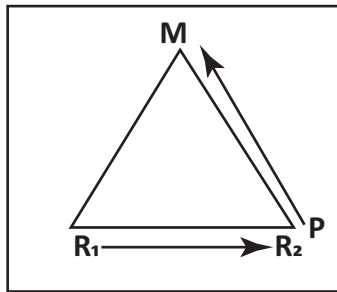

costs. If on the other hand, the industry is located half way between R1 and R2, and then the transport cost to bring the raw materials from

R1 and R2 is equal. Transport cost involved in transporting the finished products to the Market decreases because of small distance to market M (if transport cost is assumed to increase with distance).

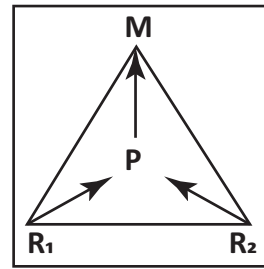
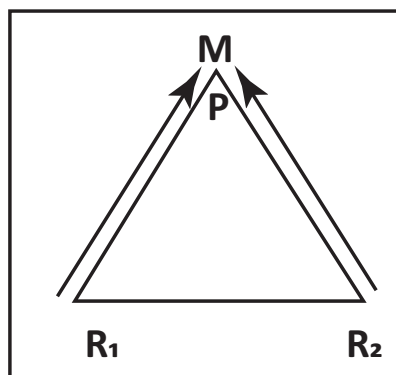

In the final analysis, the transport cost for raw materials to the industrial location P and the finished products to market M from P together is the least when industry is located at P.

There is thus a chance for increased profit for the industry.

The triangle at top left represents a location where distance to be covered by transport is at minimum, the triangle at the top right illustrates the location of a 'weight - losing industry' and the triangle at the bottom left represents the location of a 'weight - gaining industry'. Hence, the location of industry at P is an 'optimal industrial location'.

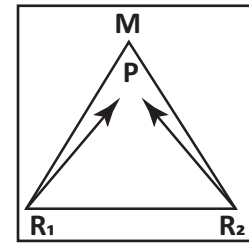
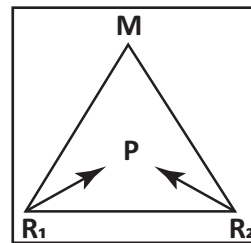

As the industry is located at a point between the raw materials locations, transport cost to transfer bulky raw materials is reduced considerably. The transport cost for transferring the finished products from the industry to the market is also small. In such a context, Weber believes that it is profitable to set up the industry at a location in between the industry.

There are some industries which manufacture finished products gaining weight in the process. The transport cost between raw materials location and industry is lower than the transport cost of finished products from industrial location to the market. It is logical therefore to locate the industry at the market. According to Weber, this location is more

profitable to the industry than any other. The Weber's location theory is that it is based on the transport cost. Nevertheless, this theory

of industrial location is considered superior to other industrial location theories for its logical conclusion.

Classification of Industries

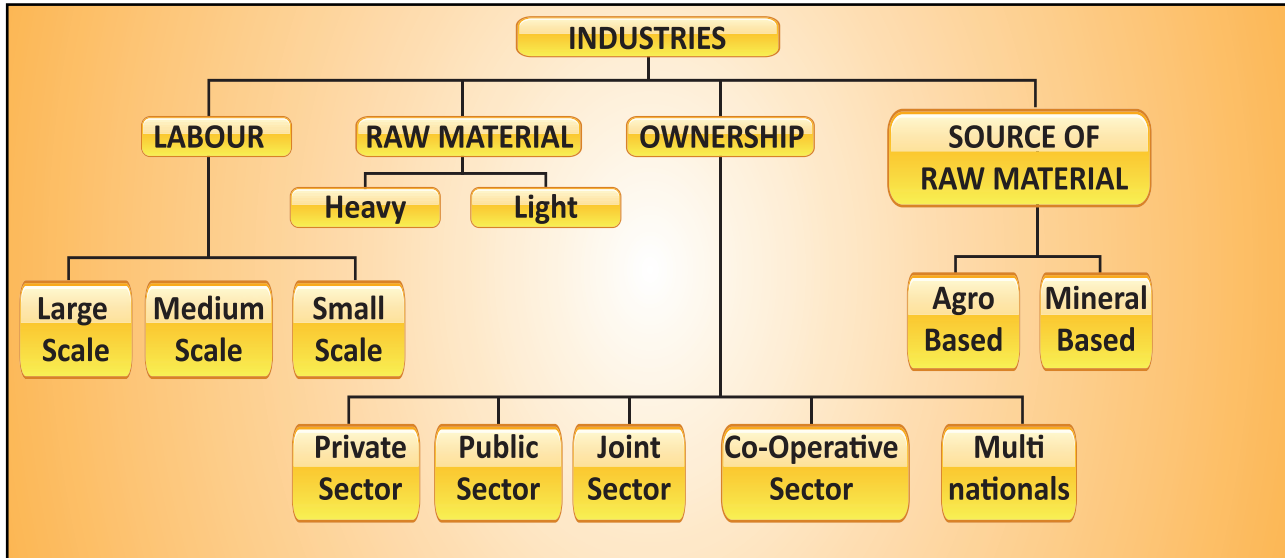

On the Basis of Labour

Large Scale Industries

Industries which employ a large number of labourers with huge capital are called large-scale industries. Cotton and jute textile industries are large scale industries.

Small Scale Industries

Industries which employ a small number of labourers with small investments are called small scale industries. They include nut & bolt making, coir making, plastic bags industries, dying industry, match box making, weaving industry are some examples for small scale industries

Cottage Industries

Those industries whose labour force consists of family units or individuals working at home with their own equipments are called cottage industries. It is a small and often informally organized industry. The industries like weaving and pottery are the examples this category. On the Basis of size of raw-Material and Finished Goods

Heavy Industries

Industries which use heavy and bulky raw-materials and produce products of the same category are called heavy industries. Iron and steel industry presents a good example of heavy industries.

Light Industries

The light industries use light raw-materials and produce light finished products. Electric fans, sewing machines are light industries.

On the basis of Ownership

Private Sector Industries

Industries owned by individuals or firms such as Bajaj Auto or TISCO situated at Jamshedpur are called private sector industries.

Public Sector Industries

Industries owned by the state and its agencies like Bharat Heavy Electricals Ltd., or Bhilai Steel Plant or Durgapur Steel Plant are public sector industries.

Joint Sector Industries

Industries owned jointly by the private firms and the state or its agencies such as Gujarat Alkalies Ltd., or Oil India Ltd. fall in the group of joint sector industries.

Co-operative Sector Industries

Industries owned and run co-operatively by a group of people who are generally producers of raw materials of the given industry such as a sugar mill owned and run by farmers are called co-operative sector industries.

On the Basis of Source of Raw Materials

Agro Based Industries

Agro based industries are those industries which obtain raw-material from agriculture. Cotton textile, jute textile, sugar and vegetable oil are representative industries of agro-based group of industries.

Mineral Based Industries

The industries that receive raw materials primarily from minerals such as iron and steel, aluminium and cement industries fall in this category.

Pastoral-Based Industries

These industries depend upon animals for their raw material. Hides, skins, bones, horns, shoes, dairy, etc. are some of the pastoral-based industries.

Forest Based Industries

Paper card-board, lac, rayon, resin, tanning of leather, leave- utensils, basket industries are included in this type of industries.

Classification based on Nature of products

Based on the nature of products it is classified into basic industries and consumer

goods. Basic industries are manufacturing goods by using them as raw materials are basic industries. For example Iron and steel machines for textile industry. Consumer industries are producing goods for consumers. For example, Television, soap, biscuits, etc

4.4 Tertiary activities

The tertiary industry provides services to its consumers. It is also known as service industry/sector.

All types of services and special skills provided in exchange of payments are called tertiary activities. Health, education, law, governance and recreation etc; require professional skills. These services require other theoretical knowledge and practical training. Most of the tertiary activities are performed by skilled workers and professionally trained experts and consultants.

Tertiary activities involve commercial output of services rather than the production of tangible goods. Expertise provided by service relies more heavily on special skills, experience and knowledge of the workers rather than on the production techniques, machinery and factory processes. Trade and commerce, transport, communication and services are the categories of tertiary sector. Tertiary sector is further divided into quaternary and quinary sector.

Quaternary Activities

The quaternary sector of the economy consists of intellectual activities, example, libraries, scientific research, education, and information technology. The workforce who is readily involved in this sector is typically well-educated, and people are often seen earning well through their participation in this industry.

Quinary Activities

The professions of the people working in this industry are generally referred to as "gold

collar" professions since the services included in the sector focus on interpretation of existing or the new ideas, evaluation of new technologies, and the creation of services. It involves highly paid professionals, research scientists, and

government officials. The people are designated with high positions and powers, and those who make important decisions that are especially far-reaching in the world around them often belong to this category.

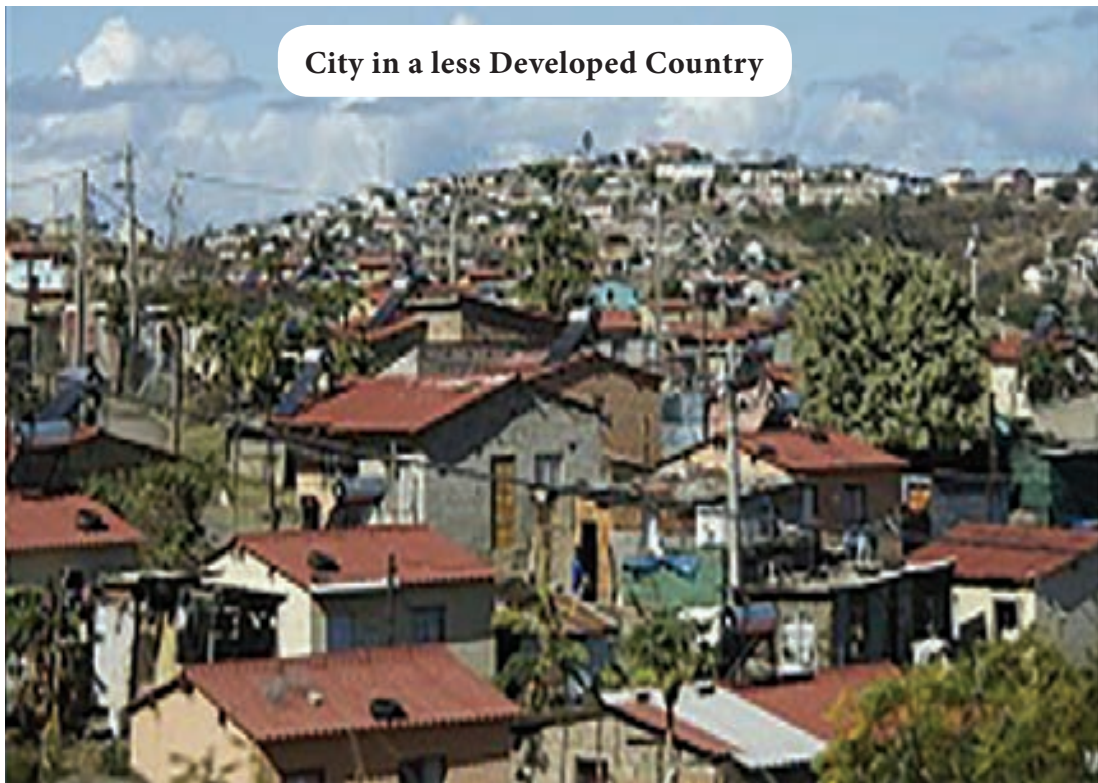

City in a less Developed Country

HOTS

Why most of the developed countries are located in the northern hemisphere?

4.5 Division of the world on the basis of Economic Activities

For analytical purposes, World Economic Situation and Prospects classifies (WESP) all countries of the world into one of three broad categories: **developed countries**, **countries in transition** (South-Eastern Europe Commonwealth of Independent States and Georgia) **less developed countries**.

The classification of countries is based on the economic status such as Gross Domestic Product (GDP), Gross National Product (GNP), per capita income, industrialization, the standard of living,

etc. Developed Countries refer to the sovereign state, whose economy has highly progressed and possess great technological infrastructure, as compared to other nations.

Developed countries

A developed country, industrialized country, more developed country, or more economically developed country (MEDC), is a country that has a developed economy and advanced technological infrastructure relative to other less industrialized nations. Most commonly, the criteria for evaluating the degree of economic development are gross domestic product (GDP), gross national product (GNP), the per capita income, level of industrialization, amount of widespread infrastructure and general standard of living.





City in a Developed Country



Countries in transition

Developed countries have generally post-industrial economies, meaning the service sector provides more wealth than the industrial sector. As of 2015, advanced economies comprise 60.8% of global GDP based on nominal values and 42.9% of global GDP based on purchasing-power parity (PPP) according to the International Monetary Fund. In 2017, the ten largest advanced economies by GDP in both nominal and PPP terms were Australia, Canada, France, Germany, Italy, Japan, South Korea, Spain, the United Kingdom, and the United States.

A country in transition economy or transitional economy is an economy which is changing from a centrally planned economy to a market economy. Transition economies undergo a set of structural transformations intended to develop market-based institutions. These include economic liberalization, where prices are set by market forces rather than by a central planning organization. The process has been applied in the former Soviet Union and Eastern bloc countries of Europe and some Third world countries, and detailed work has been undertaken on its economic and social effects.



Developed Economies

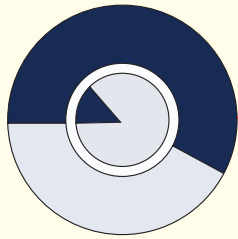

Share of the world

GDP per capita growth

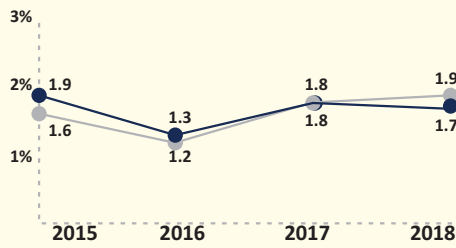

GDP growth

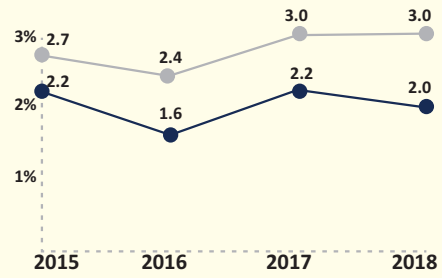

GDP per capita

\$10,600

\$43,700

■ Developed Economies
■ World

Economies in transition

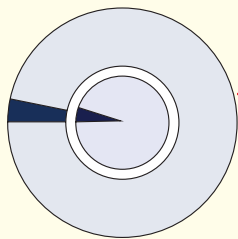

Share of the world

GDP per capita growth

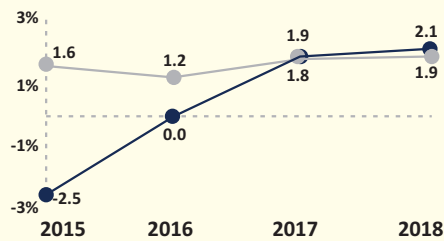

GDP growth

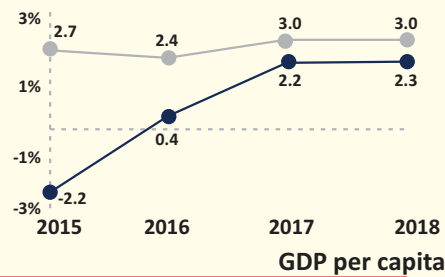

2017 \$10,600

\$7,100

■ Economies in Transition
■ World

The Least Developed Countries

The **Least Developed Countries** is a list of countries that, according to the United Nations, exhibit the lowest indicators of socioeconomic development, with the lowest Human Development Index ratings of all countries in the world. A country is classified among the Least Developed Countries if it meets three criteria.

- Poverty – adjustable criterion based on GNI per capita averaged over three years. As of 2018 a country must have GNI per capita less than US\$1,025 to be included on the list, and over \$1,230 to graduate from it.
- Human resource weakness (based on indicators of nutrition, health, education and adult literacy).
- Economic vulnerability (based on instability of agricultural production, instability of exports of goods and services, economic importance of non-traditional activities, merchandise export concentration, handicap of economic smallness, and the

percentage of population displaced by natural disasters).

The world's 10 biggest economies in 2015

The economy of the **United States** is the largest in the world. At **\$18** trillion, it represents a quarter share of the global economy (24.3%), according to the latest World Bank figures.

China follows, with **\$11** trillion, or 14.8% of the world economy. Japan is in third place with an economy of **\$4.4** trillion, which represents almost 6% of the world economy. European countries take the next three places on the list: **Germany** in fourth position, with a **\$3.3** trillion economy; the **United Kingdom** in fifth with **\$2.9** trillion; and **France** in sixth with **\$2.4** trillion. **India** is in seventh place with **\$2.1** trillion, and **Italy** in eighth with an economy of over **\$1.8** trillion. Ninth place goes to **Brazil**, with an almost **\$1.8** trillion economy. And in 10th is **Canada**, with an economy of over **\$1.6** trillion. The economy of the United States is larger than the combined economies of numbers three to 10 on the list.

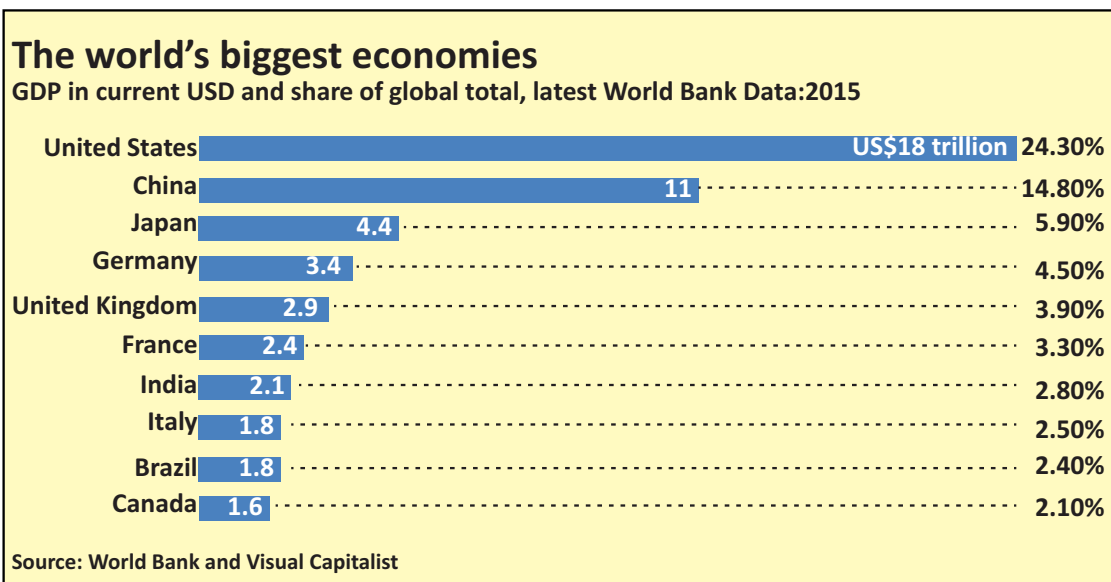

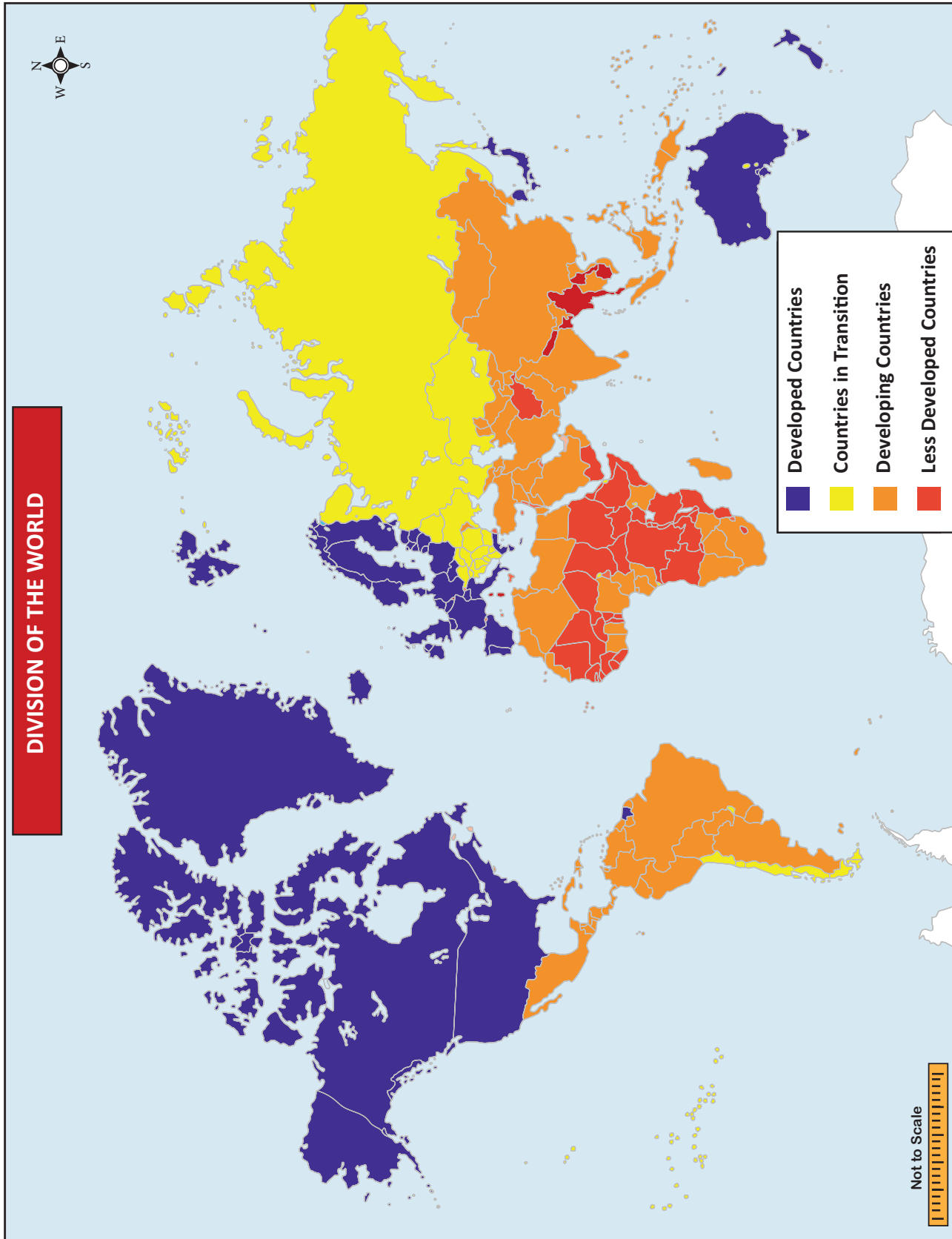

Fastest-growing economy

Although China trails the US by \$7 trillion, it's catching up. China's economy grew by 6.7% in 2016, compared with America's 1.6%, according to the IMF. It has also overtaken India as the fastest-growing large economy. The IMF's World Economic Outlook estimated China's economy grew at 6.7% in 2016, compared with India's 6.6%. The chart above shows the world's 40 biggest economies individually, but grouped by colour into continents. The Asian bloc clearly has a larger share than anywhere else, representing just over a third (33.84%) of global GDP. That's compared to North America, which represents just over a quarter, at 27.95%. Europe comes third with just over one-fifth of global GDP (21.37%). Together, these three blocs generate more than four-fifths (83.16%) of the world's total output.

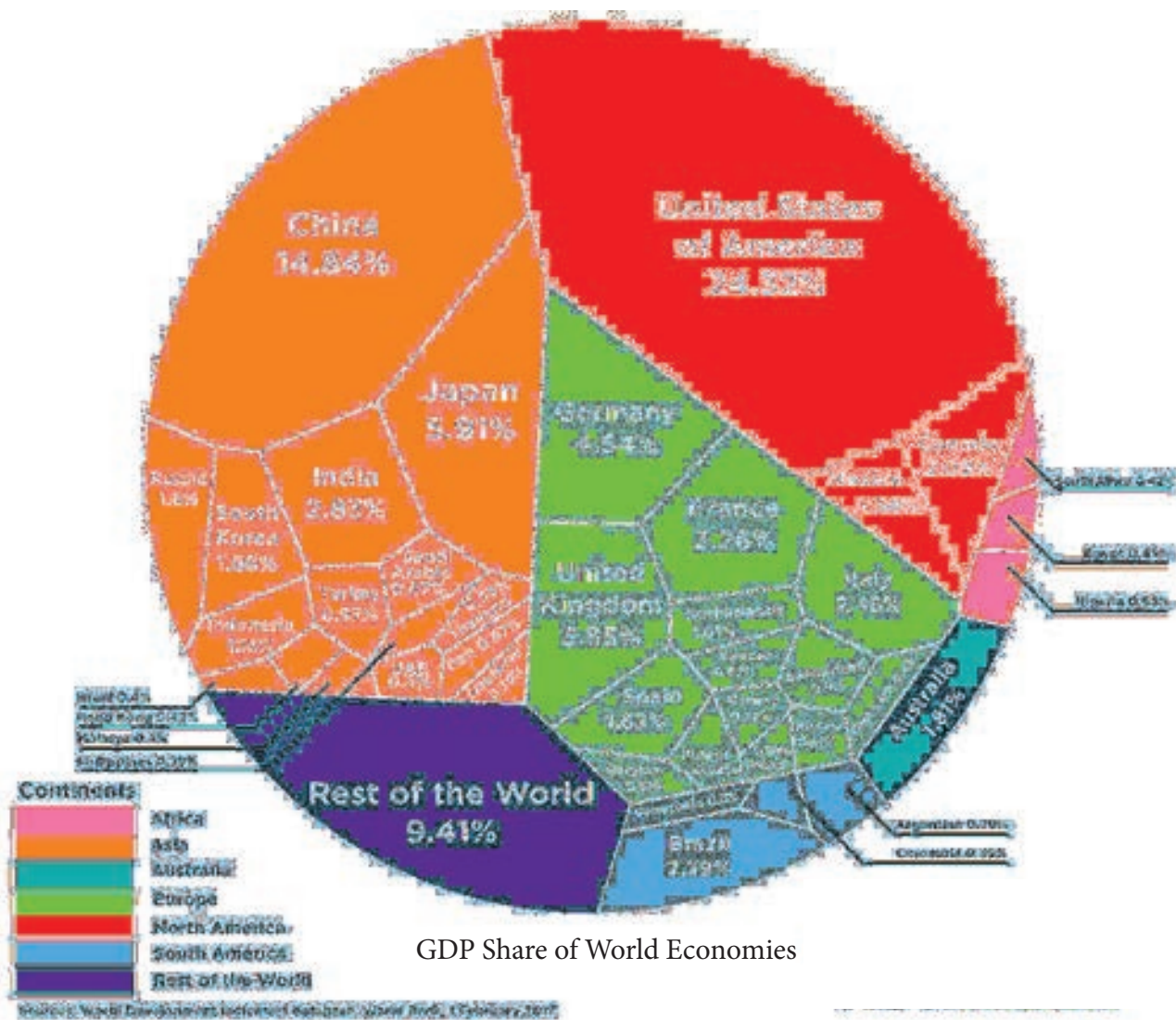



1. **Quarries** – Large deep pit stone and other materials are extracted from.
2. **Sovereign state** - state with borders where people live, and where a government makes laws and talks to other sovereign states.
3. **Shellac** - resin secreted by the female lac bug, on trees in the forests
4. **Debt** - a sum of money that is owed or due.
5. **Protocol** - a set of rules that governs the communications between computers on a network.
6. **Malnutrition** - Lack of sufficient nutrients in the body.
7. **Poverty** - the state of being extremely poor.
8. **Gross domestic Product** - the final value of the goods and services produced within the geographic boundaries of a country during a specified period of time
9. **Standard of living** - the degree of wealth and material comfort available to a person or community.
10. **Gross National Product (GNP)** - the value of all finished goods and services produced in a country in one year by its nationals.

Exercise

I. Choose the correct answer

1. **Viticulture or grape cultivation is a speciality of**
 - a) The Pampas region b) The savannah region
 - c) The Sahara region d) The Mediterranean region
2. **Which of the following consists of only the developed countries?**
 - a) Australia, Kenya, Pakistan, Germany and Italy
 - b) Australia, Canada, France, Germany and Italy
 - c) Australia, Sri Lanka, Thailand, Germany and Italy
 - d) Pakistan, Sri Lanka, France, Germany and Italy
3. **Identify the one which is incorrectly matched.**
 - a) Foragers — Region
 - b) Inuit — Arctic region
 - c) Pygmies — Kalahari
 - d) Aborigines — South America
 - e) Paliyan — South India



4. As per the Vonthunen's agriculture model, the order of the rings from the urban centre is

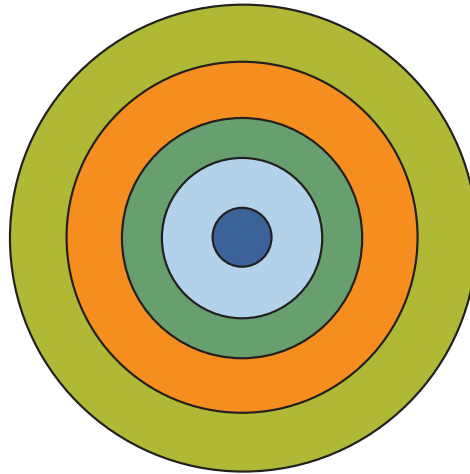

- a) Grains and Field crops, Market, forests, dairy farming and ranching.
 b) Forests Market, Grains and Field crops dairy farming and ranching.
 c) Market, dairy farming, forests, Grains and Field crops and ranching.
 d) Ranching, Market, forests, Grains and Field crops and dairy farming.
5. Which of the following is not the characteristic of the Least Developed countries?
 a) low Gross Domestic Product b) high literacy rate
 c) unequal distribution of income d) high level of unemployment
6. Which of the following is not the assumptions of Vonthunen's model of agriculture?
 a) The Isolated State is surrounded by an unoccupied wilderness.
 b) The land of the State is completely flat and has no rivers or mountains to interrupt the terrain.
 c) The soil quality and climate are not consistent throughout the State.
 d) Farmers act to maximize profits.
7. Identify the one which is incorrectly matched?
 a) Heavy industry - Iron and steel industry
 b) Light industry - Sewing machines industry
 c) Private industry - Bhilai steel plant
 d) Public sector industry - Bharat Heavy Electricals Ltd
8. Which of the following is not the characteristics of the Developed countries?
 a) lower per capita income
 b) better housing and living conditions
 c) high GDP
 d) infrastructural and technological advancement

9. Which of the following diagrams indicates profitable industrial location?

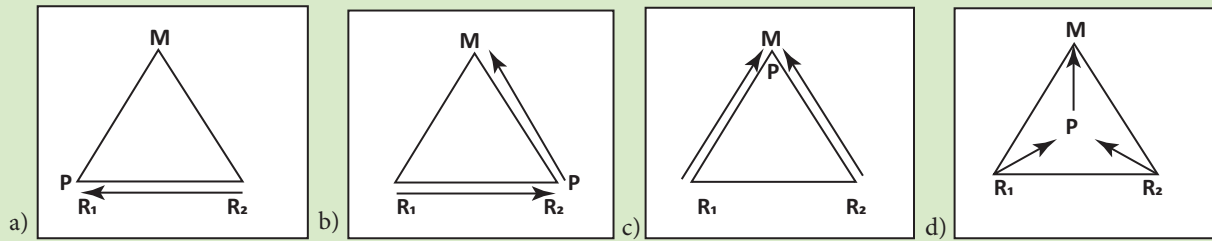

10. Which one of the following is not a plantation crop?

- a) tea b) coffee
c) corn d) cocoa

II Very short answers

- How do you differentiate plantation agriculture from extensive farming?
- Define transhumance.
- What is intensive agriculture?
- Differentiate Quaternary and Quinary sector.
- Write a short note on cottage industries.

III Short answers

- Differentiate subsistence agriculture from commercial agriculture.
- List out the factors which affects the location of industries.
- Why are secondary industries more important than primary industries?
- Define shifting cultivation. Name the regions where this type of farming is practiced.
- Write any three assumptions of Vonthunen's agriculture model.

IV Detailed Answers

- On the basis of labour, source of raw materials, and ownership classify the industries and explain any two types of industries.
- Elucidate Weber's Industrial location theory with suitable diagrams.
- Explain any three characteristics of the developed and the least developed countries.
- On the outline map of the world mark the developed and underdeveloped countries and write a short note of it

V Practice

- Read carefully and answer the following.

Where and what are the developing countries?

The map of the world given below shows the division between the rich developed countries of the north and the poor developing countries of the south.

- Lightly shade the rich countries in Red and the poor countries in Green.

b) Name the equator and the two tropics.

c) 12 of the world's developing countries are written in box below. Each is located on the map by its first letter.

Bangladesh, Nigeria, Kenya, Egypt, Pakistan, Brazil, China, Venezuela, India, Mexico, Peru, Ghana.

Write each name in full on the map.

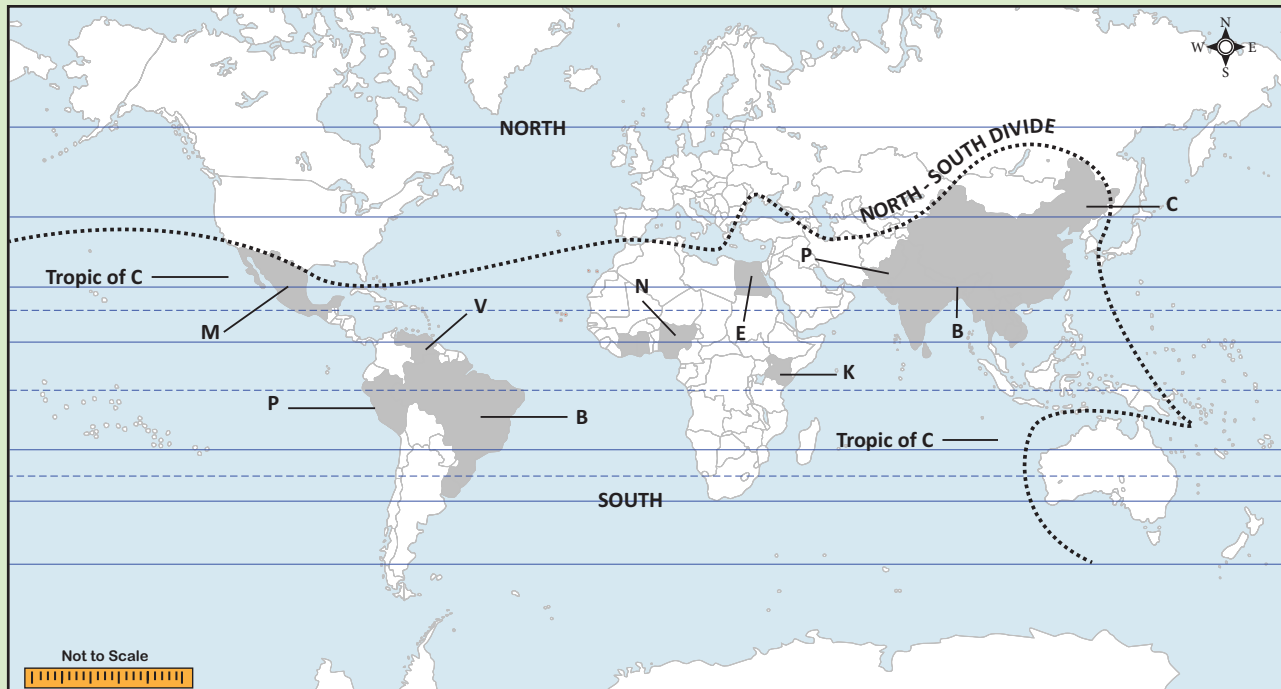

d) Which four of the statements are correct about the developing countries?

1. All of them lie south of North-South divide.
2. The all lie south of the Equator.
3. Most of them lie within the tropics.
4. They all lie in South America, Asia and Australia.
5. None are found in Europe and North America.
6. They all lie in South America, Asia and Africa.



Reference

1. Economic and commercial geography, K.K. Khanna and Dr. V.K Gupta
2. Human and economic Geography, Goh Cheng Leong and Gillian C. Morgan



Web reference

1. <https://www.un.org/development/desa/dpad/>
2. www.weforum.org/agenda/2017/03/worlds-biggest-economies-in-2017/



ICT CORNER

Economic Activities- Farming

This activity enables the students to understand about the FARMS and how to do the farming. And also know a little bit about sales and profit



Steps

- Type the URL link given below in the browser or scan the QR code. A page opens go down and click “FARM MANIA”. Skip the add
- Now another page opens with menu.
- Select Play and start to play according to the instructions.
- End you will get your own farm.

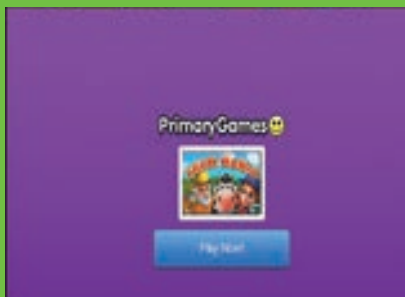

Step 1



Step 2



Step 3

Website URL:

<http://www.primarygames.com/arcade/simulation/farmmania/>

*Pictures are indicative only.



UNIT 5

Cultural and Political Geography



Unit Overview

- 5.1 Introduction
- 5.2 Cultural Realms of the World
- 5.3 Races
- 5.4 Tribal Distribution of the World
- 5.5 Political Geography - Concept of Nation and State
 - 5.5.1 Frontiers and Boundaries
 - 5.5.2 Geopolitics: Global Strategic views
 - 5.5.3 21st Century Geopolitics of the Multipolar World Order

5.1. Introduction

An interesting traditional Chinese custom says that a husband should carry his bride over a pan of burning coals before crossing the threshold of their home as husband and wife. According to tradition, the ritual ensures that the wife will have an easy and successful labour. Fire walking is also performed by some Chinese people as a means to prevent natural disaster’.

‘In Cypriot culture, do not give white lilies as they are used at funerals. It is polite to finish everything on your plate. If you have not finished eating, cross your knife and fork on your plate with the fork over the knife’. It indicates you have finished eating by laying your knife and fork parallel across the right side of your plate’. Do you know some interesting custom practiced in our culture?

Learning Objectives

- *Understand the existence of cultural diversity and cultural traits around the world.*
- *Describe the world distribution of the tribes.*
- *Explain the concept of nation and state.*
- *Distinguish between Boundaries and Frontiers*
- *Understand political relevance of Heartland theory and Rimland theory to the present world.*



Culture is the total way of life that characterises a group of people. There are thousands of cultures existing today and each contributes to global diversity. There are so many ways that people can be culturally different. Specifically, a culture consists of numerous cultural components that vary from one culture group to the other. Some of the cultural parameters are religion, language, architecture, cuisine, technology, music, dress, gender roles, law, education, government, agriculture, economy, sport, values, and many more.

Culture Region

A culture region is a portion of Earth that has common cultural elements and has distinct cultural authority from other regions. Any number of cultural components may be used to define culture regions. A map of world religions, for example, includes a shaded area in South Asia where Hinduism is dominant.

Culture regions differ greatly in size. Some are exceedingly large, like the Islamic culture region that encompasses millions of square km of North Africa and Southwest Asia. Some are very small, like Spanish Harlem, which encompasses about three square km of Manhattan. Many others are of intermediate size, like the Corn Belt, which occupies a portion of the mid western United States.

Cultural Diffusion

Cultural diffusion is the spread of cultural beliefs and social activities from one group of people to another. Mixing of world culture through different ethnicities, religions and nationalities has only increased with advanced communication, transport and technology.

Cultural Landscape

Cultural Landscapes have been defined by the World Heritage Committee as “cultural properties representing the combined works of nature and of man”.

The World Heritage Committee has identified and adopted three categories of cultural landscape. The three categories extracted from the Committee’s Operational Guidelines, are as follows:

- (i) “A landscape designed and created intentionally by man”.
- (ii) An “organically evolved landscape” which may be a “relict (or fossil) landscape” or a “continuing landscape”;

- (iii) An “associative cultural landscape” which may be valued because of the “religious, artistic or cultural associations of the natural element”.

Cultural Interaction

Cultural interaction focuses on the relationships that often exist between cultural components that characterize a given community. Different factors interact with each other and give rise to prevalent trait.

What language do you speak? What dress do you wear? What food do you like? What is the structure of the house you live in? For the above question by searching the answer we can learn the culture of a human society.

Culture shapes our identity and influences our behaviours. Culture refers to the sharing language, beliefs, values, norms, behaviours and material objects, which are passed from one generation to the next generation. Cultural geography is the branch of human geography which deals about the areal organization of various cultural aspects in relation to total environment. Some of the cultural aspects are as follows:

Language

Language plays great force in socialization and historical transmission, which is the primary instrument for transmitting culture. Human can bind any group of people through the network of interaction. Languages are in written or oral form. India (780) has the world’s second highest number of languages, after Papua New Guinea (839).

Customs

Custom in law is the established pattern of behavior that can be objectively verified within a particular social setting. Habit is a similar word which is adopted by an individual and it has been adopted by most of the people of the ethnic group or society.

Norms

Norms refers to attitude and behaviours that are considered normal, typical or average within the group. Cultural norms are the standards we live by. They are the shared expectations and rules that guide behaviour of people within social groups. Cultural norms are learned and reinforced from parents, friends, teachers and others while growing up in a society. Norms often differ across cultures, contributing to cross-cultural misunderstandings.

Values

Values refer to intangible quality or beliefs accepted and endorsed by a society. A culture's values are its ideas about what is good, right, fair, and just. Sociologists disagree, however, on how to conceptualize values. Conflict theory focuses on how values differ between groups within a culture, while functionalism focuses on the shared values within a culture.

Cultural Heritage

Cultural Heritage is an expression of the ways of living developed by a community and passed on from generation to generation, including customs, practices, places, objects, artistic expressions and values. Cultural Heritage is often expressed as either Intangible or Tangible Cultural Heritage. As part of human activity Cultural Heritage produces tangible representations of the value systems, beliefs, traditions and lifestyles. As an essential part of culture as a whole, Cultural Heritage, contains these visible and tangible traces from antiquity to the recent past.

Cultural Heritage types

Cultural Heritage can be distinguished in: Built Environment (Buildings, Townscapes,

and Archaeological remains), Natural Environment (Rural landscapes, Coasts and shorelines, agricultural heritage) and Artefacts (Books & Documents, Objects, and Pictures).

Cultural diversity

Cultural diversity refers to having different cultures, respect to each other differences. Cultural diversity is important; because of work place and show increasingly consist of various cultural, racial and ethnic groups. We can learn from one another but first we must have a level of understanding. Cultural diversity exists in many countries around the world, but it can be challenging and, at times, problematic. Through this lesson, you will learn how to define cultural diversity and explore some of the ways in which it influences society.

Cultural Traits

A cultural trait is a characteristic of human action that's acquired by people socially and transmitted via various modes of communication. Cultural traits are things that allow for a part of one culture to be transmitted to another. There are millions of culture traits, a trait can be an object, a technique, a belief or an attitude. Culture traits are interrelated with each other, their collective function forms culture complex.

5.2 Cultural Realms of the World

Cultural realm refers to a type of cultural region. Cultural region is a continuous geographical area characterized by cultural homogeneity. It may be classified into three categories as macro, meso and micro region. Cultural realm is classified based on the attitude, religious belief, language, racial group, technological development, etc. There are twelve Cultural realms in the modern world. Let us discuss some of them briefly.

Occidental Realm

Occidental culture is the culture of the European society. It is influenced, to a great extent, by Christianity. It has regional modifications on the basis of varying levels of industrialisation, political and economic thought, colonisation, commercialisation, urbanisation, and development of transport system, land development of social, political and economic institutions.

In many parts of the occidental culture, the impact of non-religious factors, particularly the effect of modernisation, is so great that the religious values are sidelined. Post- industrial Europe is fast emerging as a society where traditional values are nearly abandoned. The occidental culture covers a vast area. It is further divided into six sub-regions considering the impact of regional environment.

- (I) West European is the most industrialised and urbanised culture.
- (ii) Continental European culture is influenced by different political and economic thoughts, while Christianity remains an important influence.
- (iii) Mediterranean Europe includes countries lying to the south of the Alps. It is the region of dominance of Christianity.
- (iv) Anglo-American and
- (v) Australian cultural realms are practically the offspring's of west European culture. Both are inhabited by migrants from west Europe. There are only some regional differences.
- (vi) Latin American culture is very similar to the Mediterranean culture. It is the only region of occidental culture which lies in the tropics and is underdeveloped. It became a

part of the occidental culture as a result of conversion of tribes into Christianity. The colonial languages, Spanish and Portuguese, have become the state languages. Regional architecture has been influenced by the Spanish and Portuguese styles. Practically all countries maintain economic, cultural and social ties with the Mediterranean countries.

Islamic Cultural Realm

The Islamic Cultural Realm is influenced by Islamic values. It covers a vast geographical area from Morocco in the west to Pakistan in the east. The population is sparsely distributed due to inhospitable environment. The coasts, river basins and oases have been the cradles of Arabian culture in this realm. The British call it the Middle-East while the Germans call it a region of oriental culture. This cultural realm lies between the traditional Indian culture in the east and the modernised European culture in the west.

Islamic culture is highly orthodox and based on traditional beliefs, the impact of which can be seen in high female illiteracy rates. These countries have very high per capita incomes, but the level of modernisation is very low.

Indie Cultural Realm

Indie Cultural Realm is the culture of the Indian sub-continent. Baker called it a sub-continental culture, while D. Stamp used the term paddy culture. This cultural realm is well-defined; it lies between Himalayas in the north, Indian Ocean in the south and Hindukush Mountains in the west.

This cultural realm is characterized by joint family, village community, caste system, semi-feudal land relations, subsistence agriculture, paddy farming, seasonal climate changes and agricultural season coming at the same time all over the region. The culture of this region is

greatly influenced by Vedic values. Though the region is inhabited by various communities, the social system has the hidden impact of Vedic cultural values.

East Asian Culture

This culture is basically a Buddhist culture with regional modifications. True Buddhist culture can be seen in South Korea and Japan. Even these two countries have felt the impact of industrialisation, urbanisation and modernisation. The culture of mainland China has modified the Buddhist system. This culture was adopted after the Second World War.

South-East Asian Culture

It is a transitional culture lying at a place where different cultures have intermingled. Dominance of Buddhism can be seen in Myanmar, Thailand and Vietnam. Influence of Christianity can be seen in the Philippines and of Indie culture over islands of Indonesia. The Islamic influence is evident in Malaysia and the Indonesian islands. No other region has such peculiarities.

Meso-African Culture

This culture is also known as the Negro culture. It principally includes tropical Africa. Similar cultural systems can be seen among the American Red Indians, Latin American tribes, Australian aboriginals and several tribes of Asia-Pacific region.

Historian Toynbee has used the term 'marginalised culture' for these traditional culture units. Some geographers even include Eskimos under this cultural realm. Thus, it is a widely scattered cultural realm characterised by marginalised and relatively isolated communities.

Major Culture Hearths

Areas from which important culture traits, including ideas, technology, and social structures, are originated.

Folk Culture

Culture traits that are traditional, no longer widely practiced by a large number of people, and generally isolated in small, often rural, areas.

5.3 Races

The race is a group of people with more or less permanent distinguishing characteristics. There are skin colour and hair colour to which persons concerned attach certain interpretations. Objectives and scientific classification are the division of mankind into racial groups should be done on the basis of measurable physical features and qualities inherited from a common ancestor. The important features on the basis of which the races are identified and classified include skin colour, stature, shape of head, face, nose, eye, type of hair, and blood group. Human races are classified into four broad groups:

1. Negroid, 2. Caucasoid, 3. Mongoloid and 4. Australoid.

HOTS

If human being originated from one point, Africa and spread to rest of the world, how could they become different races?

1. The Negroid

They are usually called as "black race". They have the darkest skin tone than other races, and other common characteristics are the sloped forehead, thick lips, wide nose, and dark hairs. They are living in Sub-Sahara Africa.

2. The Mongoloid

They have the folding eye lids, almond shaped eyes, yellowish skin tone, and V shaped cheeks. Native Americans and Eskimo are also classified as Mongoloid. Compared to the other races, they have the least body hair, least body odour, and smallest limb ratio. Their facial structure is likely to adapt cold mild wind. They are living in East Asia.

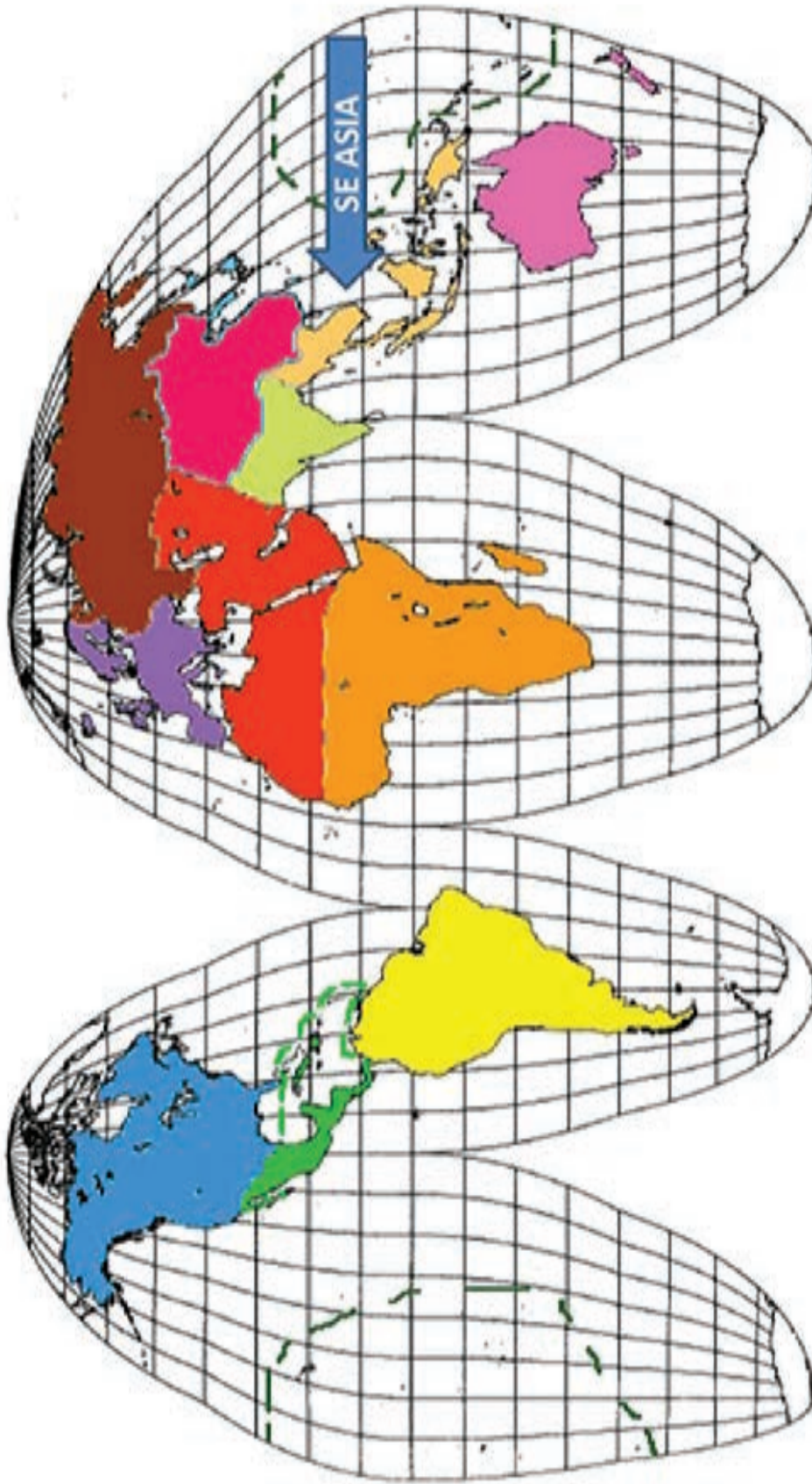

- | | | | |
|--|--|--|---|
|  North America |  Europe |  Russia |  Southeast Asia |
|  Middle America |  North Africa-SW Asia |  East Asia |  Australia-New Zealand |
|  South America |  Subsaharan Africa |  South Asia |  Oceania-Pacific |

CULTURAL REALMS OF THE WORLD

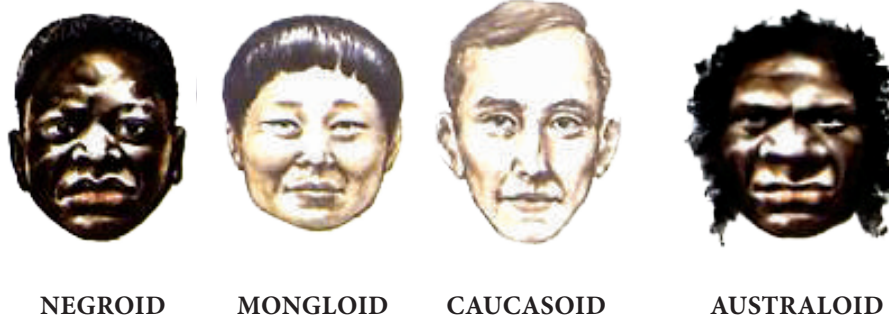

NEGROID

MONGLOID

CAUCASOID

AUSTRALOID

3. The Caucasoid

The Caucasoid is known as "white people" characterised by the pointy nose, vertical forehead, pinkish/orange skin tone, visible brow ridge, and colourful eyes/hair. Some believe that their light skin tone is meant to receive more sunlight due to Europe's climate. Some believe that their nose structure is meant to keep the

nose moisture from getting dried by the wind. They are living in Europe and Middle East.

4. Australoid Race

They have visible eye ridge, wide nose, curly hair, dark skin tone, and short in height. Some believe that their visible thick lips helps them to eat stiff foods. They are living in Australia and Papua New Guinea.

Characteristic of Major Races

Feature	Caucasoid	Mongoloid	Negroid
Skin colour	Pale reddish white to olive brown.	Saffron to Yellow Brown, reddish brown.	Brown to black brown yellow brown.
Stature	Medium to Tall.	Medium tall to Medium Short.	Tall to very Short.
Face	Narrow to medium broad, tends to high no prognathism	Medium broad to very broad malars high and flat tends to medium high	Medium broad to narrow tends to medium high strong prognathism
Head Form	Long-broad and Short Medium, high-very high.	Medium height, predominantly broad.	Predominantly long, Low height.
Hair color	Light blonde to Dark brown, straight to wavy.	Brown to brown black, Straight.	Brown black light curl and wooly.
Body Build	Linear to lateral slender to refuge.	Tend to be lateral, some linearity evident.	Tend to be linear and muscular.
Nose	Usually high, narrow to medium broad.	Low to medium form, medium broad.	Low, medium to very broad.
Blood Group	More A than B.	High in B.	High is Rh(D).
Eye	Colour: light blue to dark brown , lateral eye - fold occasional	Colour: brown to dark brown , medial epicanthic fold very common	Colour: brown to brown black, vertical eye - fold common

Ethnicity

Ethnicity is a concept referring to a shared culture and a way of life. This can be reflected in language, religion, material culture such as clothing and cuisine, and cultural products such as music and art. Ethnicity is often a major source of social cohesion and social conflict. The world is home to thousands of different ethnic groups, from the Han Chinese (the largest ethnic group in the world) to the smallest indigenous groups, some of which include only a few dozen people. Almost all of these groups possess a shared history, language, religion, and culture, which provide group members with a common identity.

India is a unique country with great diversity in ethnicities, race, religion, language, culture, cuisine and in every other aspect of the human society. Indian civilization is one of the oldest in the world and primarily consists of the Indo-Aryans of North India and the Dravidians of South India, the people of the Indus Valley Civilization while the former migrated to the country at about 1800 BC. As India has such a diverse cultural demographic, it makes sense that the country is also.

Dravidians

The Dravidian people are any native speakers of the Dravidian languages in the Indian Subcontinent. Almost all the Dravidians live in the southern part of India. The five major ethnic groups of Dravidian people in India are Tamil, Telugu, Kannada, Malayalam, and Tulu.

The ancient Indus Valley civilization in India was believed to have been of Dravidian origin in northern India, but then the Dravidian people were pushed south when the Indo-Aryans came in and the Kuru Kingdom in northern India arose. Later South India was dominated by the three Dravidian kingdoms of the Cheras, Cholas, and the Pandyas. These three kingdoms have been shown to sponsor the growth of literature, music, and the arts and to have done extensive trading. The three

kingdoms also supported and were tolerant of Buddhism, Jainism, and Hinduism. The major languages spoken by the Dravidian people are Tamil, Telugu, Kannada, Malayalam, and Brahui.



Arabic script Brahui is the only Dravidian language which is not known to have been written in a Brahmi based script, instead, it has been written in the Arabic script since the second half of the 20th century in Iran Pakistan and Afghanistan.

Religion

Religion is not a vague fear or unknown powers not the child of terror, but rather a relation of all the members of a community to a power that has the good of the community at heart and protects its law and moral order. Religion produces a distinct attitude towards life which affects the further development of the society. Indeed most cultural situations show the mutual interaction between religion and socio-economic and politico-cultural factors.

Classification of religion

Religion may be classified based on the belief in god. Monotheistic: the followers of monotheism believe in a single god (Islam, Christianity). Polytheistic: the followers of polytheism believe in many gods (Hinduism). Another classification is on the basis of areas of origin such as Eastern religion, Western religion, far Eastern religion, African religion, Indian religion, etc. Geographers generally classify religions into following;

- Universalizing religions – Christianity, Islam, Buddhism.
- Ethnic religions – Hinduism, Shintoism (Japan), Chinese faiths, Judaism.
- Tribal or traditional religions – animism, shamanism, secular (non religious and atheists).

Major religions of the world

Major religions of the world are classified based on the followers. They are Christianity, Islam, Hinduism, Buddhism, and Judaism. Other important religions include Chinese folk religions, Sikhism, Confucianism, Shintoism etc.,

Christianity is a universal religion which has the largest number of followers in the world. They are spread in Europe, Anglo America, Latin America, Africa, Asia and Oceania. Its sacred book is "Bible". Islam is the second largest religion of the world. The largest concentration of the Islam is in the South West Asia, Central Asia, South Asia and South East Asia Followed by the North Africa. Shia and Sunni are its two main sects. Its sacred book is Kuran.

Hinduism is the oldest ethnic religion of the world which was founded about 3000 B.C (B.C.E) in India. Today it has over 8 million followers in the world but main concentration is in India and Nepal. Nearly 99 percent of the total Hindu population is concentrated in south Asia. Its sacred book is Bhagavad Gita. Buddhism is also one of the oldest religions of India which was founded by Lord Buddha around 525 B.C (B.C.E). Its spread in several Asian countries (China, Myanmar, India, Srilanka, Japan, Mongolia, Korea and South East Asian countries) due to its liberal philosophy. Its two main sects are Hinayana and Mahayana.

Judaism is the oldest Monotheistic faith which is regarded as the parent of Christianity. It originates 4000 years ago in the Middle East. At present it has about 14 million followers living in U.S.A, Europe and Asia. Chinese religions include two main beliefs called Confucianism and tao-ism. Confucianism was established by Confucius (551-479 B.C (BCE)). Taoism was established by Lao Tse (604-517 B.C (BCE)).

Jainism is also born in India as a reaction to orthodox Hinduism. It was founded by Lord

Mahavir who was a Contemporary of Lord Buddha. Its followers are mostly concentrated in India. It is an offshoot of Hinduism which was established in the 15th century by Guru Nanak. It remained confined to Punjab state and has accepted Gurumukhi as its language.

Tribal Religions

Tribal religions are the special forms of ethnic religion. The tribal people are generally in the Neolithic stage of social development. Tribal people are strikingly different and diverse in their culture, social and economic life. They cherish their own distinct and have maintained a close relationship to the land and natural environment. Most of them live according to their traditions and are engaged in food gathering, hunting, fishing, primitive agriculture etc, there are about 300 million indigenous people worldwide, constituting about four percent of the total population of the world living in more than sixty countries.



The percentage of tribal to total population is as high as over 90 percent in Greenland, 66 percent in Bolivia and 40 percent in Peru. In India share of tribal people to total population is 8.2 percent.

Sometimes the tribal people are being termed as the fourth world. The first – second and third world believed that “the land belongs to the people” whereas the fourth world believes that “the people belongs to the land”.

5.4 Tribal Distribution in world

Some major tribal group of the world particularly who are living and struggling

1. Equatorial Forest region: Pigmy, Semang, Sakai, Boro, Papuan, etc.
2. Grasslands: Masai, Kyrghiz, etc.
3. Tropical deserts: Bedowin, Bushman, Aborigines etc.

4. Mountainous region: Bhotia, gujjar, Naga etc.
5. Monsoon regions: Gonds, Santhals, Todas, Bhils, etc.
6. Arctic cold regions: Eskimo, Lapp, Alute, Chukchi etc.



Pigmies

The pigmies are Negroid people and are also called Negrillos. They are short stature, flat nosed, woolly haired, long headed and black people. The average height of men and women are found 150cm. So they are also called dwarf. The pigmies are those who live in scattered parts of tropical Central Africa. They are found in many sub-groups in the equatorial forest region of Africa mainly in Congo basin 3°N and 3°S latitudes along both sides of the equator. In addition some groups of Pigmies are also found in the forests of Philippines and New Guinea.

Masai



The Masai of east Africa belong to the pastoral society and are known as the best and most typical cattle herders not only of Africa but also of the world. Masai people are tall and

slender with long feet, hands and fingers. Their skin colour ranges from light chocolate to dark brown. They have high and long head, thin face and nose. Their lips are less thick than that of Negroid people. Masai occupy the interior plateau of the equatorial Africa. The territory of the Masai lies between 1°N and 6°S latitudes and covers all the rift valleys in this region.



Bedouin

In Arabic, Bedouin means desert dwellers. The Bedouins are most important among the tribal of South West-Asia and North Africa. They are pastoral nomads and keep camel, sheep, goats, horse etc. The Bedouins occupy the desert areas of the Arabian Peninsula including Saudi Arabia, Yemen, Oman, Syria and Jordan. The Bedouins belongs to the mixture of Mediterranean and Armenian races. They are medium stature people with long narrow face, prominent nose, dark eyes and hair. Their complexion is wheatish to pale.

Bushman

Bushman is the tribal people of Kalahari Desert in southern Africa who are still engaged in hunting and gathering economics. They are on constant run for both food and water. Their homeland Kalahari Desert lies in Botswana, Namibia and southern Angola. The bushman territory is a wide plateau about 2000 meters above the sea level with sub tropical climate. The bushman are included in the Negroid stock. They are very short in stature and have



long head, short and flat ears, and yellowish brown complexion. On the whole the Negroid characteristics prevail among the Bushman.

Eskimos

Eskimos also called Inuits are tribes of tundra cold region in Canadian northland, Alaska, Greenland and north-eastern Siberian coastal region. The Eskimos are Mongoloid race. The main physical characteristics of the Eskimos are short stature, Flat narrow face, small snub nose, yellow –brown complexion and coarse straight black hair. Hunting and fishing are the main occupations of the Eskimos. They live in igloo and practice hunting way known as Maupak. The Eskimos wear clothes of caribous or reindeers skin and other furs.



Igloo



Sledge

Eskimos are migratory by nature and construct ice houses called Igloos. For travelling on ice shield the Eskimos use sledge which is usually built either of whale bone or of wood whichever is available. It is drawn by two or more dogs, caribous or reindeer.

Tribal in India

India is the home to large number of indigenous people, who are still untouched by the lifestyle of the modern world. With more than 84.4 million, India has the largest population of the tribal people in the world. These tribal people also known as the adivasis are the poorest in the country, which are still dependent on hunting, agriculture and fishing. Some of the major tribal groups in India include Gonds, Santhals, Khasis, Angamis, Bhils, Bhutias and Great Andamanese. All these tribal people have their own culture, tradition, language and lifestyle. There are more than 50 tribal groups in India. Most of the tribal belong basically to the Negroid , Australoid and Mongoloid racial stocks.

Bhils

Bhils are popularly known as the bow men of Rajasthan. They are the most widely distributed tribal groups in India. They form the largest tribe of the whole South Asia. Bhils are mainly divided into two main groups the central or pure bills and eastern or Rajput Bhils.

Gonds

The Gonds are the tribal community mostly found in the Gond forests of the central India. They are one of the largest tribal groups in the world. Gonds have been largely influenced by the Hindus and for the long time have been practicing the Hindu culture and traditions.

Santhals

Santhals are the third largest tribe in India. They are mostly found in the states of West Bengal, Bihar, Odisha, Jharkhand and Assam. They belong to the pre- Aryan period and have been the great fighters from the time of the British.

Munda

Munda tribe mainly inhabit in the region of Jharkhand, although they are well spread in the states of West Bengal, Chhattisgarh, Odisha and Bihar. Munda generally means headman of the village. Hunting is the main occupation of the Mundas tribe.

Khasi

Khasi tribe is mainly found in the Khasi Jaintia hills in Meghalaya and in the states of Punjab, Uttar Pradesh, Manipur, West Bengal and Jammu and Kashmir. They form the large part of the population in the state of Meghalaya.

Angami

Angami tribe belongs to the extreme north eastern part of the country, in the state of Nagaland. The total population of the Angamis is around 12 million. They are quite popular for their woodcraft and artwork. Sekrenyi is the

main festival celebrated among the Angamis in Nagaland

Bhutia

Bhutia tribes are of the Tibetan origin. They migrated to Sikkim around 16th century. In the northern part of the Sikkim they are known as the Lachenpass and Lachungpass. Bhutias forms 14% of the total population of Sikkim. Losar and Losoong are the main festivals celebrated among the Bhutia tribes.

CASE STUDY

The Sentinelese tribe, the most dangerous tribe in the world!



Located far into Andaman and Nicobar Islands, the Bay of Bengal in the Indian Ocean, North Sentinel Island is one of the most isolated places on earth. This remote island is home to the Sentinelese tribe, the most dangerous tribe in the world. The Sentinelese are hunter-gatherers, as agriculture is not known to them. Their diet consists mainly of coconuts and fish that can be found in the shallow waters around their shores. The Sentinelese would be described as Stone Age people. The women wear fibre strings tied around their waists, necks and heads. The men also wear necklaces and headbands, but with a thicker waist belt. The men carry spears, bows and arrows. Sometimes the Sentinelese appeared to make friendly gestures at others they would take the gifts into the forest and then fire arrows at the contact party. The population of North Sentinel Island is estimated at 250 individuals. The Sentinelese do not want help from outsiders.

Chenchu

Chenchu inhabit in the Nallamalai hills, which have been the part of the Nagarjuna Sagar Tiger Sanctuary for centuries in Andhra Pradesh, India. They are mainly found in the districts of Mahabubnagar, Nalgonda, Praksham, Guntur, and Kurnool.

Great Andamanese

Great Andamanese is the Negroid tribe inhabitant in the Andaman group of Islands. They form the largest population among the other tribes found in these islands. According to the census the population of Great Andamanese is now limited to few individuals.

Tribals in Tamilnadu

Tribes of Tamil Nadu are concentrated mainly in the district of Nilgiris. Of all the distinct tribes, the Kodas, the Thodas, the Irulas, the Kurumbas and the Badagas form the larger groups, who mainly had a pastoral existence. Other tribes include, Kattunayakan and Paliyan.

According to census 2011, tribal population in Tamil Nadu is 7, 94,697. There are around 38 tribes and sub-tribes group in Tamil Nadu. The tribal people are predominantly farmers and they are much dependant on the forest lands.

Toda: Men from the family of the tribes are occupied in milking and grazing their large herds of buffaloes. Their settlements are known as 'Munds'. They do not worship any god and their consciousness is cosmic. They live in Nilgiris. Today, there are about a thousand Todas left.

Badaga: The Badagas belong to the backward class and are not classified as tribal. They are an agricultural community, dwelling in the higher plateau of the Nilgiris district in the state of Tamil Nadu. They are engaged in tea cultivation and potato growing. They form the largest group of tribes and boast a rich oral

tradition of Folk tales, songs and poetry. These tribes are Hindu and belong to the shiva sect.

Kota: The Kotas are mainly concentrated in the Tiruchigadi area in the Nilagiri hills. They are distinguished by their colourful Folk dances and are basically musicians, who play at Badaa funerals. They are mainly engaged in producing handicrafts. These tribes of Tamil Nadu are expert iron smiths, potters and carpenters. In order to maintain distance and status in society, the Kotas implement elaborate tattoos.

Kurumbas: The Kurumbas tribes of this state inhabit the intermediate valleys and forests in Villages and were known for their black magic and witchcraft in the past. Their way of living today has changed from their original gathering and hunting existence to working in Coffee and Tea plantations as labourers. Kurumbas are perhaps the only main caste in southern India that has a specialized and distinctive Kurumbas Language.

Irula: The Irula tribes of Tamil Nadu occupy the lower slopes and forests at the base of the Nilgiri Hills. They constitute the second largest group of tribes after the Badagas and are similar to the Kurumbas in many ways. This tribe produces honey, fruits, herbs, roots, gum, dyes etc., and trades them with the people in the plains. In the recent times the Irulas help in catching snakes and collect the snake venom.

Paliyan: They are of the food gathering communities of Tamil Nadu. It is believed that the Paliyan originally belonged to the Palani hills. They are distributed in the districts of Madurai, Tanjavour, Pudukkottai, Tirunelveli and Coimbatore.

Language

Language is an identification mark for different cultures. Because language is essential to communication, it strongly influences the sort of political, social and economic we

create. As a result, economic and religious system frequently follows patterns of language distribution and political borders quite often parallel linguistic boundaries. In modern times linguistic diffusion has been facilitated by trade, tourism, media and international organizations. It has helped in the development of the linguistic pluralism. The greatest linguistic diversity is attributed to heterogeneous societies.



Tamil is one of the longest-surviving classical languages in the world. The earliest period of Tamil literature, Sangam literature, is dated from 300 BC (BCE) – AD (CE) 300. It has the oldest extant literature among Dravidian languages.

Major linguistic Families of the World

The classification of languages by origin and historical development is known as a genetic classification. The languages which are the descendants of common ancestral language are called proto – language.

G.L. Trage has classified the languages of the world into 7 linguistic phylum and 30 linguistic families. Linguistic families are further classified in to sub families of languages, which denote major languages.

1. Indo-European - a. Indo-Iranian, b. Latin or Romantic, c. Germanic, d. Balto –Slavic, e. Celtic, f. Hellenic
2. Sino-Tibetan - a. Chinese, b. Tibetan, c. Burman
3. Afro-Asiatic – a. Semitic, b. Egyptian, c. Cushitic, d. Chadic
4. African – a. Niger – Congo (Atlantic, Voltaic, Benu-Nagar)
b. Sudanic (Chari-Nile, Saharan),
c. Click Languages (Khoisan)
5. Ural-Altai - a. Finno-Igric, b. Turkic, c. Mangolic, d. Tunguzic

6. Dravidian- malayo – Polynesian- -
a. Dravidian, b. Malayan, c. Melanesian,
d. Micronesian, e. Polynesian, f. Austro-Asiatic.
7. Palaeo Asiatic- a. Yukaghir



As many as half of the world's 7,000 languages are expected to be extinct by the end of this century; it is estimated that one language dies out every 14 days.

Major Languages of India

India has a rich Linguistic heritage and has heterogeneous ethnic and social groups, which have their own languages and dialects. According to census of India 1961, there were 187 languages spoken by various sections of Indian society. 23 major languages were spoken by about 97 percent population of the country. 22 languages excluding English are mentioned in the eighth schedule of the constitution of India as follows; Kashmiri, Punjabi, Hindi, Urdu, Bengali, Assamese, Gujarati, Marathi, Kannada, Tamil, Telugu, Malayalam, Sindhi, Sanskrit, Oriya, Nepali, Kongani, Manipuri, Bodo, Dogri, Maithili and Santali of these languages, 14 were initially included in the Constitution. Subsequently, Sindhi was added in 1967 by 21st constitutional amendment act; Konkani, Manipuri and Nepali were added in 1992 by 71st Constitutional Amendment Act; and Bodo, Dogri, Maithili and Santali were added in 2003 by 92nd Constitutional Amendment Act. Indian Languages belong mainly to four linguistic families

1. Austric – Munda, Mon-Khmer
2. Dravidan – Tamil, Telugu, Kannada, Malayalam, Gondi, kurukh, orean, etc.
3. Sino- Tibetan- Bodo, Karen, Manipuri, etc.
4. Indo - Aryan – Hindi, Urdu, Sans.

Dialect

A distinct linguistic form peculiar to a region or social group but which nevertheless, can be understood by speakers of other forms of the same language. The two main types of dialects are the **geographic dialect**, spoken by the people of the same area or locality, and the **social dialect** used by people of the same social class, educational level or occupational group.

Major dialects in India

More than 40 languages or dialects in India are considered to be endangered and are believed to be heading towards extinction as only a few thousand people speak them officials said.

According to a report of the census Directorate, there are 22 scheduled languages and 100 non –scheduled languages in India. The scheduled languages are 11 from Andaman and Nicobar, Seven from Manipur and Four from Himachal Pradesh. There are 42 languages spoken by less than 10,000 people. Some other languages also are in endangered position in India.

Major dialects in Tamil Nadu

Tamil is an interesting language with a range of native dialects. The language has several charming improvisations in different regions of

the state. Many people are familiar with the old and familiar dialects of Tamil such as Chennai, Coimbatore, Madurai and Tirunelveli.

5.5 Political Geography - Concept of Nation and State

Nation

A nation is a group of people who see themselves as a cohesive and coherent unit based on shared cultural or historical criteria. Nations are socially constructed units, not given by nature. Their existence, definition, and members can change dramatically based on circumstances. Nations in some ways can be thought of as “imagined communities” that are bound together by notions of unity that can pivot around religion, ethnic identity, language, cultural practice and so forth.

State

A State is an independent, sovereign region and its government exercise control over certain spatially defined and bounded area, whose borders are usually clearly defined and internationally recognized by other states.



Vaishali was established as a republic by the 6th century B.C (BCE), prior to the birth of Gautama Buddha in 563 B.C (BCE), making it the world's first republic.

Fact File

UNESCO'S five levels of language risk:

Safe: Widely spoken

Vulnerable: Not spoken by children outside the home (600 languages)

Definitely endangered: Children not speaking (646 languages)

Severely endangered: Only spoken by oldest generations (527 languages)

Critically endangered: Spoken by only a few members of the oldest generation, often semi-speakers (577 languages)

Nation-State

The nation state is a system of organization defined by geography, politics and culture. The nation is cultural identity that is shared by the people, and the state is the governing administration. A nation state must have a shared national identity, physical borders, and a single government.

A nation-state is a political unit with a well-defined territory, inhabited by a people who are well-organised, possess sufficient powers and

consider themselves to be a nation by virtue of certain binding factors which may be emotional and which are reflected in law and governance.

5.5.1 Frontiers and Boundaries

Frontiers: International frontiers and boundaries separate land, rivers and lakes subject to different sovereignties. In 1900 frontiers had almost disappeared and had been replaced by boundaries that are lines. A Frontier is a politico geographical area, lying beyond defined borders of a political unit into which expansion could take place

Different between Frontier and Boundary

Frontier	Boundary
1. Natural	1. Mostly Anthropogenic
2. Areal Concept	2. Linear Concept
3. Frontiers have no political dispute	3. Boundaries vary often disputable by the rival nations
4. Frontier generally has mountainous area, desert, marshes, etc. Thus, inhabitable	4. But boundaries have no such criteria
5. Frontiers are dynamic	5. Boundaries are static because once fixed, they hardly change

Boundaries: A boundary is a line demarcating the recognised limit of an established political unit, administrative region or geographical region e. g a state, country or district.



China has the maximum number of neighbours touching its border. The 14 countries touching its border are: India, Pakistan, Afghanistan, Tajikistan, Kyrgyzstan, Kazakhstan, Mongolia, Russia, North Korea, Vietnam, Laos, Myanmar, Bhutan and Nepal



Canada, the world's second largest country, shares the longest international land border with the United States. The Canada-US land border is 8,893 km long.

Types of Boundaries

Boundaries can be classified according to their relationship with the cultural landscape. Some boundaries were established prior to the permanent occupation of areas by the present inhabitants. In some cases patterns of settlement were already developing so that the boundary ultimately established has a different relationship to the cultural realities of the area involved. This classification is known as the functional or genetic classification of boundaries.

Genetic Classification of the boundaries

1. Antecedent Boundaries

The boundaries drawn before the cultural-political realm.

Such boundaries were non-contentious.

E.g, N. Africa and the state boundaries of USA.

2. The Subsequent Boundaries

When the cultural realms are fully developed & political boundaries are contentious.

Such boundaries are irregular or amorphous boundaries.

E.g. the countries of Europe.

3. Superimposed Boundaries

When a political boundary divides a homogenous cultural region and across the

boundary the people with similar ethnicity are found.

E.g. Pakistan occupied Kashmir

4. Relict Boundaries

Historical boundaries which only exist in the books.

E.g. Persia, the boundary between east & West Germany.

5.5.2 Geopolitics: Global Strategic views

The study of the way a country's size, position, etc, influence its power and its relationships with other countries. Political activity is influenced by the physical features of a country or area of the world. Geo politics is concerned with how geographical factors including territory, population, strategic location, and natural resources endowments as modified by economics and technology affect the relations between states and the struggle forward domination. It is battle between land power and sea power which is going to lead the world continents by one.

Mackinder described the political history of the world as continuous struggle between land and sea powers. According to him, the Columbian era of sea powers, which gave Europe its pivotal position for four centuries is coming to an end. And in the struggle between land and sea powers, the ultimate victory is going to be of one possessing land powers. He divided the earth into 3 tiers.

1) The Heartland - area of interior and Arctic drainage in the Eastern Europe, covered by mountains on three sides and Arctic in north. This is a natural fortress on earth, inaccessible to sea powers.

2) The Inner or Marginal Crescent - area of Europe and Asia adjoining the Heartland and Africa, north of Sahara.

3) The Outer or Insular Crescent - It includes North and South America, Africa (south of Sahara) and Australia. Besides, it also includes the Great Britain and Japan because of their insularity from Eurasia.

According to Mackinder, one with control over Heartland will be in an unstoppable position to rule the world. Heartland, with its agricultural and industrial resources would conquer the inner crescent and Outer crescent would follow later. He conceptualized his theory as:

Who rules East Europe commands the Heartland.

Who rules Heartland commands World Island.

Who rules World Island commands the World.

Mackinder later argued that key to control Heartland lays in Eastern Europe, reflecting a powerful strand of pre and post- Versailles geographical thinking concerning the news to separate the powerful states of Germany and Russia by the creation of 'buffer states'.

Influence - His theory was put to test during the World War II when the Heartland could become the power centre of the world if either Germany unites with Russia or China or Japan thrashes Russia. But the shattering defeat of Germany turned Heartland into a power vacuum.

The area highlighted in red is the heartland, blue is rim land and the encircled area is the world island.

The heartland is inaccessible from top because North Sea, Norwegian Sea, Barents Sea, Kara Sea, Laptev Sea, East Siberian Sea are all frozen throughout the year. The heartland is inaccessible from the bottom because of Middle Eastern desert, Iranian Plateau, Himalayas, Plateau's of Tibet and Siberian mountains. This makes heartland immune to any conquests from any other side than Eastern Europe.

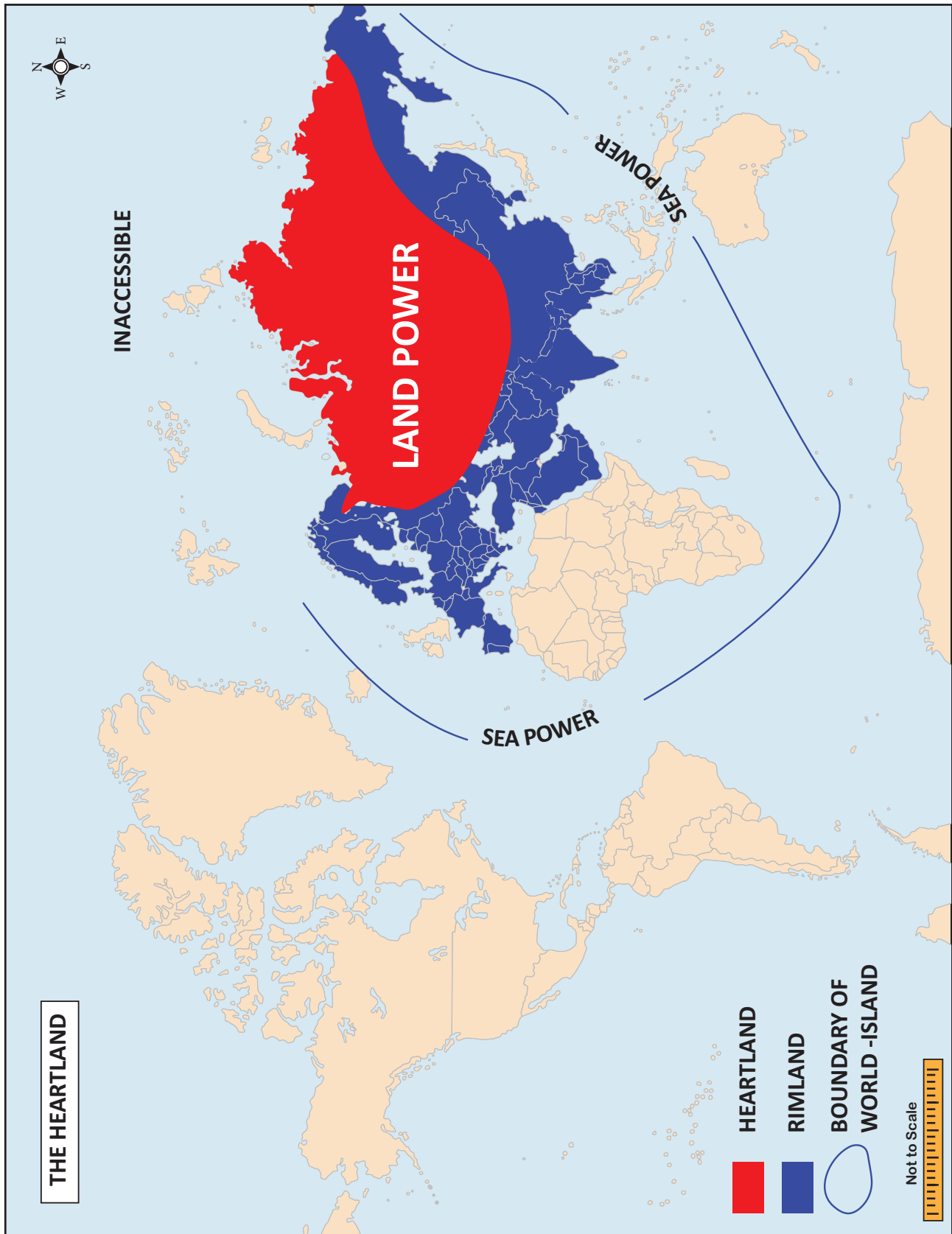

The only gateway to the heartland is through Eastern Europe. So, protecting one gateway would be far easier than protecting the whole land. Moreover, the heartland was self sufficient with most of the resources and wasn't dependent on trade from outside world.

So, Mackinder believed that the one who controls the heartland would be able to control the Rimland and as a result the world-Island, and the one, who rules the world Island, would rule the world. Although this theory made sense at that time (1904), when there was no significant aviation and naval power, it does not make much sense now.

5.5.3 21st Century Geopolitics of the multipolar world order

To put it succinctly, the unipolar world is characterized by the US' predominant hegemony in a wide variety of spheres, whether exercised directly through unilateral initiatives or indirectly ("Lead From Behind") through its regional and institutional partners. The Multipolar forces in the world are working to replace the US-led international order with a diversified array of multiple stakeholders in order to bring balance to International Affairs. Importantly, they seek to do this through progressively reforming international institutions such as the UN, IMF, World Bank, and others, as well as creating their own counterparts to some of them like the BRICS New Development Bank or outright forming entirely new and unprecedented organizations like the SCO.

One of the latest proposals has been to broaden the BRICS format through what has now been called the "BRICS-Plus" strategy, which essentially seeks to have each of the five member states encourage multilateral cooperation between each other's respective regional integration organizations. As Russian Valdai Club expert Yaroslav Lissovlik describes it, this could see Mercosur, the SADC, the Eurasian

Economic Union, SCO, SAARC, and ASEAN all cooperating with one another in changing the world order.

Missile Defense Shield, Prompt Global Strike, and the Naval Race

The basis of American control over the world is through economic means as enforced by military ones. In certain cases, though, the US is unable to directly attack its rivals such as Russia and China without suffering unacceptable damage through a nuclear second strike, ergo why Washington is pushing to build anti-missile installations all around Eurasia in order to ring in these Great Powers and diminish their most credible deterrent capability. Complementary with this are the US' space weapons, whether based in this theatre (X37-B and the policy of "Prompt Global Strike") or directed towards it (anti-satellite weapons, whether kinetic such as missiles or non-kinetic like lasers).

Neither the US' missile shields nor its space-related weaponry are sufficient enough for ensuring that the country is defended from submarine-launched ballistic missiles, which form a crucial component of any country's nuclear triad. This explains why there's an ongoing naval race across the world as the US seeks to ensure its dominance in the high seas in the face of rising competition from Russia, China, and others. The global ocean is also important for another reason as well, and this one relates back to the economic basis of American dominance over the world. China depends on the international waterways for the vast majority of its trade, which makes it inordinately vulnerable to any US efforts to block certain chokepoints such as the Strait of Malacca and Suez Canal.

OBOR's Global Reorganization

Understanding the sudden systemic-shaking consequences that any hostile action like this could inflict for China's domestic

socio-economic stability, the People's Republic prudently foresaw the need to pioneer ambitious trans-continental trade routes to its crucial European partner, as well as secure the Sea Lines Of Communication (SLOC) along its existing maritime ones in order to safeguard its access to the growing economics of Africa. The latter are exceptionally important nowadays because their growth is expected to allow Beijing to relieve itself of its industrial overproduction so long as it can succeed in building up these marketplaces and stabilizing them. As for the Western Hemisphere, China wants to increase its soft presence here as a means of competing with the US and asymmetrically countering America's moves in the South China Sea.

Altogether, the above stratagem explains the essence of China's One Belt One Road (OBOR) global vision of New Silk Road connectivity, which is designed to transform the world's trading networks so as to facilitate the transition from a unipolar American-led international order to a diversified Multipolar one safeguarded by a host of Great Powers.

To live in a world where geography is respected and not ignored is to understand the constraints. Many obstacles simply cannot be overcome. That is why the greatest statesmen work near the edges of what is possible. Geography establishes the broad parameters—only within its bounds does human agency have a chance to succeed.



GLOSSARY

1. **Heritage** – culture that may be inherited.
2. **Folk**- Relating to traditional art or culture of a community.
3. **Confucianism** - a religion based on the ideas of the Chinese philosopher Confucius.
4. **Nationalism** - the feelings of affection and pride that people have for their country.
5. **Cyberwarfare** - The use of the internet to attack an enemy, by damaging things such as communication and transport systems or water and electricity supplies.
6. **Frontier** - It is a geographical boundary between the countries.
7. **Mongoloid** - a member of a group of people who mainly live in Mongolia.
8. **Semitic** – refers to the race of people that includes Arabs and Jews, or to their languages.
9. **Monotheistic** - refers to the belief that there is only one god.
10. **Geopolitics** - the study of the way a country's size, position, etc. influence its power and its relationships with other countries.

Exercise



I. Choose the correct answer.

1. Which of the given statements is true?

- a) India has the world's highest number of languages.
- b) India has the world's third highest number of languages, after China and Russia.
- c) India has the world's second highest number of languages, after Papua New Guinea.
- d) India and England have the third and fourth highest number of languages respectively.

2. Which of the following is untrue about the Occidental realm?

- a) West European is the most industrialised and urbanised culture.
- b) Continental European culture is influenced by different political and economic thoughts, while Islam remains an important influence.
- c) Mediterranean Europe includes countries lying to the south of the Alps. It is the region of dominance of Christianity.
- d) Anglo-American and Australian cultural realms are practically the offspring's of west European culture.

3. It is estimated that one language dies out every.

- a) 14 minutes
- b) 14 days
- c) 14 months
- d) 14 years

4. Of the UNESCO's five levels of language risk, definitely endangered languages children do not speak are

- a) 457 languages
- b) 970 languages
- c) 646 languages
- d) 374 languages

5. Who stated the following?

“Who rules East Europe commands the Heartland.

Who rules Heartland commands World Island.

Who rules World Island commands the World”.

- a) Humboldt
- b) Hutton
- c) Spikeman
- d) Mackinder

6. Which country has the maximum number of neighbours touching its border?

- a) China
- b) Canada
- c) Russia
- d) India

7. Which of the following is an example of Relict Boundaries?

- a) Persia and the boundary between east & West Germany
- b) Pakistan occupied Kashmir
- c) N. Africa and the state boundaries of USA
- d) The countries of Europe

8. The Heartland theory was proposed by

- a) Humboldt
- b) Hutton
- c) Spikeman
- d) Mackinder

9. All of the following are supporting the Heartland theory of Mackinder except,

- The heartland is inaccessible from top because North Sea, Norwegian Sea, Barents Sea, Kara Sea, Laptev Sea, East Siberian Sea are all frozen throughout the year.
- The heartland is inaccessible from the bottom because of Middle Eastern desert, Iranian Plateau, Himalayas, Plateau's of Tibet and Siberian mountains.
- The only gateway to the heartland is through Eastern Europe.
- This makes heartland immune to any conquests from any other side.

10. Which one is rightly matched?

- Austrian – Munda, Mon-Khmer.
- Sino – Hindi, Urdu, Sans.
- Indo-Aryan – Tibetan, Bodo, Karen, Manipuri, etc.
- Dravidan – Sans, Karen, Manipuri, etc.

II Very short answers

- Name any two tribes living each in
Equatorial Forest region:
Grasslands:
Tropical deserts:
Mountainous region:
- Write a short note on Todas.
- On what bases the race is classified into? Name them.
- What are the four linguistic families Indian Languages mainly belong to?
- Write a short note on Indian Cultural Realm

III Short answers

- Write a short note on OBOR
- Distinguish between Frontier and Boundary.
- Define cultural realm and mention its major divisions.
- How is Caucasoid different from Mongoloid?
- What did Mackinder divide the earth into? Explain them in short.

IV Detailed answers

- Describe the Genetic Classification of the boundaries.
- Explain the major Languages of India
- On the outline map of the world, show the three tier boundaries of Heartland theory.

Activity

Feature	Caucasoid	Mongoloid	Negroid
Skin colour	Pale reddish white to olive brown.		Brown to black brown yellow brown.
Stature	Medium to Tall.	Medium tall to Medium Short.	Tall to very Short.
Face		Medium broad to very broad molars high and flat tends to medium high	
Head Form	Long-broad and Short Medium, high-very high.		Predominantly long, Low height.
Hair color		Brown to brown black, Straight.	Brown black light curl and wooly.
Body Build	Linear to lateral slender to refuge.		Tend to be linear and muscular.
Nose	Usually high, narrow to medium board.	Low to medium form, medium broad.	
Blood Group		High in B.	High is Rh(D).
Eye	Colour: light blue to dark brown , lateral eye – fold occasional		Colour: brown to brown black, vertical eye – fold common



Reference

1. Cultural geography, Majid Husain
2. Cultural geographies. An Introduction, John Horton and Peter Kraftl
3. Political geography, Sudeepta Adhikari



ICT CORNER

CULTURE AND POLITICS

This activity enables the students to understand about the Cultures of the different countries as videos. A great activity.



Steps

- Type the URL link given below in the browser or scan the QR code. A page opens with colorful pictures
- When we touch it, It opens into another page with many options
- When we select the required or desired country it opens into another page.
- It contains a video. That video contains all the cultural things of the country like food, cloth etc.



Step 1

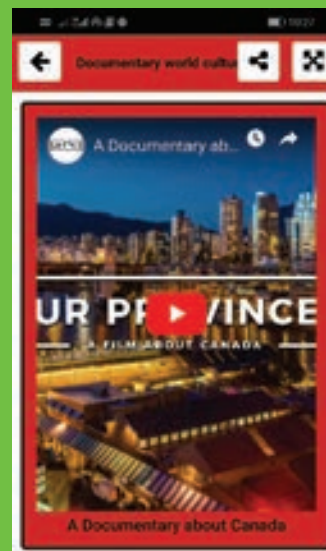

Step 2

Website URL:

[Play.google.com/store/apps/details?id=culturalsdelmundo.documentaldeculturals.com](https://play.google.com/store/apps/details?id=culturalsdelmundo.documentaldeculturals.com)

*Pictures are indicative only.



UNIT 6

Geoinformatics

Unit Overview

- 6.1 Introduction
- 6.2 Remote sensing
- 6.3 Geographic Information System (GIS)
- 6.4 Global Navigation Satellite System (GNSS)

6.1 Introduction

Geoinformatics is the integration of remote sensing, Global Navigation Satellite System and Geographic Information System dealing with spatial information. The advent of remote sensing, Global Navigation Satellite System and Geographic Information System has made significant changes in surveying and map making. A basic understanding of these components is crucial for carrying out various types of surveys, navigation, hydrology, disaster management, etc.

The field of Remote Sensing and GIS has become exciting with rapidly expanding opportunities. Geoinformatics has three major components namely remote sensing, GIS and GNSS.



Learning Objectives

- To understand major divisions of Geoinformatics- Remote sensing, GNSS, GIS
- To value the application of remote sensing in various fields
- To learn to define GIS and understand its usage, in general, learn to calculate spatial data and its analysis (Raster and vector data).



6.2 Remote sensing

Remote sensing is an integrated discipline encompassing some branches of arts, science and technology of collecting information about the terrestrial objects using camera and sensor system.

Elements of Remote Sensing

1. Energy Source

The primary requirement for remote sensing is to have an energy service, which provides electromagnetic energy to the target of interest. The sun being a major source of energy, radiation and illumination having a sharp power allows capturing reflected light with conventional cameras and films.

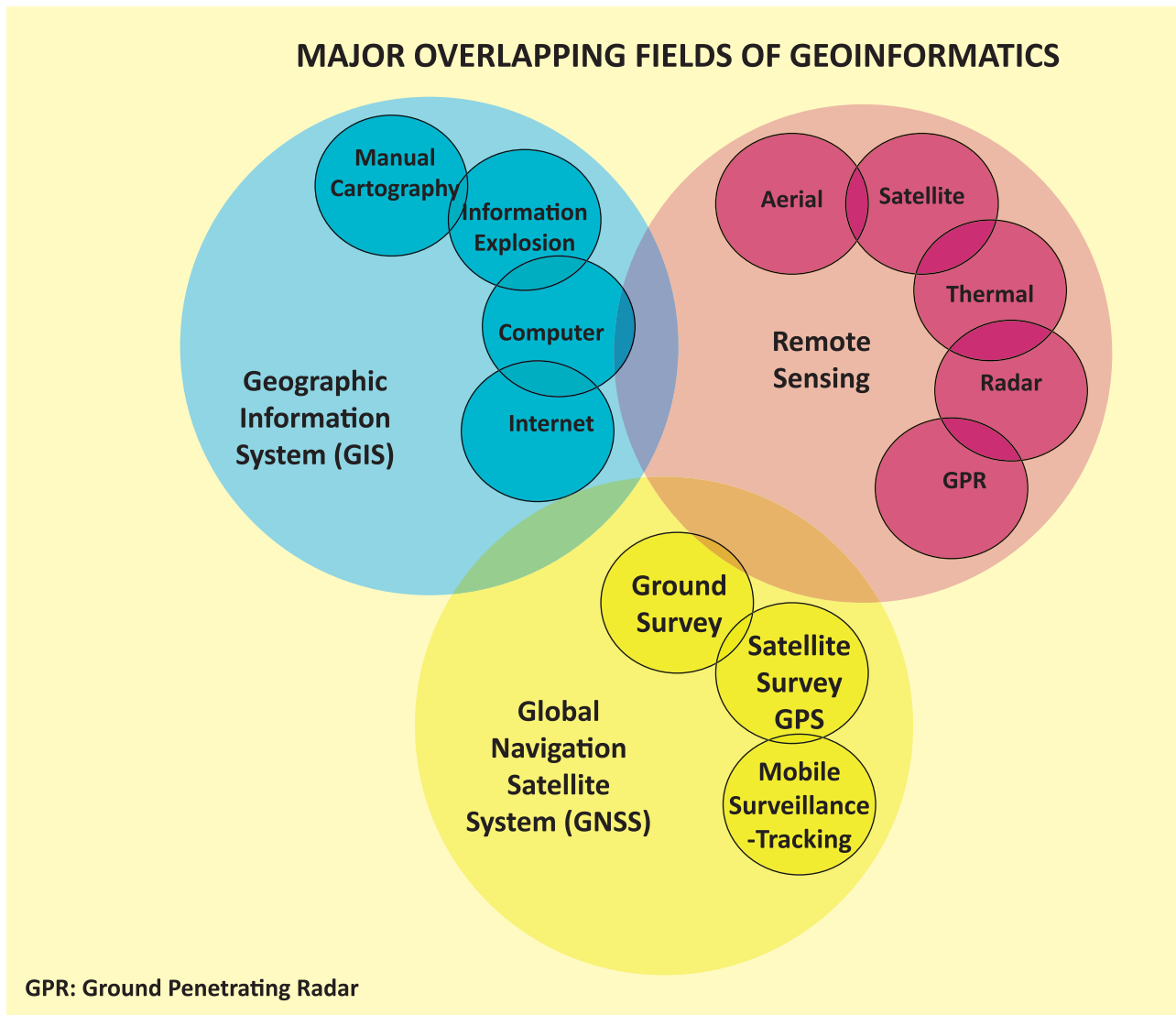

2. Radiation and the Atmosphere

The energy is required to illuminate the target. This energy is in the form of Electromagnetic radiation. Electromagnetic radiation is a dynamic form of energy that propagates as wave motion at a velocity in space.

3. Interaction with the target

The interaction of Electromagnetic radiation with the target is important to remote sensing for two main reasons. First, information carried by Electromagnetic radiation reflected by the earth's surface is modified while traversing through the atmosphere. Second, the interaction of Electromagnetic radiation with the

atmosphere can be used to obtain useful information about the atmosphere itself. The total energy is subjected to modification by the several physical processes, scattering, absorption and refraction. **Scattering** is the re-direction of Electromagnetic radiation by particles suspended in the atmosphere or by large molecules of atmospheric gases. The amount of scattering depends upon the size of the particles and their abundance. The wavelength of radiation, depth of the atmosphere through which the energy is travelling. **Absorption** is the process by which the gas molecules present in the atmosphere strongly absorb the Electromagnetic radiation through the atmosphere in certain spectral bands.

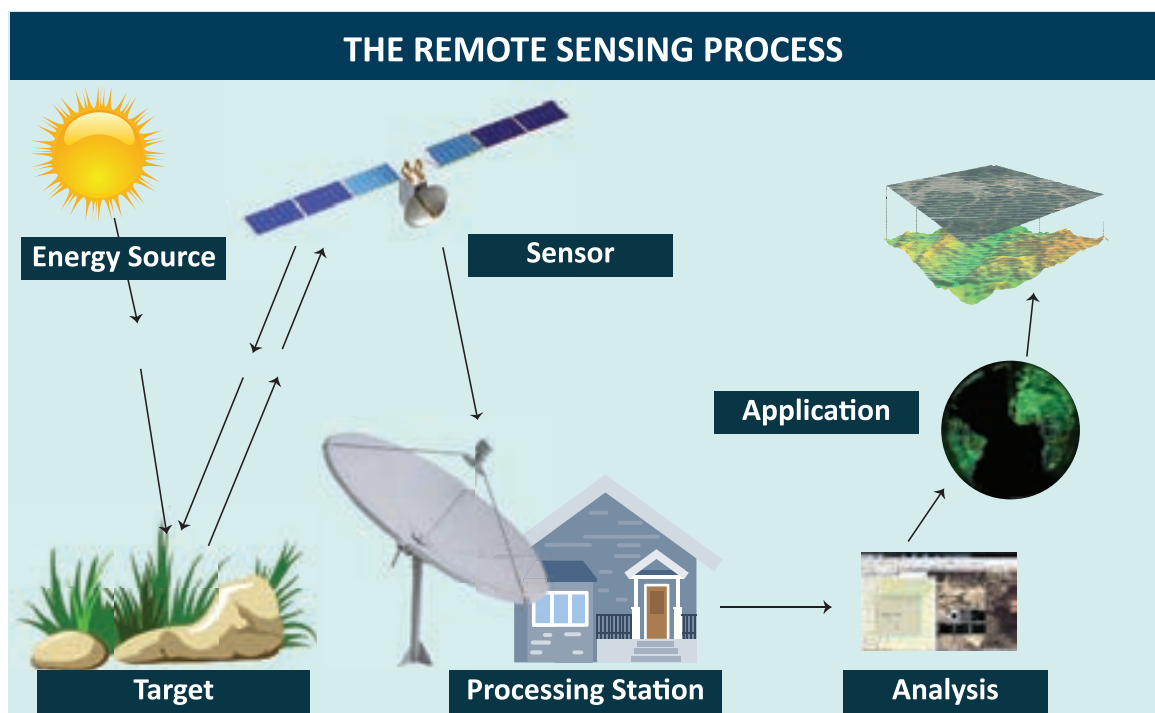

4. Recording of energy by the sensor

After the energy has been scattered by or emitted from the target, we require a sensor (remote not in contact with the target) to collect and record the electromagnetic radiation. A sensor is highly sensitive to all the wave lengths yielding spatially detailed data on absolute brightness. On the basis of the source of electromagnetic energy, the sensor can be classified into two ways. They are **active sensor** or **passive sensor**. Active sensor generates and uses its own energy to illuminate the target and records the reflected energy. It operates in the microwave regions of the electromagnetic spectrum. Their wave lengths are longer than 1 mm.

5. Transmission, Reception and Processing

The energy recorded by the sensor has to be transmitted in electronic form, to a receiving and processing station where the data processed into an image. The Image processing methods may be grouped into three functional categories such as Image Restoration, Image Enhancement and Information Extraction.

Image Restoration: Restoration processes are designed to recognize and compensate for errors, noise and geometric distortion introduced into the data during the scanning transmission and recording processes. The objective is to make the image resemble the original scene. Image restoration is relatively simple because the pixels from each band are processed separately.

Image Enhancement: Enhancement is the modification of an image, to alter its impact on viewer. General enhancement distorts the original digital values; therefore enhancement is not done until the restoration processes are completed.

Information extraction: Image restoration and enhancement process utilize computers to provide corrected and improved images for study by human interpreters. The computer makes no decision in these procedures. The human operator must instruct the computer and must evaluate the significance of the extracted information.

6. Interpretation and Analysis

Image interpretation is defined as the act of examining images to identify objects

and judge their significance. An interpreter studies remotely sensed data and attempts through logical process to detect, identify, measure and evaluate the significance of environment and cultural object pattern and spatial relationship.

The quality of an image is based on the inherent characteristics of the objects. Further it depends on the following aspects.

- Sensor characteristics
- Season of the year, time of the day when the photo is taken
- Atmospheric effects
- Resolution of the image
- Image motion etc.

Image interpretation is essential for the efficient and effective use of the data. The elements of image interpretation such as image tone, shape, size, pattern, image texture, shadow and association are helpful to identify the exact target and to analyse.

Classification of remote sensing

On the basis of the sources of electromagnetic energy, the remote sensing can be classified as passive and active remote

sensing. In a simple way, we can understand that the passive remote sensing is similar to taking a picture with an ordinary camera where as active remote sensing is analogous to taking picture with camera having built-in flash.

On the basis of the energy source, the active remote sensing generates and uses its own energy to illuminate the target and records the reflected energy where as the passive remote sensing depend on solar radiation to illuminate the target. On the basis of region of spectrum in which they operate, the active remote sensing operate in the microwave region of the electromagnetic spectrum where as the passive remote sensing operate in the visible and infrared region of the electromagnetic spectrum. The wave lengths of the active remote sensing are longer than 1 mm where as the passive remote sensing, the wave length range from 0.4 to 1.0 mm.

Some examples of active sensors are Fluorosensor and Synthetic Aperture Radar (SAR). Passive sensors record radiation reflected from the earth's surface. The source of this radiation must come from outside the sensor; in most cases, this is solar energy. Because of this energy requirement, passive

Passive sensors



Active sensors

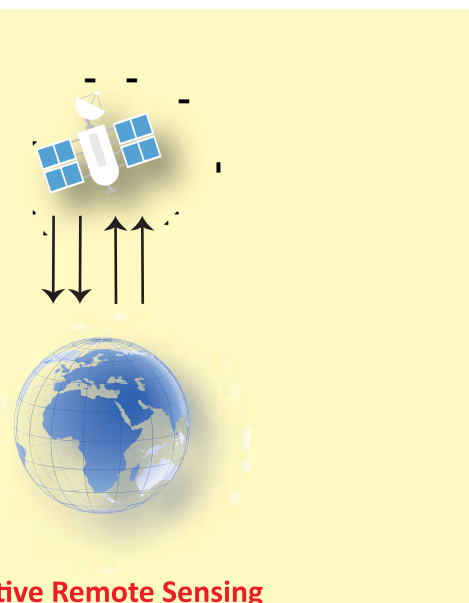



solar sensors can only capture data during daylight hours. **Active sensors** are different from passive sensors. Unlike passive sensors, active sensors require the energy source to come from within the sensor. A laser-beam remote sensing system is an active sensor that sends out a beam of light with a known wavelength and frequency. This beam of light hits the earth and is reflected back to the sensor, which records the time it took for the beam of light to return.

Remote sensing platform

The platform is a stage to mount the camera or sensor to acquire the information about a target under investigation. Based on the altitude above the earth surface, the platform can be classified as Ground borne platform, Air borne platform and Space borne platform.

Ground borne platform

Ground based platforms sensors may be placed on a ladder, scaffolding tall-building, crane etc. These are used to record detailed information about the surface which is compared with information collected from aircraft or satellite sensors. They are close to the ground.



Mobile Hydraulic Platforms

A wide variety of ground based platforms are used in remote sensing. Some of the more common ones are hand held devices, tripods, towers and cranes. Instruments that are ground-based are often used to measure the quantity and quality of light coming from the sun or for close range characterization of objects. Permanent ground platforms are typically used for monitoring atmospheric phenomenon although they are also used for long-term monitoring of terrestrial features.

Air borne platform

Aircrafts are generally used to acquire aerial photographs for photo interpretation and photogrammetric purposes. They are classified into two types. They are

- Low altitude aerial remote sensing
- High altitude aerial remote sensing

Balloon

Balloons are used for remote sensing observation (aerial photography) and nature conservation studies. The first aerial images were acquired with a camera carried aloft by a balloon in 1859. Balloon floats at a constant height of about 30 km.



Weather Surveillance Radar



Drone

Drone is a miniature remotely piloted aircraft. It is designed to fulfil requirements for a low cost platform, with long endurance, moderate payload capacity and capability to operate without a runway or small runway. Drone includes equipment of photography, infrared detection, radar observation and TV surveillance. It uses satellite communication link. An onboard computer controls the payload and stores data from different sensors and instruments. The unique advantage is that it could be accurately located above the area for which data was required and capable to provide both night and day data.

Aircraft

The first known aerial photograph was taken in 1858 by French photographer and balloonist, Gaspar Felix Tournachon, known as "Nadar". In 1855 Special aircraft with cameras and sensors on vibration less platforms are traditionally used to acquire aerial photographs and images of land surface features. While low altitude aerial photography results in large scale images providing detailed information on the terrain, the high altitude smaller scale images offer advantage to cover a larger study area with low spatial resolution.

Space borne platform

The satellites are normally used for the space borne remote sensing. The satellite moves in their orbit. The closed path of a satellite around the earth is called its orbit. These platforms are freely moving in their orbit around the earth and the entire earth or any part of the earth can be covered at specified intervals. The coverage mainly depends on the orbit of the satellite. It is through these space borne platforms, we get the enormous amount of remote sensing data. In space borne remote sensing, sensors



are mounted on-board a spacecraft (space shuttle or satellite) orbiting the earth. Space borne remote sensing provides the following advantages:

1. Large area coverage.
2. Frequent and repetitive coverage of an area of interest.
3. Quantitative measurement of ground features using radio metrically calibrated sensors.
4. Semi automated computerised processing and analysis.
5. Relatively lower cost per unit area of coverage.

Types of satellite

Satellite orbits are designed according to the capacity and objective of the sensors they carry. Depending on their altitude, orientation and rotation relative to the earth satellites can be categorized as

- 1) Geostationary satellite
- 2) Polar Orbiting or Sun-Synchronous satellite
- 3) Spy satellite

1. Geostationary Satellites

Geostationary Satellite is an equatorial west to east satellite orbiting the earth at an altitude of 35000 km, the altitude at which

APPLE being tested on a bullock cart

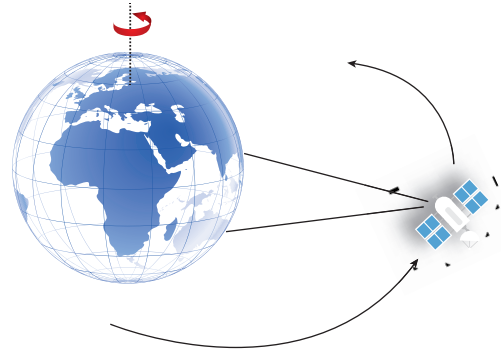

it makes one revolution in 24 hours. These platforms are covering the same place and give continuous near hemispheric coverage over the same area day and night. These satellites are put in equatorial plane orbiting from west to east. Its coverage is limited to 70°N to 70°S latitudes and one satellite can view one-third globe. These are mainly used for communication and meteorological applications viz. GOES, METEOSAT, INTELSAT, and INSAT satellites. On June 19, 1981 India launched its first geostationary satellite called APPLE. It was an experimental communication satellite launched by the Indian Space Research Organisation (ISRO).

The Ariane Passenger Payload Experiment (APPLE) was ISRO's first indigenous, experimental communication satellite.



India is the only one country which has reached to the mars in its first attempt.

2. Polar Orbiting or Sun-Synchronous satellite

As the satellite orbits the Earth from pole to pole, its east-west position would not change if the Earth did not rotate. However, as seen from the Earth, it seems that the satellite is shifting westward because the Earth

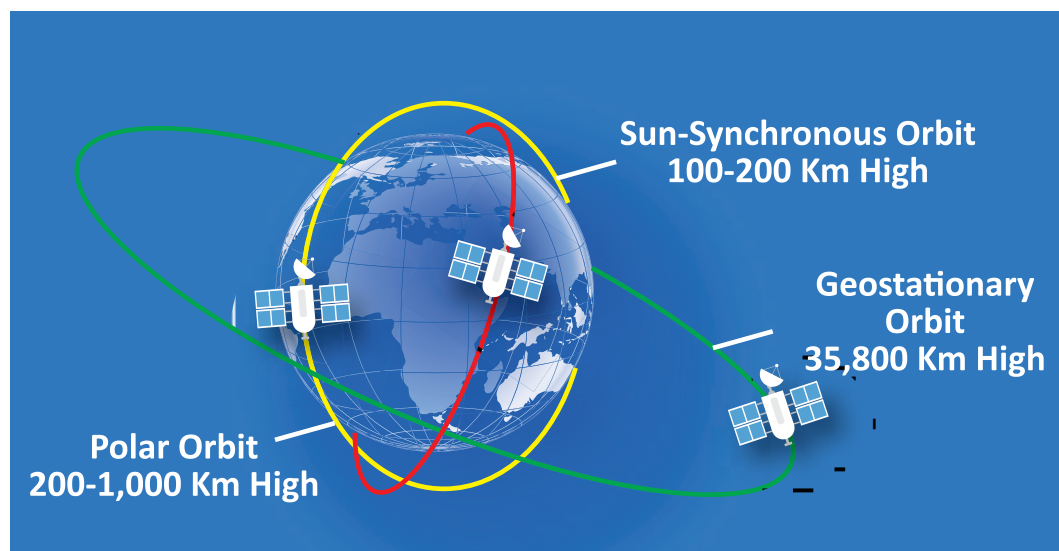

Satellite orbits: Sun-synchronous orbit source E: Campbell, 2007

is rotating (from west to east) beneath it. This apparent movement allows the satellite swath to cover a new area with each pass. All the remote sensing resource satellites may be grouped in this category. Few of these satellites are LANDSAT series, SPOT series, IRS series, NOAA SEASAT, TIROS, HCMM, SKYLAB, and SPACE SHUTTLE etc.

3. Spy satellites

Spy satellites are observational platforms that orbit the Earth in order to image its surface and to record radio signals for military and political purposes. They transmit their data to Earth, where it is interpreted by specialists in centralised, secretive facilities such as the U.S. National Photographic Interpretation Centre in Washington, D.C. Spy satellites have been essential not only to military operations and the formation of national policy but to the verification of arms control treaties such as SALT I, SALT II, etc.

The four basic types of spy satellite are:
(1) photo reconnaissance systems that take

pictures in visible and infrared light, (2) infrared telescopes designed to detect missile launches, (3) radars that image sea or land even through cloud cover and in darkness, and (4) signals intelligence (SIGINT) satellites (also termed "ferrets"), which are optimised either for characterising ground-based radar systems or for eavesdropping on communications. Sometimes photo reconnaissance and SIGINT functions are combined in single, massive platforms such as the U.S. Keyhole-series satellites.

Although a number of nations have launched spy satellites, the U.S. and the Soviet Union are responsible for by far the greatest number. The Russian Federation, which inherited most of the Soviet Union's space system after 1991, has been unable to afford the cost of adequately updating its spy satellite network. In contrast, the U.S. has continued to deploy ever-more-sophisticated systems in a steady stream. Thus, the majority of spy satellites in orbit today, including all the most capable units, are U.S.-owned. Early U.S. Satellites: Corona, MIDAS, SAMOS.

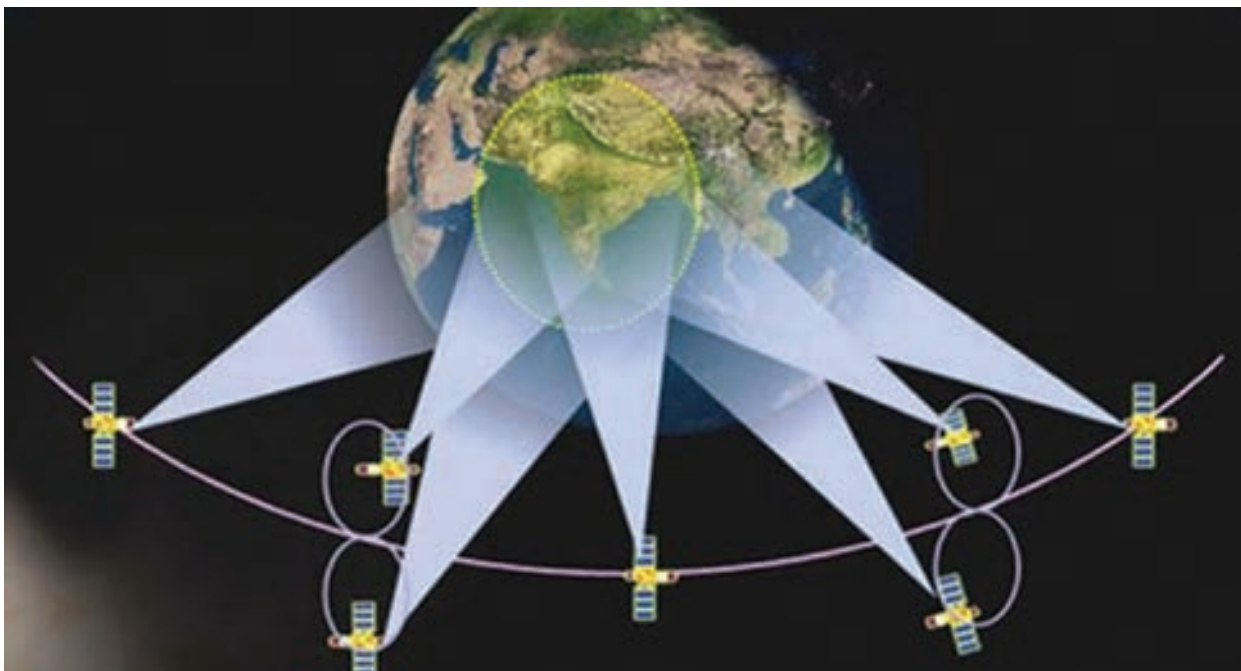

India's NAVIC satellite



The Gaofen 4 is the world's most powerful GEO spy satellite (launched in 2015) which can provide instant coverage of earthquake or typhoon hit areas to support humanitarian relief. It will also allow China to monitor strategic foreign sites such as WMD facilities and naval bases inside its observation box.

Applications of remote sensing

1. Agriculture

The satellites have ability to image individual fields, regions and countries on a frequent revisit cycle. Customers can receive field-based information including crop identification, crop area determination and crop condition monitoring (health and viability). Satellite data are employed in precision agriculture to manage and monitor farming practices at different levels.

2. Forest Management

The forest - fire, sudden deforestation, encroachment of forest- land are recent challenges to the ecologist. It can be easily identified and curbed with the help of remote sensing satellite pictures.

3. Geology

Various fields Remote sensing techniques used in geology are

- Lithological mapping



CASE STUDY

NASA launches world's lightest satellite designed by 18-year-old Tamil Nadu student.



India once again broke a global space record by launching the world's lightest satellite weighing a mere 64 grams, called Kalamsat. It was designed and developed not by professional space scientists and engineers, but by 18-year-old Tamil Nadu student Rifath Sharook and his team. The tiny satellite, named after Abdul Kalam, was flown by a NASA sounding rocket on 22 June, 2017 and Kalamsat was the only Indian payload in the mission. Mission director Srimathy Kesan that the total flight time of the rocket was 240 minutes. The satellite, assembled at her T.Nagar residence in Chennai. The satellite was separated from the rocket after spending 125 minutes in the space's micro-gravity environment. Sharook's project, the first to be manufactured via 3D printing, got selected through a competition, 'Cubes in Space', sponsored jointly by NASA and 'I Doodle Learning'. The project aims to take the performance of new technology to space.

- Structural mapping
- Geomorphological mapping
- Mineral exploration
- Hydrocarbon exploration
- Sedimentation mapping and monitoring
- Geo-hazard mapping

4. Oceanography

Satellite remote sensing plays an important role in coastal zone management. It allows us to locate and regularly monitor various aspects such as bathymetry (the measurement of the depth of water in water bodies), chlorophyll content, suspended sediment concentration, etc.

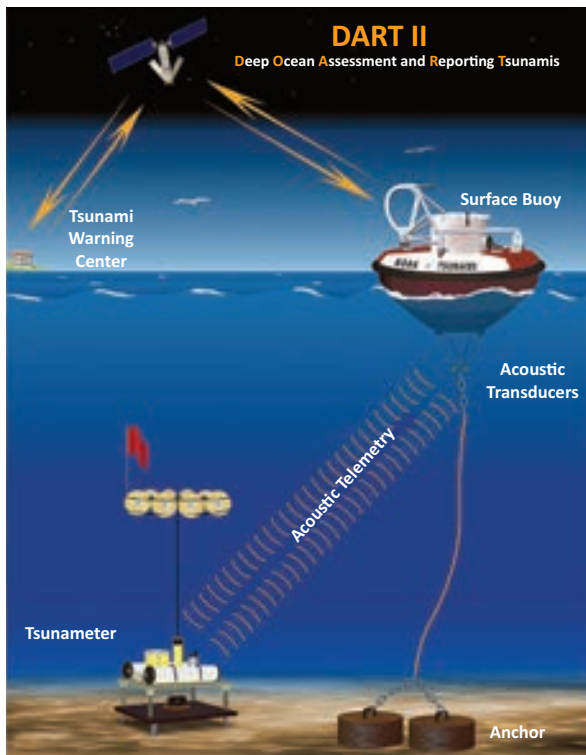

5. Cartography

Remote sensing aids in extensive surveys that are made from high altitudes to show the urban development, rural development, mountain areas, deserts, etc which help the cartographers. High-resolution satellite cameras located at altitudes of several hundred kilometres can record details as small as a few metres on the surface of the Earth.

6. Meteorology

The radar system is basically used to collect the weather data. It collects meteorological data from unmanned land/ocean based Data collection platforms and serves as a communication satellite for rapid exchange of meteorological data among centres and for rapid dissemination of weather forecasts warnings etc, to user agencies.



Weather satellite Picture

7. Topography

Topography specifically involves the recording of relief or terrain, the three-dimensional quality of the surface, and the identification of specific landforms. Topographic maps usually portray both natural and manmade features. They show and name works of nature including mountains, valleys, plains, lakes, rivers, and vegetation. They also identify the principal works of man, such as roads, boundaries, transmission lines, and major buildings.

8. Urban Planning

These information systems also offer interpretation of physical (spatial) data with other socio-economic data, and thereby providing an important linkage in the total planning process and making it more effective and meaningful. Digitization of planning base maps has facilitated updating of base maps wherever changes have taken place in terms of land development etc. Superimposition



Satellite Image of an urban centre

of any two digital maps which are on two different scales is feasible.

6.3 Geographic Information System (GIS)

The Geographic information systems have emerged in the past two decades as an essential tool for urban and resource planning and management. It includes the functions of data entry, data display, data management,

information retrieval and analysis. While GIS deals with entire geography of the earth including land, ocean and atmosphere, the art, science and technology dealing with the acquisition, storage, processing, production, presentation and dissemination of the earth's information is called the Geoinformatics. It is the popular means of studies in recent decades which cater the real and useful information to the field of Geography, Environmental Studies, Town planning, Rural development studies, and Defense and Agricultural promotion.

Generation of the computers

- 1940 – 1956: First Generation – Vacuum Tubes
- 1956 – 1963: Second Generation – Transistors
- 1964 – 1971: Third Generation – Integrated Circuits
- 1972 – 2010: Fourth Generation – Microprocessors
- 2010 – Fifth Generation – Artificial Intelligence

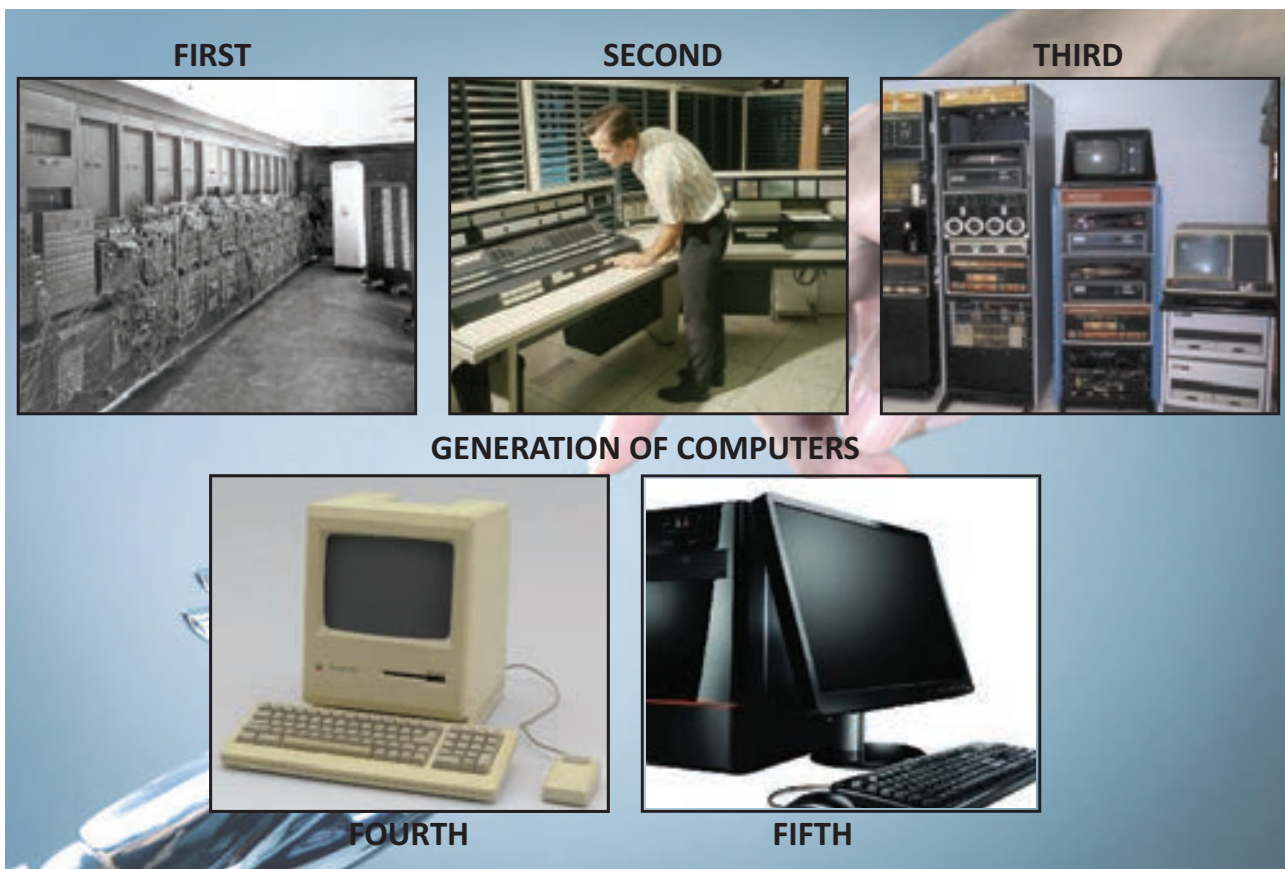

Components of GIS

The components of GIS can be broadly classified into five types. They are mentioned below.

A. Hardware

Hardware is Computer on which GIS software runs. Nowadays there are a different ranges of computer, it might be Desktop or server based. ArcGIS Server is server based computer where GIS software runs on network computer or cloud based. For computer to perform well all hardware components must have high capacity. Some of the hardware components are: Motherboard, Hard drive, processor, graphics card, printer and so on. These all component function together to run GIS software smoothly.

B. Software

Next component is GIS software which provides tools to run and edit spatial information. It helps to query, edit, run and display GIS data. It uses RDBMS (Relational Database Management System) to store the data. Few GIS software list: ArcGis, ArcView 3.2, QGIS, SAGA GIS.

C. Data

Geographic data and related tabular data can be collected in-house compiled to custom specifications and requirements (or) purchased from a commercial data provider.

A GIS can integrate spatial data with other existing data resources often stored in a corporate data base management System. The data can be broadly classified as

- i. Attribute data
- ii. Spatial data
- iii. Remote sensing data
- iv. Global data base.

You will learn in detail about each of the above classification of data in higher studies.

D. People

The GIS technology is used by a huge number of industrialists and agencies to help plan, design, engineer, build and maintain information infrastructures that affects our everyday lives.

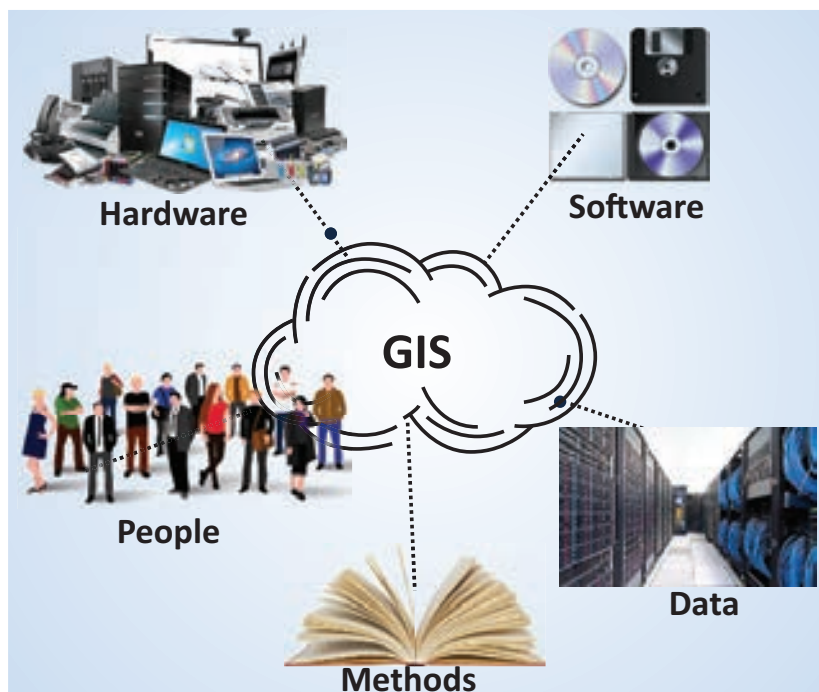

E. Methods or Procedures

Methods here refer to well-defined, consistent procedures that are required to produce accurate, reproducible result. A neatly conceived implementation plan and business rules are the models and operating practices are unique to each organization. There is need to properly integrate the sophisticated tool through bringing out well-defined procedures in well documented form into the entire business strategy and operation to make the technology effective. Meta data i.e., (data about the data) is the key for documenting these processes.

Functions of GIS

The functions of GIS describe the steps that have to be taken to implement a GIS. These steps have to be followed in order to obtain a systematic and efficient system. The steps involved are data capture, data storage (GIS Data Models), manipulation and analysis.

Data Capture

The input of data into a GIS can be achieved through many different methods of gathering. For example, aerial photography, scanning, digitizing, GNSS is just a few of the ways a GIS user could obtain data. Digitization: A conversion process which converts paper maps into numerical digits that can be stored in the computer. Digitizing simplifies map data into sets of points, lines or cells that can be stored in the GIS computer. In this stage, digitization is carried out. There are two basic methods of digitization: Manual digitizing & scanning.

Data Storage

Some data is stored such as a map in a drawer, while others, such as digital data, can be as a hardcopy, stored on CD or on your hard drive. Once the data have been digitally compiled, digital map files in the GIS are stored on magnetic or other digital media. Data storage is based on a

Generic Data Model that is used to convert map data into a digital form. The two most common types of data models are Raster and Vector. Both types are used to simplify the data shown on a map into a more basic form that can be easily and efficiently stored in the computer.

Data Manipulation

The digital geographical data can be edited, this allows for many attribute to be added, edited, or deleted to the specification of the project. Once data are stored in a GIS, many manipulation options are available to users. These functions are often available in the form of “Toolkits.” A toolkit is a set of generic functions that a GIS user can employ to manipulate and analyse geographical data. Toolkits provide processing functions such as data retrieval measuring area and perimeter, overlaying maps, performing map algebra, and reclassifying map data. Data manipulation tools include coordinate change, projections, and edge matching, which allow a GIS to reconcile irregularities between map layers or adjacent map sheets called Tiles.

Query and Analysis

GIS was used widely in decision making process for the new commission districts. We use population data to help establish an equal representation of population to area for each district. The heart of GIS is the analytical capabilities of the system.

6.4 Global Navigation Satellite System (GNSS)

GNSS refers to the collection of the world's global satellite based positioning systems. It includes GPS (United States) GLONASS (Russia) GALILEO (European Union) BEODOU (China) IRNSS (India) QZSS (Japan). GNSS can provide centimetre level accuracy with a low-cost receiver, if an error correction technique is used. GNSS are recognized to be the systems of choice in outdoor environments and, to a great extent,

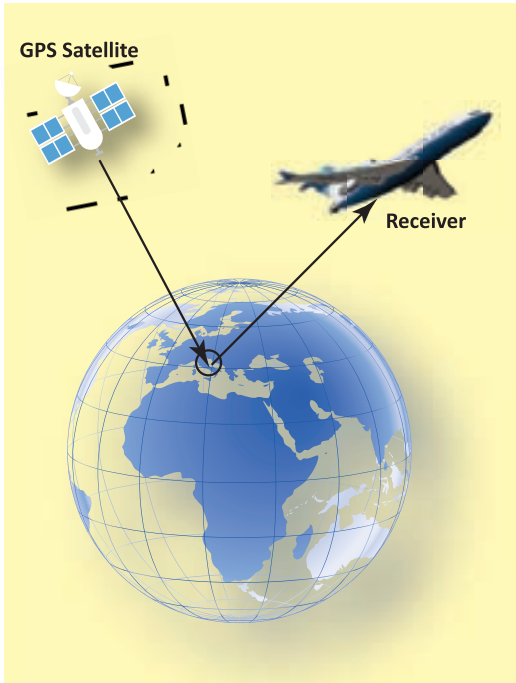

GNSS bi static radar with the GPS satellite

one of the most accurate source of position (and precise timing) information when it is available.

The first satellite navigation system was **Transit**, a system deployed by the US military in 1960's. Transit's operations were based on the Doppler Effect: the satellites travelled on well-known paths and broadcast their signals on well-known radio frequency. The received frequency will differ slightly from the broadcast frequency because of the movement of the satellite with respect to the receiver. The satellite broadcast signals that contains orbital data (from which the position of the satellite can be calculated) and the precise time, the signals is transmitted. There are multiple constellations of GNSS satellites orbiting the earth. GNSS satellites' orbit situated about 20,000 km above the earth's surface. They are moving very fast, several kilometres per second. The latest generation of GNSS satellites (Block IIF) weight over 1,400 kg.

GNSS system operated in different countries

The following are the Global Navigation satellite Systems:

GPS (United States)

GPS was the first GNSS system. GPS was launched in the late 1970s by the United States Department of Defence. It uses a constellation of 24 satellites, and provides global coverage.

GLONASS (Russia)

The premier Soviet military navigation network was to be comprised of Uranan satellites. At the end of the Cold War, the constellation was unclassified under the name GLONASS -- a Russian abbreviation of Global Navigation Satellite System. Global Navigation Satellite System by Russian Aerospace Defence Forces is a space-based satellite navigation system.

The life style of GNSS satellites 5-7 years and new satellites are to be launched after a specific time interval in order to fill the gap due to ageing satellites. GLONASS proves very beneficial for Russian territory by 2010. In 2011, restoration of system is improved to enable full global coverage.



GALILEO (European Union)

Galileo is Europe's own global navigation satellite system, providing a highly accurate, guaranteed global positioning service under civilian control. Currently providing Initial Services, Galileo is interoperable with GPS and Glonass, the US and Russian global satellite navigation systems. By offering dual frequency as standard, Galileo is set to deliver real-time positioning accuracy down

to the metre range. The Galileo constellation in space will comprise 30 satellites in total. There will be 24 operational satellites, plus 6 spare satellites, circulating in medium Earth orbit on three orbital planes.

BEIDOU (China)

BeiDou Navigation Satellite System (BDS) is a Chinese satellite Navigation system. It consists of two separate satellite constellations. The first BeiDou system is officially called the BeiDou Satellite Navigation Experimental System and also known as BeiDou-1.

On December 27, 2018, Beidou-3 officially began to provide global services. The Beidou-3M/G/I satellites represent the orbital segment of the third phase of the Chinese Beidou navigation system which uses satellites in Medium Earth Orbit and Geosynchronous Orbit and is also known as the Compass Navigation Satellite System.

Japan Aerospace Exploration Agency (QZSS Japan)

QZSS is a regional navigation satellite system that provides service to Japan and the Asia-Oceania region. QZSS (nickname of Michibiki - meaning to 'guide' or 'show the way') QZSS is a Japanese satellite positioning system composed mainly of satellites in quasi-zenith orbits (QZO). However, the term “Quasi-Zenith Satellite (QZS)” can refer to both satellites in QZO and geostationary orbits (GEO). For that reason, the name “QZO satellite” is used when it is necessary to specifically refer to satellites in QZO. Satellite positioning systems use satellite signals to calculate position information. The QZSS is sometimes called the “Japanese GPS.”

IRNSS (Indian Regional Navigational Satellite System)

IRNSS is an autonomous regional satellite navigation system being developed by ISRO

(Indian Space Research Organization). It is designed to provide geospatial positioning information within the Indian sub-continent. It enables users to map out their location (altitude, longitude and latitude). The objective of developing IRNSS was to cut down India's dependency on foreign navigation satellite systems.



It provides location information service to users in India and the region extending for up to 1,500 km from the Indian boundary. This is the primary service area of IRNSS information service to users in India and the region extending up to 1500 km from Indian boundary.

IRNSS aims to provide the following services:

1. Standard Positioning Service (SPS) for civilian, research & commercial use,
2. Restricted Service (RS) for authorized users. For example in defence, IRNSS is used for ground, aerial and marine navigation, disaster management, mobile phone integration, mapping and visual & voice navigation for drivers, among others.

Fact File**The battle for the world's fastest supercomputer has a new victor: Summit**

According to IBM, Summit is able to achieve 200 peta flops of performance, or 200 quadrillion calculations per second. This power marks a significant gain on Sunway TaihuLight, which performs a still-staggering 87 petaflops. Summit holds more than 10 peta bytes of RAM, and its funding came as part of a \$325 million program funded by the United States Department of Energy. Each of Summit's 4,608 nodes holds two IBM Power9 chips that run at 3.1 GHz.

Applications of GNSS

GNSS applications are widely used to get the quick information about a particular field. Some of the commercial applications are Consumers, Transportation, GIS, Machine Control Port Automation, Precision Agriculture, Construction, Marine Mining, Unmanned Vehicles Surveying, Defence, and Aerial Photogrammetry, etc.

Consumer

GNSS technology has been adopted by the consumer market, in an ever-increasing range of products. GNSS receivers are now

routinely integrated into smart phones, to support applications that display maps showing the location of and best route to stores and restaurants.

Transportation

In rail transportation, GNSS is used to track the location of locomotives and rail cars, maintenance vehicles and wayside equipment, for display at central monitoring consoles. Knowing the precise location of rail equipment reduces accidents, delays, and operating costs, enhancing safety, track capacity, and customer service. In aviation, GNSS is being used for aircraft navigation from departure, en route, to landing.

Port Automation

Using GNSS, shipping hubs can improve their operating efficiency by tracking the movement and placement of containers about their yards. Many cranes are equipped with GNSS based steering devices that determine the crane's position and keep it travelling in the desired path, improving accuracy and productivity as well as the safety of operators and workers on the ground.



Machine Control

GNSS technology is being integrated into equipment such as bulldozers, excavators, graders, pavers and farm machinery to enhance productivity in the real-time operation of this equipment, and to provide situational awareness information to the equipment operator.



Precision Agriculture

In precision agriculture, GNSS-based applications are used to support farm planning, field mapping, soil sampling, tractor guidance, and crop assessment. More precise application of fertilizers, pesticides and herbicides reduces cost and environmental impact.

Surface Mining

GNSS information is being used to efficiently manage the mining of an ore body and the

movement of waste material. GNSS equipment installed on shovels and haul trucks provides position information to a computer-controlled dispatch system to optimally route haul trucks to and from each shovel.

Survey

Using GNSS, it is possible for a single surveyor to accomplish in one day what might have taken a survey crew of three people a week to complete. Determining a new survey position once required measuring distances and bearings from an existing (known) survey point to the new point.



A-Z GLOSSARY

1. **Microprocessors** - an integrated circuit that contains all the functions of a central processing unit of a computer.
2. **Transponder** - a device for receiving a radio signal and automatically transmitting a different signal.
3. **Lithological** - relating to the general physical characteristics of rocks.
4. **Artificial Intelligence** - development of computer systems able to perform tasks normally requiring human intelligence, such as visual perception, speech recognition, decision-making, and translation between languages.
5. **Digitization** - the conversion of text, pictures, or sound into a digital form that can be processed by a computer.
6. **Geosynchronous** - it is an orbit around Earth of a satellite with an orbital period that matches Earth's rotation on its axis.
7. **Radar** - a system for detecting the presence, direction, distance, and speed of aircraft, ships, and other objects.
8. **Photogrammetry** - the use of photography in surveying and mapping to ascertain measurements between objects.
9. **Automation** - The use of automatic equipment in a manufacturing or other process.
10. **Herbicide** - a substance that is toxic to plants, used to destroy unwanted vegetation.

Exercise



I. Choose the correct answer

1. Which one is wrongly matched?

- | | | |
|------------|---|---------------|
| a) GPS | — | United States |
| b) GLONASS | — | Russia |
| c) GALILEO | — | Japan |
| d) BEODOU | — | China |

2. GPS uses a constellation of

- | | |
|------------------|------------------|
| a) 28 satellites | b) 30 satellites |
| c) 40 satellites | d) 24 satellites |

3. IRNSS provides location information service to users in India and the region extending from the Indian boundary for up to

- | | |
|------------|--------------|
| a) 2300 km | b) 2000 km |
| c) 1000 km | d) 1,500 km. |

4. Match the column – A with column – B and answer using the codes given.

- | A | B |
|----------------------|----------------------------|
| a) First Generation | i) Vacuum Tubes |
| b) Second Generation | ii) Transistors |
| c) Third Generation | iii) Integrated Circuits |
| d) Fourth Generation | iv) Microprocessors |
| e) Fifth Generation | v) Artificial Intelligence |

Codes:

- | 1 | 2 | 3 | 4 | 5 | |
|----|------|------|------|-----|-----|
| a) | i) | ii) | iii) | iv) | v) |
| b) | ii) | i) | iii) | v) | iv) |
| c) | iv) | iii) | v) | ii) | i) |
| d) | iii) | ii) | i) | iv) | v) |

5. Which of the following is not the remote sensing techniques used in the field of geology?

- Lithological mapping
- Structural mapping
- wildlife exploration
- Hydrocarbon exploration

6. Which of the following is not a sun synchronous satellite?

- | | |
|----------------|-------------|
| a) NOAA SEASAT | b) TIROS |
| c) SKYLAB | d) METEOSAT |

7. The wave lengths of the passive remote sensing ranges from
- a) 0.4 to 1.0 mm b) 0.8 to 2.0mm
c) 0.2 to 1.0 mm d) 0.6 to 0.4 mm
8. Which of the following is the fastest computer in the world?
- a) Sunway TaihuLight b) Summit
c) Pratyush d) Param 10000
9. GNSS satellites' orbit is situated about _____ km above the earth's surface
- a) 15,000 km b) 20,000 km
c) 10,000 km d) 22,000 km
10. Which of the following is a geosynchronous satellite?
- a) INTELSAT b) Corona
c) MIDAS d) SAMOS

II. Very short answer

11. Differentiate the active and passive sensors.
12. Write a short note on Galileo GNSS.
13. Name the first GNSS system of the world. What is the name of the GNSS system of India?
14. Write a note on Drone.
15. Write any two services provided by IRNSS.

III. Short answer

16. Mention the three types of satellite's orbit with an example each.
17. Write a note on BeiDou GNSS.
18. Write any three characteristics of spy satellite.
19. Explain in brief about GLONASS.
20. Differentiate geostationary satellite and Sun synchronous satellite.

IV. Detailed answer

21. Explain the elements of remote sensing in detail.
22. Describe any three functions of GIS in detail.
23. Explain the applications of GNSS in the field of surface mining, precision agriculture and port automation.



Reference

- Burrows, William E. *Deep Black: Space Espionage and National Security*. New York: Random House, 1986.
- Fundamentals of Remote Sensing, S. C. Bhatia



ICT CORNER

SATTELITE TRACKER

This activity gives an insight to the students to find out how it Will be in the sapace, how the satellite works, what are Langitudes or latitudes?. This activity gives answer to all these questions .

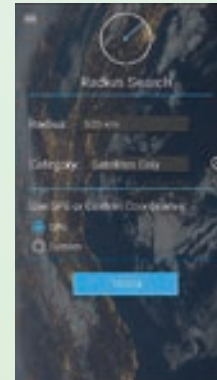

Steps

- Type the URL link given below in the browser or scan the QR code. A page opens with an instruction and four options.
- You can roam around the world with the help of this app.
- Choose one option from the given four. Then play according to the instruction
- In this app radius search and Maps searching working excellently

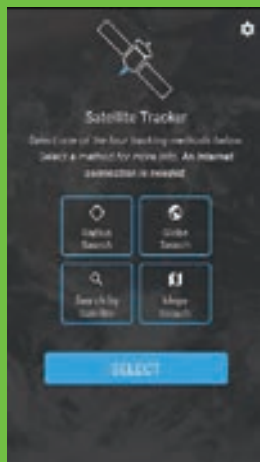

Step 1



Step 2



Step 3

Website URL:

<https://play.google.com/store/apps/details?id=com.trusty.ty.satellite>

*Pictures are indicative only.



UNIT 7

Sustainable Development



Unit Overview

- 7.1 Introduction
- 7.2 Concept and Goals of Sustainable development
- 7.3 Climate Change and Sustainability
- 7.4 Watershed management and its importance
- 7.5 Environmental Impact Assessment
- 7.6 Measures for promotion of sustainable development

7.1. Introduction

In the last few centuries there has been a drastic change in the lifestyle of man. Agricultural growth, industrialization, urbanization, rapid advancement in science and technology have decreased mortality rates and caused rapid growth of population over the earth. With increase in population there is an increase in the demand for natural resources leading to overuse, of nature and its resources. Nations began to wake up to the fact that the earth's resources are depleting at an alarming rate and that something has to be done to sustain them. This led to develop the world in a sustainable way. Sustainability is supported by four pillars which are cultural vitality, economic health, environmental responsibility and social equity. All nations in the world focus on sustainable development as a major task.



Learning Objectives

- To describe the importance of Sustainable Development.
- To highlight the interconnectivity between man, environment and economic growth.
- To understand the United Nations Sustainable Development Goals.
- To underline individual's role in creating a sustainable earth.



United Nations and Sustainable Development

Sustainability was first featured in the principles adopted by the United Nations Conference on the Human Environment held at Stockholm on 16 June 1972. It was now realized that development needed to be sustainable – it should not only focus on economic and social matters, but also on matters related to the use of natural resources. The United Nations commissioned a group of 22 people from both developed and developing countries to identify long-term environmental strategies for the international community. This World Commission on Environment and Development (WCED), was headed by Gro Harlem Brundtland, then the Prime Minister of Norway. This commission came

to be known as the **Brundtland Commission**, which submitted its report, entitled *Our common future*, to the UN in 1987.

The Brundtland Report focused on the needs and interests of humans. It was concerned with securing a global equity for future generations by redistributing resources towards poorer nations to encourage their economic growth in order to enable all human beings to achieve their basic needs. The report highlighted the three fundamental components of sustainable development, the environment, the economy, and society, which later became known as **the triple bottom line**.

The 1992 and 2002 Earth Summits held at Rio de Janeiro and Johannesburg were the United Nations Conference on Environment and Development (UNCED), a direct result of the Brundtland Commission. An important achievement of the Rio summit was an agreement on the Climate Change Convention which led to the Kyoto Protocol.

The United Nations Conference on Sustainable Development (UNCSD), also known as **Rio 2012, Rio+20 or Earth Summit 2012** was the third and recent International conference on sustainable development. It was hosted by Brazil in Rio de Janeiro from 13 to 22 June 2012.

7.2 Concept and Goals of Sustainable Development

In 1980 the International Union for the Conservation of Nature introduced the term "sustainable development". Sustainable development is development that meets the needs of the present without compromising the ability of future generations to meet their own needs.

A primary goal of sustainable development is to achieve a reasonable and equitably distributed level of economic wellbeing that can be continued for many human generations.

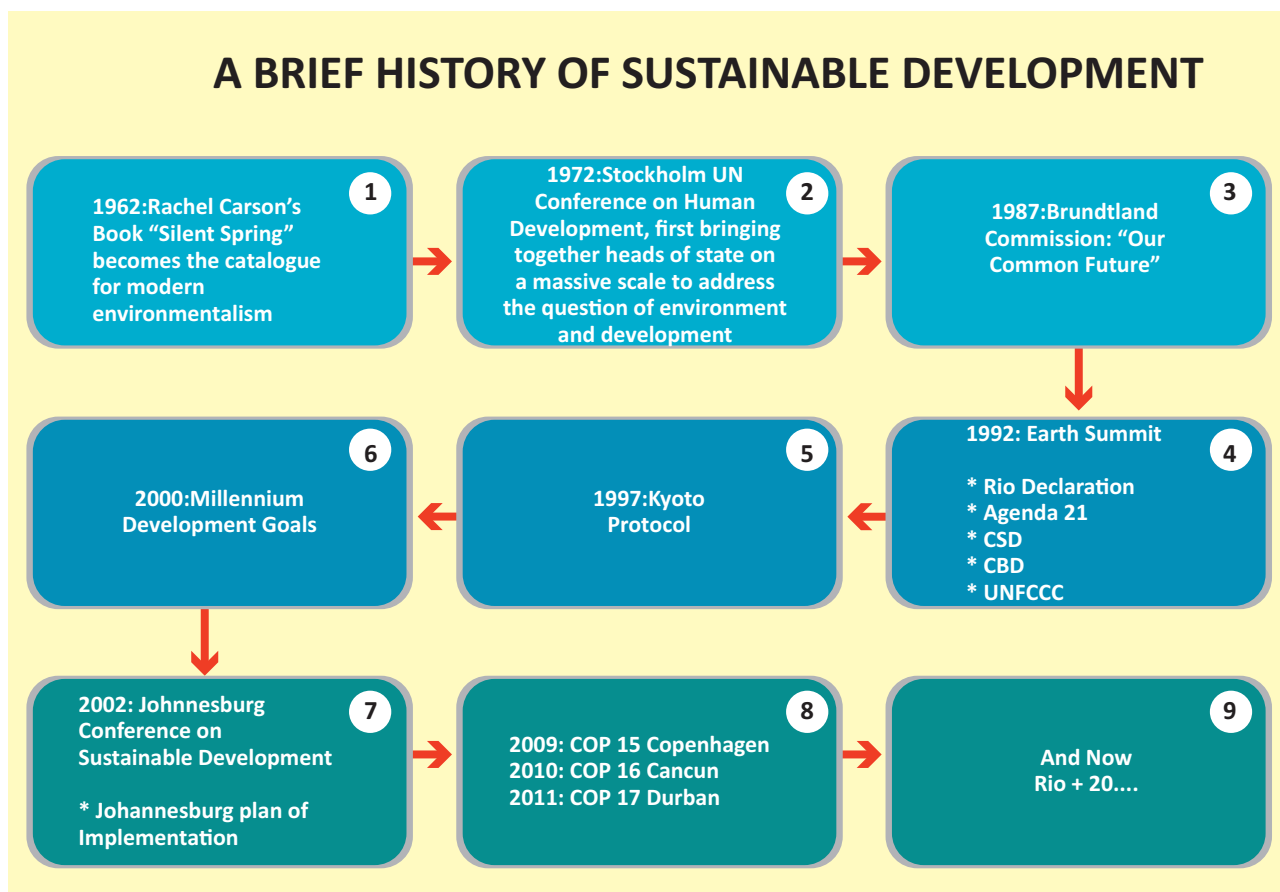

Sustainable Development Goals (SDGs)

In 1992, the UN Conference on Environment and Development published the Earth Charter, which outlined the building of a just, sustainable, and peaceful global society in the 21st century. The action plan was known as 'Agenda 21' for sustainable development.

In September 2015, the United Nations General Assembly formally adopted the "Universal, integrated and transformative"

2030 Agenda for Sustainable Development, a set of 17 Sustainable Development Goals (SDGs). The goals are to be implemented and achieved in every country from the year 2016 to 2030.

Countries adopted a set of goals to end poverty, protect the planet and ensure prosperity for all as part of a new sustainable development agenda. Each goal has specific targets to be achieved over the next 15 years.

For the goals to be reached, everyone needs to do their part: governments, the private sector, civil society and people.



Goal 1: End poverty in all its forms everywhere

One in five people in developing countries still live on less than \$1.90 a day, many people risk slipping back into poverty. Economic growth must be inclusive to provide sustainable jobs and promote equality.

Goal 2: End hunger, achieve food security and improved nutrition and promote sustainable agriculture

Agriculture, forestry and fisheries can provide nutritious food for all and generate decent incomes, while supporting people-centred rural development and protecting the environment. A profound change of the global food and agriculture system is needed if we are to nourish today's 815 million hungry and the additional 2 billion people expected by 2050.

Goal 3: Ensure healthy lives and promote well-being for all at all ages

Significant strides have been made in increasing life expectancy and reducing some of the common killers associated with child and maternal mortality. Major progress has been made on increasing access to clean water and sanitation, reducing malaria, tuberculosis, polio and the spread of HIV/AIDS.

Goal 4: Ensure inclusive and quality education for all and promote lifelong learning

Major progress has been made towards increasing access to education at all levels and increasing enrolment rates in schools particularly for women and girls. For example, the world has achieved equality in primary education between girls and boys, but few countries have achieved that target at all levels of education.

Goal 5: Achieve gender equality and empower all women and girls

Gender equality is not only a fundamental human right, but a necessary foundation for a peaceful, prosperous and sustainable world.

Goal 6: Ensure access to water and sanitation for all

Clean, accessible water for all is an essential part of the world we want to live in. There is sufficient fresh water on the planet to achieve this. But due to bad economics or poor infrastructure, every year millions of people, most of them children, die from diseases associated with inadequate water supply, sanitation and hygiene. By 2050, at least one in four people is likely to live in a country affected by chronic or recurring shortages of fresh water.

Goal 7: Ensure access to affordable, reliable, sustainable and modern energy for all

Energy is central to nearly every major challenge and opportunity the world faces today. Sustainable energy is opportunity – it transforms lives, economies and the planet.

Goal 8: Promote inclusive and sustainable economic growth, employment and decent work for all

Sustainable economic growth will require societies to create the conditions that allow people to have quality jobs that stimulate the economy while not harming the environment. Job opportunities and decent working conditions are also required for the whole working age population.

Goal 9: Build resilient infrastructure, promote sustainable industrialization and foster innovation

Inclusive and sustainable industrial development is the primary source of income generation, allows for rapid and sustained increases in living standards for all people, and provides the technological solutions to environmentally sound industrialization.

Goal 10: Reduce inequality within and among countries

To reduce inequality, policies should be universal in principle paying attention to the needs of disadvantaged and marginalized populations.

Goal 11: Make cities inclusive, safe, resilient and sustainable

Cities are hubs for ideas, commerce, culture, science, productivity, social development and much more. At their best, cities have enabled people to advance socially and economically. Common urban challenges include congestion, lack of funds to provide basic services, a shortage of adequate housing and declining infrastructure.

Goal 12: Ensure sustainable consumption and production patterns

Sustainable consumption and production is about promoting resource and energy efficiency, sustainable infrastructure, and providing access to basic services, green and decent jobs and a better quality of life for all. Its implementation helps to achieve overall development plans, reduce future economic, environmental and social costs, strengthen economic competitiveness and reduce poverty.

Goal 13: Take urgent action to combat climate change and its impacts

Climate change is now affecting every country on every continent. It is disrupting national economies and affecting lives, costing people, communities and countries dearly today and may be even more tomorrow.

Goal 14: Conserve and sustainably use the oceans, seas and marine resources

The world's oceans – their temperature, currents and life – drive global systems that make the earth habitable for humankind. Careful management of this essential global resource is a key feature of a sustainable future.

Goal 15: Sustainably manage forests, combat desertification, halt and reverse land degradation, halt biodiversity loss

Forests cover 30 per cent of the Earth's surface and in addition to providing food security and shelter, forests are key to combating climate change, protecting biodiversity and the homes of the indigenous population. Thirteen million hectares of forests are being lost every year while the persistent degradation of dry lands has led to the desertification of 3.6 billion hectares.

Goal 16: Promote just, peaceful and inclusive societies

This Goal is dedicated to the promotion of peaceful and inclusive societies for sustainable development, the provision of access to justice for all, and building effective, accountable institutions at all levels.

Goal 17: Revitalize the global partnership for sustainable development

A successful sustainable development agenda requires partnerships between governments, the private sector and civil society. These inclusive partnerships built upon principles and values, a shared vision, and shared goals that place people and the planet at the centre, are needed at the global, regional, national and local level.

Fact File

Paris Agreement

To address climate change, countries adopted the **Paris Agreement** at the COP21 in Paris on 12 December 2015. The Agreement entered into force shortly thereafter, on 4 November 2016. In the agreement, all countries agreed to work to limit global temperature rise to well below 2°C, and given the grave risks, to strive for 1.5°C.

7.3 Climate Change and Sustainability

The Earth's climate has changed throughout history. In the last 650,000 years there have been several cycles of glacial and warm periods each lasting thousands or millions of years. Most of these climate changes are attributed to very small variations in earth's orbit that changes the amount of solar energy our planet receives. It is understood that at present the Earth's climate is getting warmer which is referred to as 'Global Warming'. Earth's temperature has gone up about one degree Fahrenheit in the last 100 years. This is a very small change but small changes in earth's temperature can have big effects. Some effects are already happening such as melting of glaciers, rise in the level of oceans, prolonged droughts, excessive rain and floods, etc.

Reasons for Climate change

Burning fossil fuels emits gases into the atmosphere. Burning fossil fuel to provide energy, coupled with the effects of major transportation and deforestation causes a rapid increase in global temperatures. This can change the climate of a place.

Effects of climate change – Scientists had predicted in the past that the result from global climate change are now occurring, loss of sea



United Nations Frame work Convention on Climate Change (UNFCCC) Process for Climate Change Adaptation, On 17, May 2017: Policy makers, implementers, supporters and investors from all over the world met during the UNFCCC Bonn Climate Change Conference at the Technical Expert Meeting (TEM) on Adaptation to discuss 'Integrating climate change adaptation with the Sustainable Development Goals and the Sendai Framework for Disaster Risk Reduction.

ice, accelerated sea level rise and longer, more intense heat waves.

1. **Temperatures will continue to rise** - Experts agree that greenhouse gases which trap heat and prevent it from leaving the earth's atmosphere are mostly responsible for the temperature spike.
2. **Frost-free season (and growing season) will lengthen** - it could actually have detrimental effects on the crops we grow. Warmer weather helps pests survive longer which can destroy crops. Rising temperatures are also expected to contribute to a shift in areas which are agriculturally most productive and the crops that grow there.
3. **Changes in precipitation patterns** - The contrast between wet and dry areas will increase globally. In other words, the wet areas will get wetter and the dry areas will get drier.
4. **More droughts and heat waves** - With rising temperatures and shifting rainfall patterns, heat waves and droughts are increasing in frequency and intensity.
5. **Sea level rise** - Scientists have determined that global sea level has been steadily rising since 1900 at a rate of at least 0.1 to 0.25 centimeter per year. Sea level can rise by two different mechanisms with respect to climate change.
6. **Arctic likely to become ice-free** - The Arctic Ocean is expected to become essentially ice free in summer before mid-century.

Response to Climate Change

There are two main responses to climate change.

1. **Mitigation** - which addresses the root causes of climate change, by reducing greenhouse gas emissions.

2. **Adaptation** - seeks to lower the risks posed by the consequences of climatic changes. Both approaches will be necessary to deal with the global changes that have already been set in motion.

Mitigation measures:

It is important that we learn how to reduce climate change, and put them into practice now, before it is too late.

1. **Cleaner alternative energy sources:** One important way to fight climate change is to reduce our reliance on and usage of fossil fuels, and depend on alternative renewable and greener sources of energy such as wind energy, solar energy, water or hydropower, biomass, and geothermal energy.
2. **Energy saving tips** - we can adopt energy saving tips by investing in more expensive energy-saving appliances like the compact fluorescent light (CFL) bulbs, Air-conditioners, refrigerators etc. Switching off our electrical appliances when not in use.
3. **Green driving tips** - The best strategy to reduce toxic gas emissions is definitely to reduce the use of automobiles. Use public transport, carpooling, use of electricity powered cars or two wheelers can be an alternative.
4. **Reduce - Reuse - Recycle practices** - Reducing, reusing and recycling helps us conserve resources and energy, and reduce pollution and greenhouse gas emissions produced thereby.
5. **Re-forestation** - The cleanest and most efficient remover of carbon dioxide from our atmosphere actually is nothing but green plants and trees. The rate at which we are cutting down our trees and forests to make way for human developments has greatly reduced the earth's ability to remove carbon dioxide from the atmosphere.

6. **Organic farming** - Soils are an important sink for atmospheric carbon dioxide. Nevertheless, deforestation making way for conventional agriculture is increasingly depleting this sink. Sustainable and organic agriculture helps to counteract climate change by restoring soil organic matter content as well as reduce soil erosion and improve soil physical structure. Organic farming uses natural fertilizers and helps maintain crop yields.

7.4 Watershed management and its importance

Watershed is a geographical area drained by a stream or a system connecting stream in which water from all over an area flow under gravity to a common drainage channel. A watershed system delivers water through rills, gullies and streams to a larger body of water.

Watershed management is proper utilization of land and water resource for optimum production with minimum hazards to natural resources. It relates to soil and water conservation proper land uses, promote afforestation and sustainable farming practices, conserve farmland and pastureland, maintaining soil fertility, proper management of local water for farming, drainage, construct small dams for flood protection, improving individuals standard of living and thereby promote ecological balance.

Key steps in watershed management

Watershed plans should first identify the characteristics of the watershed and inventory the watershed's natural resources. The first steps in watershed management planning are to:

- i) Delineate and map the watershed's boundaries and the smaller drainage basins within the watershed.
- ii) Map and prepare an Inventory of resources in the watershed.

- iii) Prepare an Inventory and map the natural and manmade drainage systems in the watershed.
- iv) Prepare an Inventory and map land use and land cover.
- v) Prepare a soil map of the watershed.
- vi) Identify areas of erosion, including stream banks and construction sites.
- vii) Identify the quality of water resources in the watershed as a baseline; and

Watershed Management in India:

Watershed development project in the country has been sponsored and implemented by Government of India from early 1970s onwards. Various watershed development programs like Drought Prone Area Program (DPAP), Desert Development Program (DDP), River Valley Project (RVP), National Watershed Development Project for Rain-fed Areas (NWDPA) and

Integrated Wasteland Development Program (IWDP) were launched subsequently in various hydro-ecological regions. Entire watershed development programs primarily focused on soil conservation and rainwater harvesting during 1980s and before.

Rain Water Harvesting (RWH)

Millions of people throughout the world do not have access to clean water for domestic purposes. In many parts of the world conventional piped water is either absent, unreliable or too expensive. One of the biggest challenges of the 21st century is to overcome the growing water shortage. Rain Water Harvesting (RWH) has thus regained its importance as a valuable alternative or supplementary water resource, along with more conventional water supply technologies. Water shortages can be relieved if rain water harvesting is practiced more widely.

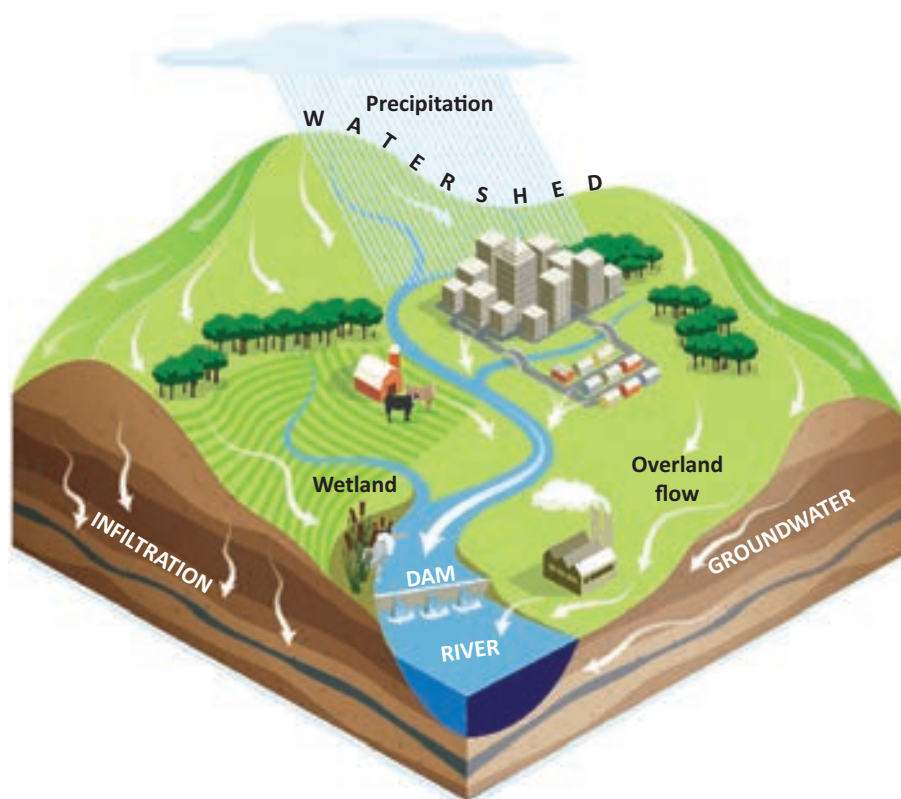

Need for Rain Water Harvesting

- i) To overcome the situation of inadequacy of water supply.
- ii) The most economical way to increase the ground water table.
- iii) To replenish the sub soil of the urban area covered with pavements.
- iv) To recharge the underground water table at places where the availability of rain water is higher or to overcome the situation of water logging.
- v) Rain water harvesting also improves the quality of underground water through a process called dilution.
- vi) To get water for irrigation of greenbelts, farms, gardens, etc.

Rain Water Harvesting Techniques

There are two main techniques of rain water harvestings:

- 1) Storage of rain water on surface for future use.
- 2) Recharge to ground water.

The storage of rain water on surface is a traditional technique and structures used were underground tanks, ponds, check dams, weirs, etc. Recharge of ground water is a new concept of rain water harvesting and the structures generally used are: Recharge pits filled with boulders, gravels, and coarse-sand, Wells, Trenches etc.

7.5 Environmental Impact Assessment

Every country strives to progress ahead. One aspect of progress is economic development through manufacturing and trading. Every country builds industries which provide employment, serve the consumers needs and help to generate revenue. The dominant pattern of development that humankind has

followed in recent decades has brought about large scale changes in the earth systems. We are already feeling the impact of these changes upon our health, livelihoods and safety. On the other hand, the fruits of development are not equally distributed. Some countries and some communities have a high standard of living, while others are not able to meet their basic needs.

Development projects in the past were undertaken without any consideration about their environmental consequences. As a result rivers and lakes have been polluted, air pollution has reached threatening levels and piling of domestic and industrial wastes has resulted in land degradation. Industrialization and economic growth provided material comforts but at the same time deteriorated the quality of life.

The Objective of EIA

- (i) To identify, predict and evaluate the economic, environmental and social impact of development activities
- (ii) To provide information on the environmental consequences for decision making and
- (iii) To promote environmentally sound and sustainable development through the identification of appropriate alternatives and mitigation measures.

Steps in the EIA Process

The eight steps of the EIA process:

- i) **Screening:** First Stage of EIA, which determines whether the proposed project, requires an EIA and if it does, then the level of assessment required.
- ii) **Scoping:** This stage identifies the key impacts that should be investigated. This stage also defines the time limit of the study.
- iii) **Impact analysis:** This stage of EIA identifies and predicts the likely environmental and

social impact of the proposed project and evaluates the significance.

- iv) **Mitigation:** This step in EIA recommends the actions to reduce and avoid the potential adverse environmental consequences of development activities.
- v) **Reporting:** This stage presents the result of EIA in a form of a report to the decision-making body and other interested parties.
- vi) **Review of EIA:** It examines the adequacy and effectiveness of the EIA report and provides the information necessary for decision –making.
- vii) **Decision-making:** It decides whether the project is rejected, approved or needs further change.
- viii) **Post monitoring:** This stage comes into play once the project is commissioned. It checks to ensure that the impacts of the project do not exceed the legal standards and implementation of the mitigation measures are in the manner as described in the EIA report.

Environmental Impact Assessment in India

EIA was introduced in India in 1978, with respect to river valley projects. On 27 January 1994, the Union Ministry of Environment and Forests (MEF), Government of India, under the Environmental (Protection) Act 1986, made Environmental Clearance (EC) mandatory for expansion or modernisation or for setting up new projects listed in Schedule 1 of the notification. Since then there have been 12 amendments made in the EIA notification of 1994. Both central and state authorities share the responsibility of EIA's development and management. EIA is now mandatory for 30 categories of projects, and these projects get Environmental Clearance (EC) only after the EIA requirements are fulfilled.

The MoEF recently notified new EIA legislation in September 2006. The notification makes it mandatory for all projects to get environment clearance from the central government under the following categories:

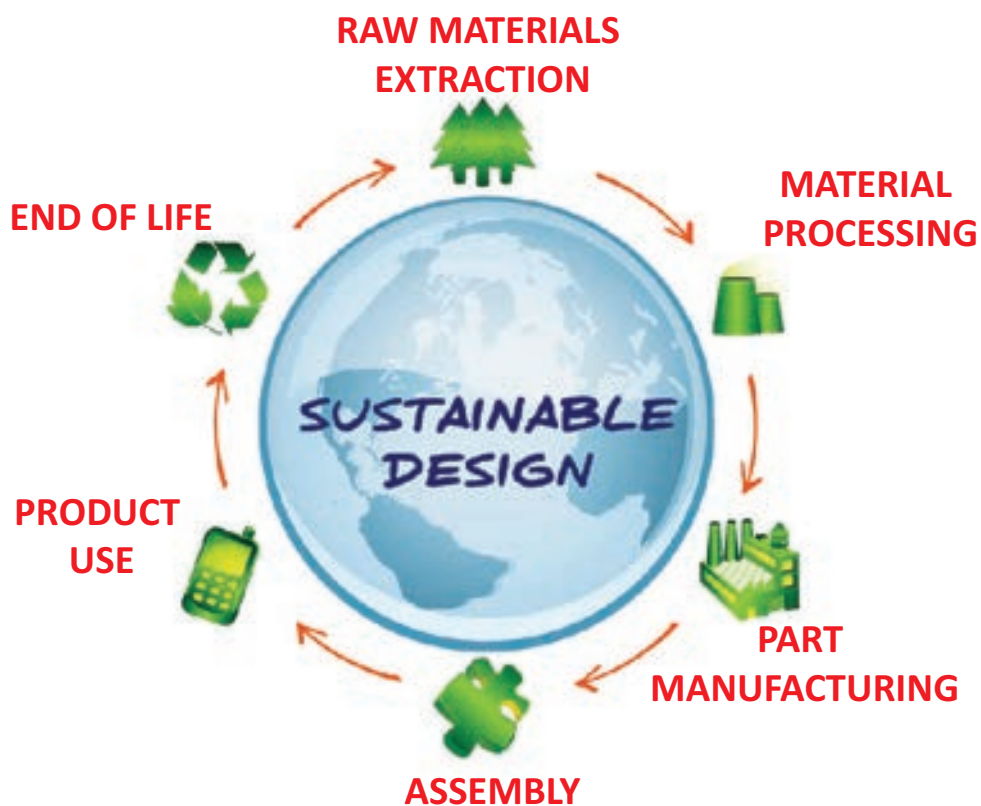

- (1) Industries
- (2) Mining
- (3) Thermal power plants
- (4) River valley projects
- (5) Infrastructure and CRZ
(Coastal Regulation Zone)
- (6) Nuclear power projects.

However, the new legislation has entrusted the decision of clearing projects on the state government depending on the size/capacity of the project. EIA appraises the environmental health and social implications of planned developmental projects. It thus links environment with development. The goal of EIA is to ensure environmentally safe and sustainable development.

7.6 Measures for Promotion of Sustainable Development

As discussed earlier, the United Nations 17 Sustainable Development Goals and 169 targets are part of the 2030 Agenda for Sustainable Development adopted by 193 Member States at the UN General Assembly Summit in September 2015, and which came into effect on 1 January 2016. These goals are the result of international consultations that brought national governments and millions of citizens from across the globe together to negotiate and adopt the global path to sustainable development for the next 15 year.

The SDGs and targets will stimulate action in the following critically important areas: poverty, hunger, education, health and well-being, education, gender equality, water and sanitation, energy, economic growth and decent work, infrastructure, industry and innovation, reducing inequalities, sustainable cities, consumption and production, climate action, ecosystems, peace and justice, and partnership. This agenda recognises that it is not enough to focus on economic growth alone but in creating more equal societies, and a safer and more prosperous planet.

CASE STUDY

Baripada: A hamlet that conserves forest, promotes growth



Baripada, a small hamlet straddling the Maharashtra-Gujarat border, is a collective tribal wisdom which has taken it to the next level. With a population of barely 1,000, the village has not only helped conserve their forest but also meet the United Nations' sustainable development goals, benefiting everyone in the process.

The villagers conserved the forest. And, forest helped in conservation of water. Water enabled agriculture and farming. Farming brought prosperity, which in turn helped improve literacy. And, literacy broadened horizons and led us to total transformation.

Having developed dairy and poultry over the years, the villagers have also evolved a system for marketing their products. This ensured a steady flow of revenue and kept poverty at bay. The villagers share their common land with landless families to ensure 'zero hunger' and 'reduction of inequality'.

Besides, the villagers are game for any experiments involving water, land, forest conservations, biodiversity registration, biogas, solar power, building basic infrastructure through public participation. "Decisions on prohibition, tree plantation were made at the village meeting and immediately implemented. But, to restrict entry of humans and animals in the 445 hectares of village forest was a major task".

Which countries are achieving the UN Sustainable Development Goals fastest?

The ultimate aim of the Sustainable Development Goals is to end poverty, protect the planet and ensure prosperity for everyone. Each goal has specific targets that need to be met by 2030.

So how close are countries to meeting them? To find out, non-profit organization Bertelsmann Stiftung and the UN Sustainable Development Solutions Network have created a prototype index that measures their performance.

Sweden leads the list, followed by Denmark and Finland. Among the G7

countries, only Germany and France can be found among the top ten performers. The United States ranks 42nd on the Index, while Russia and China rank 62nd and 71st respectively. Also in the top 20 were Canada (13th), the Czech Republic (15th) and Slovenia (17th). Asia-Pacific's top performers Japan, Singapore and Australia rounded off the list at 18th, 19th and 20th, respectively. The SDG Index underlines that despite achieving high percentages, all countries still have their work cut out to close the remaining gap.

India ranks 116 out of 157 nations on a global index that assesses the performance of countries towards achieving the ambitious sustainable development goals (SDGs).

A-Z GLOSSARY

- 1. Coastal Zone:** The area that extends from the high tide mark on land to the edge of the continental shelf, which is the submerged part of the continent.
- 2. Earth Summit:** The high level inter-governmental meeting on environment of the earth held in Rio-de-Janeiro, Brazil in June 1992.
- 3. Global Warming:** The slow gradual rise in the temperature of the earth due to emission of excess quantities of radiation-trapping gases.
- 4. Local Authority:** An official body responsible to a higher body doing some of the administrative and welfare work of the locality e.g., Panchayats.
- 5. Health:** The condition in which the body is sound and the mind is free,
- 6. Aerosol:** Fine liquid, solid or gas particulates that remain suspended in the atmosphere for varying periods.
- 7. Logging:** Activity of felling trees and preparing the timber.
- 8. Gully:** A ravine formed by the action of water.
- 9. Biomass:** Organic matter used as fuel specially in a power station for the generation of electricity.

Exercise

I. Choose the correct Answer



1. **Who headed the World Commission on Environment and Development?**
 - a) George Perkins Marsh's
 - b) Gro Harlem Brundtland
 - c) Edward Goldsmith's
 - d) Fruitz Schumacher's
2. **Sea level rise is occurring steadily at the rate of _____ per year**
 - a) 0.01 to 0.25 centimetre
 - b) 0.1 to 0.25 centimetre
 - c) 0.1 to 0.025 centimetre
 - d) 1 to 0.25 centimetre
3. **Rain water harvesting improves the quality of _____ water.**
 - a) Sea
 - b) Ocean
 - c) River
 - d) Under ground
4. **which is the best strategy to reduce toxic gas emissions.**
 - a) Public motor transport
 - b) Use private transport
 - c) Use of electricity powered cars
 - d) Two wheelers can be an alternative
5. **In which year was EIA introduced in India**
 - a) 1947
 - b) 1950
 - c) 1956
 - d) 1978
6. **Expand the term UNFCCC**
 - a) United Nations Forum on Climate Change Council
 - b) United Nations Framework Convention on Climate Change
 - c) United Nations Framework Conveyance on Climate Change
 - d) United Nations Forum Conveyance on Climate Change
7. **Reducing inequality within and among countries fall under sustainable development**
 - a) Goal 10
 - b) Goal 7
 - c) Goal 15
 - d) Goal 5
8. **The United Nations 17 Sustainable Development Goals and 169 targets are part of the 2030 Agenda for Sustainable Development adopted at the UN General Assembly Summit in September 2015 by**
 - a) 183
 - b) 193
 - c) 173
 - d) 163
9. **The International Union for the Conservation of Nature introduced the term "sustainable development in**
 - a) 1990
 - b) 1980
 - c) 1970
 - d) 1960

10. In the Paris Agreement at the COP21 in Paris on 12 December 2015 all countries agreed to work to limit global temperature rise to

- Below 2 degrees Celsius,
- Above 2 degrees Celsius
- Between 2 degrees Celsius and 4 degrees Celsius
- Between 2 degrees Celsius and 6 degrees Celsius

II. Very short answers

- What did the Brundtland Report Highlight?
- Explain Goal 15 in sustainable development.
- What are the two main techniques of rain water harvesting?
- Expand and define the term EIA.

III. Short answers

- What is meant by 'Sustainable Development'? State any two primary goals of sustainable development?
- State any three reasons for climate change.
- Write a note on organic farming.
- Write any three statements on the need for rain water harvesting.
- Name six countries achieving sustainable goals the fastest.

IV. Detailed answers

- Explain the Environmental Impact Assessment in India.
- Describe the effects of climate change.
- Explain the process used in the environmental component of EIA?

V. Practice

Project :1.Study of your local area.

- Draw a rough map of your neighbourhood (villages, ward, town).
- Get the information about your local area in the past through the older family members or neighbours.
- Compare it with the present rough map
- Write a short note on those areas in your locality that require sustainability.



Reference

- Environmental Impact Assessment, Larry W. Canter



Web reference

- <https://www.youtube.com/watch?v=3WODX8fyRHA#action=share>
- <https://www.youtube.com/watch?v=g75FRAF6wlc>



ICT CORNER

SUSTAINABILITY

This activity enables the students to understand about the need to sustain our natural resources. It helps them to understand more about how to use the three Rs to maintain the given resources



Steps

- Type the URL link given below in the browser or scan the QR code. A page opens with two options . **“Instructions and Play game”**
- Read the instruction well before start to play
- Many objects will appear on the screen you have to collect it with the help of the toy on the screen and classify it .
- Then you have to put it in the three bins according to the instructions.
- The time limit is two minutes only. At the end of the game you will see your score.



Step 1



Step 2

Website URL:

<http://images.nationalgeographic.com/wpf/media-content/richmedia/1/1143/project/dist/desktop.html>

*Pictures are indicative only.



UNIT 8

Man-Made Disasters - Public Awareness For Disaster Risk Reduction



Learning Objectives

- Understand the community based Disaster Risk Reduction approaches.
- List out the important man-made disasters.
- Describe the rules of action during stampede.
- State how to protect one -self from drowning.
- Explain the measures of how to prevent fire accident
- Elucidate the rules of action for transport accident.



Unit Overview

- 8.1 Introduction
- 8.2 Community based Disaster Risk Reduction
- 8.3 Man - made disasters
 - 8.3.1 Stampede
 - 8.3.2 Drowning
 - 8.3.3 Fire Accident
 - 8.3.4 Industrial Disasters
 - 8.3.5 Road Accident

8.1. Introduction

"Mumbai railway station stampede kills at least 22"

"Rush-hour crush on footbridge connecting two stations was triggered by falling concrete that caused panic!"

At least 22 people have been killed and more than 30 injured during a rush-hour stampede on a bridge between two railway stations in Mumbai. The crush occurred on a narrow footbridge connecting Prabhadevi station, formerly Elphinstone, and Parel station during the Friday, September 29, 2017 morning commuter rush and amid heavy rain. "There was a huge crowd on the foot over bridge. Everybody tried to leave at once and it appeared one of them slipped and fell, triggering the stampede," said an Indian Railways spokesman. Another spokesman said the number of people on the bridge was higher than usual because people were using the station to shelter from the rain.

The above incident throws some lights on how to be aware of the accidents we encounter in our daily walk of life. Let us try to answer the following questions:

1. Which is more important life or the scheduled journey to be completed?
2. Why rushing in anything may be disastrous?
3. Why timely communication is more important to avoid accident?

The root of the word disaster ("bad star" in Greek and Latin) comes from an astrological theme in which ancients used to refer to the destruction of a star as a disaster.

Terms to know:

1. Hazard is a potentially damaging physical event or human activity which may cause the loss of life or injury, property damage, social and economic disruption or environmental degradation.
2. Disaster is a serious disruption of a society functioning, causing widespread human, material losses which exceed the ability of the affected society to cope using its own resources.
3. Disaster risk management is a set of activities, including structural and non-structural measures to avoid (prevention) or to limit (mitigation and preparedness) adverse effects of disaster.
4. Capacity - the assets, resources and skills available within a community that can be used to reduce the risks or effects of a disaster.
5. Disaster risk reduction includes activities that will minimize disaster-related losses of life and property.

Disaster is a serious disruption, causing damage or injury to people, buildings, roads, livelihoods, or the environment, which exceed the community's ability to cope.

The magnitude and impact of disasters are increasing and disasters have disrupted social, economic and environmental community activities worldwide. International data shows that disasters have taken, over the last 10 years, more than 478,000 lives. It has affected 2.5 billion people and caused direct economic losses in the amount of 690 billion US dollars worldwide.

Recent financial studies underline the urgent need for a shift from sole disaster response to disaster risk reduction. Therefore, efforts should be made to ensure that disaster risk reduction is an important aspect of poverty

reduction and general development initiatives in the coming years.

8.2 Community-Based Disaster Risk Reduction

Community is a group of people living in the same place having homogenous characteristics. It includes shared experiences, locality, culture, language and social interests. Community-based disaster risk reduction is a process within a community and for the community. Reducing risk in communities should address the root causes of risks and address it through local knowledge and expertise. Performance and the arts provide a variety of creative opportunities to communicate. Important messages through live experiences. Examples include: Street theatre, dramatic readings, skits and plays, puppet shows, poetry reading.

Dance, flash mob activities in large urban settings (a group of people who assemble suddenly in a public place, perform an unusual act and then disperse), tapping into oral traditions such as story-telling, music and sing-along, mural-making and other hands-on art and design activities. All of these can involve volunteers and community members, as performers and audiences. Skilled performers find creative ways to engage their audience.

8.3 Man - made Disasters

Disasters induced by human beings are man-made disasters. It includes fire accident, transport accident, structure failure, mining accidents, explosions, stampede etc. In this lesson, we study about some of the man-made disasters.

8.3.1 Stampede

The term stampede is a sudden rush of a crowd of people, usually resulting in injuries and death from suffocation and trampling. In stampede, the term mob or crowd is used to refer to a congregated, active, polarized aggregate

of people, which is basically heterogeneous and complex. Its most salient features include homogeneity of thought and action among its participants and their impulsive and irrational actions.

Causes of stampede

Incidents of stampedes can occur in numerous socio-cultural situations. These stampede incidents can be categorized into the following types: Entertainment events, escalator and moving walkways, food distribution, processions, natural disasters, power failure, religious events, fire incidents during religious/ other events, riots, sports events and weather related events.



Large religious gatherings are the major stampede events in developing countries like India. As stated in a newspaper in 2013, 79 percent of stampedes in India have taken place at religious events.

Stampede Management

Crowd management is defined as the systematic planning and supervision of the orderly movement and assembly of people. Crowd control is the restriction or limitation of group behavior.



The rules of action for stampede

1. Notice Alternate Exit: First thing to know in such situations is the route out. If you are attending an event, one of the things you

can do in preparation is to try and know the topography of the place. This will help you find the exits. So, when struck in a stampede, try to identify these exits.



2. Keep Your Hands by Your Chest: Your hands must be up by your chest like they would be in a boxing position. This makes it easy to move. It also stops your ribs from getting crushed by the crowd on both sides. When the crowd pushes you from front and back, your lungs will be affected. You will suffer of suffocation.



3. How to move when on your feet: In the middle of a moving crowd, do not resist the flow by standing still or sitting down. The force is too much to fight. Like in a wave, there is force and in crowd situation. Keep moving diagonally between the pockets of people whenever there is a lull. Try to move towards the exits but not towards walls or fences where you might be cornered. Keep moving with the crowd to avoid falling.



4. How to move if you fall: If you fall and get back on your feet, cover your head with your hands and hurl up in a fetal position. Basically, avoid exposing your lungs to the crowd. Keep trying to find an opportunity to get up.



5. Communicate smartly: When trapped in the crowd, use sign language such as waving your hands up one side after another so that you will not get exhausted.

6. Conserve energy: Keep calm and do not try to scream. That only increases panic.

7. Set a meeting place: Arrange a meeting place, in case you get separated, one inside and another one outside.

If someone extends his/her hand for help, grab hold to keep them up.

Child safety Tips: Take a second, take a photo.

Before taking children out to any event, pull out your phone and take a photo of each child individually a selfie. That way you have a picture of how they looked that day. The photo can be sent to police to aid in locating the child in case the child is lost in a crowd.

8.3.2 Drowning

Drowning is the 3rd leading cause of unintentional injury death worldwide, accounting for 7% of all injury-related deaths. There are an estimated 3,72,000 annual drowning deaths worldwide. Children, males and individuals with increased access to water are most at risk of drowning. Drowning is the process of experiencing respiratory impairment from submersion/immersion in liquid; outcomes are classified as death, morbidity and no morbidity.

Fact File

It is one of our most visceral fears; thrashing in the deep, far below the water's surface, lungs burning for oxygen. Drowning claims hundreds of thousands of lives every year, a great many of whom are young children. Of course, exposure to water is a key factor in drowning, but there is a strong economic correlation as well. Those in poorer countries are far more likely to be drowning. In Bangladesh, 17,000 children drown annually that's 46 a day.

Fresh Water and Salt Water Drown You Differently.

Fact File continue



At first glance, it would appear that swimming in the ocean is far more dangerous than swimming in a lake. Crashing waves and riptides can easily sweep beachgoers to their doom. But shockingly enough, about 90 percent of drowning cases occur in freshwater. The reason involves a bit of chemistry. Fresh water is more similar in composition to our own blood than salt water. When it is inhaled into the lungs, it passes into the bloodstream through osmosis. When the blood is so radically diluted, cells burst, leading to organ failure. The entire process takes two to three minutes.

Ocean water contains far more salt than human blood. When it is aspirated, the body attempts to regulate itself by transferring water into the lungs, thickening the blood. It takes considerably longer to kill a person, between 8 to 10 minutes, allowing a much greater chance of rescue.

Males are especially at risk of drowning, with twice the overall mortality rate of females. Studies suggest that the higher drowning rates among males are due to increased exposure to water and riskier behavior such as swimming alone, drinking alcohol before swimming alone and boating. Drowning accounts for 75% of deaths in flood disasters.

Prevention

There are many actions to prevent drowning. Installing barriers (e.g. covering wells, using doorway barriers and playpens, fencing swimming pools etc.) to control access to water hazards.

Community-based, supervised child care for pre-school children can reduce drowning risk. Teaching school-age children basic swimming, water safety and safe rescue skills is another approach.

Setting and enforcing safe boating, shipping and ferry regulations is an important part of improving safety on the water and preventing drowning. Building resilience to flooding and managing flood risks through better disaster preparedness planning, land use planning, and early warning systems can prevent drowning during flood disasters.

8.3.3 Fire Accident

Massive forest fires may start in hot and droughty weather as a result of lightning, and human carelessness or from other causal factors. Fires can lead to the destruction of buildings, wooden bridges and poles, power, transmission and telecommunication lines, warehouses of containing oil products and other fuel. It causes injury to people and animals.

Students' activity

Mock Drill: To escape a fire, **stop, drop, and roll.** In case your clothes burn, stop running, drop on the floor and roll to stop fire spreading.

During droughts or windy weather, fire may destroy low vegetation and trees. The spreading speed of low fire is 1-3 m/sec and high fire may reach up to 100m/sec.

Think why?

Smoke kills more than fire.

Rule of actions for Fire Accident-Do's

1. When Fire accident occurs, warning should be given by shouting or ringing bell.
2. Extinguish the fire using sand and other fire extinguishers.
3. Main switch should be switched off immediately.
4. If clothes started burning, the victim should roll on the ground to extinguish the fire.
5. The combustible materials found near the fire accident place, have to be discarded so that the fire does not spread to them.
6. If fire breaks out with smoke spreading, cover the nose, crawl and move out.
7. Think that life is more valuable than belongings.
8. Move from the fire accident place to a safe place.

**Preventive Measures**

1. Create a safe zone between the house and flammable plants.
2. Cut off all the branches of trees with below three meter height standing near your house.
3. Remove moss and dry branches from plants standing near the house.
5. Clean ditches and pits from dry branches and leaves.
6. Keep flammable materials in the checked safe containers.
7. Ask your relative or friend living in a different location to be your contact person.
8. Have a fire extinguisher and know how to use it.



A natural gas vent in Iraq known as The Eternal Fire of Baba Gurgur, meaning 'Father of Fire' has been burning continuously for over 4,000 years, and it has been mentioned by Herodotus, and Plutarch.

During fire accident

1. When water cannot be used (because the equipment is plugged-in) or there is no water and the fire is not strong, you can use cooking soda or calcite soda, washing powder, sand, soil.
2. Keep your head no higher than 30 cm above the floor; above this height accumulation of heavy harmful gases may exists.
3. If there is no opportunity to leave the room, move towards a window, and try to get the attention of people by giving signals.
4. If your clothing has caught fire do not run because this will intensify burning. Take the clothes off, throw them in a safe place and put out the fire.
5. If you are near a fire in a forest and cannot extinguish the fire by yourself, immediately inform people who are nearby about the necessity to leave the hazard zone.

Tips to use fire extinguisher:

Put out small fire with fire extinguisher or cover the source of fuel with blanket. For fire extinguisher remember to use pull safety pin from handle. Aim at the base of the flame. Squeeze the trigger handle. And sweep from side to side at the base of the flame.

Things that must never be done during a fire

1. Never pour water on burning electrical equipment if it is switched on. If a TV set, a refrigerator is burning, turn off the electricity from the main switch.
2. Do not jump from windows of upper floors.
3. Do not panic.
4. Do not try to extinguish the fire by yourself.

8.3.4 Industrial Disasters

Industrial hazards consist of four principle hazards. The hazards encountered are fire, explosion, toxic release and environmental damage. This is because industries engage in different processes involving a wide range of different raw materials, waste products and final products. Danger originates from technological or industrial accidents, dangerous procedures, infrastructure failures or certain human activities. It may cause the loss of life or injury, property damage, social and economic disruption or environmental degradation.

Fire: This is the most frequent hazard. Fire can also produce toxic fumes like Acrolein, Carbon monoxide and Cyanides. Physical structures can be damaged either by the intensity of the heat or combustion. It may also have an effect on essential services like power and instrumentation.

Explosion: Explosions is the result of a shock wave. This overpressure can kill people but usually the indirect effects of collapsing buildings, breaking of glasses and falling of debris causes far more loss of life and severe injuries. There are different types of explosions which include gas explosions and dust explosions. Gas explosions occur when a flammable gas mixes with air. Dust explosions occur when flammable solids, especially metals, in the form of fine powders are intensively mixed with air and ignited.

Chemical release: Sudden release of toxic vapours has the potential to cause death and severe injuries several kilometres from the release point. They are carried by water and air. Their release into public sewage systems, rivers, canals and other water courses, either directly or through contaminated water used in fire fighting can result in serious threat to public. The number of casualties depends on the weather conditions, population density in the path of the cloud and the effectiveness of the emergency arrangements.

Environmental Damage: Release of other substances, not directly toxic to humans can cause major pollution problems. It is becoming increasingly recognized that damage to natural resources such as plant and animal life can have serious long term consequences. E.g. destruction of trees is increasing the effect of global warming and extinction of animals are severely disrupting food webs and causing an increase in pests.

Means of reducing the industrial hazards

Process of Safety Management: Reliability assessment of process equipment, incorporating safety tips, scrubbing system, etc, should be done before effecting major process changes.

Safety Audits: Periodical assessment of safety procedures, performance of safety systems and gadgets along with follow up measures should be carried out.

Emergency Planning: A comprehensive risk analysis indicating the impact of consequences and practiced emergency procedures should be done. This can be done by communities as well as national or regional corporation authorities.

Training: Proper training of employees and protective services should be done.

Fact File

The 1984 Bhopal Gas Disaster

The human cost (estimates)

Up to 10,000 deaths in first three days.

Additional 25,000 people died of related injuries by 1994.

8.3.5 Road accident

It is estimated that 1.34 million people are killed in the road accidents every year. Road accident is the 8th leading cause of death globally. Every year, up to 50 million people suffer serious, life-altering injuries which, in many low- and middle-income countries.

Primary road safety risk factors in low and middle-income countries include:

1. Speeding
2. Drink-driving
3. Non-use, or improper use of helmets, and
4. Non-use, or improper use of seatbelts

Strengthening the capability of the road traffic police to enforce traffic laws is fundamental to deterring road users from violating the laws, to reduce harm and to reduce inappropriate and unsafe behaviors on the roads.

Basic road safety rules for students:

1. Aware of the road signals

Assist students to learn the traffic lights and signs. Check out the relevance of each color:

- Green light is an indication for “go”- Whenever the signal turns green, the vehicle can move ahead.
- Red light is an indication “to stop”- All the vehicles have to stop, when the red light is on.
- Yellow light is an indication “to slow down”- When the yellow light turns on, you should slow down your vehicle and prepare to stop.
- “Walking man” signal at intersections are constructed for the pedestrians. Recall the fact that you will be authorized to cross the road only when the signal turns green.

Ensure that there are no vehicles, both on the left and right side of the road.

- ▶ Never attempt to cross the road, if the signboard signifies “Don’t walk” message or the walking symbol turns red.

2. Stop, look, and cross

In fact, students will either walk to school or to the bus stop for waiting their respective school bus. The only task of students is to cross the road prudently, right after the school bus drops them off. Hence, we should undertake the responsibility to provide adequate guidance for crossing the road cautiously.

We teach them to be aware of various road signs and recommend them to utilize the zebra crossing while crossing the road. If there are no markings or signs, the following procedures can be worthwhile:

- ▶ Check the right side, after that to the left side of the road for the incoming vehicles.
- ▶ If you notice a vehicle is approaching, wait for the vehicle to pass and then safely cross the road.
- ▶ Do not cross the road at the turns, it is unsafe.
- ▶ Never cross the road between the stopped vehicles.

However, accompaniment is required for the children aged below 6 years and you should compulsorily hold their hands while crossing the road.

3. Listen

Educate the child to be extra vigilant while they cross the road at the turns. As a consequence, listening can only aid them. For this reason, instruct your child to listen and ensure whether a vehicle is approaching or not. Ordinarily, vehicles apply horns at turns and at unmanned intersections to provide a warning to other road users. Meanwhile,

you can interpret the following instances to students:

- ▶ If a horn is heard, stop and cross only after ensuring that no vehicle approaches you from left or right side of the road.

4. Don’t rush on roads

Students will not be tolerant and have a tendency to dash across the road to reach the other side. In addition, they become absent-minded when they are having fun and henceforth bound across or along the road. Therefore, teach them to remain placid while they are near the road.

5. Relevance of Sidewalks

Persuade students to avail the service of sidewalks whenever they walk on the road. Demonstrate them how to cross the road safely. Motivate them to avail the sidewalks even though it is not a busy street.

6. Crossroads and pedestrian crossings

Students will have a tendency to scoot across the street. This will become particularly perilous since vehicles will never slow down unless there is a cross road or relevant signal. Notify your students to cross only at intersections and avail the pedestrian crossings. If there is no crossroad or pedestrian crossing, you can admonish students to comply the rules mentioned above.

7. Place the hands inside the vehicle

A multitude of students have the habit of placing their hands outside the vehicle while it is moving. They will lay their head out and wave with exhilaration. This is a familiar sight among the school bus students. Nevertheless, these behaviors can have significant consequences. Due to carelessness, they will be injured by vehicles, which advance from the opposite direction.

Back to School.

MOTORIST TIPS FOR CHILDREN'S SAFETY

What Can I Do?

Do Not Pass

It is illegal to pass a school bus that is stopped to load or unload children.



Seeing Yellow

School buses use yellow flashing lights to alert motorists that they are preparing to stop to load or unload children.



Seeing Red

Red flashing lights and an extended stop sign arm signals to motorists that the bus is stopped and children are getting on or off the bus.

All Stop

Traffic in both directions stop on undivided roadways when students are entering or exiting a school bus.



Stay Behind

Traffic behind a school bus (traveling in the same direction) must stop.



Crosswalks

Do not block the crosswalk.

Distance

Stop your car far enough from the bus to allow children the necessary space to safely enter and exit the bus.



Never Pass on Right

Never pass a school bus on the right.



Look Out

Take extra care to look out for children in school zones, residential areas, playgrounds and parks.

Stop

Always stop when directed to do so by a school patrol sign, school patrol officer or designated crossing guard



Stay Alert

Children are the least predictable pedestrians and the most difficult to see.



Don't Honk

Don't honk your horn, rev your engine or do anything to rush or scare a child in front of your car.



8. Never cross road at bends

Bends are evidently the blind spot for motorists. When you attempt to cross at bends, the driver will be unable to recognize you and stop the car at the right time. As a result, students will be hurt while crossing at bends.

9. Remain safe on a bicycle

If students ride bicycle to reach the school, ensure that they adhere to the following cycling rules:

- Utilize the bicycle lane. If such a lane does not exist, ride the bike either on the extreme left or right side of the road and glide along with the traffic.
- Never permit your students to ride on congested streets without your supervision.

10. Staying safe in a moving vehicle

In a moving vehicle, you can ensure the student's safety with the assistance of a seat belt. Let them practice the following safety rules in your absence:







- Never stand, stroll or sprint inside a moving vehicle.
- Remain seated and hold the rails on the seats until the school bus halts.
- Do not put your hands outside the moving vehicle.

11. Get off the vehicle at the curb side

Ask your students to memorize the following safety tips and conform to the rules while they get down from the school bus:

- Ensure that you reach the bus stop prior to the scheduled bus timing in order to avert the circumstance of running behind the school bus.
- Form a queue to board or descend the school bus.
- Disembark the school bus at the curbside in order to evade unnecessary endangerment and hindrance to other vehicles.

Top 10 Road Safety Tips for Children

- | | | | |
|---|--|--|---|
| <p>1 Crossing the road
On a green light, look both ways and listen for traffic before crossing</p> |  | <p>6 Getting off a bus
Watch out for cars or motorcycles when getting off</p> |  |
| <p>2 Around the corner
Do not run into the roadway</p> |  | <p>7 Crossing the road without signal lights
Pay additional attention before crossing</p> |  |
| <p>3 Do NOT jaywalk
Make sure to use a crosswalk</p> |  | <p>8 Wear a seat-belt
Children under 13 are safest in the back seat</p> |  |
| <p>4 Watch out for big cars
Stay away from big cars turning the corner</p> |  | <p>9 Do NOT play between cars
stationed side by side</p> |  |
| <p>5 Do NOT play behind cars
Drivers may not be able to see you</p> |  | <p>10 Use safety gear on bicycles and in-line skates
Use bicycle lanes when available</p> |  |

A-Z GLOSSARY

1. **Disaster:** A serious disruption of the functioning of a society involving human, and material, and impacts that exceed the ability of the affected society to cope using its own resources.
2. **Disaster risk reduction:** The practice of reducing disaster risks through systematic efforts to analyze and manage the causal factors of disasters.
3. **Mitigation :** The lessening of the adverse impacts of hazards and related disasters
4. **Preparedness:** The capacity developed by organizations, to effectively anticipate, respond to, and recovers from the impacts of disaster events.
5. **Prevention:** The outright avoidance of adverse impacts of hazards and related disasters.
6. **Public awareness:** The extent of common knowledge about disaster risks, the factors that lead to disasters and the actions that can be taken, to reduce vulnerability to hazards.
7. **Resilience:** The ability of a society exposed to hazards to resist, absorb, adapt to and recover from the effects of a disaster.
8. **Hyogo Framework for Action** – a global blueprint for disaster risk reduction efforts between 2005 and 2015 – by providing specific operational guidance for promoting disaster risk reduction.

Exercise

I. Choose the Correct Answer



- The spreading speed of low fire is
 - 1 – 3 m/sec
 - 3 – 5 m/sec
 - 4 – 6 m/sec
 - 6 – 8 m/sec
- It is important to practice Drop, Cover, Hold for
 - Fire
 - Earthquake
 - Lightning
 - Flood
- To cut off all branches of trees standing near our house is to prevent
 - Earthquake
 - Flood
 - Fire
 - Drought
- Which one of the following is the rule of action for stampede?
 - Find lower place or cavity and squat there if the area is open.
 - Avoid rock slides and landslides if you are in the mountain.
 - Keep your hands by your chest
 - Keep your head no higher than 30 cm above the floor.
- The 1984 Industrial gas disaster occurred in
 - Delhi
 - Pune
 - Bhopal
 - Noida
- The percentage of death worldwide due to unintentional injury during drowning is _____.
 - 5%
 - 7%
 - 10%
 - 2%
- The natural gas vent known as the Eternal fire of Baba Gurgur is located at which country?
 - Iran
 - Iraq
 - Yeman
 - Kuwait
- Every year, _____ people are killed in the road accidents.
 - 4.34 million
 - 2.34 million
 - 3.24 million
 - 1.34 million
- In India _____ of stampede occur in religious events.
 - 69%
 - 59%
 - 79%
 - 49%
- Drowning account for _____ of deaths in flood disasters.
 - 75%
 - 65%
 - 55%
 - 85%

II Very short answer

11. Why should not we cross roads at bends?
12. What are the causes of fire accident?
13. List major areas of stampede.
14. Write any three preventive measures of fire accident.
15. Write any two road safety risk factors.

III Write the short answer

16. Why are we drowning faster in fresh water than ocean water?
17. Write any three do's during fire accident.
18. Mention any two means of reducing industrial hazards.
19. Write any three preventive measures of drowning.

IV Write in detail

20. List the basic road safety rules for students and explain any three of them.
21. Write any three do's and don'ts for fire accidents.
22. Explain the rules of action during Stampede.

V Mock drill exercise

1. Prepare a school disaster management plan focusing on the following mock drills that can be scheduled to be conducted by the various committees.
 - I. Drop, cover, roll mock drill for fire
 - II. Stampede

VI Group discussion

1. Discuss in group how you can manage stampede suppose you are trapped in the crowd in a festival site/ Mall. Draw easy exit route map of the site and discuss about.



References

1. Introduction to Disasters (reference – unisdr.org, 2006 edition)
2. Disaster Mangement module. TNSCERT.
3. Farabi, Hamid. "Safety: A major objective in the Chemical and Petroleum Industry." 1992.
4. Mannan, Sam. Lee's Loss Prevention. Oxford: Elsevier Butterworth Heinemann, 2005.



ICT CORNER

MAN MADE DISASTER (FIRE)

This activity enables the students to understand about the nature of the man made and disaster and how we can handle the situation.



Steps

- Type the URL link given below in the browser or scan the QR code. A page opens with “Play” symbol.
- When we touch it, It opens into another page with instructions. When we finish that it opens into another page. Contains many fire fighting vehicles.
- Select the vehicle of your choice then do every thing according to the given instructions.
- At last when we finish everything ie quench the fire we will be satisfied for our task.

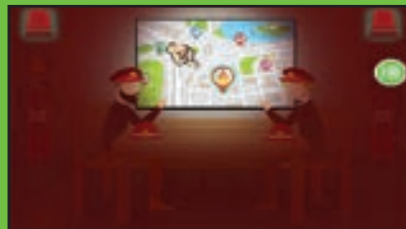

Step 1



Step 2



Step 3



Step 4

Website URL:

<https://play.google.com/store/apps/details?id=com.frosstudio.mytownfirerescue>

*Pictures are indicative only.



UNIT 9

Surveying

Unit Overview

- 9.1 Introduction
- 9.2 Clinometers
- 9.3 Prismatic Compass

9.1 Introduction

Surveying has been an essential element in the development of man's environment for centuries. It is important in planning and execution of every form of construction. Surveying is used to map the earth above and below the sea, prepare navigational maps and establish databases for natural resource management, development of engineering data for huge buildings, constructions, settlements, roads, railways, bridge constructions and so forth.

Surveying is the science of measuring and recording distances, angles, heights and sizes of the earth's surface to obtain data from which accurate plans and maps are made. Generally, surveying is the systematic process of making measurements on the field from which maps are drawn. The map is the most essential piece of equipment which the geographer, engineer and architect use. The geographers must learn to read, make and use maps as an essential element. In this lesson, we will see about clinometers and Prismatic Compass.



Learning Objectives

- Understand the importance of surveying in general.
- Measuring the height of an object using clinometers.
- Conduct and calculate the prismatic compass survey of a given spot.



9.2 Clinometers

In this Instruction, we will learn how to use clinometers to measure the height of a tall object. What you will need; Clinometers, Tape, Paper, Pen or pencil, Assistant.

Step 1: Pick a Spot

Let us pick a spot to measure your object which may be a tree or electric or telephone pole. You should be far enough away from your object that you can see the top of it, and you need to be on level ground with the base of the object.

Step 2: Measure Angle

Here's where we bust out our handy clinometers. Look through the straw of your clinometers at the top of the tree or whatever object you're measuring. The weighted

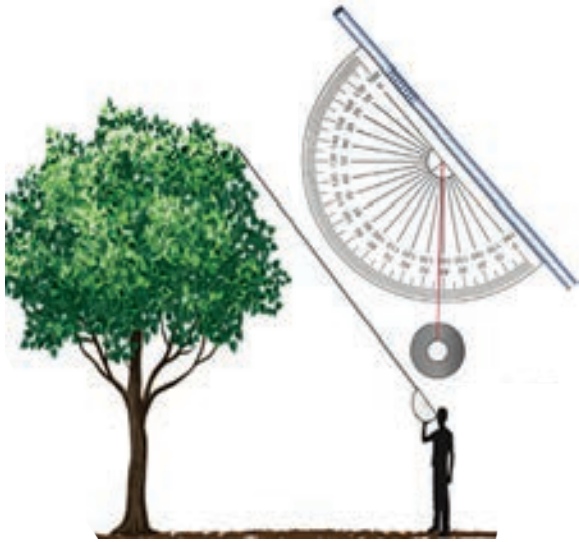

string should hang down freely, crossing the protractor portion of the clinometers. Read the angle shown, and subtract from 90° to find your angle of vision from your eye to the top of the tree (it can be helpful here to have an assistant to read the measurement while we look through the straw). We record our results on a paper. From the spot, the clinometers (read by assistant) show 55° . Subtracting from 90° that indicated that we looked at an angle of 35° to the top of the tree.

Step 3: Measure Distance

Once we have our angle of vision, we can use tape measure to find the distance from the spot we are standing to the base of the object we are measuring (an assistant comes in handy here, too). We must know how far away we are to accurately calculate the height. Our spot was 15.6 meters from the base of the tree we measured.

Step 4: Find Your Eye-height

The last piece of data you need to calculate the height of the object is the height from the ground to our eye (our eye-height). We must have the assistant help us measure this using our tape measure. Our eye height was recorded for this example as 1.64 metres.

Step 5: Draw a Picture

In calculating the height of the object you just measured, we find it helpful to begin by

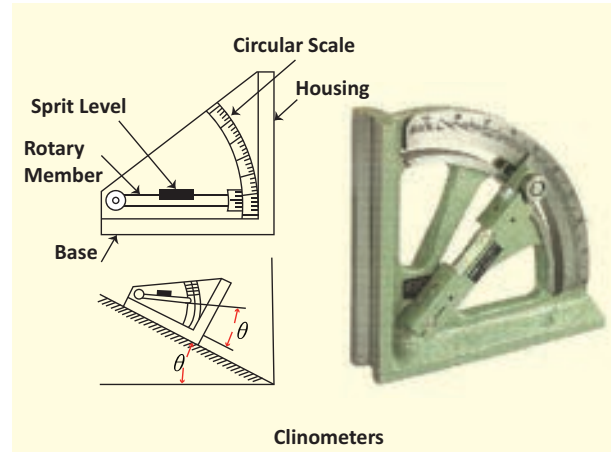

drawing a picture and labeling it with all of the information we have.

Step 6: Model as a Triangle

The next step is to simplify our drawing to model our system as a right triangle. Label our triangle with the angle we read on our clinometers as well as the distance you were standing from the object (we don't need the eye-height just yet).

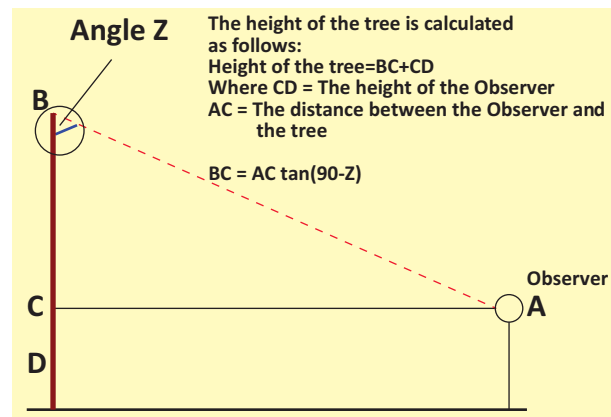

We can find x in this triangle (which represents the portion of the height from eye-level up) by using some basic trigonometry, specifically the tangent ratio of the triangle:

$$\tan(\text{angle}) = x / \text{distance}$$

Multiply by the distance on both sides and you get:

$$x = \tan(\text{angle}) * \text{distance}$$

Use a calculator to multiply these together and get a decimal value.

In the example:

$$\tan(35^\circ) = x / 15.6$$

$$x = \tan(35^\circ) * 15.6$$

$$x = 10.92 \text{ metres}$$

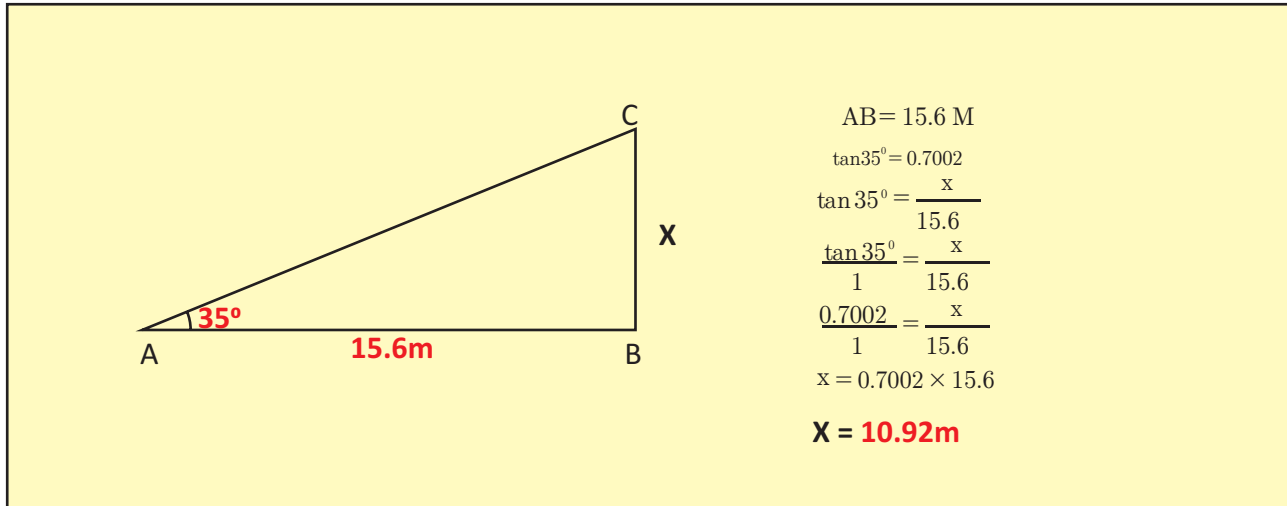

Step 7: Combine with Eye Height

To find the height of our object, we bring this x value back to the original drawing. By labeling it, we can see that the height of the object, h, is equal to the x value we just found plus the eye-height we measured earlier:

$$h = x + (\text{eye-height})$$

In the example:

$$h = 10.92\text{m} + 1.64\text{m}$$

$$h = 12.56\text{m}$$

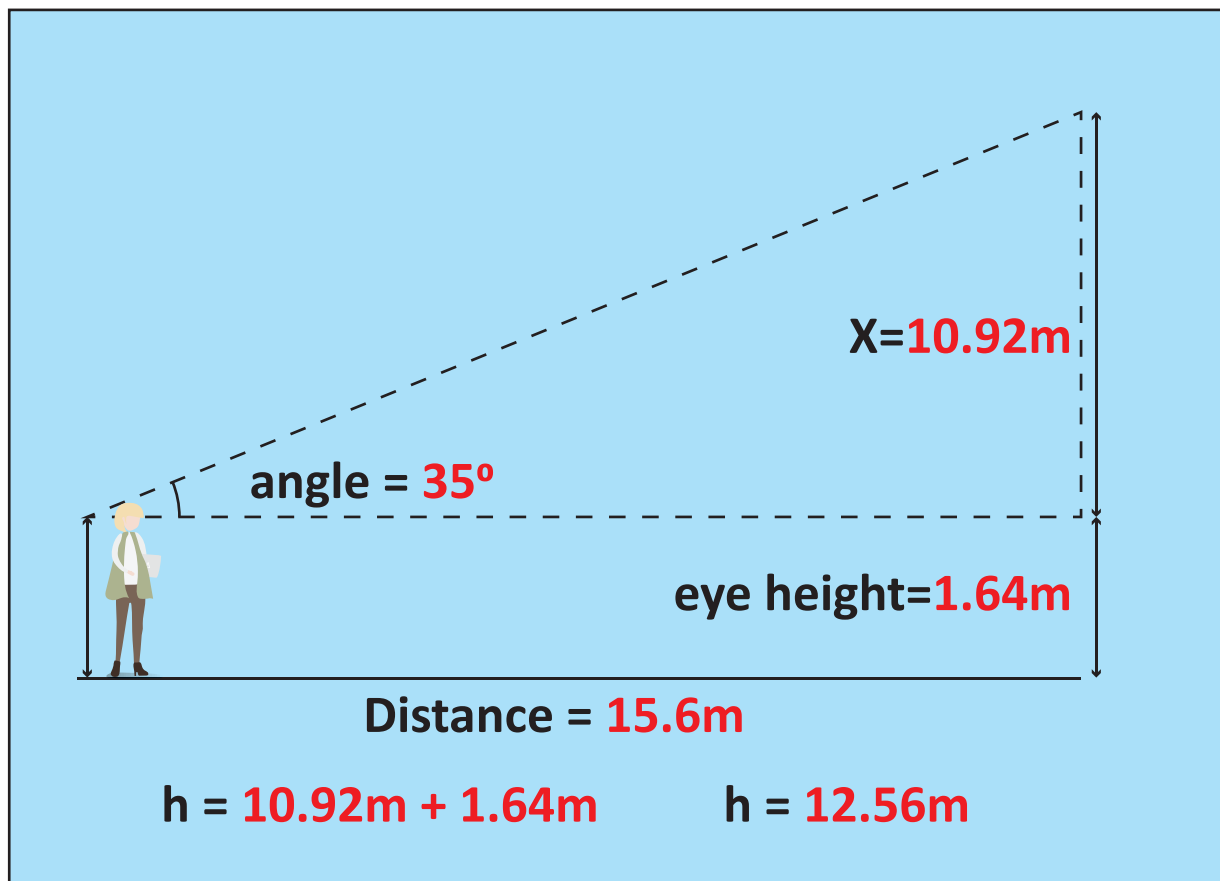

Exercise

Find out the height of the building shown below. Or Find out the height of a tree or building or electric pole near your premise. Given eye sight and distance from the building are 1.5m and 18m respectively

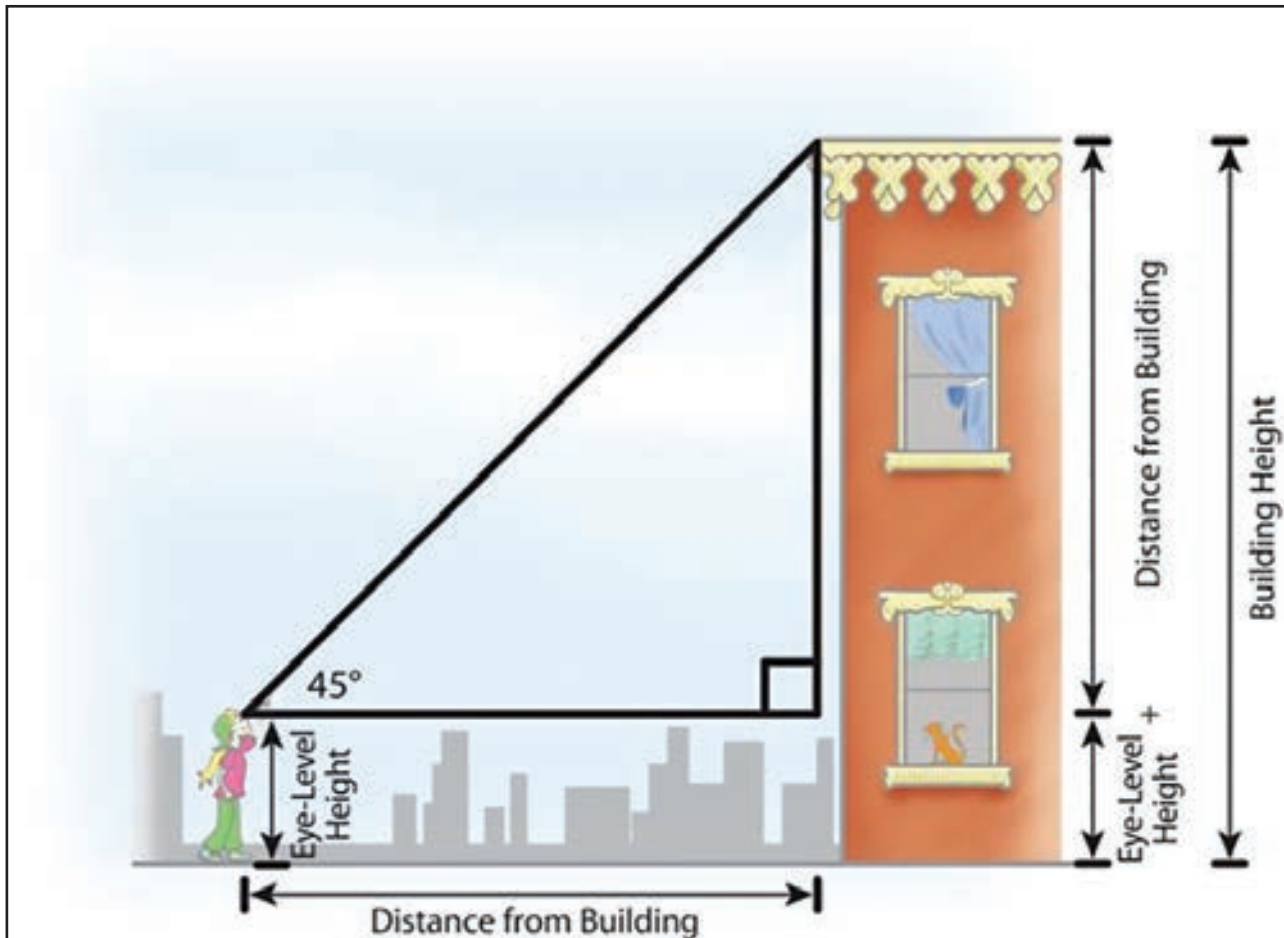

9.3 Prismatic Compass

Prismatic compass is a simple instrument comprising an aluminum ring graduated to 30 minutes held at the top of a broad magnetic needle set in balance on a hard steel pivot. This compass is fitted in a circular metal box with a transparent glass cover. The glass – top is further covered with a hinged metal lid. On one side of the circular box there is a hinged eye- vane with a prism having convex vertical and horizontal face in order to magnify the marking of degree on the aluminium ring as reflected from the hypotensual side of the prism. Two coloured sunglasses are set at a hinge to avoid direct sun rays at the eye vane.

On the other side of the circular box, there is a sighting vane consisting of a hinged metal frame with a horse hair at the centre. This horse hair in reality may be a fine silk thread or a metal wire. A hinged adjustable mirror is set on the outer side of the sighting vane in order to locate the too high or too low object through reflection.

There is a brake pin or knob which brings the oscillating circular ring to standstill.

The metal box has a threaded bottom which can be screwed in by another threaded knob at the top of a ball fitted and adjustable in a socket of the compass- stand.

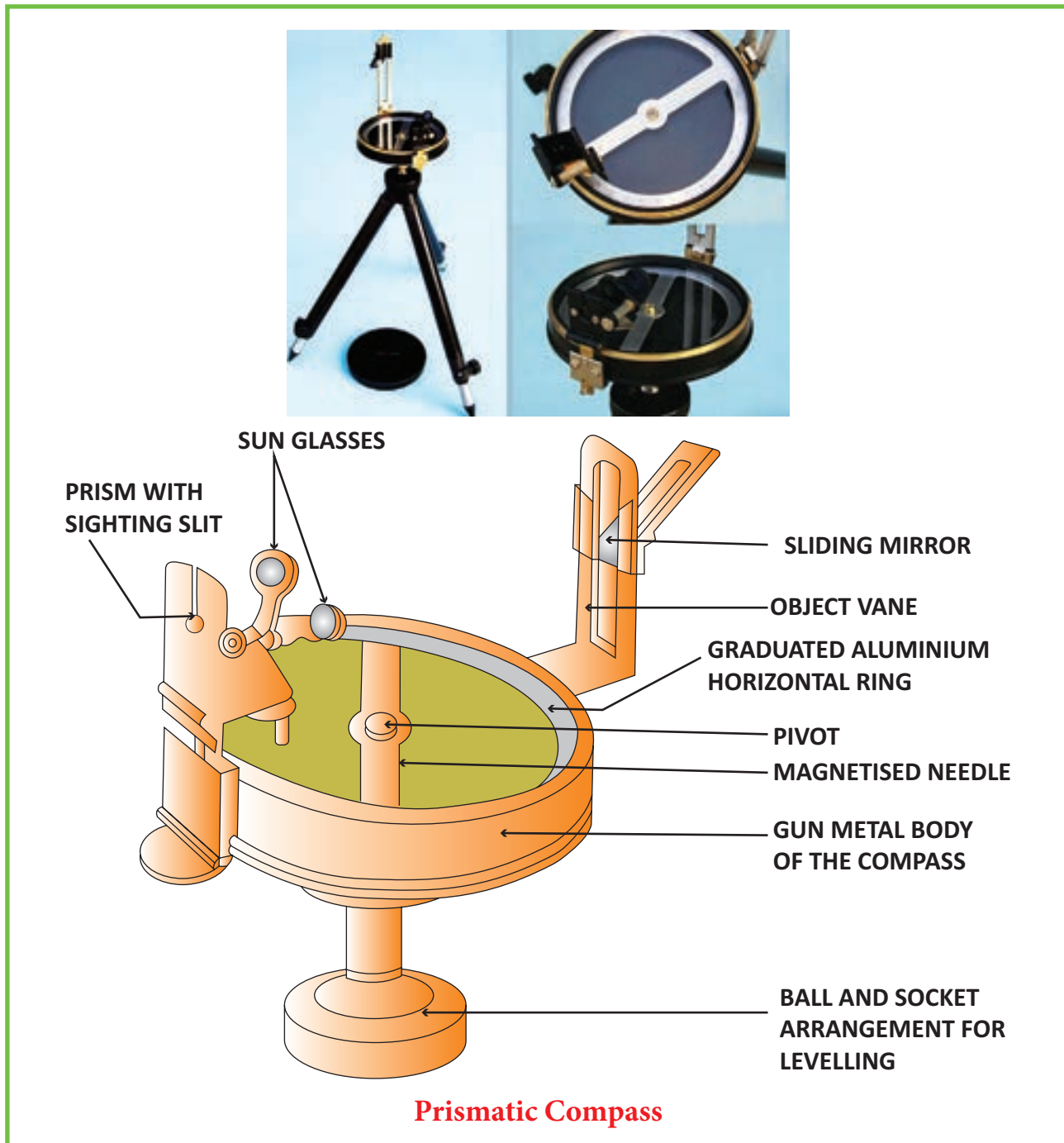

Use of Prismatic Compass

Prismatic compass measures the horizontal angle with reference to the magnetic north-line. The bearing thus obtained is a magnetic bearing which is measured as a horizontal angular distance of any line of the traverse from magnetic north in clock wise direction.

The corners of plot or building, bends of a road can be measured directly by prismatic compass. The bends of a meandering canal, if divided into segments, can be favourably determined by a prismatic compass.

Exercise

Observe the prismatic compass. Note the name and function of each and every part.

UNIT 10

Map Projection

Unit Overview

- 10.1 Introduction
- 10.2 Classification of Map Projections
- 10.3 Construction of Some selected Map Projections

10.1 Introduction

A Map projection means the representation of latitude and longitude of the globe on a flat sheet of paper. The network thus formed is called graticule. Map projection is a mathematical expression using the three-dimensional surface of earth is represented in a two dimensional plane. The process of projection results in distortion of one or more map properties such as shape, size, area or direction.

10.2 Classification of Map Projections

Map projections are classified on the following criteria:

- Method of construction
- Development surface used
- Projection properties
- Position of light source



Learning Objectives

- To Understand the concepts of map projection
- To Understand the classification and properties of map projection
- To develop graphical construction of cylindrical and polar zenithal projection
- To interpret a various aspects of map projection



Classification based on Methods of Construction

Given below are the projections that are based on the method of construction:

a). Perspective Projections: These projections are made with the help of shadow cast from an illuminated globe on to a developable surface.

b). Non Perspective Projections: A developable surface is only assumed to be covering the globe and the construction of projections is done using mathematical calculations.

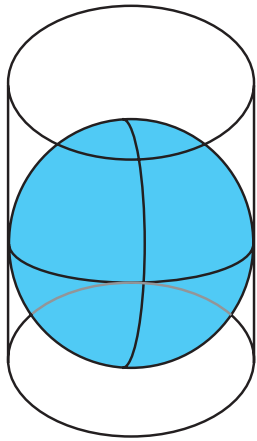

Cylindrical Projection

Classification based on Developable Surface used

The three basic projections are based on the types of developable surface. They are:

1 Cylindrical Projection

- It can be visualized as a cylinder wrapped around the globe.
- The longitudes (meridians) and latitudes (parallels) appear as straight lines.
- Length of equator on the cylinder is equal to the length of the equator, therefore, it is suitable for showing equatorial regions.

Normal: when a cylinder has line of tangency to the equator. It includes Equirectangular Projection, the Mercator projection, Lambert's Cylindrical Equal Area, Gall's Stereographic Cylindrical, and Miller cylindrical projection.

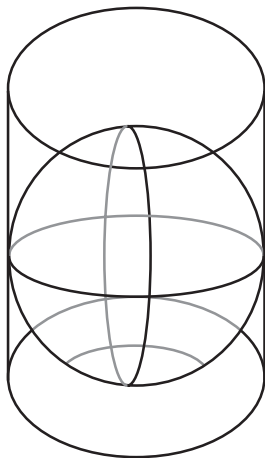

(a) Normal

Transverse: when cylinder has line of tangency to the meridian. It includes the Cassini Projection, Transverse Mercator, Transverse cylindrical Equal Area Projection, and Modified Transverse Mercator.

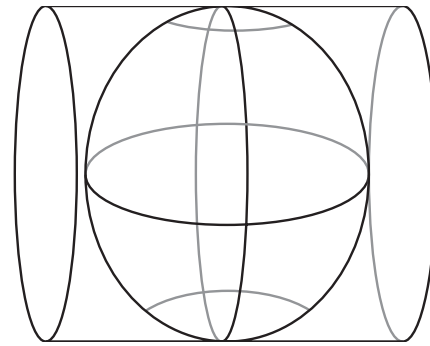

b) Transverse

Oblique: when cylinder has line of tangency to another point on the globe. It only consists of the Oblique Mercator projection.

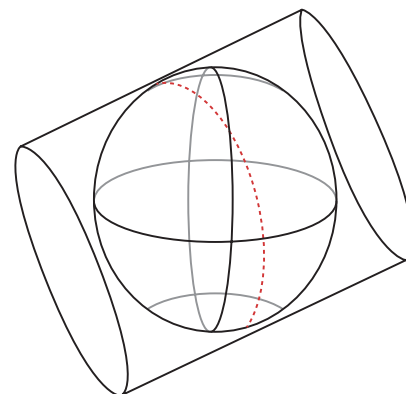

(c) Oblique

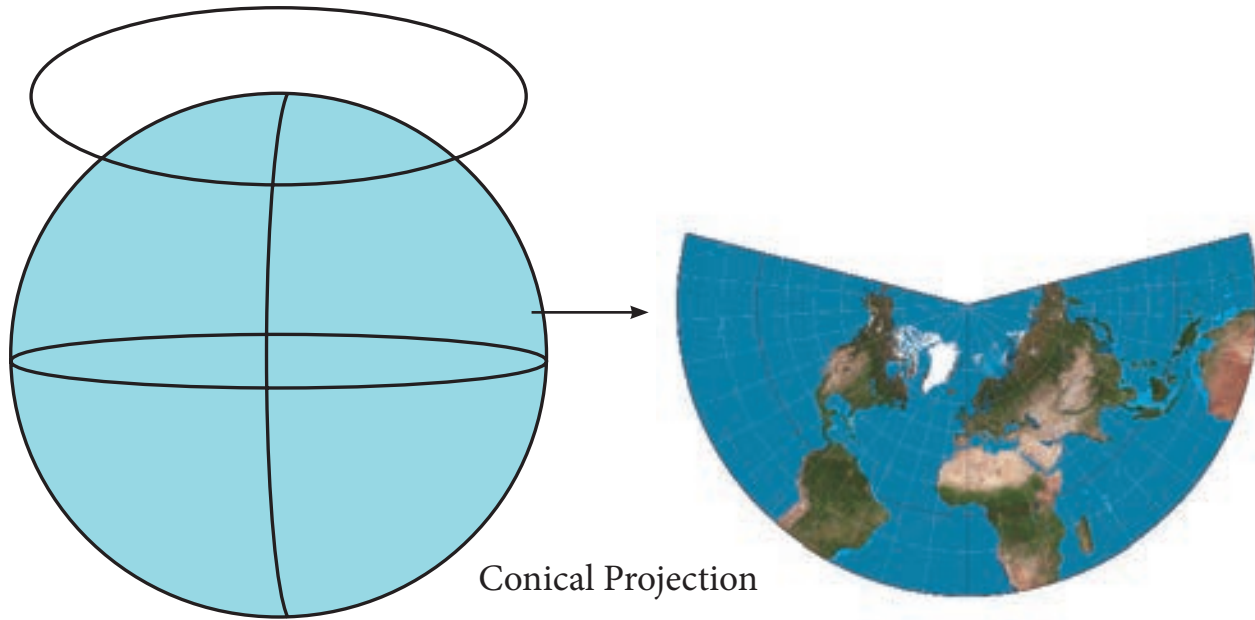

2. Conical Projection

- It can be visualized as a cone placed on the globe, tangent to it at some parallel.
- After projecting the graticule on to the cone, the cone is cut along one of the meridian and unfolded. Parallels appear as arcs with a pole and meridians as straight lines that converge to the same point.
- It can represent only one hemisphere, at a time, northern or southern hemisphere.
- It is suitable for representing middle latitudes.

Conical projection is divided into two. They are

Tangent: when the cone is tangent to only one of the parallel.

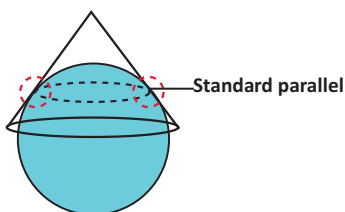

Secant: when the cone is not big enough to cover the curvature of earth, it intersects the earth twice at two parallels.

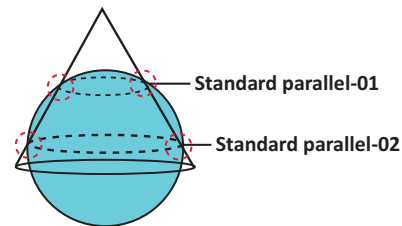

3. Azimuthal /Zenithal Projection

- It can be visualized as a flat sheet of paper tangent to any point on the globe
- The sheet will have the tangent point as the centre of the circular map, where meridians passing through the centre are straight line and the parallels are seen as concentric circle.
- Suitable for showing polar areas

Aspects of zenithal projection:

Equatorial zenithal: When the plane is tangent to a point on the equator.

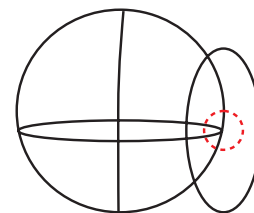

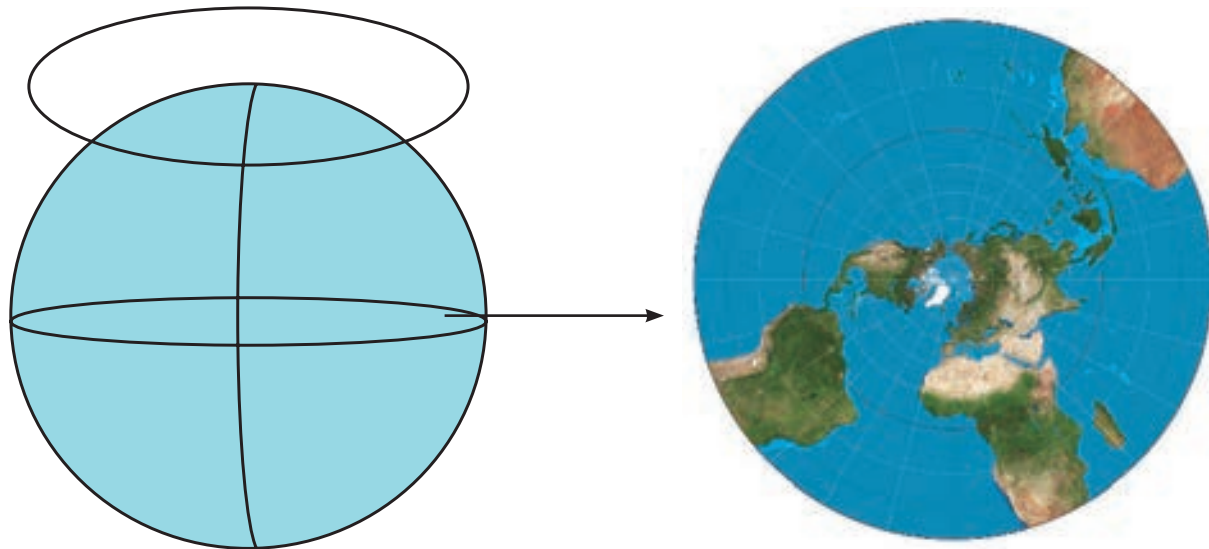

Zenithal Projections

Oblique zenithal: when the plane is tangent to a point between a pole and the equator.

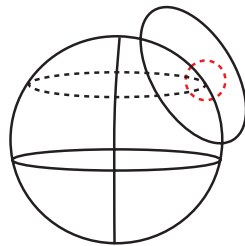

Polar zenithal: when the plane is tangent to one of the poles.

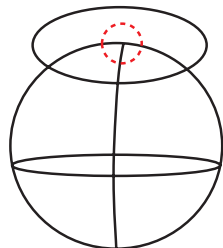

of different parts of earth are correctly represented on these projections.

True scale or equidistant projections: Projections that maintain correct scale are called true scale projections. However, no projection can maintain the correct scale throughout. Correct scale can only be maintained along some parallels or meridians.

Classification based on Position of light source

Placing light source illuminating the globe at different positions results in the development of different projections. These projections are

Gnomonic projection: when the source of light is placed at the centre of the globe

Stereographic Projection: when the source of light is placed at the periphery of the globe, diametrically opposite to the point at which developable surface touches the globe.

Orthographic Projection: when the source of light is placed at infinity from the globe opposite to the point at which developable surface touches the globe.

According to properties, map projections can be classified as:

Equal area projection: It is also known as homolographic projections. The areas of different parts of earth are correctly represented by such projections.

True shape projection: It is also known as orthomorphic projections. The shapes



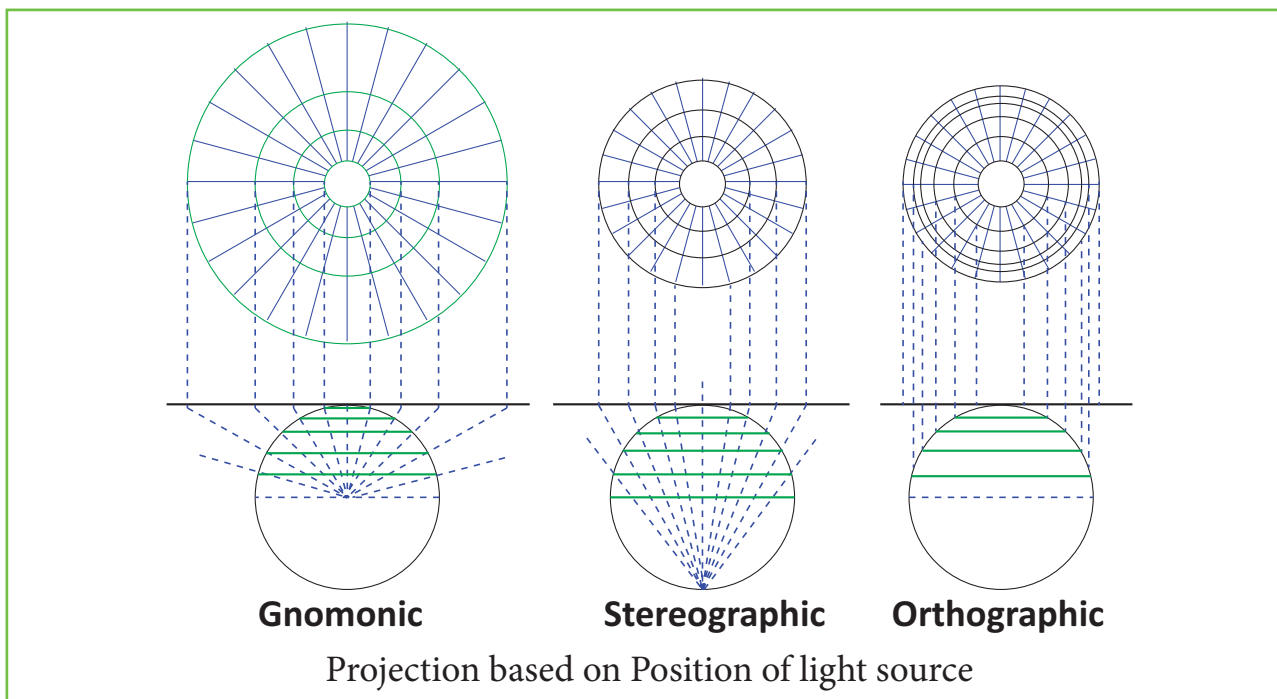

10.3 Construction of Some selected Map Projections

Cylindrical Equal Area Projection / Lambert's Cylindrical Equal-area projection

It is devised by JH Lambert in 1772. It is a normal perspective projection onto a cylinder tangent at the equator.



Properties of Cylindrical Equal Area Projection

- Parallels and meridians are straight lines.
- The meridians intersect parallels at right angles.
- The distance between parallels decreases toward the poles but meridians are equally spaced.
- The length of the equator on this projection is same as that on globe but other parallels are longer than corresponding parallels on globe. So, the scale is true along the equator but is exaggerated along other parallels.

Example 10.1

Construct a cylindrical equal area projection for the whole globe with a reduced earth radius of 2 cm and the latitudinal and longitudinal interval 30° .

Construction:

- Draw a circle of 2 cm radius with O as centre.
- Draw the equator (WE) and the Polar N-S axis.
- Mark the angles of 30° , 60° for both the hemispheres. And label it as B, C, B' and C' respectively.
- Extend the line WE to E'
- Divide the line EE' into 12 equal parts ($360/30$) with the distance of EB. This line represents the Equator.
- Through each point draw perpendiculars which represent the longitudes
- Draw parallel lines at N, C, B, B', C' and S equal to EE' to represent 30° , 60° and 90° latitudes for both the hemispheres. Complete the projection as shown in Figure.

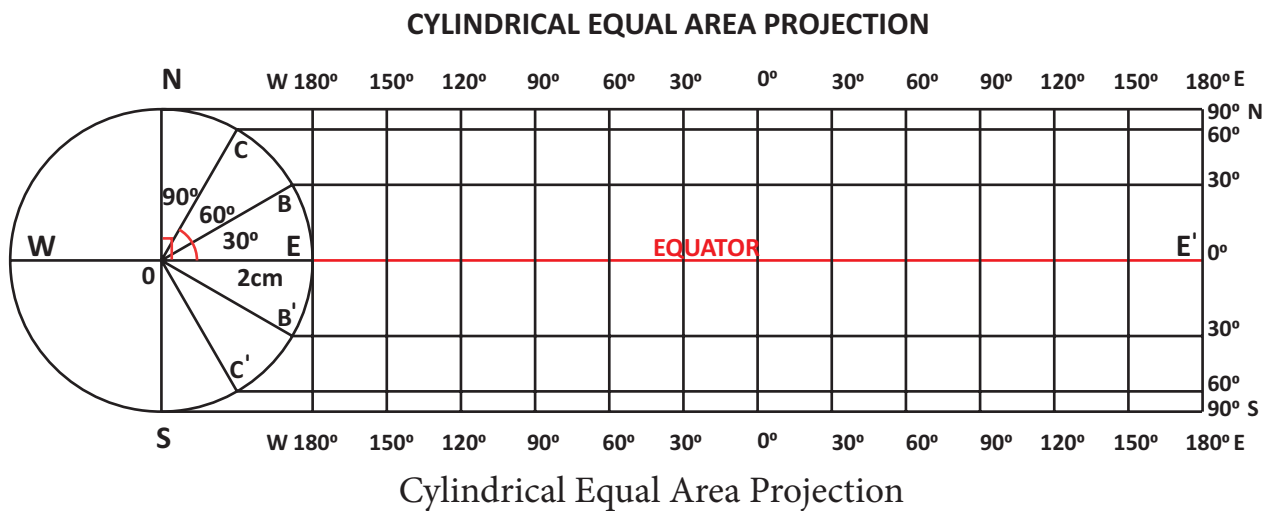



Cylindrical Equi –Distant Projection

This is a Projection on to a cylinder which is tangent to the equator. It is believed to be invented by Marinus of Tyre, about C.E. 100.



Properties of Cylindrical Equi-Distant Projection

- Poles are straight lines equal in length to the equator.
- Meridians are straight parallel lines, equally spaced and are half as long as the equator. All meridians are of same length therefore scale is true along all meridians
- Parallels are straight, equally spaced lines which are perpendicular to the meridians and are equal to the length of the equator.
- Length of the equator on the map is the same as that on the globe but the length of other parallels on map is more than the length of corresponding parallels on the globe. So the scale is true only along the Equator and not along other parallels.
- Distance between the parallels and meridians remain same throughout the map.
- Since the projection is neither equal area nor orthomorphic, maps on this projection are used for general purposes only.

Example 10.2

Construct a cylindrical equi-distant projection for the whole globe with a reduced earth radius of 2 cm and the latitudinal and longitudinal interval 30° .



Construction:

- Draw a circle of 2 cm radius with O as centre.
- Mark the angles of 30° northern hemisphere and label it as C.
- Draw a line AB long to represent the equator.
- Since the meridians are to be drawn at an interval of 30° divide AB into 360/30 i.e 12 equal parts with distance of EC.
- To draw meridians, erect perpendiculars on the points of divisions of AB. Take these perpendiculars equal to the length specified for a meridian and keep half of their length on either side of the equator.
- A meridian on a globe is subtended by 180°. Since the parallels are to be drawn at an interval of 30°, divide the central meridian into 180/30 i.e. 6 parts.
- Through these points of divisions draw lines parallel to the equator. These lines will be parallels of latitude. Complete the projection as shown in Figure.

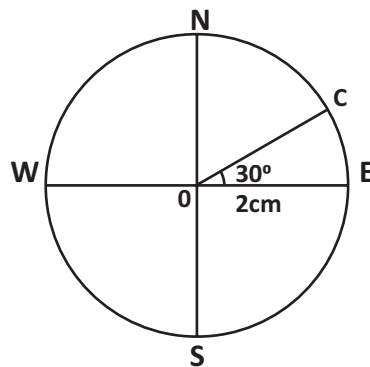

CYLINDRICAL EQUI DISTANT PROJECTION

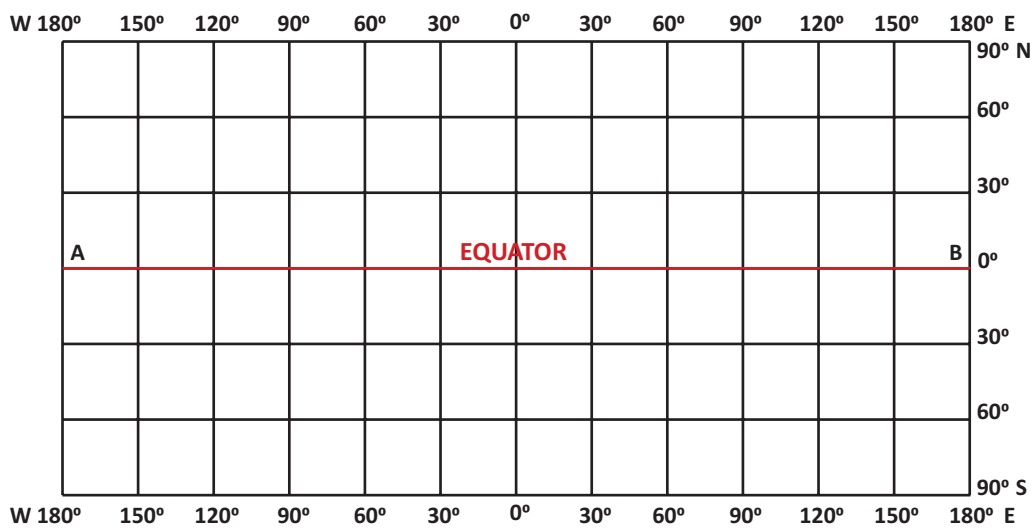

Cylindrical Equi-distant Projection

Polar Zenithal Projection

Polar Zenithal Equal area projection

This projection is invented by J.H Lambert in the year 1772. It is also known as Lambert's Equal Area Projection.



- The pole is a point forming the centre of the projection and the parallels are concentric circles.
- The meridians are straight lines radiating from pole having correct angular distance between them.
- The meridians intersect the parallels at right angles.
- The scale along the parallels increases away from the centre of the projection.
- The decrease in the scale along meridians is in the same proportion in which there is an increase in the scale along the parallels away from the centre of the projection. Thus the projection is an equal area projection.
- Shapes are distorted away from the centre of the projection. Scale along the meridians is small and along the parallels is large so the shapes are compressed along the meridians but stretched along the parallels.
- Used for preparing political and distribution maps of Polar Regions. It can also be used for preparing general purpose maps of large areas in Northern Hemisphere.

Example 10.3

Construct a Polar zenithal equal area projection for the whole globe with a reduced earth radius of 4 cm and the latitudinal and longitudinal interval 30°

Steps of construction:

- Draw a circle with radius equal to 4 cm representing a globe. Let CD and AB be the polar and equatorial diameters respectively which intersect each other at right angles at O, the centre of the circle.
- Draw radii OE, OF, OC, making angles of 30° , 60° and 90° respectively with OB. Join CB, CE, and CF by straight lines.
- With radius equal to CF as centre draw a circle. The point represent 90° parallel and



mark it as N. This circle represents 60° parallel. Similarly with centre N and radii equal to CE and CB draw circles to represent the parallels of 30° and 0° respectively.

- Using protractor, draw other radii at 30° interval to represent other meridians.
- Complete the projection as shown in Figure.

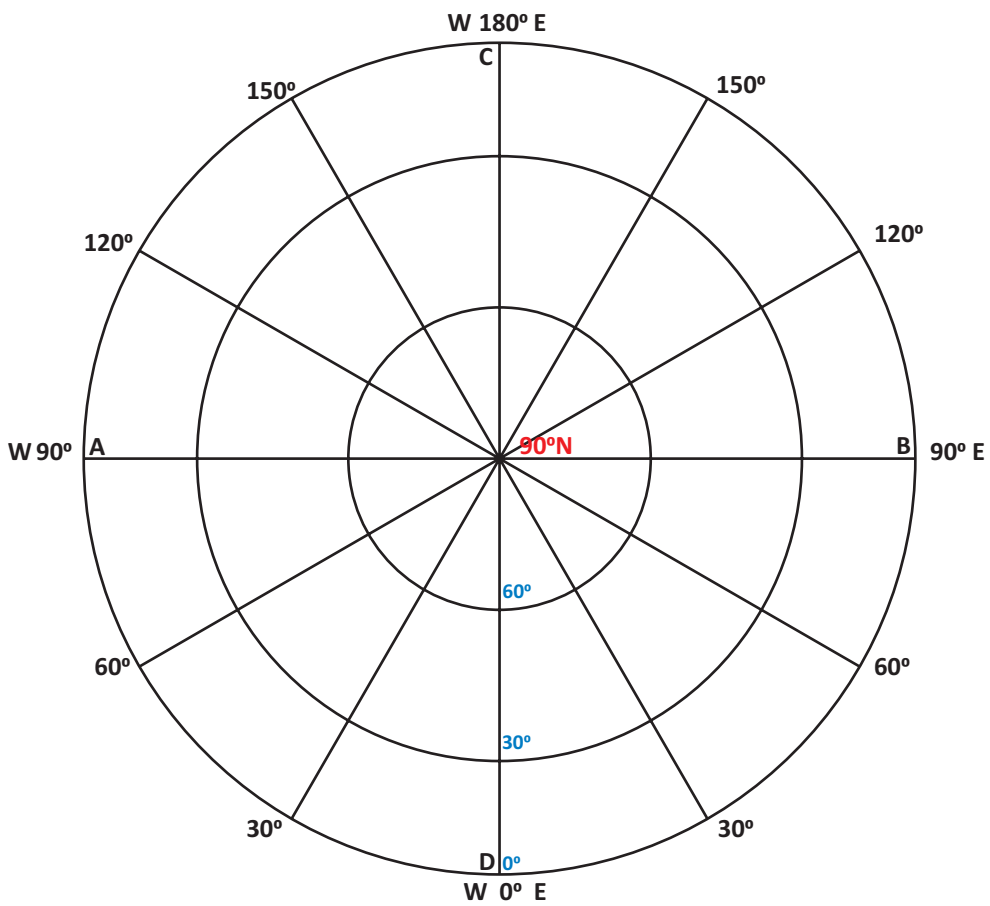
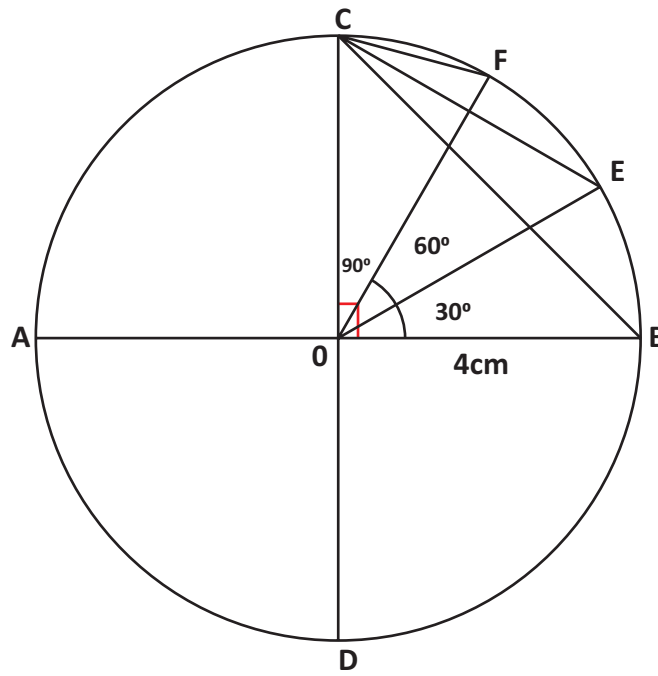

Polar Zenithal Equal area projection



Polar Zenithal Equi-distant Projection

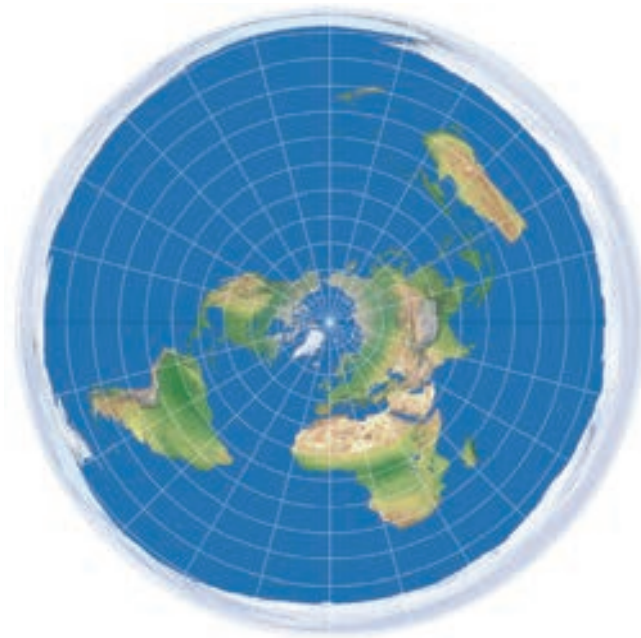

Properties of Polar Zenithal Equi distant Projection

- The pole is a point forming the centre of the projection and the parallels are concentric circles.
- The meridians are straight lines radiating from pole having correct angular distance between them.
- The meridians intersect the parallels at right angles.
- The spacing between the parallels represent true distances, therefore the scale along the meridians is correct.
- The scale along the parallels increases away from the centre of the projection.
- It is used for preparing maps of polar areas for general purposes.

Example 10.4

Construct a Polar zenithal equi-distant projection for the whole globe with a reduced

earth radius of 3cm and the latitudinal and longitudinal interval 30°.

Steps of construction:

- Draw a circle with radius equal to 3cm representing a globe with O as centre.
- Mark the angle of 30° and label it as AOB.
- With radius equal to AB as centre draw a circle with centre N.
- Let CD and AB be the polar and equatorial diameters respectively which intersect each other at right angles at O, the centre of the circle.
- The number of intervals will be $90/30 = 3$.
- Draw 3 concentric circles with N as centre. Mark the meridians radiating from the centre N.
- Using protractor, draw other radii at 30° interval to represent other meridians.
- Complete the projection as shown in Figure.

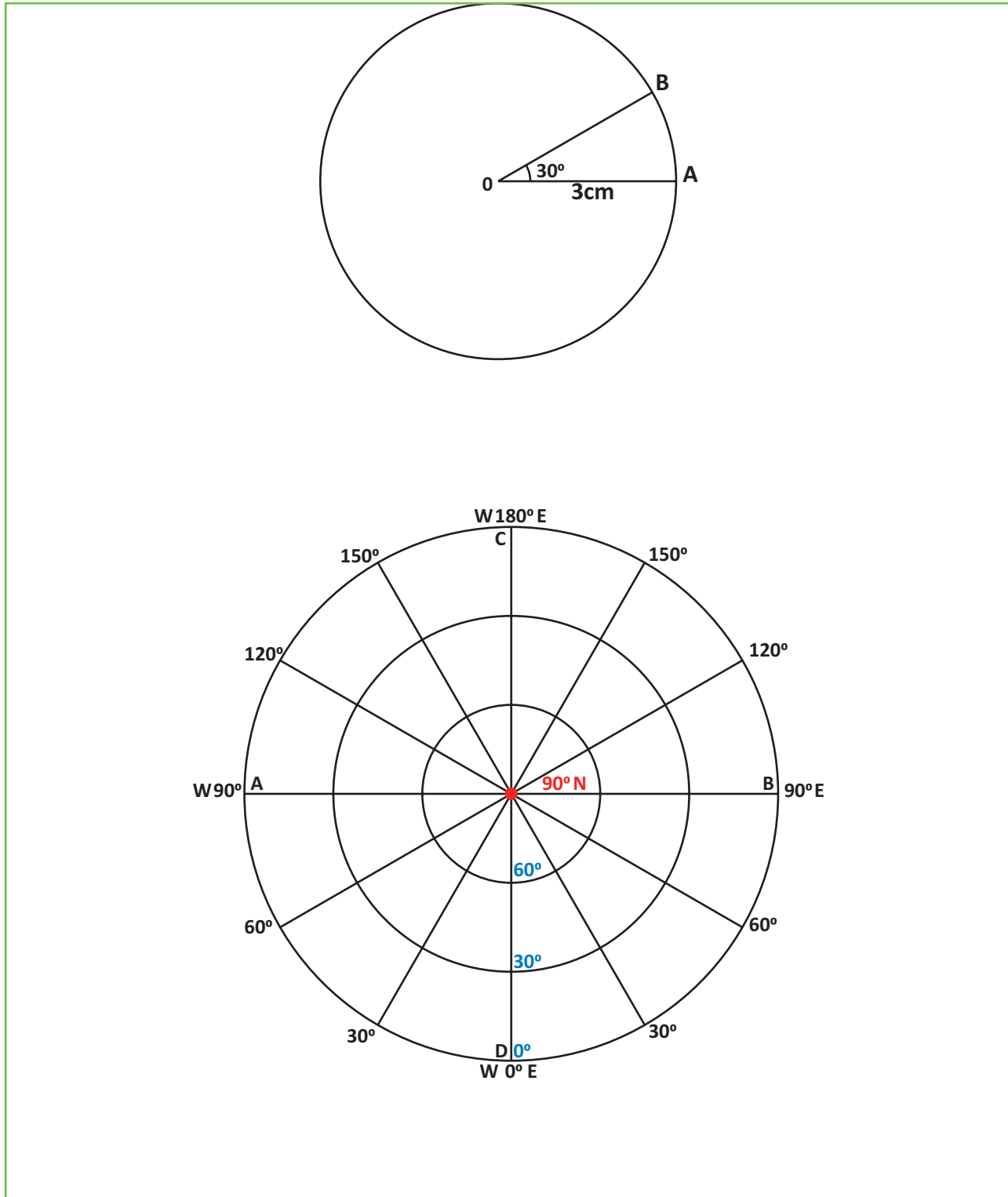

Polar Zenithal Equi distant projection



Exercise

1. Draw a Cylindrical Equal-Area projections for the whole globe with a reduced earth radius of 3 cm and the latitudinal and longitudinal interval at 30° .
2. Draw a Cylindrical Equidistant projections for the whole globe with a reduced earth radius of 3 cm and the latitudinal and longitudinal interval at 30° .
3. Draw Polar zenithal equal area projection for the Southern hemisphere with a reduced earth radius of 3 cm and the latitudinal and longitudinal interval at 30° .
4. Draw Polar zenithal equi distant projection for the Southern hemisphere with a reduced earth radius of 4 cm and the latitudinal and longitudinal interval at 15° .



References

1. Elements of Practical Geography, R.L. Singh and Rana P.B. Singh.
2. Advanced Practical Geography, Piyushkanti Saha and Partha Basu.

UNIT 11

Thematic Mapping

Unit Overview

- 11.1 Introduction
- 11.2 Thematic Map
 - 11.2.1 Dot method
 - 11.2.2 Choropleth method

11.1 Introduction

A thematic map is a map that emphasizes a particular theme or a special topic such as the average distribution of population of an area. It is different from general reference maps because it does not just show general features like rivers, cities, political subdivisions and highways.

11.2 Thematic Map

These thematic maps use a variety of cartographic symbols to depict the spatial pattern of a particular geographic quality or quantity.



In 1854, John Snow, a doctor from London created the first thematic map used for problem analysis when he mapped cholera's spread throughout the city.



Learning Objectives

- Enhance the knowledge about thematic mapping.
- To understand the concepts of thematic maps.
- Realise the importance of the thematic map – Dot and choropleth.
- To interpret a Dot and choropleth map.
- Learn and practice dot map and choropleth map.



Thematic maps emphasize spatial variation of one or a small number of geographic distributions. These distributions may be physical phenomena such as climate or human characteristics such as population density and health issues.

Thematic maps are used to display geographical concepts such as density, distribution, relative magnitudes, gradients, spatial relationships and movements.

Purposes of Thematic Maps

- They provide specific information about particular locations.
- They provide general information about spatial patterns.
- They can be used to compare patterns on two or more maps.

There are five types of thematic map that are particularly useful to decision makers, analysts, storytellers, and others who are looking to draw insights from their data, tell a powerful story, or gain a greater understanding of the world around us. They are choropleth map, isopleth map, proportional symbol map, dot map and chorochromatic map. In this unit, let us learn about dot map and choropleth map in detail.

11.2.1 Dot Method

The dot method is a convenient method of representing absolute numbers on maps. Each dot is assigned with a value and the number of dots, can be placed within an area as per their distribution pattern. This method is useful not only to provide a good visual impression and a realistic distribution pattern but also it helps in understanding correlations.

Uses of dot Method

They are drawn to show the distribution of population, cattle, area under crops, output of commodities, etc., when data is given in absolute figures administrative unit-wise.

Size of dots

Dots should be round and of uniform size. They should be of small size but as small as a fine point. Dots of about 1 to 1.5 mm diameter may

be drawn as they are quite effective. The value given to a dot should be determined carefully and keeping in view the highest and the lowest values.

Placing of dot

The placing of dots should conform to the geographic conditions of a particular area. The knowledge of the geographical conditions of the area is necessary for placing the dots correctly. Sandy, stony and forested areas are naturally unimportant for the production of agricultural crops and human settlements. Marshy areas and areas occupied by lakes, river beds, etc., being negative are left without dots. Unproductive lands are called negative lands. It is better if negative areas are first identified and shaded lightly with a lead pencil. Thus the placing of dots on negative areas can be easily avoided. The areas shaded with pencil are erased with a rubber eraser after the dots have been placed on the map.

Requirements for the preparation of a dot map

To prepare a dot map we need an outline map of the area showing boundaries of the administrative divisions. For the sake of the greater accuracy, it is advisable to have the administrative divisions as small as possible. Topographical sheets, irrigation maps, relief maps, soil distribution maps, rainfall distribution maps, etc., of the area are also useful for drawing a dot map.

Steps to construct a dot map

- Obtain a base map of the area or administrative regions you wish to show.
- Study the data to be mapped and decide on a dot value (should be a rounded number).

- Determine on an appropriate dot shape and size. As a general guide, dots that are too small to produce an overly sparse dot pattern which is not very precise.
- Place the correct number of dots with each administrative boundary as determined in step 2.

Example: 11.1

Construct a dot map to represent population data as given in Table 11.1.

Table 11.1 Population Distribution of selected states of India - 2019

S.No	States	Total Population
1	Andhra Pradesh	52,883,163
2	Telangana	38,472,769
3	Tamil Nadu	76,481,545
4	Karnataka	66,165,886
5	Kerala	35,330,888

Source: Unique Identification Authority of India - Government of India

Construction

Step 1: One dot • = 1,000,000 Persons

Step 2: Calculation of dots

S.No	States	$\frac{\text{Total Population}}{1000000}$	No of Dots
1	Andhra Pradesh	$\frac{52,883,163}{1000000}$	52
2	Telangana	$\frac{38,472,769}{1000000}$	38
3	Tamil Nadu	$\frac{76,481,545}{1000000}$	76
4	Karnataka	$\frac{66,165,886}{1000000}$	66
5	Kerala	$\frac{35,330,888}{1000000}$	35

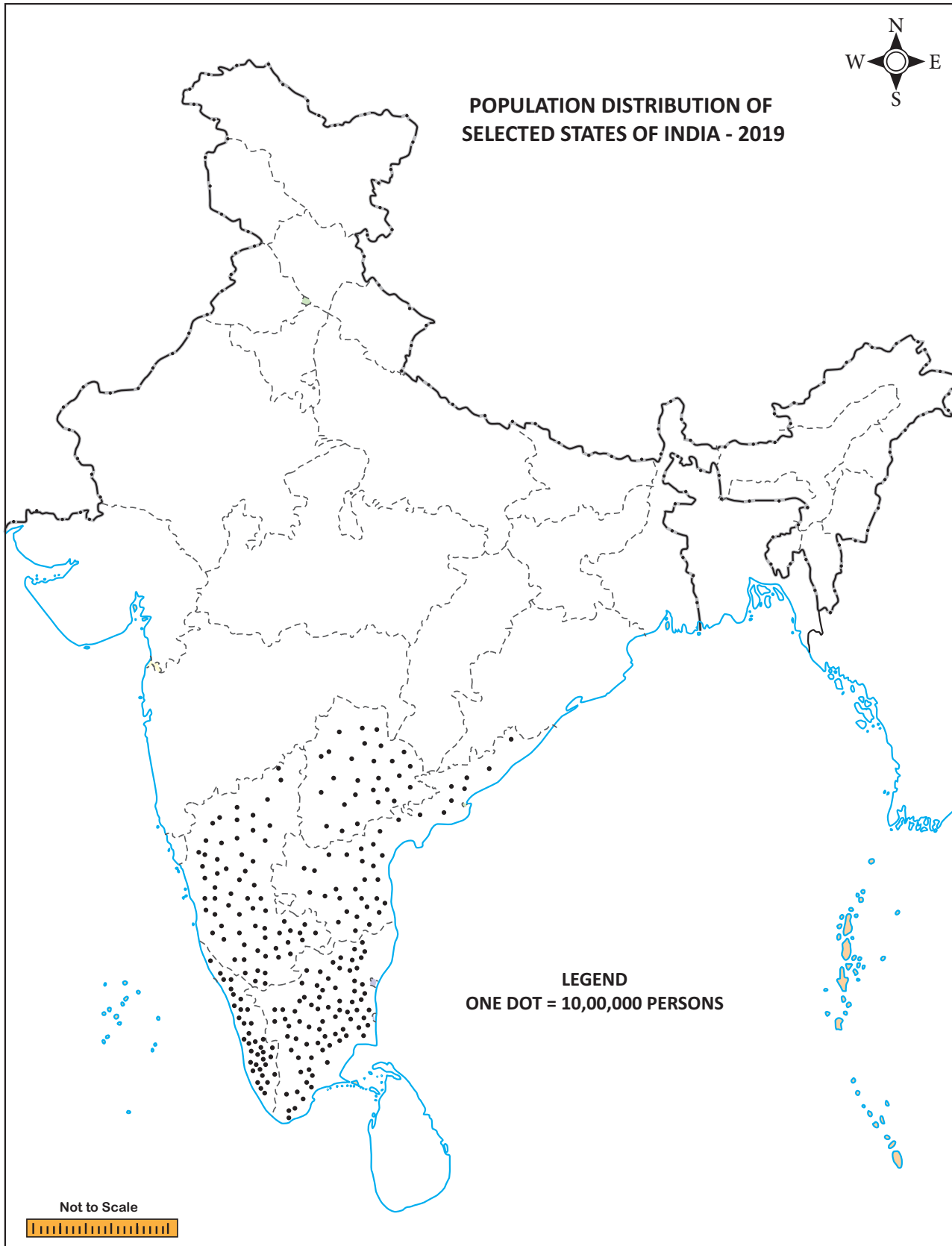

Dot map



11.2.2 Choropleth Method

The choropleth map uses shades or tints to show intensity or distribution of a particular element. It takes into account administrative units which form the basis of spatial distribution of data. That is why shading conforms to administrative units. The density patterns are highlighted by light shading (low density) and dark shading (high density).

Uses of choropleth map

Choropleth maps are drawn to represent densities per unit area within political divisions. Thus, these maps show population per square kilometre or yield per hectare.

The choropleth maps are also drawn to depict the data characteristics as they are related to the administrative units. These maps are used to represent the density of population, literacy, growth rates, sex ratio, etc.

These maps also show percentages, for example, percentage of area under wheat cultivation to the total cropped area.

How to interpret a choropleth

1. Identify the geographic feature or phenomena being mapped.
2. Verify the value of each shade used on the map. This can be done by reading the map's legend.

Example 11.2

Construct a Choropleth map to represent the literacy rates in Tamil Nadu as given in Table 11.2.

3. Identify the scale of the administrative regions shown on the map.
4. Using the key as a guide, identify the areas of the map that share the same colour shading and the same quantity volume of the feature being mapped.
5. Describe the density or concentration of the feature within and between different areas of the map.

Requirement for drawing Choropleth Map

- (a) A map of the area depicting different administrative units.
- (b) Appropriate statistical data according to administrative units.

Steps to be followed

- (a) Arrange the data in ascending or descending order.
- (b) Group the data into 5 categories to represent very high, high, medium, low and very low concentrations.
- (c) The interval between the categories may be identified on the following formulae i.e., $\text{Range}/5$ (Range = maximum value – minimum value).
- (d) Patterns, shades or colour to be used to depict the chosen categories should be marked in an increasing or decreasing order.

Table 11.2 Original Data**Literacy rate of Tamilnadu – 2011**

S.No.	District	Literacy rate
1	Chennai	90.18
2	Kancheepuram	84.49
3	Vellore	79.17
4	Thiruvallur	84.03
5	Salem	72.86
6	Villupuram	71.88
7	Coimbatore	83.98
8	Tirunelveli	82.5
9	Madurai	83.45
10	Tiruchirappalli	83.23
11	Cuddalore	78.04
12	Tiruppur	78.68
13	Tiruvannamalai	74.21
14	Thanjavur	82.64
15	Erode	72.58
16	Dindigul	76.26
17	Virudhunagar	80.15
18	Krishnagiri	71.45
19	Kanyakumari	91.75
20	Thoothukudi	86.16
21	Namakkal	74.63
22	Pudukkottai	77.19
23	Nagapattinam	83.59
24	Dharmapuri	68.54
25	Ramanathapuram	80.72
26	Sivagangai	79.85
27	Thiruvarur	82.86
28	Theni	77.26
29	Karur	75.6
30	Ariyalur	71.34
31	The Nilgiris	85.2
32	Perambalur	74.32

Table 11.3**Table arranged in descending order**

S.No.	District	Literacy rate
1	Kanyakumari	91.75
2	Chennai	90.18
3	Thoothukudi	86.16
4	The Nilgiris	85.2
5	Kancheepuram	84.49
6	Thiruvallur	84.03
7	Coimbatore	83.98
8	Nagapattinam	83.59
9	Madurai	83.45
10	Tiruchirappalli	83.23
11	Thiruvarur	82.86
12	Thanjavur	82.64
13	Tirunelveli	82.5
14	Ramanathapuram	80.72
15	Virudhunagar	80.15
16	Sivagangai	79.85
17	Vellore	79.17
18	Tiruppur	78.68
19	Cuddalore	78.04
20	Theni	77.26
21	Pudukkottai	77.19
22	Dindigul	76.26
23	Karur	75.6
24	Namakkal	74.63
25	Perambalur	74.32
26	Tiruvannamalai	74.21
27	Salem	72.86
28	Erode	72.58
29	Villupuram	71.88
30	Krishnagiri	71.45
31	Ariyalur	71.34
32	Dharmapuri	68.54

Construction

- Arrange the data in descending order as shown above.
- Identify the range within the data. In the present case, the districts with record of the highest and lowest literacy rates are Kanyakumari (91.75%) and Dharmapuri (68.54%) respectively. Hence, the range would be $91.75 - 68.54 = 23.21$.
- Divide the range in to 5 to get categories from very low to very high.
- Determine the number of the categories along with the range of each category.

We will finally get following categories

Categories	Class interval	Districts
Very Low	Below 70	Dharmapuri
Low	70–75	Namakkal, Perambalur, Tiruvannamalai, Salem, Erode, Villupuram, Krishnagiri, Ariyalur.
Medium	75–80	Sivagangai, Vellore, Tiruppur, Cuddalore, Theni, Pudukkottai, Dindigul, Karur.
High	80–85	Kancheepuram, Thiruvallur, Coimbatore, Nagapattinam, Madurai, Tiruchirappalli, Thiruvarur, Thanjavur, Tirunelveli, Ramanathapuram, Virudhunagar.
Very High	Above 85	Thoothukudi, The Nilgiris, Kanyakumari, Chennai.

- Assign shades/pattern to each category ranging from lower to higher values.
- Prepare the map as shown in Figure.

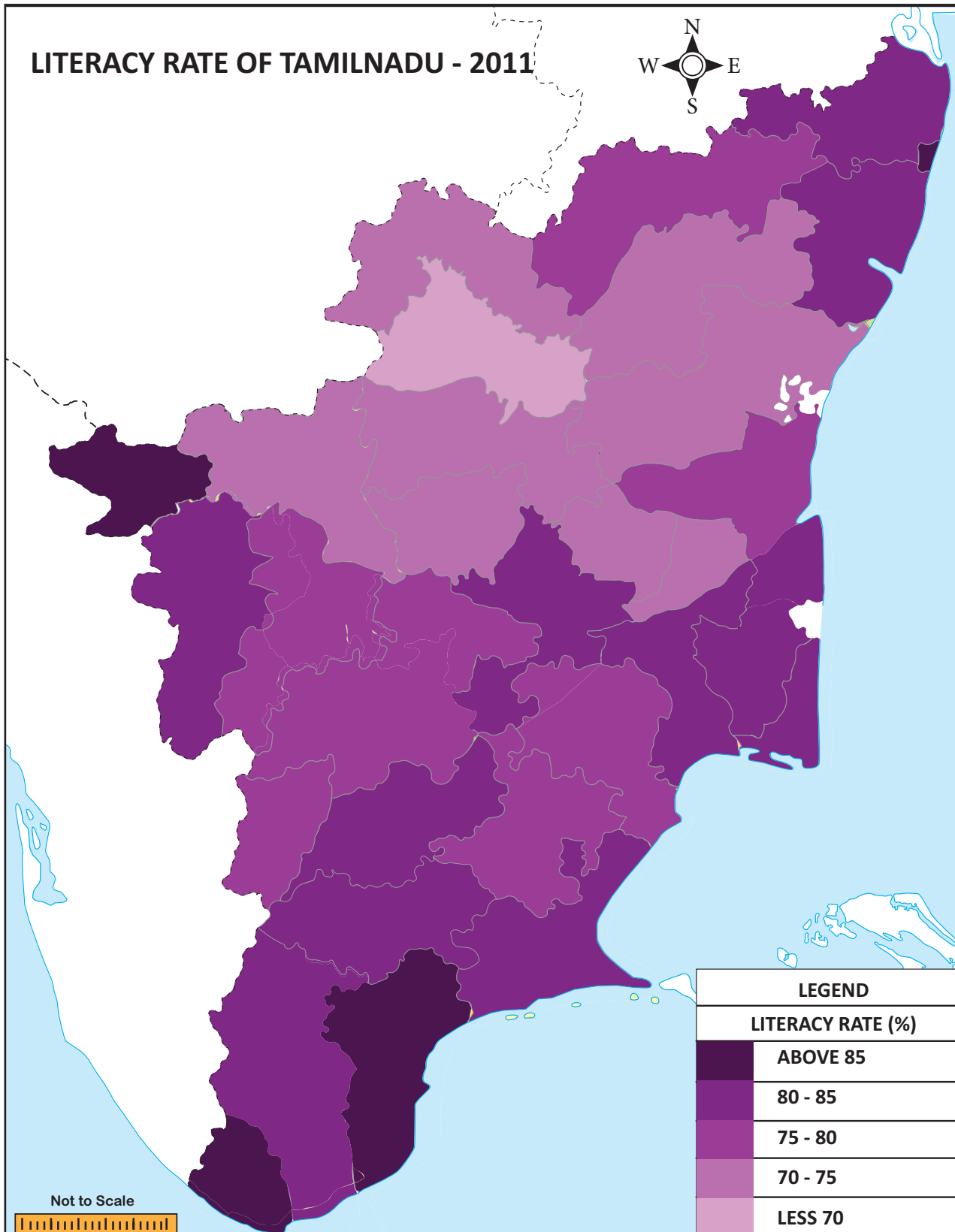

Choropleth map

Exercise

1. Construct a Choropleth map to represent production of paddy in Tamilnadu (2015–2016).

S.NO	DISTRICT	PRODUCTION IN TONNES
1	Chennai	-
2	Kancheepuram	415302
3	Thiruvallur	333203
4	Cuddalore	507130
5	Villupuram	773313
6	Vellore	202224
7	Thiruvannamalai	550738
8	Salem	122541
9	Namakkal	60391
10	Dharmapuri	149426
11	Krishnagiri	102306
12	Coimbatore	7942
13	Tiruppur	48167
14	Erode	146570
15	Tiruchirappalli	244213
16	Karur	52886
17	Perambalur	64208
18	Ariyalur	124179
19	Pudukkottai	258976
20	Thanjavur	636999
21	Thiruvarur	666958
22	Napapattinam	338260
23	Madurai	203670
24	Theni	79374
25	Dindigul	71945
26	Ramanathapuram	303463
27	Virudhunagar	100607
28	Sivaganga	189480
29	Thirunelveli	488445
30	Thoothukkudi	74558
31	The Nilgiris	1418
32	Kannaiyakumari	55789

2. Construct a dot map to represent Area under sugarcane of Selected Districts of Tamilnadu 2015–2016.

S.No	District	Area in Hectares
1	Cuddalore	24443
2	Villupuram	73243
3	Tiruvannamalai	25394
4	Namakkal	14268
5	Erode	22332



References

1. Fundamentals of Practical Geography
Dr.L.R.Singh, Sharda pastak Bhavan,
Allahabad.
2. Practical Geography A Systematic Approach,
Ashis Sarkar.

UNIT 12

Representation of Geographical Data



Unit Overview

- 12.1 Introduction
- 12.2 Classification of statistical diagrams
 - 12.2.1 Line Diagram
 - 12.2.2 Bar Diagram
 - 12.2.3 Pie Diagram

12.1 Introduction

Economists, statisticians, and geographers make use of statistical facts and data in their respective fields. Climatic data like temperature, pressure, rainfall, etc., may be represented by diagram such as isotherms, isobars and isohyets respectively. Besides the tabular form, the data may also be presented in some graphical or diagrammatic form. Population, climatic, and Socio economic data can be represented visually for better understanding in the form of graphs, diagrams, charts and maps. Thus, geographical data needs to be scientifically visualised for appropriate cartographic communication. Therefore, cartographic presentation of geographical data is important to explore the nature of data, their pattern of variations over time and space, to analyse the data set, and to identify and classify the real world objects.

We study climatic, economic and population data in geography. The numerical data or facts when collected in a systematic



Learning Objectives

- Identify various types of Geographical data.
- Understand various methods of drawing geographical data.
- Analyse the various methods of constructing diagram suitable for particular data.



manner to serve some purpose and presented in a tabulated form they are called statistics.

The diagrams representing statistical data are known as statistical diagrams. Geometrical figures such as bars, rectangles, squares, circles, cubes, sphere, etc., and curves or lines are used to represent statistical data diagrammatically. These diagrams serve the following purposes:

1. They enable us to compare figures at a glance.
2. They cast easily memorable impression on the mind.
3. They enable us to analyse the data and draw inference easily.

12.2 Classification of statistical diagrams

There are three classes of statistical diagrams. They are as follows;

- One-dimensional statistical diagrams** such as line graph, poly graph, bar diagram, histogram, and star diagram. etc., in these diagrams quantities are represented by the line, length of bars and length of radiating lines in a star diagram.
- Two-dimensional statistical diagrams** are also known as area diagram such as squares, rectangles and circles. Divided squares, divided circles also called as pie diagrams are two dimensional diagrams.
- Three-dimensional statistical diagrams** are also called volume diagram examples cube, block piles and spherical diagrams.

We will discuss the following diagrams alone

Line graphs

Bar diagrams

Pie diagram

12.2.1 Line Graph

The line graphs are usually drawn to represent the time series data related to the temperature, rainfall, population, birth rates and the death rates.

Uses of line-graphs

Line-graphs are commonly used for representing

- Climatic data pertaining to elements such as temperature, pressure, humidity, etc.,

Example 12.1

Construct a line graph to represent the data as given in Table 12.1

Table 12.1: Literacy Rate of India – 1901 to 2011

Year	1901	1911	1921	1931	1941	1951	1961	1971	1981	1991	2001	2011
Literacy rate in %	5.35	5.92	7.16	9.50	16.10	16.67	24.0	29.45	36.23	42.23	64.83	74.04

Source: Census report 2011

- Population data such as growth of population, birth rate, death rate, etc, and
- Economic data such as crop yield, minerals extraction, production of industrial goods over a period of time etc.

Simple line graph

A simple line-graph is a line or a curve drawn by joining together, points plotted with the help of two co-ordinates i.e. is a vertical axis and horizontal scale. It represents the successive changes in the value of one variable over a certain period of time.

How to construct a Line Graph

Line graphs are very easy to construct on graph paper.

- Draw a horizontal line to represent x-axis and vertical line to represent y-axis. The point where x-axis and y-axis intersect at right angles is the starting point. Normally assigned the value zero (0).
- Next add label and scale for both axes.
- After that, plot your data points.
- Next draw a line through the plotted data points.
- Finally add a title.

Let us see some of the solved examples given below.

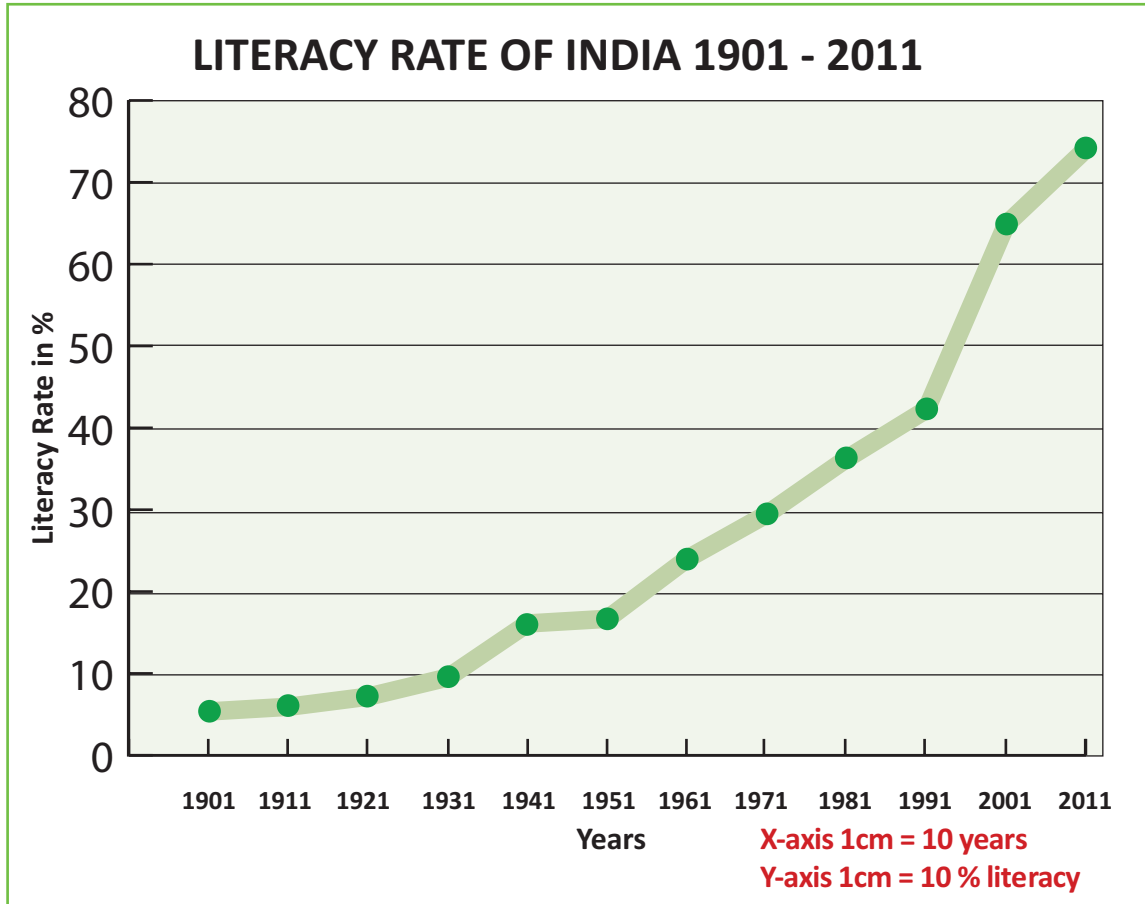

Simple line graph

Polygraph

Polygraph is a line graph in which two or more variables are shown by an equal number of lines for an immediate comparison, such as the growth rate of different crops like rice, wheat pulses or the birth rates, death rates and life expectancy or sex ratio in different states or countries. A different line pattern such as straight line (—), broken line (---), dotted line (.....) or a combination of dotted and broken line (-.-.-) or line of different colours may be used to indicate the value of different variables.

Example 12.2

Construct a polygraph to represent the data as given in Table 12.2.

Table 12.2 Urban Population in percentage of selected states of India

States	1971	1981	1991	2001	2011
Tamil Nadu	30.26	32.65	34.15	44.04	48.45
Kerala	16.24	18.74	26.39	25.96	47.72
Bihar	10	12.47	13.14	10.45	11.3

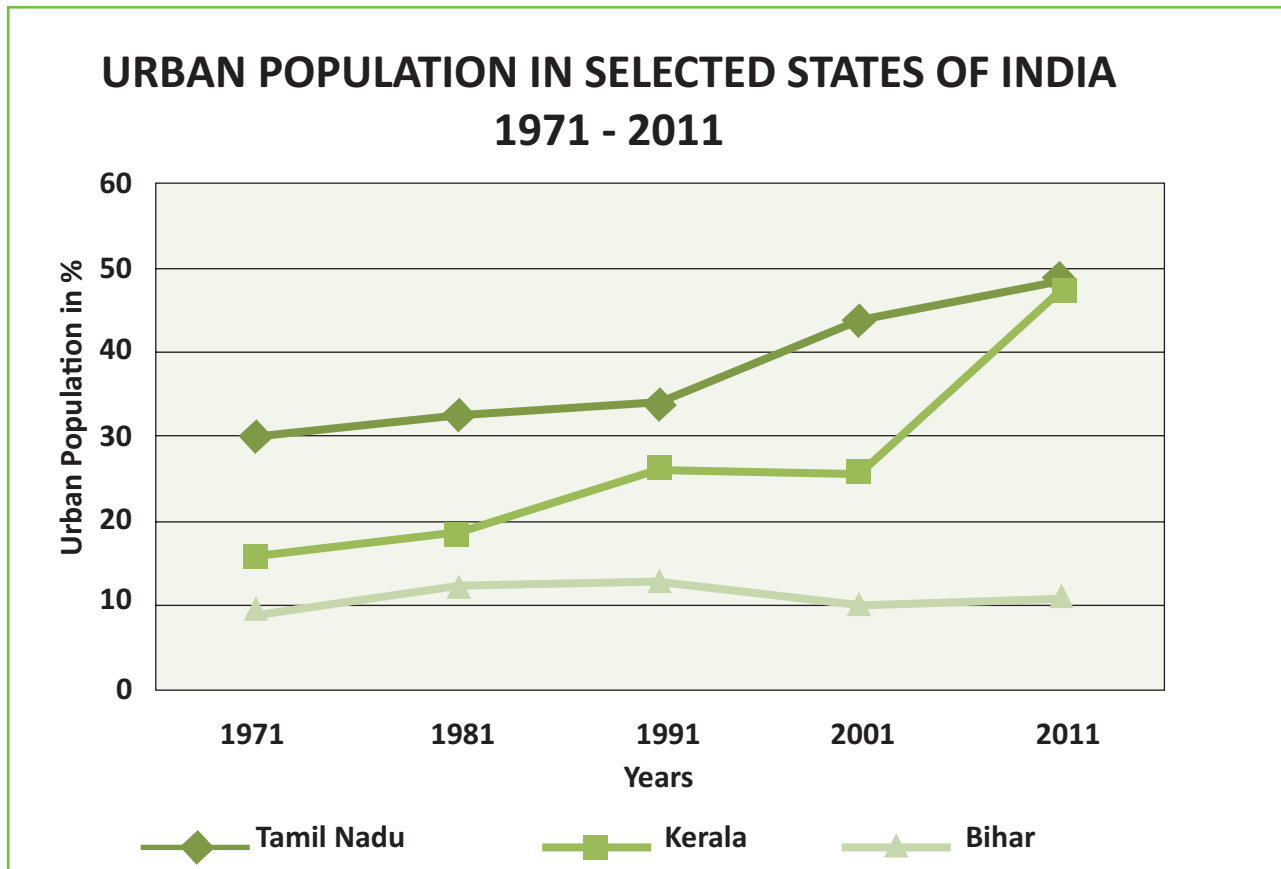

12.2.2 Bar Diagram

In Bar diagrams quantities are represented by bars, the length of which are proportional to the quantities, they represent. The diagrams which represent quantities by bars are known as bar diagrams, columnar diagrams or bar-graphs. When compared with other diagrams, the bar diagram gives more accurate idea of the size of the quantities represented by them. They are also drawn on maps for showing regional variations in the distribution of a quantity. The bars are either vertical or horizontal.

- The width of all the bars or columns should be similar.
- All the bars should be placed on intervals of equal distance.
- Bars may be shaded with colours or patterns to make them distinct and attractive.

Kinds of Bar Diagrams

1. Simple bar diagram.
2. Comparative or multiple bar diagram.
3. Compound or sub-divided bar diagram.
4. Percentage bar diagram.

We shall discuss Simple Bar Diagram and Multiple Bar Diagram in this unit.

Simple Bar Diagram

A simple bar diagram consists of a series of bars each of which shows total value of only one variable. We can represent for example the total population of different states of a country for a particular year, the annual production of wheat, rice, cotton for a particular place etc., and monthly rainfall for 12 months of the year. A simple bar diagram is constructed for an immediate comparison. It is advisable to arrange the given data set in an ascending or descending order and plot the data variables accordingly.

Construction of Simple Bar Diagram

Solution:

We represent the above data by simple bar diagram in the following manner:

Step-1: Time (Years) is marked along the X-axis and labelled as 'Year'.

Step-2: Production Cost is marked along the Y-axis and labelled as 'Production Cost' (in lakh of rupees).

Step-3: Vertical rectangular bars are erected for each year marked on x-axis and the height of each bar is proportional to the value of the respective production cost.

Step-4: Simple Vertical bars are filled with the same colours.

Example 12.3

Construct a simple bar diagram to represent the data given in Table 12.3.

Table 12.3 Major Rice producing countries - 2012

Country	Production (Thousand Tonnes)
China	197221
India	120620
Indonesia	66412
Bangladesh	49355
Vietnam	39989
Myanmar	33204
Thailand	31597
Philippines	15772
Brazil	11309
U.S.A	11027
Pakistan	7235

Source: F.A.O. Yearbook of Agricultural Statistics, 2012

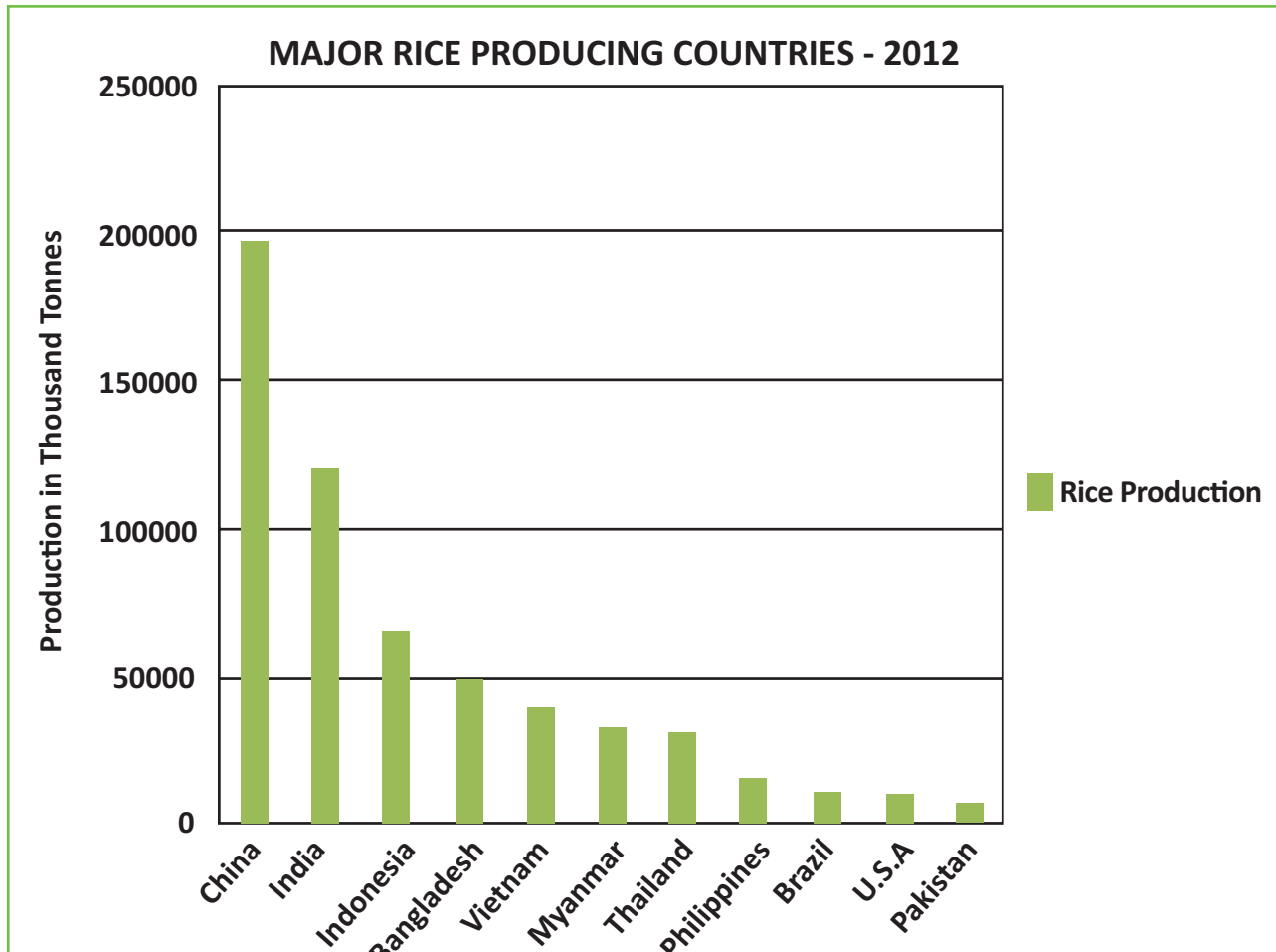

Simple Bar Diagram

Multiple bar Diagram

Multiple bar diagrams are constructed to represent two or more variables for the purpose of comparison. For example, a multiple bar diagram may be constructed to show proportion of males and females in the total,

rural and urban population or the share of canal, tube well and well irrigation of the total irrigated area in different states or yield of rice, wheat sugar cane, coffee in the different states of a country, etc.

Example 12.4

Construct a Multiple Bar diagram to represent the data given in Table 12.4.

Table 12.4: Population of India from 1951-2011

Year	Male	Female	Total population
1951	185,528,462	175,559,628	361,088,090
1961	226,293,201	212,941,570	439,234,771
1971	284,049,276	264,941,570	548,159,652
1981	353,374,460	329,954,637	683,329,097
1991	439,358,440	407,062,599	846,421,039
2001	532,223,090	496,514,346	1,028,737,436
2011	623,724,248	586,469,174	1,210,193,422

Source: Office of the Registrar General, India.

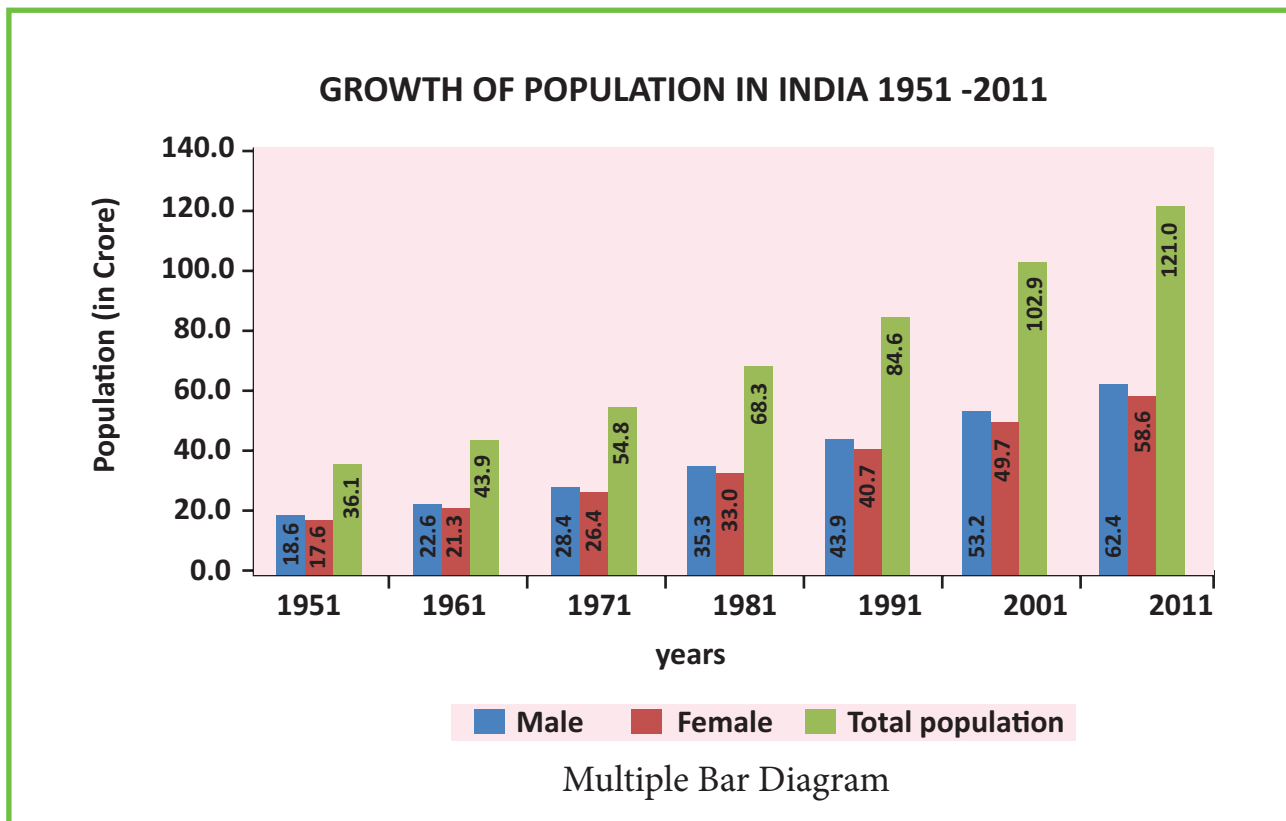

12.2.3 Pie Diagram

The Pie diagram is a circular diagram. A circle which has 360° is divided into different sectors. Angles of the sectors, subtending at the center, are proportional to the magnitudes of the frequency of the components. When a circle is sub-divided into various component sectors, it is called a Pie diagram.

How to construct a pie diagram?

The following procedure can be followed to draw a Pie diagram for a given data:

1. Draw a circle by using a particular radius.
2. The proportional values of various components should be converted into degrees.
3. The angles are obtained by the following formula

$$\text{Angle value} = \frac{\text{Value of component}}{\text{Total value}} \times 360$$

Example 12.5

Construct a Pie diagram to represent the data given in **Table 12.5**.

Table 12.5 Percentage of area under wheat cultivation

Continent	Area in %
North America	12.7
South America	4.07
Europe	25.75
Asia	46.85
Oceania	6.25
Africa	4.38

Continent	Area in %	Calculation	Degree
North America	12.7	$\frac{12.7}{100} \times 360^\circ = 45.72$	46°
South America	4.07	$\frac{4.07}{100} \times 360^\circ = 14.65$	15°
Europe	25.75	$\frac{25.75}{100} \times 360^\circ = 92.7$	92°
Asia	46.85	$\frac{46.85}{100} \times 360^\circ = 168.66$	169°
Oceania	6.25	$\frac{6.25}{100} \times 360^\circ = 22.5$	22°
Africa	4.38	$\frac{4.38}{100} \times 360^\circ = 15.76$	16°
Total	100		360°

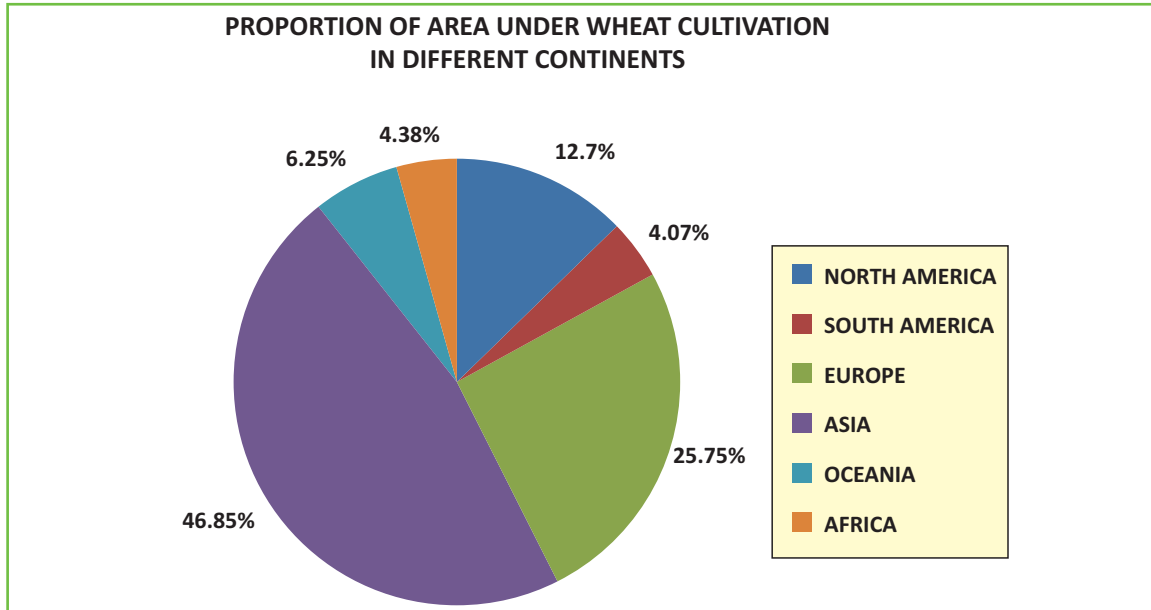

Pie diagram

Exercise

1. Represent the following data using simple line graph.

Station: Vellore

	Jan	Feb	Mar	Apr	May	Jun	Jul	Aug	Sep	Oct	Nov	Dec
Temperature in ° C	21	22	24	26	28	27	26	25	25	24	23	21
Rainfall in mm	4	9	10	28	94	71	96	122	172	195	122	58

2. Represent the following data with poly graph.

Temperature in ° C	Jan	Feb	Mar	Apr	May	Jun	Jul	Aug	Sep	Oct	Nov	Dec
Cuddalore	25	26	28	30	31	30	30	29	29	27	26	25
Coimbatore	25	26	27	28	28	26	25	25	26	26	25	25
Karur	23	24	26	27	27	25	25	24	25	24	23	23

3. Draw a simple bar diagram for the following data.

Manganese - ore production in 2016	
Country	Production in Million Tonnes
South Africa	4,754,560
Australia	2,388,500
China	2,150,000
Gabon	1,658,500
Brazil	1,141,684

4. Represent the following data using Multiple Bar diagram.

Energy Generated - India in billion KwH

Year	Hydro Electric	Thermal	Nuclear
2008-2009	110	616	14
2009-2010	104	677	18
2010-2011	114	704	26

5. Represent the following data by a Pie Diagram.

Average Yield of Rice - 2014-2015

State	Yield Kg/Hec
Tamil Nadu	3191
Karnataka	2827
Kerala	2818
Uttar Pradesh	2082
West Bengal	2731



References

1. Elements of Practical geography, R. L. Singh and Rana P.B. Singh.
2. Advanced Practical geography, Pijushkanti Saha and Partha Basu.

UNIT 13

Statistical Techniques

Unit Overview

- 13.1 Introduction
- 13.2 Role of statistics in geography
- 13.3 Types of Data
- 13.4 Methods of collection of Data
- 13.5 Organisation and Classification of Data
- 13.6 Statistical techniques measures of central tendency

13.1 Introduction

Statistics is a branch of science which deals with quantitative data. Actually statistics includes in four processes.

1. Collection of Data
2. Presentation of Data
3. Analysis of Data
4. Interpretation of Data

13.2 Role of statistics in geography

Statistical techniques and procedures are applied in all fields of academic research; wherever data are collected and summarized or wherever any numerical information is analyzed or research is conducted, statistics are needed for sound analysis and interpretation of results.

Learning Objectives

- To Understand the concepts of geographical data
- To know the various types and methods of data collection.
- To analyse and interpret various data used in geography
- To develop and understand the measures of central tendency



Geographers use statistics in numerous ways

- To describe and summarize spatial data.
- To make generalizations concerning complex spatial patterns.
- To estimate the probability of outcomes for an event at a given location.
- To use samples of geographic data to infer characteristics for a larger set of geographic data (population).
- To determine if the magnitude or frequency of some phenomenon differs from one location to another.
- To learn whether an actual spatial pattern matches some expected pattern.

For example, a student studying the annual rainfall in a particular region will first of all

collect the data regarding rainfall of the region. Then he will summarize the collected data in some table or diagram to show the desired results.

13.3 Types of Data

Data can be primarily divided into two types – qualitative data and quantitative data. Qualitative data only describes an item example coconut tree, palm tree, etc or language spoken – Tamil, Telugu, Hindi, English, etc. Quantitative data on the other hand has numerical value to the item, example, marks obtained - 45, 70, 60, 90, 25, etc.

Data can also be divided based on the source or method of collection as the primary data and secondary data. The primary data are those statistical materials which the investigator collects by going from door to door for the purpose of his/her study. On the other hand, the secondary data refer to already collected and recorded data which the investigator had collected from published or unpublished sources.

13.4 Methods of collection of Data

Methods of Primary data collection

1. Direct personal investigation (interview)
2. Indirect oral investigation
3. Questionnaire Method

Methods of Secondary data collection

1. Published Sources
2. Unpublished Sources

13.5 Organisation and Classification of Data

After collecting data it has to be classified and arranged for further statistical analysis. The data classified is large in quantity needs to be reduced for further analysis. This leads to organization of data.

Following steps are important in organization of data

Finding Range

While organizing the data, it is necessary to find out the highest and lowest number (maximum and minimum value) from the given data. The difference between these two extreme values is called range.

$$\text{Range} = \text{Highest value} - \text{Lowest value.}$$

Example

Find out the range from the following data 2, 6, 4, 9, 12, 8, 5, 8. In this case, highest value is 12 and lowest value is 2, and the range is $12 - 2 = 10$.

Frequency array

In statistics, array refers to some kind of orderly arrangement. When the numerical raw data is arranged in ascending or descending order, it is called array.

Frequency distribution

It is an arrangement of data into classes. Following technical terms are important for frequency distribution.

1. Class

It is a group which divides the variable into parts and forms a set of given frequency.

Example

CLASS INTERVAL	TALLY	FREQUENCY
0-10		1
10-20		5
20-30		12
30-40		8
40-50		4
	SUM	30

2. Class limit

The extreme values of the classes or groups are called the class limit. Each class has lower limit (minimum value) and upper limit (maximum value).

For example in the class 10 – 20, the lower limit is 10 and upper limit is 20.

3. Midpoint

It is obtained by dividing the sum of lower limit and upper limit by 2.

For example in the class 10 – 20, the midpoint is $\frac{10+20}{2} = 15$

4. Class interval

It is the difference between the upper and lower limit of a class.

For example:

In the class 10 – 20,

The class interval is $20 - 10 = 10$.

5. Tally Marks

Tally marks usually come in group of 5. For every observation, we put vertical bars called tally marks. After 4 bars we put a cross stroke for 5th observation. It helps in easy counting of the frequencies.

6. Class Frequency

The number of observations included in each class is the class frequency or sum of tally marks of that particular class.

7. Total Frequency

It is an aggregate of all class frequencies. It is the sum of all observations.

13.6 Statistical techniques - Measures of central tendency

One of the most important objectives of statistical analysis is to get one single value that describes the characteristics of the entire data. A common word used for measures of central tendency is average. For example, if we collect the

heights of 5000 students of a college, we will have 5000 figures. The person's mind is not capable of registering all the data at a time. So we need a single figure which represents the whole data. This single figure is known as average.

Since an average represents the entire data, its value lies somewhere in between the two extremes i.e. the largest observation and the smallest observation. For this reason the average is frequently referred as measure of central tendency.

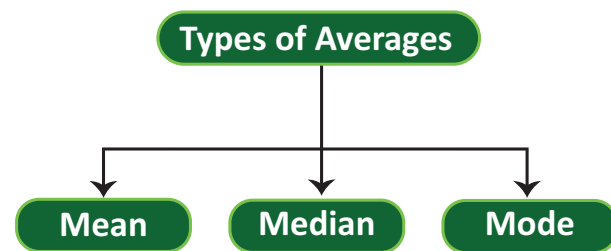

Mean

Mean is defined as the value obtained by dividing sum of values of all the given items by the number of items. It is also called as arithmetic mean.

Formula

$$\text{Mean} = \frac{\text{Sum of the values of all items}}{\text{Total number of items}}$$

Mathematically it can be shown as

$$\bar{X} = \frac{X_1 + X_2 + X_3 + \dots + X_n}{N}$$

$$\bar{X} = \frac{\sum X}{N}$$

$$\bar{X} = \text{Mean}$$

$$\sum X = \text{Sum of the Values of all items}$$

$$N = \text{Total number of items}$$

Calculation of Mean

Example 13.1

The following are the monthly average temperature data of Cuddalore District. Find the mean annual temperature.

Cuddalore

Temperature ^o C	Jan	Feb	Mar	April	May	June	July	Aug	Sep	Oct	Nov	Dec
	25.3	26.58	28.46	30.61	31.32	30.75	30	29.34	29.03	27.89	26.45	25.36

Solution:**Formula:**

$$\bar{X} = \frac{\sum X}{N}$$

$$\bar{X} = \frac{25.3+26.58+28.46+30.61+31.32+30.75+30+29.34 + 29.03+27.89+26.45+25.36}{12}$$

$$\bar{X} = \frac{341.09}{12}$$

$$\bar{X} = 28.42$$

Answer:

The Mean annual temperature of Cuddalore district is 28.42

Calculation of Mean for Grouped Data or Continuous Series

Formula:

$$\bar{X} = A + \frac{\sum fd}{N} \times i$$

Where

A = Assumed mean

f = frequency

i = class size

d = deviation from assumed mean

N = Total

$$d = \frac{x - A}{i}$$

Example 13.2

Calculate the mean for the following data of heights of the plants in a garden

Heights in cms	10-20	20-30	30-40	40-50	50-60
No. of plants	5	15	10	15	5

Solution:

Heights in cms X	No of Plants F	Mid point x	A = 25 i = 10 $d = \frac{x - A}{i}$	fd
10 - 20	5	15	-1	-5
20 - 30	15	25 A	0	0
30 - 40	10	35	1	10
40 - 50	15	45	2	30
50 - 60	5	55	3	15
	N = 50			$\Sigma fd = 55 - 5 = 50$

A = 25 , $\Sigma fd = 50$, N = 50, i = 10

Formula:

$$\bar{X} = A + \frac{\sum fd}{N} \times i$$

$$\bar{X} = 25 + \frac{50}{50} \times 10$$

$$\bar{X} = 25 + 10$$

$$\bar{X} = 35$$

Median:

Median is the middle value of a series arranged in any order – ascending or descending. Median divides the series in to two equal parts.

Calculation of Median**Example 13.3**

The following are the monthly minimum temperature of Chennai District. Find the median.

Chennai

Minimum Temperature ° C					
Jan	21.2	May	28	Sep	25.6
Feb	22.2	June	27.5	Oct	24.6
Mar	24.2	July	26.4	Nov	23.1
April	26.6	Aug	25.9	Dec	21.9

Solution:**Step 1:**

Arrange the data in Ascending Order

1	2	3	4	5	6	7	8	9	10	11	12
21.2	21.9	22.2	23.1	24.2	24.6	25.6	25.9	26.4	26.6	27.5	28

Step 2:**Formula**

$$M = \text{Value of the } \left(\frac{N+1}{2}\right)^{\text{th}} \text{ item}$$

$$M = \text{Value of the } \left(\frac{12+1}{2}\right)^{\text{th}} \text{ item}$$

$$M = \text{Value of the } \left(\frac{13}{2}\right)^{\text{th}} \text{ item}$$

$$M = \text{Value of the } 6.5^{\text{th}} \text{ item}$$

$$M = \frac{\text{Size of } 6^{\text{th}} \text{ item} + \text{size of } 7^{\text{th}} \text{ item}}{2}$$

$$M = \frac{24.6 + 25.6}{2}$$

Answer: $M = 25.1$

Calculation of Median for Grouped Data or Continuous Series

Example 13.4

Calculate the median for the following data

Literates by age in 2001

Age group	Literacy in %
5 – 10	22.3
10 – 15	81.7
15 – 20	79.3
20 – 25	73.2
30 – 35	64.5
35 – 40	50

Solution:

Age group	Frequency f	Cumulative Frequency cf
5 – 10	22.3	22.3
10 – 15	81.7	104
15 – 20	79.3	183.3
20 – 25	73.2	256.5
30 – 35	64.5	321
35 – 40	50	371
	N = 371	

→ Median class

Calculation of Median Class

$$N = 371, \left(\frac{N}{2}\right) = \left(\frac{371}{2}\right) = 185.5$$

Class corresponding to 185.5 is **20-25** i.e. the Median Class

Formula

$$\text{Median} = l + \frac{\frac{N}{2} - m}{f} \times c$$

where

- l = Lower limit of the median class
- N = Total Numbers of frequency
- f = Frequency of the median class
- m = Cumulative frequency of the class preceding the median class
- c = The class interval of the median class.

Formula

$$\text{Median} = l + \frac{\frac{N}{2} - m}{f} \times c$$

where $l = 20$, $f = 73.2$, $m = 183.3$, $c = 5$

$$\text{Median} = 20 + \left(\frac{185.5 - 183.3}{73.2} \right) \times 5$$

$$\text{Median} = 20 + \left(\frac{2.2}{73.2} \right) \times 5$$

$$\text{Median} = 20 + (0.03 \times 5)$$

$$\text{Median} = 20 + 0.15$$

Answer: Median = 20.15

Mode

Mode is that value which occurs most frequently in a set of observation or the item which repeats itself the greatest number of times

Calculation of Mode**Example 13.5**

Calculate mode for the following data

Station: Cochin

Direction	% of days wind blowing
N	2
NE	10
E	10
SE	6
S	25
SW	25
W	5
NW	7
Calm	10

Solution:

From the data 25 is repeated 3 times. Hence the Mode is 25

Answer: Mode = 25

Calculation of mode for Grouped Data

Example 13.6

Calculate the mode for following data

Daily Wages	No of Workers
0 – 10	3
10 – 20	5
20 – 30	7
30 – 40	10
40 – 50	12
50 – 60	15
60 – 70	12
70 – 80	6
80 – 90	2
90 – 100	8

Solution

Daily Wages	No of Workers
0 – 10	3
10 – 20	5
20 – 30	7
30 – 40	10
40 – 50	12 f_0
50 – 60	15 f_1
60 – 70	12 f_2
70 – 80	6
80 – 90	2
90 – 100	8

→ Modal class

Highest Frequency = 15

Therefore 50 – 60 is the modal class

Formula

$$\text{Mode} = l + \frac{f_1 - f_0}{2f_1 - f_0 - f_2} \times c$$

Modal class is the class which has maximum frequency.

f_1 = frequency of the modal class

f_0 = frequency of the class preceding the modal class

f_2 = frequency of the class succeeding the modal class

c = width of the class limits

l = lower limit of mode interval

$$l = 50, f_0 = 12, f_1 = 15, f_2 = 12$$

$$\text{Mode} = l + \frac{f_1 - f_0}{2f_1 - f_0 - f_2} \times c$$

$$\text{Mode} = 50 + \left(\frac{15 - 12}{2 \times 15 - 12 - 12} \right) \times 10$$

$$\text{Mode} = 50 + \left(\frac{3}{30 - 24} \right) \times 10$$

$$\text{Mode} = 50 + \left(\frac{30}{6} \right)$$

$$\text{Mode} = 50 + 5$$

Answer: Mode = 55

Exercise

- The following are the monthly average rainfall of Chennai district. Find the mean, median and mode.

Chennai

Rainfall in mm	Jan	Feb	Mar	April	May	June	July	Aug	Sep	Oct	Nov	Dec
	15.54	10.44	12.48	20.96	57.1	41.24	64.4	99.28	147.17	204.22	165.07	133.76

- Calculate the mean, median and mode for the following data relating to the monthly income of workers in a factory

Income in thousands	15-25	25-35	35-45	45-55	55-65	65-75	75-85
No of persons	6	11	7	4	4	2	1

- Calculate mean, median and mode for the following data.

Annual rainfall in cms	0-25	25-50	50-75	75-100	100-125	125-150	150-175	175-200
Area in Sq.m	300	460	650	730	1200	1900	1500	660



References

- Elements of Practical Geography, R.L. Singh and Rana P.B. Singh.
- Advanced Practical Geography, Piyushkanti Saha and Partha Basu.

A-Z

GLOSSARY



<i>Adaptation</i>	தழுவல்
<i>Age sex pyramid</i>	பாலின வயது பிரமிடு
<i>Anthropologist</i>	மானிடவியலார்
<i>Artificial Intelligence</i>	செயற்கை நுண்ணறிவு
<i>Aerosol</i>	தூசுப்படலம்
<i>Satellite Navigation Experimental System</i>	செயற்கைக்கோள் ஊடுருவல் சோதனை முறைமை
<i>Birth Rate</i>	பிறப்பு விகிதம்
<i>Central Business District</i>	மத்திய வணிக மையம்
<i>Conurbation</i>	நகரக் குழுமம்
<i>Culture</i>	கலாச்சாரம்
<i>Cultural Diffusion</i>	கலாச்சார பரவல்
<i>Custom</i>	வழக்கம்
<i>Cultural Traits</i>	கலாச்சாரக் கூறுகள்
<i>Dependency ratio</i>	சார்புநிலை விகிதம்
<i>Diaspora</i>	புலம்பெயர்தல்
<i>Electromagnetic radiation</i>	மின்காந்த கதிர்வீச்சு
<i>Ecumene</i>	உலகின் குடியிருப்புப் பகுதிகள்
<i>Earth summit</i>	புவி உச்சி மாநாடு
<i>Environmental Impact Assessment</i>	சுற்றுச்சூழல் பாதிப்பு மதிப்பீடு
<i>Ethnicity</i>	இனம்
<i>Frontier</i>	எல்லை
<i>Herbicides</i>	களைக்கொல்லிகள்
<i>Heat wave</i>	வெப்ப அலை

<i>Heartland</i>	மையப்பகுதி
<i>Image Restoration</i>	பட மீட்சி
<i>Meta data</i>	மெட்டா தரவு
<i>Missile Defense Shield</i>	ஏவுகணை பாதுகாப்பு கேடயம்
<i>Microprocessors</i>	நுண்ணெயலிகள்
<i>Megalopolis</i>	மீப் பெருநகர்
<i>National Watershed Development Project for Rain-fed Areas</i>	மானாவாரிப் பகுதிகளுக்கான தேசிய நீர்ப்பாசன அபிவிருத்தி திட்டம்
<i>poverty</i>	ஏழ்மை
<i>Precision Agriculture</i>	துல்லிய வேளாண்மை
<i>Relic</i>	மிகுந்திருப்பது
<i>Rill</i>	சிற்றாறு
<i>robot</i>	இயந்திர மனிதன்
<i>Suffocation</i>	மூச்சுத்திணறல்
<i>surveillance</i>	கண்காணிப்பு
<i>Sustainable development</i>	பேணத்தகுந்த வளர்ச்சி
<i>Transhumance</i>	கால்நடைகளைப் பருவ காலத்திற்குத் தக்கவாறு மேய்ச்சலுக்காக இடம் மாற்றிச் செல்லுதல்
<i>Transition period</i>	நிலைமாற்ற காலம்
<i>Urban Agglomeration</i>	ஒருங்கிணைந்த நகர்ப்புறம்
<i>Urban fringe</i>	நகர்ப்புற விளிம்பு
<i>ubiquitous resources</i>	எங்கும் நிறைந்த வளங்கள்
<i>Vacuum Tubes</i>	வெற்றிட குழாய்கள்

TAMIL NADU - POLITICAL



TRIGONOMETRY TABLE

A	SIN(A)	COS(A)	Tan(A)
0	0.0000	1.0000	0.0000
1	0.0175	0.9998	0.0175
2	0.0349	0.9994	0.0349
3	0.0523	0.9986	0.0524
4	0.0698	0.9976	0.0699
5	0.0872	0.9962	0.0875
6	0.1045	0.9945	0.1051
7	0.1219	0.9925	0.1228
8	0.1392	0.9903	0.1405
9	0.1564	0.9877	0.1584
10	0.1736	0.9848	0.1763
11	0.1908	0.9816	0.1944
12	0.2079	0.9781	0.2126
13	0.2250	0.9744	0.2309
14	0.2419	0.9703	0.2493
15	0.2588	0.9659	0.2679
16	0.2756	0.9613	0.2867
17	0.2924	0.9563	0.3057
18	0.3090	0.9511	0.3249
19	0.3256	0.9455	0.3443
20	0.3420	0.9397	0.3640
21	0.3584	0.9336	0.3839
22	0.3746	0.9272	0.4040
23	0.3907	0.9205	0.4245
24	0.4067	0.9135	0.4452
25	0.4226	0.9063	0.4663
26	0.4384	0.8988	0.4877
27	0.4540	0.8910	0.5095
28	0.4695	0.8829	0.5317
29	0.4848	0.8746	0.5543
30	0.5000	0.8660	0.5774
31	0.5150	0.8572	0.6009
32	0.5299	0.8480	0.6249
33	0.5446	0.8387	0.6494
34	0.5592	0.8290	0.6745
35	0.5736	0.8192	0.7002
36	0.5878	0.8090	0.7265
37	0.6018	0.7986	0.7536
38	0.6157	0.7880	0.7813
39	0.6293	0.7771	0.8098
40	0.6428	0.7660	0.8391
41	0.6561	0.7547	0.8693
42	0.6691	0.7431	0.9004
43	0.6820	0.7314	0.9325
44	0.6947	0.7193	0.9657
45	0.7071	0.7071	1.0000

A	SIN(A)	COS(A)	Tan(A)
45	0.7071	0.7071	1.0000
46	0.7193	0.6947	1.0355
47	0.7314	0.6820	1.0724
48	0.7431	0.6691	1.1106
49	0.7547	0.6561	1.1504
50	0.7660	0.6428	1.1918
51	0.7771	0.6293	1.2349
52	0.7880	0.6157	1.2799
53	0.7986	0.6018	1.3270
54	0.8090	0.5878	1.3764
55	0.8192	0.5736	1.4281
56	0.8290	0.5592	1.4826
57	0.8387	0.5446	1.5399
58	0.8480	0.5299	1.6003
59	0.8572	0.5150	1.6643
60	0.8660	0.5000	1.7321
61	0.8746	0.4848	1.8040
62	0.8829	0.4695	1.8807
63	0.8910	0.4540	1.9626
64	0.8988	0.4384	2.0503
65	0.9063	0.4226	2.1445
66	0.9135	0.4067	2.2460
67	0.9205	0.3907	2.3559
68	0.9272	0.3746	2.4751
69	0.9336	0.3584	2.6051
70	0.9397	0.3420	2.7475
71	0.9455	0.3256	2.9042
72	0.9511	0.3090	3.0777
73	0.9563	0.2924	3.2709
74	0.9613	0.2756	3.4874
75	0.9659	0.2588	3.7321
76	0.9703	0.2419	4.0108
77	0.9744	0.2250	4.3315
78	0.9781	0.2079	4.7046
79	0.9816	0.1908	5.1446
80	0.9848	0.1736	5.6713
81	0.9877	0.1564	6.3138
82	0.9903	0.1392	7.1154
83	0.9925	0.1219	8.1443
84	0.9945	0.1045	9.5144
85	0.9962	0.0872	11.4301
86	0.9976	0.0698	14.3007
87	0.9986	0.0523	19.0811
88	0.9994	0.0349	28.6363
89	0.9998	0.0175	57.2900
90	1.0000	0.0000	∞

Geography – Class XII

List of Authors and Reviewers

Domain Experts

Dr. Kumaraswamy.K. UGC BSR Emeritus Professor,
Department of Geography,
Bharathidasan University, Tiruchirapalli-620 024

J.Maria Anita Anandhi, Former Associate Professor,
Department of Geography,
Nirmala College for women, Coimbatore – 641 012.

V.Tamilarasan, Associate Professor,
Department of Geography,
Government Arts College (Autonomous), Karur -

P.Ravikumar, Assistant Professor,
Department of Geography,
Presidency College, Chennai-600 006.

Reviewers

N.Nanjundan, Former Associate professor,
Department of Geography,
Periyar E.V.R Collage, Trichirapalli. 620 023.

M.Subramanian, Former Selection Grade Lecturer,
Department of Geography,
Periyar E.V.R Collage, Trichirapalli – 620 023.

Content Readers

B.Vasudevan, Assistant Professor,
Department of Geography,
Presidency College (Autonomous) Chennai- 600 005.

Dr.P.Sujatha, Assistant Professor,
Department of Geography, Bharathi Women's College,
Chennai- 600 108.

Academic Co-ordinator

K.Gomathi Lecturer
District Institute of Education and Training,
Tirur, Tiruvallur District.

Content writers

R.Subramanian, P.G.Assistant.,
Geography, GHSS, Nandanam, Chennai – 600 035.

N.P.Nisha, P.G.Assistant., Geography,
CGHSS, Pulla Avenue, Shenoyanagar, Chennai – 600 030.

A.Nirmala, P.G.Assistant.,
Geography, Sarojini Varadhappan GHSS,
Poonammallee, Thiruvallur – 600 056.

G.Vijayakamakshi, P.G.Assistant.,
Geography, St.Paul's Girls HSS, Mayiladuthurai – 600 109.

R.P.Axilla Pream Rajini, P.G.Assistant.,
Geography, Northwick HSS, Chennai – 600 013.

P.Shanmugam, P.G.Assistant.,
Geography, GHSS, Kangayam, Tiruppur – 638 701.

P.Ponmani Vetri Chelvan, P.G.Assistant.,
Geography, GBHSS, Mecheri, Salem – 636 453.

K.Annamalai, Principal,
Suguna International School, Coimbatore – 641 012.

D.Saraswathi, P.G.Assistant,
Geography, PCKG Govt. Hr. Sec. School, Kodambakkam,
Chennai – 600 024.

ICT Co-ordinator

Ruby Packiam.P, B.T, Assistant,
PUMS, KK nagar, Thiruthani.

QR CODE Management Team

R. Jaganathan, SGT,
PUMS - Ganesapuram, Polur , Thiruvannamalai.

J.F. Paul Edwin Roy, B.T, Assistant,
PUMS -Rakkipatty, Salem.

A. Devi Jesintha, B.T, Assistant,
G.H.S, N.M. Kovil, Vellore.

Art and Design Team

Layout

Manikaraj Prabahar. M.A
Balasubramani.R
Prasanth.C
Santhiyavu Stephen.S

Illustrator/Image Editing

R. Muthukumar,

In-House

QC - Rajesh Thangappan
- Jerald Wilson

Co-ordination

Ramesh Munisamy

This book has been printed on 80 G.S.M.
Elegant Maplitho paper.

Printed by offset at: