



GOVERNMENT OF TAMIL NADU

HIGHER SECONDARY SECOND YEAR

VOCATIONAL EDUCATION

**TEXTILES AND
DRESS DESIGNING**

Theory & Practical

A Publication Under Free Textbook Programme of Government of Tamil Nadu

DEPARTMENT OF SCHOOL EDUCATION

Untouchability is Inhuman and a Crime

Government of Tamil Nadu

First Edition – 2019

Revised Edition – 2020, 2022

(Published under New Syllabus)

NOT FOR SALE

Content Creation



State Council of Educational
Research and Training

© SCERT 2019

Printing & Publishing



Tamil Nadu Textbook and
Educational Services Corporation

www.textbooksonline.tn.nic.in

PREFACE

One of the most creative courses, Textiles and Dress Designing is considered to be a very prosperous vocational education stream not only in India but abroad as well. Fashion designing is a much sought-after career. This is because of the fact that the textile and fashion industry has grown by leaps and bounds and that too within a decade. People with a creative mind and students who are interested in gaining more knowledge in apparel designing and making, choose textiles and dress designing subject, to gain knowledge on building skills and focus in terms of conceptualization, design sense and individual artistic expression in fashion designing.

This textbook is technically designed with suitable objectives to cater many people who strive to reach the top of textile and fashion industry. Fashion students can analyze recent fashion trends and learn about basic business and merchandising principles. The hands-on practice allows students to apply skills in interpreting and developing projects in the different areas of fashion, and add more value to their creativity.

The major concepts of textiles and designing encompassing of pattern making, sewing, history of garment designing, computer applications in fashion, clothing care, entrepreneurship development and advertisement are given special focus in this textbook. Fashion is a booming career and a stream where your creativity is recognized.

Readers of the subject are sure to find the book extremely useful, convenient and interesting as well. Further, simple language is used for easy reading and understanding. It has been presented in such a way that the reader can grasp easily. Another important feature of the book is that all the patterns are illustrated with diagrams and examples. In a nutshell the book will help the reader to gain knowledge and enhance oneself to become an entrepreneur or find a suitable job.

**Learning Objectives**

Learning objectives briefly describe the contents of the unit. It also outlines the knowledge gained by the students.



Interesting facts to motivate students to gain more information regarding the unit.

Infographics

Visual representations of the unit for better understanding.



To facilitate reading at anytime, anywhere.

Concept Figures

Conceptual diagrams that portrays the technique of drafting, sewing and application of elements and principles of design in dress designing

**HOW TO USE
THE BOOK****Case Study**

Brief note on successful students who have pioneers in the field.

Career Guidance

List of job opportunities on successful completion of course.

References

List of related books for further reading.

**Teacher
Activity**

Innovative techniques to be carried out by tutor to enhance teaching.

**Student
Activity**

Skill oriented activities based on the units for better understanding.

Evaluation

Assess students under the category of understanding, reproducing and application oriented.

Glossary

Explanation of significant terms.

Web links

Web links- Digital sources for enriching further knowledge.

Model Question Paper

A model question paper to help students to face examinations.

TEXTILES AND DRESS DESIGNING CAREER GUIDANCE



SEWING TEACHER



MERCHANDISER IN GARMENT INDUSTRY



CAD DESIGNER IN FASHION INDUSTRY



MANAGER IN DYEING & PRINTING UNIT



ENTREPRENEUR - TAILORING UNIT



SPINNING MILLS



SUPERVISOR IN READYMADE GARMENT INDUSTRY



CUTTING MASTER IN GARMENT INDUSTRY

CONTENTS

Textiles and Dress Designing

Unit No.	Chapter Title	Page No.	Month
1	Finishing	1-19	June
2	Dyeing	20-33	June
3	Printing	34-46	July
4	Family Clothing Budget and Wardrobe Planning	47-56	July
5	Selection of Clothing and Clothing Care	57-74	August
6	Designing of Clothing	75-99	August
7	Identification of Fabrics and Preliminary Stitches in Garment Construction	100-106	August
8	Laying the Pattern, Marking and Cutting	107-126	September
9	Fashion Accessory and Ornamentation- Belts, Bows, Smocking and Traditional Embroidery	127-150	October
10	Selection of Fabric for Construction of Garments	151-166	October
11	Home Made, Tailor Made and Readymade Garments	167-176	October
12	Apparel Merchandising	177-195	November
13	Entrepreneurship Development	196-213	November

14	Advertisement	214-222	November
15	Role of Computer in Garment Industry	223-233	December
	<i>Case Study</i>	234-240	
	<i>Model Question Paper</i>	241-243	
	<i>Reference Books</i>	244	
	<i>Textiles and Dress Designing – Practical</i>	245-277	



E-book



Assessment



TEXTILES AND DRESS DESIGNING

Theory



Finishing

CHAPTER

1



LEARNING OBJECTIVES

- To gain knowledge about the types of finishes suitable for different types of fabrics
- To understand the modifications in fabric properties after imparting finishes

1.1 Introduction

Every fabric needs to look appealing to the eyes and feel good when touched. This can be achieved through fabric finishing. It is a process of converting woven or knitted fabric into a more useable material. The main modification done by finishing is improving the look, performance or hand feel. It not only changes the fabric appearance but also provides aesthetic value, improves its softness, adds comfort and durability, provides safety and improves the performance of the fabric. Finishes can also be applied during yarn formation stage. Some of the uses of finishing are:

- To improve the appearance of the fabric like colour, pattern and shine
- To change the texture of the fabric by giving finishes like embossing and smoothening
- To improve the feel of the fabric by making it softer, crisper or firmer
- To improve the drape of the fabric by adding or removing weight to it
- To improve the wearing qualities of fabric like crease resistance, stain resistance, flammability and water proofing
- To modify the care requirements of the textile like easy wash, quicker drying time, colour fastness and less shrinkage

Different fabrics undergo different finishing techniques depending upon the nature of fabric, its physical and chemical properties and its intended use. Finishing operations differs according to the properties imparted to the textile material.

1.2 Classification of Finishes

Textile finishes can be classified in many ways. The two main groups of finishes are:



1.2.1 Functional Finish

This type of finish changes the internal performance of the fabric. These are given to improve the aesthetic purpose of a fabric. Thus functional finishes can be further divided into two groups :

1. Aesthetic Finish

It is given to enhance the fabric appearance and its draping ability. Some of the important aesthetic finishes are :

- Napping and scudding
- Mercerization
- Shearing
- Softening
- Stiffening

2. Performance Finish

It is given to enrich the fabric properties like strength and durability. Some of the important functional finishes are :

- Antimicrobial
- Moth proof
- Crease resistant
- Durable press
- Soil resistant
- Water repellent or water proof
- Shrink proofing
- Flame resistant

1.2.2 Quality Finish

These types of finishes improve the quality of the fabric based on the time line

or usage. They can be temporary, semi-permanent or permanent.

1. Temporary Finish

As the name suggest the temporary finish is not a stable finish and it disappears immediately after the first wash or first few washes. It includes finishes like :

- Starching or sizing
- Softening
- Embossing
- Calendaring

2. Semi-Permanent Finish

This finishing is durable than temporary finish and can withstand more than 10 to 15 washes. It includes finishes like:

- Schreiner calendaring
- Buckram finish

3. Permanent Finish

Permanent finishing does not disappear and remains unaffected through all the conditions of wear and washing treatments given to the fabric. It includes finishes like:

- Flame retardant
- Resin finish
- Sanforising
- Water proof or water repellent

1.3 Types of Finishes

Scouring and bleaching are done prior to other finishes, as they improve the property of raw fabric for further processing hence they are also grouped under finishing. Some of the common finishes are discussed below.

1.3.1 Scouring

Scouring is the process by which all natural and additive impurities such

as oil, wax, fat and dust are removed to produce hydrophilic and clean textile material. It is one of the vital processes of wet processing.

Objectives of Scouring

- To make the fabric highly hydrophilic
- To remove impurities such as oils, waxes, gum, husks as nearly as possible
- To increase the absorbency of fabric or textile materials without physical and chemical damage
- To produce a clean material by adding alkali
- To prepare the fabric for subsequent process
- To remove non-cellulosic substance in case of cotton

Scouring can be carried out by two methods:

Saponification

The vegetable oil like glycerides of fatty acids, are present in the raw fabric. These oils are immiscible with water and hence they are heated with a solution of sodium hydroxide in water making the oil split up into its constituents—fatty acid and glycerine. Glycerine is mixable with water easily and the fatty acids react with sodium hydroxide present in the solution forming its sodium salt i.e. soap which is also soluble in water. Thus oil is removed from the fabric.

Emulsification

The wax and non saponifiable oils present in the fabrics are removed by emulsification. As the waxes and oils are not mixable in water a normal washing soap is used as an emulsifying agent. The soap makes an emulsion of the waxes and non saponifiable oils in water and brings them out.

The changes that occur during scouring are as follows :

- Saponifiable oils and free fatty acids are converted into soaps
- Pectins and pectoses are converted into soluble salts of pectic acid
- Proteins are degraded to simple soluble amino acids or ammonia
- Mineral matters are mostly dissolved
- Non- saponifiable oils are emulsified by the soluble soaps generated from the saponifiable oils
- Additive stains are removed
- Residual sizing materials are broken down into soluble products

The chemicals used in scouring are:

1. Caustic soda - to neutralize acidic materials, to saponify glycerides (waxes and oils), to solubilise silicates.
2. Surfactants - to reduce surface tension and minimize interfacial tension.
3. Detergents - to emulsify oil, fats, waxes and remove oil -borne stains.
4. Chelating agent - to deactivate metal ions.
5. Sodium silicate - to penetrate and break down lignins
6. Soda ash - to maintain pH
7. Solvent - to assist emulsification by dissolving oily materials.

1.3.2 Bleaching

Bleach is a chemical that removes colour or whitens a fabric via oxidation or reduction method. Many types of bleach have strong bactericidal properties, and are used for disinfecting and sterilizing.

Bleaching is another important pre-treatment next to scouring, performed on cotton fibres. This treatment is given to decolourize the natural colouring matter present in the cotton fabrics and impart a pure white colour. It increases the ability of the textile materials for dyeing and printing by removing any traces of colour present in it. Normally oxidative bleaching action is performed in the industries on cotton fibre substrates. Though a number of bleaching agents are available in the chemical market, few bleaching agents are used extensively. Calcium hypochlorite (CaOCl), Sodium hypochlorite (NaOCl) and Hydrogen peroxide (H₂O₂) are the most frequently used bleaching agents in the conventional cotton processing units.

Hydrogen peroxide is considered a universal bleaching agent, as it is suitable for all sorts of textiles. It is stable at neutral and value is near neutral pH. The pH of hydrogen peroxide solution can be modified based on the suitability. Processing pH of cellulosic is between 9 and 11.5; proteins 2.5 to 6.0 and for synthetics it is near neutral acidic pH.

In order to bleach cotton, the pH of hydrogen peroxide solution is maintained at around 11. When alkali is added the stability of hydrogen peroxide is reduced and decomposed at a fast speed. To control the rapid decomposition a stabilizer is added to the solution. The ingredients added during peroxide bleaching are normally; hydrogen peroxide (bleaching agent, 1-3% owm), sodium hydroxide or carbonate (bleaching promoters, 0.25 to 1.0% owm), sodium silicate (buffer or stabilizers, 0.5 to 1.0% owm)

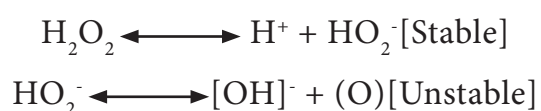

In the alkaline condition the instability of peroxide is continued by the concentration. The liberation of nascent oxygen is utilized for the oxidation reaction in a controlled manner by selecting the stabilizers to get uniform application.



Figure 1.1 Scouring Bleaching machine

1.3.3 Calendaring

It is a mechanical process that finishes the fabric, by passing it between sets of rollers and applying heat and pressure. The outside of the rollers can be smoother or engraved to give the perfect finish to the fabric, the structure of the rollers varies from hardened chromium plated steel to elastic thermoplastic rollers. By varying the rollers, adding any additional chemical treatment and temperature, a variety of calendared finishes can be produced like glazed or moiré fabrics.

Objectives

Calendaring is done for many purposes but the main objectives are:

- To give softening to the face side of the fabric
- To increase fabric lustre or glaze
- To give silk like appearance

- To close the open threads
- To decrease the air permeability
- To increase the fabric clarity
- To flatten the slubs
- To modify the fabric surface by embossing

DO YOU KNOW?

What do you mean by Moiré?

Moiré, is a textile material with a wavy (watered) appearance. It is produced mostly from silk, and sometimes from wool, cotton and rayon. The characteristic watery appearance is achieved by calendaring.



In general a calendaring machine has 2 to 7 rollers with most common being the 3 bowl rollers. Less number of bowls is used for lightweight fabrics whereas more numbers of bowls are used for calendaring heavy weight fabrics. The bowls are made with alternating hard steel and elastic. The elastic bowl is usually made from compressed paper or compressed cotton, however a lot of modern calendaring machines are made with Nylon 6 covering. This provision is given so that there remain resiliency between the two consecutive rollers and the compression remains uniform. Heating arrangements are made via steam circulation chamber.



Figure 1.2 Three Roll Calendaring Machine

The process parameters that can be controlled during calendaring are speed of the fabric, speed of the rollers and the surface of rollers. Different types of calendared effects are: surface glazing, ciré effect, moiré effect, Schreiner effect and embossing effect.

Different treatments are given to the fabric before calendaring. For example, to obtain a glazed finish like chintz (polished cotton), the fabric is first saturated in starch or wax or resin solution and is dried before calendaring. Starch or wax gives a temporary finish to the fabric but if the fabric is saturated in resin, it gives a durable glaze.

Calendared fabrics with their glossy or wet look are produced in the same manner as glazing. The fabrics are coated with a wax or resin before being calendared with heated rollers. When thermoplastic fibres are used, the fibre surface that comes in contact with the metal rollers melts and flattens slightly and produces a highly polished fabric. Examples of calendared fabric are taffeta, satin or tricot, silk or silk blend fabrics.



Moiré fabrics have characteristic water marked look that is produced during the calendaring process. The effect is developed using either a moiré embossing roller or by a high compression calendaring of two layers of ribbed-base fabric in a single pass. One popular method of preparing moiré fabric features using rollers that have been engraved with a design. The fabric is run between the engraved rollers with some sections of the fabric squeezed to reveal the finished design that has a watery look. This type of application is often used to create material styles that are ideal for evening gowns, clutch handbags, and other types of formal apparel and accessories for women.



Figure 1.3 Calendared Cotton Fabric

Schreiner finishes on fabrics produce soft lustre and hand by flattening the yarns and surface of a fabric through calendaring. The Schreiner calendar has a metal roller engraved with 200-300 fine diagonal lines per inch that are visible only under a magnifying glass. A Schreiner finish is used on cotton sateen and table damask to make them more lustrous and on nylon tricot to increase its cover.

Fabric embossing can also be carried out in the calendaring machine in which the fabrics can have a pattern imprinted or embossed into it. The embossed pattern is created by passing the fabric between a heated embossing roller and a shaped

paper roll. The degree of lustre given to the fabric can be modified by heating the chilled iron roll, by changing the pressure at the nip, by changing the speed of the machine, by carrying the moisture percent present in fabric. Various designs can be created by using a 2-bowl embossed roller or 3-bowl embossed roller arrangement.

1.3.4 Embossing

Embossing is a process that alters the surface of the fabric by providing a three dimensional or raised effect on selected areas. The embossing procedure requires the use of two dyes: one that is raised and one that is recessed. When the dyes are produced, a dyes maker engraves the desired design into several metal plates, which are the embossing dyes for use on an embossing machine. The engraved and the recessed dyes fit into each other so that when the fabric is pressed between them, the raised dye forces the fabric into the recessed dye and creates the embossed impression. A specific level of pressure is applied to the dye in order to squeeze the fibres, which results in a raised area. The embossed design is permanent if the fabric has a thermoplastic fibre content or if a resin is used or the fabric is heat set. Embossing is often used in combination with foil stamping.



Figure 1.4 Fabric Embossing Machine



1.3.5 Sizing or Starching

Size is one of the numerous substances that is applied to a yarn or fabric to act as a protective filler or glaze. In sizing or starching, the fabric is immersed in a mixture containing waxes, oils, glycerines and softeners to control the fabric body by adding stiffness and weight. If the sizing is resin based and heat set, it is permanent in nature but if the size is water soluble, it is removed during washing. Gelatin is used on rayon's because it is a clear substance that enhances the natural lustre of fibres.



Figure 1.5 Sizing Machine

In the weaving process the fabric warp has to undergo several types of actions like cyclic strain, flexing, abrasion at various loom parts and inter yarn friction. To reduce the breakage of yarns in the weaving process the warp yarns are sized before weaving which increases its strength, abrasion resistance and decreases the yarn hairiness. Different types of water soluble Polymers Vinyl Alcohol (PVA) called textile sizing agents or chemicals such as modified starch, Polyvinyl Carboxy Methyl Cellulose (CMC) and acrylates are used as sizing agents. In order to reduce the abrasiveness of the warp yarns wax is also added to the sizing liquor. The type of yarn material, the thickness

of the yarn, type of weaving machinery determines the sizing recipe. The sizing can be done by hand or sizing machine. After the weaving process gets over the fabric is desized to remove the sizing liquor.

1.3.6 Stiffening

Stiffening agents are applied to the cloth to increase the weight of the fabric, to improve its thickness and lustre. Depending on the end use of the fabric, some fabrics are needed to be made stiffer and crispier. But, the effect of these stiffening agents is temporary and once the fabric is washed, most of the finishes are removed. Stiffening agents such as starches which are used for finishing of cotton cloth are derived from potato, wheat or corn. Dextrin's are used for dyed and printed fabrics as they do not have any undue effect on the dye or print of the cloth. Natural gums are mainly used in printing as well as finishing process whereas modified cellulose like resins are used as stiffening agents.



Figure 1.6 Double Stiffened Buckram Fabric

Acid stiffening is mostly used for fine yarn cotton fabrics as it gives stiffness as well as transparency to the fabric. It involves rapid immersion in sulphuric acid, followed by immediate neutralization

by sodium hydroxide. The finish is permanent in nature and is also known as Organdi finish or Parchmentisation.

1.3.7 Softening

Softening of fabric is a very important functional finish which is required to give a pleasant hand feel to the fabric and impart better drapability. Fabrics that are harsher and stiffer because of their construction or due to some prior finishing process are softened by this method. Softening can be done by either mechanical or chemical process. Simple calendaring softens hand of the fabric, but is temporary in nature. Silicone compounds are mostly used as softeners which are durable and require curing. The different types of softeners are anionic softeners, cationic softeners, non-ionic softeners, reactive softeners, emulsion softener and silicon softeners. Other types include emulsified oils and waxes which often result in a semi-durable finish.



Figure 1.7 Fabric with Bad Drape at Left and Fabric with Good Drape at Right

Anionic softeners are not fast to wash. They are compatible with resin and used as a temporary finish with starch and cationic product.

Example: Sulphonated oils and fatty alcohol sulphates. Non-ionic softeners have excellent stability against yellowing and are not fast to dyeing. Cationic softeners

are substantive to cellulosic material and therefore, remain on cloth for few washes. They are compatible with resins. Reactive softeners are more durable softeners and react chemically with the ($-OH$) groups of cellulose. They are more expensive and also toxic in nature. Emulsion softeners are more popular because it reduces the loss of tear strength on resin finish and are fast to washing. Silicon softeners are the most used softeners in recent times. These are the manmade polymers based on the framework of alternate silicon and oxygen bonds with organic substituent are attached to silicone.

1.3.8 Shearing

Shearing is a process that evens out the length of the pile of a fabric in a controlled manner. It removes the surface fibres, yarn ends, knots and similar irregularities and surface flaws with the help of cropping or cutting. The fabric is passed through a series of tension bars and over an angled shearing bed which uses blades to cut the protruding fibres. The shearer head consists of spiral blade which is in contact with a ledger blade. The fabric is wound helically around a rotating cylinder which moves around spiral blade and ledger blade. Strong suction is used to remove the cut fibres from the machine.

The distance to move the bed of ledger blade is adjustable and the height of the pile can be regulated. Shearing may also create a smooth surface or a patterned or sculptured effect by flattening portions of the pile with an engraved roller and shearing off the areas that remain erect, and steaming the fabric to raise the flattened or taller portions. Thus Shearing can be used to create raised patterns or to smooth the overall nap of a fabric.

Some sheared fabrics are also brushed. Fabrics are brushed to remove loose fibres, and in some cases, to direct the nap of the surface in a single direction. Common examples of fabrics with brushed finishes are brushed corduroy, brushed denim and brushed flannel.



Figure 1.8 Industrial Fabric Shearing Machine

Do YOU KNOW? When was first Antimicrobial finish given on fabrics?

Evidences of fabric dipped in turmeric for the purpose of wound healing are identified during excavation of Indus Valley Civilization. This is the first evidence on antimicrobial finish.

Compounds like 8-hydroxyquinoline salts, copper naphthenate, copper ammonium fluoride and chlorinated phenols were used on cotton as fungicides in the World War II by the US army Quarter.



Antimicrobial finish

1.3.9 Singeing

Singeing is the removal of surface fibres by an intensive flame or by reflected heat. Singeing refers to burning off. It is an important pre-treatment process of the fabric and if not done properly results in unclear prints and patterns. It is often used with shearing to control surface fibres and particularly fibre blends. Singeing is more intensive than shearing as it penetrates deeper into the fabric than is possible by shearing, which is limited to the fabric surface.

Objectives

- To get a clear and smooth surface
- To obtain a soil less fabric
- To print patterns with higher clarity

At first the fabrics are brushed lightly to remove the undesirable fibres and then the fabric is passed over heated copper plates. The flames burns the fibre ends and the singeing area then enters a water bath. The water bath stops any singeing sparks and later the cloth is removed.



Figure 1.9 Gas Singeing Machine

1.3.10 Napping

It is a mechanical finish in which fibres are raised from the woven or knitted fabrics by rotating, bristled and wire covered brushes. The fabric brings out

raised fibres all through its surface. The examples of napped fabrics are cotton flannel, rayon flannel, woollen and worsted napped fabric like kersey and melton. Napped fabrics have softer handle, better insulation properties due to more air entrapment. These fabrics are mainly used as blankets and for winter clothing.



Figure 1.10 Napping Machine

1.3.11 Mercerization

It is a finishing treatment of cotton and/or natural fibres composed by cellulose with a strong caustic alkaline solution (300 g/l) in order to improve its appearance by making it lustrous. The finish was named after its discoverer, John Mercer (1791-1866). He invented a process in which cotton can be given a lustrous finish resembling silk which was named “mercerization”. The strong caustic soda on cellulosic material causes the fibres to swell and simultaneously there is a longitudinal shrinkage in the fibre. The morphological structure of the fibre gets modified giving it a shinier surface which is also resistant to wear and washing. Thus, we can say that mercerising results in the swelling of the cell wall of the cotton fibre which increases its surface area and reflectance and giving the fibre a softer feel.

DO YOU KNOW? Why is mercerization been done on textile fabrics?

It is done to impart a greater affinity for dyes and chemical finishes, to increase tensile strength and lustre

Types of Mercerization

There are two types of mercerization:

Tension Mercerization

- The purpose of tension mercerization is to increase lustre of Cotton fibres
- The fibre untwists and swells, lumen becomes rounder in cross-section and it gains lustre
- Dye affinity and chemical reactivity increase
- Fabric becomes stronger and smoother

Slack Mercerization

- Slack mercerization is not as lustrous as tension mercerization
- Improves elongation and recovery properties
- Used for producing comfort stretch garments and fabric bandages, which need to conform to body shapes.

Mercerisation alters the chemical structure of the cotton fibre. The structure of the fibre inter-converts from alpha-cellulose to a thermodynamically more favourable beta-cellulose polymorph.



Figure 1.11 Mercerizing Machine

Process

The mercerizing process involves these three steps:

Step 1: Impregnation of the material in relaxed state with cold caustic solution of required strength and wet-ability.

Step 2: Stretching while the material is still impregnated in the caustic solution.

Step 3: Washing off the caustic soda from the material while keeping the material still in the stretched state.

An optional last step in the process is passing the thread over an open flame; this incinerates stray fibres, improving the fabric's appearance. This is known as "gassing the thread" due to the gas burner that is typically used.

Mercerizing can take place directly on grey cloth, or can also be done after bleaching. It can be done with or without tension in both cold and hot conditions. In both cases the mercerised cotton has an increased affinity for both reactive and direct cotton dyes, water and an increased strength.

Advantages of Mercerization

- Larger dyeing affinity
- Larger dimensional stability of the articles

- Increasing of the lustre
- Increasing of the tensile strength
- Better covering of dead cotton
- Improving touch

1.3.12 Heat Setting

Heat setting is an important part in textile finishing. It is one of the functional finishes which are carried out mainly on synthetic fabrics. It eliminates the internal tensions generated during the manufacture of fibre and fixes the new state by rapidly cooling it. Heat setting fixes the fabrics in the relaxed state and thus avoids subsequent shrinkage or creasing of fabric. Presetting of goods make it possible to use higher temperature for setting without considering the sublimation properties of dyes and also has a favourable effect on dyeing behaviour and running properties of goods. On the other hand, post-setting can be combined with some other operations such as thermasol dyeing or optical brightening of polyester. Post-setting as a final finish is useful to achieve high dimensional stability, along with desired handle.



Figure 1.12 Heat Setting Machine

1.3.13 Water Proof Finish

Water proof finish gives the resistance of water to the fabric. To increase the resistance various substance like paraffin, acid, resin, tannin, drying oils, alum or alumina salt carbonate magnesia are applied on to the fabric. The number of times the coating is done varies depending upon the substance used. A water-proof fabric is completely moisture proofed. The fabric is coated or laminated with a film of natural or synthetic rubber or plastic, such as vinyl or polyurethane to give proofing effect. Water proof finishes adversely affect the comfort property of the fabric as they limit the passage of air and possesses a rather firm and a bad hand feel.



Figure 1.13 Water Proof Fabric

1.3.14 Water-Repellent Finish

Water repellent finishes are chemical finishes which resist the penetration of water into the fabric but permits the passage of moisture or air. When the fabric becomes very wet the water eventually passes through it. The yarns are coated with the repellent material like wax which permits the passage of air and vapour between the interlacing in the fabric. Water and the other liquid remain on the surface in small bead rather than spreading out and getting absorbed. The chemicals used are silicones, fluorocarbons,

paraffin's etc. Some chemicals used for water repellency are also stain repellent. The combination of fabric finish and structure is important to achieve water repellent finish because it depends on the surface tension and fabric penetrability. The combination can make fabric which is stain resistance, having soft feel and a good drape.

Water repellent finish can be of both durable and non-durable types. The non-durable repellents are easily removed in laundering or dry cleaning. They do not provide satisfactory resistance to oily liquids. Durable repellent finish can be either repellent to water or oil or both. Fluro-carbon compounds have excellent durability to both dry cleaning and laundering.

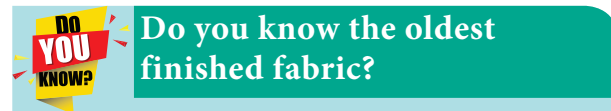

Fulling cloth is one of the oldest finished fabrics. It is seen in Scots hat woven fabric, done centuries ago using engraving to change.



1.3.15 Flame Retardant Finish

Flame retardant finishes is one of the varieties of functional finishes. They play an important role on textiles by providing safety and giving escape time from a potential hazard. When a fire starts flame,

retardants reduce the flame spread and rate of fire development by blocking the flames access to fuel and hindering future flame propagation. Boric acid/Borax, Di-ammonium Phosphate and Phosphoric acid, Sulfamic acid and Ammonium Sulfamate are a few substances used for non-durable flame retardant finishes. The durable flame retardant finishes include chemicals such as THPC- Tetakis Hydroxymethyl Phosphonium Chloride and its derivatives, N-Methyldimethyl Phosphonopropioamide, Phosphonic and Phosphoric Acid and its derivatives.



Figure 1.14 Flame Retardant Jacket

1.3.16 Anti-Microbial Finish

Antimicrobial finishes restrain the disease and decrease the risk of infection from following injury likes development of bacteria, other aroma causing germs, damage from perspiration and decay. These finishes are also called anti- bacteriostatic, germicidal or antiseptic finishes These finishes are mainly used for clothing that comes in close contact with the skin like shoe linings, hospital linings and carpeting. Wall covering and upholstery are also treated with antimicrobial chemicals. It is added to the spinning solutions in manufacturing fibres.

The most common chemical used for imparting anti-microbial finish is ziconium peroxide and sometimes an exposure to ethylene oxide gas is also used. Sutures, bandages and surgical gloves are treated with ethylene oxide because it is easy to available, low cost, safer and ultimate for medical products. The sterile environment to be maintained until the package is opened. Antimicrobial finish process includes gas treatment, chemical treatment and irradiation treatment.



Figure 1.15 Uses of Anti-Microbial Finished Fabrics

1.3.17 Antistatic Finish

Synthetic fibres of hydrophobic nature are prone to generation of static charges. This problem is very troublesome while processing the fabric at high speed in dry state. Static electricity is produced or created when two non-conducting surfaces such as synthetic textiles rub together. The two surfaces become oppositely charged and as the rubbing continues an electrical charge builds up. The wearer can experience the electric shocks and the fabric tends to cling to the body of the wearer. Antistatic finishes are chemical substances applied to reduce and eliminate static charge. The chemical substance used absorbs moisture from the atmosphere and thus reducing the

dryness of the fabric that causes the static charge build up. Anti-static effective chemicals are largely chemically inert and require thermosol or heat treatment for fixing. In general thermosolable anti-static agents also have a good soil release action which is as permanent as the anti-static effect. Anti-static finishes may also be of polyamide type being curable at moderate temperatures.

1.3.18 Moth Proof Finish

Moth proofing finish is a kind of functional finish given to textiles to prevent the growth of moths. Moths like silverfish attack fibres like cotton and wool. Fluorine compounds, naphthalene, DDT and paradichloro benzene are some of the chemicals used for imparting moth proof finishes to fabrics. They are available in crystal, cake and spray form. Cellulosic fibres are also treated with boric acid to prevent the rapid growth of mildew and fungus.



Figure 1.16 A Woollen Fabric Eaten by Moths

1.3.19 Shrink Proofing or Sanforising or Compacting

Controlled residual shrinkage is an important quality parameter for many fabrics. For example, excessive shrinkage is undesirable for fabrics to be made into

garments. Here, the residual shrinkage should be less than 2% otherwise the garment will not fit after it is laundered. Mechanical compacting is one method of reducing residual shrinkage. The process forces yarns closer together and the fabric becomes thicker and heavier. As a result of this, the net yardage yield is reduced. A sanforizer is a fabric compactor developed by Cluett Peabody. The term 'Sanforized', is their registered trademark and is used to market fabrics that meet certain shrinkage specifications. The term Sanforized is now generally accepted to mean a fabric that has low residual shrinkage. It is used to describe shrink proofing processes. The process, consists of a range where the fabric is first moistened with steam, to make it more pliable, run through a short tenter frame to straighten and smooth out wrinkles, through the compressive shrinkage head and then through a Palmer drying unit to set the fabric.

The key to any compactor is the head where force is applied to move parallel yarns closer together. More fabric must be fed in than is taken off. A Sanforizer uses a thick rubber blanket running against a steam heated cylinder as the compacting force. The thick rubber blanket first goes over a smaller diameter roll which stretches the convex surface of the blanket. Fabric is metered onto the stretched blanket and the fabric and blanket together come in contact with the steam heated cylinder. At this point, the stretched rubber surface contracts to its original length and then is forced to contract an additional amount as it forms the concave configuration of the heated drum. Since the fabric is not elastic, an extra length of fabric is thrust between the rubber

blanket and the heated cylinder. Friction between the rubber blanket and steel drum force adjacent yarns to move closer together until the unit length of fabric become equal to the unit length of rubber blanket it rests on. Heat is created by constantly stretching and relaxing the rubber blanket. The blanket is cooled by spraying water on it after the fabric exits from the unit.



Figure 1.17 Compacting / Sanforizing Machine

The degree of shrinkage can be controlled by the thickness of the blanket. The thicker the blanket, the greater is the stretched length at the bend. A longer length of fabric will be fed into the compactor causing the degree of compacting to be greater. To be effective, the degree of compacting needed should be predetermined ahead of time. This is done by characterizing the shrinking behaviour of the fabric by laundering. The degree of compacting should not exceed the degree of shrinking otherwise over compacting will cause the fabric to “grow” when relaxed.

1.3.20 Soil Release Finish

Textile materials are attracted to dirt or soil. Development of static charge electricity to hydrophobic textiles makes them prone to soiling. This is not readily removed during laundering and gets re-deposited on the

fabric. Also, the hydrophobic materials are not wetted properly during laundering which causes problem with staining.



Figure 1.18 Soiling of Fabrics

Soil release finish is one of the functional finishes which work by making the textile fibres more absorbent or hydrophilic. The hydrophilic finishes increase the wet ability of the fibre and facilitate soil release during washing. It also prevents soil re-deposition on the fabric. It also reduces the static charge on the cloth by maintaining moisture on the fabric surface which is mostly observed in polyester fabrics. They also improve the antistatic properties, fabric drapability and comfort.

1.3.21 Wrinkle Resistant or Crease Resistant Finish

The ability of the fabric to resist the formation of crease or wrinkle when slightly squeezed is known as ‘crease resistance’ of the fabric. The ability of a fabric to recover from a definite degree from creasing is called crease recovery. Finishes to reduce the undue wrinkles on fabric or garments is called as wrinkle resistance finish. Cotton, rayon and flax are more susceptible to wrinkles due to the hydrogen bonds of the cellulosic molecules in their amorphous region. Due to application of heat or moisture, the hydrogen bond breaks and new

hydrogen bond occurs at new dimensions. Therefore wrinkling can be reduced if the hydrogen bond formation is less. Resins such as Formaldehyde, DMU (Di-methylol urea), DMEU (Di-methylol ethylene urea), DMDHEU (Di-methylol di-hydroxyl ethyleneurea), and Modified DMDHEU (Di-methylol di-hydroxyethylene urea) are mainly used for imparting wrinkle resistance finish to a fabric.



Figure 1.19 Fabric with Crease Resistant Finish

POINTS TO REMEMBER

- Scouring and Bleaching are done prior to other finishes, as they improve the property of raw fabric for further processing.
- The wax and non saponifiable oils present in fabrics are removed by emulsification.
- Bleach is a chemical that removes colour or whitens a fabric via oxidation or reduction method.
- Bleaching treatment is given to decolourize the natural colouring matter present in the cotton fabrics and impart a pure white colour.
- Calendaring is a mechanical process that finishes the fabric by passing them between a series of rollers and applying heat and pressure.
- Calendered fabrics with their glossy or wet look are produced in the same manner as glazing.
- Embossing is a process that alters the surface of the fabric by providing a three dimensional or raised effect on selected areas.
- Stiffening agents are applied to the cloth to increase the weight of the fabric, to improve its thickness and its lustre.

ACTIVITIES FOR TEACHER

- To show different types of finishes
- To arrange a factory visit to finishing units

ACTIVITIES FOR STUDENTS

- Prepare an assignment regarding various types of finishes
- To ask the students to do a finishing process on the sample given to them.



INTERNET RESOURCES

https://www.youtube.com/watch?v=7ljwYeN7kbw	Knit Fabric Shrinkage/ Dyeing and Finishing Parameters
https://www.youtube.com/watch?v=X07XXMllnhc	Textiles: Industrial Finishing Processes

GLOSSARY

Embossing	Alters the surface of the fabric by providing a three dimensional or raised effect on selected areas
Shearing	A process that evens out the length of the pile of a fabric
Singeing	Removal of surface fibres by an intensive flame or by reflected heat
Mercerization	A finishing process to increase lustre of Cotton fibres
Heat setting	One of the functional finishes which is carried out mainly on synthetic fabrics.
Water proof finishes	A finish which gives the resistance of water to the fabric
Moth proof finishes	A finish to prevent the growth of moths

QUESTIONS AND ANSWERS

PART – I Objective Questions



- To produce a smooth surface finish on fabrics _____ process is done
 - Starching
 - Singeing
 - Embossing
 - Heat Setting
- The term _____ is used to describe shrink proofing processes.
 - Sanforizing
 - Singeing
 - Calendaring
 - Napping
- The most common chemical used for imparting anti-microbial finish is _____.
 - Gelatin
 - Ziconium Peroxide
 - Thermasol
 - Polyurethane

4. In mercerization the fabric is treated with _____ solution.
- Formaldehyde
 - Sulphur
 - Paraffin
 - Caustic Soda
5. _____ finish burns any fibre end projecting from the surface of the fabrics.
- Flame Retardant
 - Anti Static
 - Singing
 - Mercerizing
6. Saponification is a process involved in _____
- Bleaching
 - Scouring
 - Compacting
 - Calendaring
7. John Mercer discovered _____
- Sanforizing
 - Bleaching
 - Emulsification
 - Mercerization
8. _____ fabrics have characteristic water marked look that is produced during the calendaring process.
- Moiré
 - Ciré
 - Schreiner
 - Embossed
9. _____ process is used for adding stiffness and weight to the fabric.
- Singeing
 - Scouring
 - Sizing
 - Sanforizing
10. Shearing is a process that evens out the length of the pile of a fabric by _____
- Burning
 - Cutting
 - Rubbing
 - Brushing

PART – II

Answer in Three (Or) Four Points

- What is the need for finishing fabrics?
- Give the types of quality finishes.
- Define calendaring.
- Briefly explain sanforizing.
- What is shearing?
- What are the objectives of singeing?
- Briefly describe mercerization?
- Why is softening finish given to a fabric?
- What is scouring?
- What are the uses of anti static finishes?

PART – III

Answer in a Paragraph

- Explain the different types of effects achieved during calendaring.
- What is starching and why is it used?
- Give the advantages of mercerization.
- Explain bleaching by hydrogen peroxide.
- Name the chemicals used in bleaching?
- Give the difference between water proof and water retardant finish.

7. Explain moiré fabrics.
8. Name some chemicals used in giving flame retardant finish.
9. Describe compacting.
10. What are the types of scouring?

PART – IV

Answer in One Page

1. What are water proofing finishes? Briefly explain types of water proofing finishes.
2. Explain Flame retardant finishes.
3. Elucidate the process of mercerization?
4. Explain the changes that occur in the fabric after scouring.
5. Explain the different types of calendared fabrics.

Answers for Objective Questions

- | | | | | |
|--------|--------|--------|--------|---------|
| 1. (b) | 2. (a) | 3. (b) | 4. (d) | 5. (c) |
| 6. (b) | 7. (d) | 8. (a) | 9. (c) | 10. (b) |

CHAPTER

2

Dyeing



LEARNING OBJECTIVES

- To understand the classification of dyes
- To get an insight into the applicability of individual dyes
- To learn about the different stages of dyeing

2.1 Introduction

Man has known colour since his creation. Nature has been like **Art** with an inexhaustible colour palette with beautiful compositions that inspire man to capture colour on cloths that adorn his body. Primitive man coloured the caves and smeared his body with pigments that he discovered. Ancient people extracted dye from roots, stems, leaves, fruits, berries, flowers, nuts, vegetables, minerals, animals and insects.

Colour plays a vital role in **Human** life. Nature's colour changes with changing season. The colourful wall paintings of Ajanta during the first century AD (CE) and description of natural dyes in

Atharvaveda provides evidence for the use of dyes in ancient period. People liked to colour everything they use, especially clothes. So they extracted colour from different natural sources such as plants, animals, insects and minerals and applied it on to fabric. The quest for new colours led to the discovery of synthetic dyes which later on became a full-fledged industry.

2.2 Classification of Dyes

Dyes are organic compounds with two components namely Chromophore, which imparts colour and Auxochrome that help in substantivity of dyes. They are classified into natural dyes and synthetic dyes.

2.2.1 Natural Dyes

Natural dyes are colour substances obtained from natural sources. Natural dyes are used for all types of textile dyeing and printing until the middle of nineteenth century. The use of natural dyes were reduced due to the advent of synthetic dyes, though they were economical and possess excellent fastness properties. However, the growing consumer awareness on the harmful impact

of synthetic dyes, concern for environment worldwide and stringent environmental laws lead to the revival of natural dyes.

2.2.1.1 Advantages of Natural Dyes

- Natural dyes are extracted from natural sources and hence they are eco-friendly
- Produces soft and soothing colours
- These dyes provide excellent protection from UV rays
- Natural dyes like turmeric have anti-microbial properties and hence protect the fabrics and wearers from microbial attack
- Some natural dyes possess mosquito repellent and flame resistant property
- They can be obtained from the natural sources which are abundant in a particular area. Hence supply of raw materials will be continuous and transport charges will be lower

2.2.1.2 Disadvantages of Natural Dyes

- Natural dyes are difficult to store
- Dye extraction is a time consuming process
- Reproducibility of the same colour shade is difficult
- Impurities in natural dyes fades away the colour produced
- Availability of these dyes depends on the seasons
- Natural dyeing process is difficult to standardize











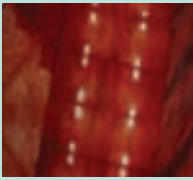

Classification of Natural Dyes

Natural dyes are classified in to three types based on the source of origin namely vegetable dyes, animal dyes and mineral dyes.

2.2.2 Vegetable Dyes

The earliest dyes were of vegetable origin, discovered by accidentally staining garments with juices of fruits or plants. Vegetable dyes are obtained from different parts of plants such as leaves, flowers, fruits, pods, bark etc. These vegetable dyes can be applied directly or with different mordants.

- **Indigo:** Indigo (blue dye) is called as the king of all natural dyestuffs. It imparts blue colour. It is extracted from the leaves of the leguminous plant, *Indigofera tinctoria*. It is suitable for dyeing cotton and wool.
- **Indian Madder:** It produces shades of red on textile fabrics. It is used for dyeing cotton and woollen fabrics. It is extracted from roots of *Rubia tinctoria*.
- **Turmeric:** It produces shades of yellow on fabrics. It is suitable for dyeing cotton, silk and wool. The yellow dye is extracted from the ground root (rhizome) of turmeric plant (*Curcuma longa*).
- **Marigold:** It is extracted from lemon or orange coloured marigold (*Calendula officinalis*) flower. It is suitable for dyeing both silk and wool fibres.
- **Henna:** The dye is extracted from the dried leaves of Henna plant, *Lawsonia inermis*. It produces yellowish orange colour. It is suitable for dyeing wool and silk fibres.
- **Tea:** Leaves of tea plants (*Camellia sinensis*) or tea powder is used to extract dye. It produces different shades of brown.
- **Onion:** The dye is extracted from the outer most skin or peel of the onion (*Allium cepa*). The onion skins if properly dried can be used for one year.

Name of the Plant	Parts used	Dyed fabric
Indigo		
Indian madder		
Turmeric		
Marigold		
Henna		
Tea		
Onion		

DO YOU KNOW? Who is Adolf Von Baeyer ?

Adolf Von Baeyer is a German chemist, who was awarded the Nobel Price in Chemistry in 1905 for discovering the molecular structure of Indigo and developing a process to produce it synthetically.



Adolf Von Baeyer

2.2.3 Animal Dyes

Dyes extracted from certain insects and invertebrates are called as animal dyes. Various shades of red and purple were obtained from animal origin. Cochineal, Tyrian purple and Lac are the commonly used animal dyes.

1. Cochineal

Cochineal dye is extracted from the dried bodies of the female red bug (*Dactylopius coccus*). It produces crimson and scarlet colours with mordants aluminium and tin oxide. This dyestuff was mostly used for dyeing wool and silk. These dyes exhibit excellent fastness properties.

2. Tyrian Purple

This dye is extracted from the sea snails found in Mediterranean Sea. The amount of dye produced was very limited and therefore very expensive. Hence, it is called Royal purple.

3. Lac Dye

This dye is extracted from the fluid secreted by the lac insect (*Lacifer lacca*), which lives on the twigs of the banyan trees and other varieties.

It produces crimson and scarlet colours. These dyes possess good fastness to light and washing.

Animal dyes are also obtained from murex snail (purple colour) and Octopus/ Cuttle fish (Sepia brown).

DO YOU KNOW?

How invention of colour changed the world?

William Henry Perkin, in 1856 during his experimentation with coal tar to synthesize an artificial quinine as a cure for malaria invented the first synthetic dyestuff called “Mauve” which revolutionized the world in both dye making and fashion.

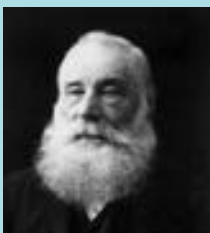

William Henry Perkin

DO YOU KNOW?

What is Tyrian purple dye?

Tyrian purple is a natural dye obtained from shellfish. Approximately 8500 shellfish is used to produce one gram of purple dye. Hence the dye was more worth than its weight in gold.



2.2.4 Mineral Dyes

Dyes extracted from mineral sources are called as mineral dyes. Most widely used mineral dyes are Iron, which produces yellowish brown shades, chrome yellow, prussian blue and manganese brown. The dyes obtained from mineral sources may be poisonous and hence are not being used commercially.

Table 2.2 Animal Dyes

Source Name	Insect	Dyed fabric
Cochineal		
Tyrian purple	 	
Lac dye		

Table 2.3 Mineral Dyes

Source name	Dye	Dyed fabric
Iron		
Prussian blue		
Chrome yellow		
Manganese brown		

2.2.5 Synthetic Dyes

Dyes that are produced chemically are called as synthetic dyes. These are classified based on the chemical composition of the dye.

2.2.5.1 Direct Dyes

When a dye colours the fabric directly without the help of any fixing agent, the dye is said to be a direct dye. Direct dyes are water soluble. They are easy to produce, simple to apply and cheap in cost of production and application. Direct dyes are anionic in nature and have greater affinity for cellulosic fibres. They are used to dye cellulose fibres without a mordant in bright shades and they produce a wide range of colours. A levelling agent such as sodium carbonate is added for even dyeing. At the end of dyeing, exhaustion agent such as salt (NaCl) is added which helps the dye to leave the liquor and get attached to the fibre. Some direct dyes are used to dye wool, silk and nylon. Direct dyes can be applied to wide variety of textile materials such as apparel, upholstery fabrics, draperies, linings and automotive fabrics. Most direct dyes have good fastness to light but poor wash fastness.

2.2.5.2 Reactive Dyes

Dyes that react with the fibres and form covalent bonds are called as reactive dyes. They become an integral part of the fibre. They are water soluble and are used to dye cellulose, protein and polyamide fibres. They produce full range of bright shade across the spectrum. They exhibit excellent wash fastness and good light fastness properties. Dyeing of fibre with reactive dyes involves 3 steps, namely exhaustion of dye (NaCl or Glauber's salt),

fixation of dye (sodium carbonate or sodium hydroxide) and washing off.

2.2.5.3 Basic Dyes

Basic dyes have cationic or basic groups (positively charged) and hence they are also known as cationic dyes. Basic dyes react with the acidic groups present in the fibres and form electrovalent bonds. Basic dyes are soluble in alcohol but not easily soluble in water. Basic dyes exhibit brilliant shades of colour which is not shown by other dye classes. Basic dyes are suitable for dyeing wool, silk and acrylic, but they have no affinity towards cellulosic fabrics. Basic dyes are used along with a mordant for fibres such as cotton, linen, acetate, nylon and polyester. Basic dyes show moderate light and wash fastness. For dye preparation, the dyestuff is mixed with equal amount of acetic acid followed by warm water under constant stirring.

2.2.5.4 Acid Dyes

Water soluble dyes that require acid (sulphuric, acetic, formic acid etc.) in dye bath to dye silk or wool are called as acid dyes. These acid dyes are mostly sodium salts of organic acids. When dissolved in water, acid dyes produce negative ions (anions or acidic groups) which react with positive ions of protein fibres and get attached to the fibre through electrovalent bonds. Acid dyes are similar to direct dyes however they cannot be applied to cellulosic fibre due to slight variations in structure. Acid dyes have greater affinity for protein and polyamide fibres. They possess very good fastness to washing and good fastness to light. A large colour range is available with acid dyes. They are inexpensive.

2.2.5.5 Mordant or Chrome Dyes

Natural dyes and some synthetic dyes do not have affinity towards fibres. With the help of some chemicals, they can be used to dye fibres. These chemicals are called mordants or mordant dyes. Mordant dyes have affinity for both fibre and dye and form a linkage between the dye molecule and the fibre.

2.2.5.6 Disperse Dyes

Disperse dyes are insoluble in water. Their solubility is increased by increasing temperature and by adding dispersing agents. They are suitable for dyeing hydrophobic fibres like nylon, polyester, acrylic and other synthetic fibres. Disperse dyes are non-ionic or neutral in nature. They have an excellent fastness to washing and sunlight exposure.

2.2.5.7 Vat Dyes

These dyes were initially fermented in a large wooden vessel known as vats and hence the name “vat dyes”. They are insoluble in water but soluble in alkali. Vat dyes are accepted into the fibre in a reduced or vatted form. When it is re-oxidized, it is then fixed to the fibre firmly. The dyes are treated with a reducing agent that converts them into leuco compounds, which is soluble in alkalis. The process of making the dyes soluble is known as Vatting. The leuco compounds are either colourless or exhibit a colour that is different from the colour of final product, which is achieved after oxidation. Once the dye is attached to the fibre, it gets oxidised and changed into an insoluble colour product that gets trapped inside the fibre. Indigo, an example of vat dyes has been used in India for long periods.

In the soluble form, vat dyes have excellent affinity for cellulosic fibres. Vat dyes are the fastest dyes for cotton, linen and rayon. They may be also applied to wool, nylon, polyester and acrylics with the use of a mordant. Vat dyes are resistant to light, acids and alkalies.

The basic principles of vat dye application can be summarized as follows:

- Conversion of the insoluble vat dye into the soluble leuco form by reduction or “vatting”.
- Absorption of the soluble reduced dye by the fibres
- Conversion of the absorbed dye back to the insoluble state by oxidation
- After treatment of the dye or printed material in a hot detergent bath to produce the true and stable shade with maximum fastness

2.2.5.8 Sulphur Dyes

Presence of sulphur is the characteristic feature of sulphur dyes. Like vat dyes, sulphur dyes are water insoluble and made soluble by the addition of reducing agents and alkali as solubiliser. They are converted into soluble leuco compounds by using sodium sulphide or sodium hydrosulphite as reducing agent. The leuco compounds have high affinity for cellulosic fibres. After dyeing the fabric, the dye is converted into insoluble form by the addition of potassium dichromate and acetic acid. Sulphur dyes do not produce brighter shades. They are cheap and produce colours like navy blue, black, khaki and olive green. They are used for black more than any other colours. They have excellent wash fastness property. The fabric loses its softness after dyeing with sulphur dyes.

2.2.5.9 Azoic Dyes or Naphthol Dyes

Unlike other colouring matters, the azoic dyes are not prepared as dye stuffs but have to be produced directly in the fibre by the combination of their constituents. The first component, naphthol in presence of sodium hydroxide give colourless or faintly yellow or brown colour when applied on cotton at room temperature. The naphtholated fabric when immersed in the second bath containing the second component base along with the acid and sodium nitrite at ice cold temperature produces bright colour which is insoluble in water. The two components form azo group during coupling. So the dye is known as **azoic dye**. Since it is formed inside the fibre, it is called **ingrain dye**. Azo dyes are also called as **ice colours** since their application involves use of ice to lower the temperature. They are widely used on cellulosic fibres and have limited application on acrylic, nylon and polyester. Azo dyes exhibit bright colours. They have good colour fastness to washing and light.

2.2.5.10 Pigment Dyes

Pigments are not true dyes because they have no affinity for the fibre. They are applied and held to the fabric with the help of adhesives and resins. Pigments are commonly used in dope dyeing and printing. Use of pigments saves both time and cost. Vat dye is called as dye when applied on fabric in solubilized form and is termed as pigment when applied on fabric in insoluble form using a binder. Pigment dyes exhibit excellent light fastness.

2.2.5.11 Optical Brighteners

These dyes are also called as colourless dyes or fluorescent whiteners. These dyes

absorb light at UV-region and emit blue light in visible region. It may be applied during bleaching or with the final finish. These dyes have affinity for cotton but are also used for wool, nylon, acetate and acrylics.

2.3 Dyeing Methods

The art of dyeing dates back to pre-historic times. It is practised from ancient time and it is as old as human civilization. Dyeing is the process of imparting colour to the fibre/yarn or fabric by the application of dyes or pigments. Colour is produced between the dye molecule and the fibre or fabric. The bond between dye molecule and fibre may be strong or weak depending on the dye used. Dyeing enhances the aesthetic look of the fabric. It is one of the surface ornamentation methods.

2.3.1 Stages of Dyeing

Dyeing can be done at any stage of textile production process such as at fibre stage, yarn stage, fabric or finished product.

Table 2.4 Stages of Textile Dyeing

Stage	Method of dyeing
Fibre	Stock dyeing
Wool sliver	Top dyeing
Manmade	Dope dyeing
Yarn	Skein dyeing, Package dyeing, Warp-beam dyeing, Space dyeing
Fabric	Beam dyeing, Beck/Winch dyeing, Jig dyeing, Jet dyeing, Pad dyeing
Finished product	Product dyeing
Blended fabrics	Union dyeing, Cross dyeing

2.3.1.1 Dyeing at Fibre Stage

The process of dyeing at fibre stage is called as fibre dyeing. It includes stock dyeing, top dyeing and dope dyeing.

Stock Dyeing

Fibres are dyed by the process of stock dyeing. In this method, dyeing is carried out in a large enclosed vessel called kiers. Fibres are placed loosely in perforated containers and kept inside the kiers. The dye liquor is circulated through the fibres at high temperature until the desired colour is obtained. Excess dye solution is removed after dyeing process. The dyed fibres are washed and dried.



Figure 2.1 Stock Dyeing

Advantages

- Produces varied colour effects by blending different coloured fibres
- Large quantities of fibres can be dyed at one time
- Produces uniform colour
- Colour fastness ranges from good to excellent
- Dye easily penetrates the fibres and hence crocking is prevented.

Disadvantages

- Expensive and time consuming
- Fibre wastage if not consumed immediately

- Dyed fibres loses its flexibility and hence not readily spin as undyed fibre
- Cannot withstand rapid changes in fashion

Top Dyeing

Wool that has been combed to remove short fibres is called as **top**. Top is wound on perforated spools and dye solution is passed through it. Top dyeing method results in even dyeing.



Figure 2.2 Top Dyeing

Advantages

- Uniform dye uptake
- Dye penetrates into the fibre therefore good colour fastness

Disadvantages

- Flexibility is reduced
- Time consuming

Dope dyeing

Manmade fibres such as polyester and polypropylene are dyed by this method. In this method, dye is mixed with the spinning solution before the filament is extruded through the spinneret.



Figure 2.3 Dope Dyeing

Advantages

- Dyeing is uniform
- Dyed textiles have good to excellent colour fastness to washing and light

Disadvantages

- The strength of solution dyed filaments are slightly lesser
- Expensive method

2.3.1.2 Dyeing at Yarn Stage

The process of dyeing at yarn stage is called as yarn dyeing. Yarn dyeing is preferred to create interesting checks, stripes and plaids in the fabrics. Yarn dyed fabrics are deeper and richer in colour. Fabric with dyed warp and undyed weft are example for chambrays. This includes techniques like skein dyeing, package dyeing, warp-beam dyeing and space dyeing.



Figure 2.4 Yarn Dyeing

Skein Dyeing

In this method, the yarns are loosely wound in hanks or skein form. The hanks

or skeins are hung on perforated rods and immersed in a dye bath. The dye solution is circulated in and out of the yarn to achieve an even shade. This method is commonly used for dyeing acrylic and wool yarns.

Advantages

- Loose arrangement of yarn permits excellent dye penetration
- Yarns retain softer feel

Disadvantage

- Most expensive yarn dyeing method

Package Dyeing

Yarns are wound on cones, spools or similar units. These yarn packages are arranged on perforated rods in a rack and immersed in a tank. The dye solution is forced outside from the rods and forced back to the centre under pressure through the packages so that, the dye penetrates the entire yarn.

Advantages

- Dyeing capacity is higher (550 kg) when compared to skein dyeing (200 kg)
- Material to liquor ratio is less
- Uniform dyeing

Disadvantages

- Package dyed yarns do not retain softness and loftiness feel
- Not suitable for high twist yarns which will not allow dye to penetrate

Warp-Beam Dyeing

This method is similar to package dyeing. In warp-beam dyeing, the yarn is wound onto a perforated warp beam and placed in a tank containing dye solution. Dyeing is

carried out under pressure for deeper and uniform penetration of dye. This method is used for the manufacturing of denims, in which warp yarns are dyed with indigo and weft yarns are left undyed.

Advantage

- Economical than other yarn dyeing methods

Disadvantage

- May not produce high fashion fabric since warp yarn will be dyed in specific colour

Space Dyeing

In this method yarn is not completely dyed, but it is dyed at intervals. Space dyeing is done by two methods namely, Knit-de-knit method and OPI space -dye applicator method. In knit-de-knit method, the knitted fabric is dyed and de-knitted, which results in appearance of alternating dyed and un-dyed spaces. In OPI space-dye applicator method, the yarns are allowed to pass through space dye baths at very high speed which results in intermittent dyeing.

Advantages

- Produces brighter and deeper shades.
- Create interesting checks, stripes and plaids.

Disadvantages

- Costly and time consuming
- May not create designs to match current fashion

2.3.1.3 Dyeing at Fabric Stage

The process of dyeing woven or knitted fabric is called as **piece dyeing**. Piece dyeing methods include beam dyeing, beck or winch dyeing, jig dyeing, jet dyeing and pad dyeing.

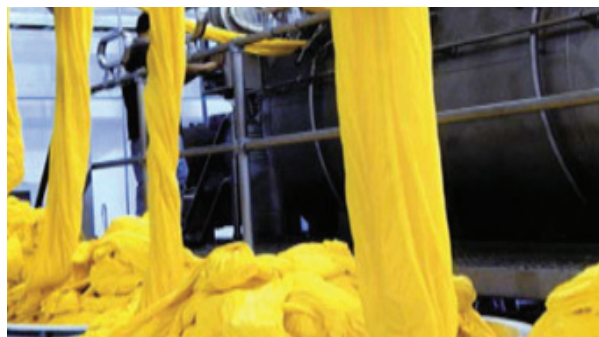

Figure 2.5 Piece Dyeing

Advantages

- Uniform dyeing
- Inexpensive than fibre or yarn dyeing
- Versatile and flexible in accommodating changing fashion trends.
- Faster and easier

Disadvantage

- The ends of the fabric does not have some colour as the remaining fabric

Beam Dyeing

This process is similar to warp-beam dyeing of yarns. In this method, the woven or knitted fabrics are wound on perforated beams and immersed in dye solution. Dye is circulated through the fabric

Beck / Winch Dyeing

This method is done to dye the fabrics of longer length. The fabric is circulated through the dye bath in tensionless rope form. The ends of the fabric are tied together to form a loop. The fabric moves over a rail onto a winch reel which immerses it into the dye bath and draws the fabric up. The process is repeated till the fabric is dyed uniformly and to the desired colour shade. About 1000 m or 900 kgs of fabric can be dyed at a time. The dyed fabrics retain its original softness feel. This method is widely used for woolen woven and knitted fabrics.



Jig Dyeing

In this method, the fabric is held on rollers at full width and passed through the dye bath. The fabric is let off from one roller into the dye bath and wound on to the other roller. After one cycle, the process is reversed and the fabric is let off from the second roller to the first. The process is repeated till the desired colour strength is achieved. About 250 kg of fabric can be dyed at a time. This method is preferred for heat-sensitive thermoplastic fabrics that cannot be dyed in rope form as they will form permanent crease or colour streaks in the fabric. This method is not suitable for knitted or stretch fabrics which should not be subjected to tension and also to fabrics where a soft feel is required.

Jet Dyeing

In this method the fabric is dyed in a rope form. It is placed in a heated tube or column where jets of dye solution are thrown on the fabric at high pressure. The fabric also moves along the tube. The dye solution is circulated faster than the fabric while colouring it thoroughly. About 500 kg of fabrics can be jet-dyed at a time. This method of dyeing is suitable for both woven and knitted fabrics made up of wool, cotton, viscose rayon, polyester and its blends.

Pad Dyeing

In pad dyeing, the fabric at full width is passed through a trough containing dye bath. The fabric is then passed between two heavy rollers which force the dye to penetrate in to the fabric and squeeze out the excess dye solution. For the dye to set, the fabric is passed through a heat chamber. Then the dyed fabric is rinsed and dried.

2.3.1.4 Dyeing at Product Stage

This is the last stage of dyeing. When the finished product such as garment is dyed, it is called as product dyeing or garment dyeing. The fabric undergoes pre-treatments such as desizing, bleaching and mercerization before dyeing. The most widely used method for garment dyeing is paddle dyeing. In this method, garments are packed loosely in net bags. Ten to fifty of such bags are kept in large tubs containing dye solution. The dye is agitated by a motor driven paddle which increases the penetration of dye. Garment dyeing is suitable for products such as sweaters, T-shirts, casual clothing and hosiery.

Advantages

- Economical
- No shade variations

Disadvantages

- Colour bleeding and fading.
- Not suitable for products with zippers, sewing, threads, lining etc.

2.3.2 Dyeing of Blended Fabrics

When a fabric is made of one type of fibre/yarn, dyeing process is simple but when it is composed of more than one kind of yarn as in a blend, dyeing process is complex. Special procedures are carried out where different dyes that are suitable for each fibre need to be selected.

2.3.2.1 Union Dyeing

In this method, blended fabrics are dyed to the same shade to get a solid-coloured fabric. Fabrics can be dyed by one or two bath process. In one bath process, dyes appropriate for each fibre is added in same dye bath. In two bath process, dyes are added separately to each fibre subsequent to one another.



2.3.2.2 Cross Dyeing

In this method, fabrics are dyed in such a way that different fibres produce different shades with the same colour. Sometimes, one of the fibre components is left undyed. Cross dyeing results in checks, plaids, striped and multi-coloured fabrics. Cross dyed fabrics are similar to fibre or yarn dyed textile materials. If one of the yarns of the fabric is vegetable fibre and the other is from animal fibre, then the fabric is dyed in two separate baths, suitable for each fibre. This produces colourful effects.

2.4 SUMMARY

Dye is a chemical compound that produces colour when applied on the

fabric. Dyes are classified in to natural and synthetic dyes based on their source of origin. Synthetic dyes are further classified based on their application conditions and affinity towards certain fibres namely direct dyes, reactive dyes, basic dyes, acid dyes, mordant dyes, disperse dyes, vat dyes, sulphur dyes, azo dyes, pigment dyes and optical brighteners. Dyeing is the process of imparting colour to fibres, yarns or fabrics using dyes. Dyeing involves the transfer of colour from the dye bath to fibre surface and diffusion from the surface into the fibre. Dyeing can be done at different stages of textile manufacturing process such as fibre, yarn, fabric or finished product stages.

POINTS TO REMEMBER

- Dyes are organic compounds that are used to impart colour to fibre / yarn or fabric
- Dyes are classified into natural and synthetic dyes
- Dyeing is the process of imparting colour to fibres, yarns or fabrics using dyes
- Dyeing can be carried out at different stages of textile manufacturing processes such as fibre, yarn, fabric or finished product
- Blended fabric can be dyed by union dyeing and cross dyeing

ACTIVITIES FOR TEACHER

- To show different types of dyes.
- To arrange for field visit to dyeing units.

ACTIVITIES FOR STUDENTS

- To motivate students to collect different natural dye sources
- To ask students to dye a fabric using any one synthetic dye



INTERNET RESOURCES

https://www.youtube.com/watch?v=ThPhBpsRHQo	Garment dyeing process
https://www.youtube.com/watch?v=ILoZophnHfs	Natural dyeing
https://www.youtube.com/watch?v=UEMcyjyoOY	Indigo dye extraction

GLOSSARY

Stock dyeing	Dyeing at the fibre stage
Dope dyeing	Dyeing of man-made fibres by adding the dye to the spinning solution
Piece dyeing	Dyeing at the fabric stage.
Chromophore	A part of a dye molecule that is responsible for the production of colour with the substrate.
Pigments	Coloured insoluble substances that don't have affinity towards fibre
Levelling agents	Enhances even distribution of dye throughout the fibre.
Mordants	Compounds that link dye molecule and the fibre by reacting with both of them.
Reactive dyes	Dyes that form covalent bonds with the fibre.
Leuco Compounds	Colourless compounds which are produced when vat dyes are subjected to reduction reaction.
Colourfastness	Resistance of a textile material to change in colour.
Exhaustion Agents	Compounds that enhances the absorption of dye molecule by the textile substrate.

QUESTIONS AND ANSWERS

PART – I

Objective Questions

- Skein dyeing is done at
 - Yarn stage
 - Fibre stage
 - Fabric stage
 - Garment stage
- Which of the following dye is called as 'ice colours'?
 - Direct dyes
 - Reactive dyes
 - Azoic dyes
 - Sulphur dyes
- Dyeing of wool fibre is called as
 - Dope dyeing
 - Top dyeing
 - Skein dyeing
 - Package dyeing
- The dye that forms covalent bond with the fibre is
 - Reactive dye
 - Sulphur dye
 - Direct dye
 - Acid dye



5. Which of the following dye is used to produce black colour?
- Direct dye
 - Acid dye
 - Basic dye
 - Sulphur dye

PART – II

Answer in Three (Or) Four Points

- List the stage of dyeing.
- What are natural dyes?
- Write the basic principles of vat dyeing.
- Define union dyeing.
- What are optical brighteners?

PART – III

Answer in a Paragraph

- How are natural dyes classified?
- Explain the various method of yarn dyeing.
- Differentiate union dyeing and cross dyeing.
- Write a note on direct dyes.
- Discuss the properties of sulphur and vat dyes.

PART – IV

Answer in One Page

- Explain in detail about the classification of synthetic dyes.
- Describe the different methods of fabric dyeing.
- Elaborate on the various methods of fibre dyeing.

Answers For Objective Questions

1. (a) 2. (c) 3. (b) 4. (a) 5. (d)

CHAPTER

3

Printing



LEARNING OBJECTIVES

- To understand the styles of printing
- To get an insight into different printing methods
- To be familiar with the after treatment processes for printed fabrics

3.1 Introduction

The art of printing fabric was known as early as 300 BC (BCE) Printing is the art of colouring the surface of any item. Tattooing of body is one of the most common printing of olden days. The impression of object dipped in dyes on fabric is the basic technique of printing. Textile printing is defined as the 'localized dyeing' or restricted form of dyeing a particular area of cloth or design. Dyes or pigments are applied to produce attractive patterns or designs with one or more colours. Printing is quicker and cheaper method of colouring fabrics. Generally a pigment or paste is needed to print textiles. Printing is carried by different methods namely block, screen, stencil etc.

3.2 Printing Paste

In printing, dyes or pigments are applied in the gel form to prevent the flowing of print design during printing and subsequent drying. Dyes are thickened by mixing it with gums or starches. This thickened dye solution is called as print paste. Print paste is composed of dyestuff, thickener, hygroscopic agents and auxiliary chemicals. Thickeners are added to improve the viscosity and better penetration of the dyestuff into the fabric. The thickener used for print paste preparation may be natural like starch, gum Arabic or synthetic polymers like polyvinyl alcohol and polyacrylamide. Hygroscopic agents used for print paste preparation are water soluble substances like urea and glycerine. They help the dye to enter into the fibre structure for fixation. Auxilliary chemicals such as solvents improve dye solubility and colour yield. Additional chemicals may be added depending on the fibres and dyes. For example, citric acid may be added for acid dyes or alkali added for reactive dyes. Thickness and freshness of the printing paste are two important aspects to be considered for the quality and durability of printing.

3.3 Difference Between Dyeing And Printing

Dyeing	Printing
The process of imparting colour to the fabric is called dyeing.	Pigments or dyes applied locally or discontinuously to produce different designs on the fabric is known as printing.
It is performed on fabric, yarn or fibre in wet condition.	It is performed on fabric in dry condition.
Half bleaching is enough for fabric preparation.	Full-bleaching with optical whitener is essential.
Dyeing can be done on fibre, yarn and fabric.	Printing is done on fabrics only.
Colour is applied in the form of solution.	Colour is applied in form of thick paste.
For dyeing there is no design.	For printing there is a specific design.
Dyes are applied on both the sides of the fabric.	Dyes are applied on single side of the fabric.
Only one colour is generally used for dyeing	One or more colours are used in printing process.
In dyeing process, colour penetrates through the fibre or fabric.	Colour is applied only on the surface.
A particular temperature is maintained in the dyeing process.	Carried out at room temperature.
Thickener is not used.	Thickener must be used.
The density of dye solution is low.	The density of dye solution is high.
Generally after dyeing, steaming, and curing are not required.	After printing, steaming and curing is must for fixing the dye to the fabric.
Dyed fabrics are soft to touch.	Printed fabrics are harsh to touch.
Water consumption is high.	Water consumption is low.
Huge time is required for dye application.	Less time is required for printing process.
Liquor ratio is high.	Liquor ratio is less.

3.4 Styles Of Printing

Fabrics can be printed in three different styles namely direct, discharge and resist styles.

3.4.1 Direct Style of Printing

The most common style of printing textile fabric is direct printing. In this method the dye is directly applied onto the fabric. Dyes are used in paste form. It is the simplest and oldest style of printing. It can be done on a



white fabric or coloured fabric. The dye is imprinted on the fabric in paste form and any desired pattern may be produced. Dark colour prints in lighter background is the characteristic feature of direct style printing. In this style of printing, the printing paste is transferred to the selected areas of the fabric and the pigments adhere to the fabric surface. Direct style of printing is used in block printing, screen printing or roller printing methods.

- easiest style of printing
- economical
- This style is easy, economical and suitable for printing both simple and complicated designs.

3.4.2 Discharge Style of Printing

In this method, the fabric is printed on a dyed fabric. The printing paste used in this method contains a discharging agent, which will bleach or destroy the colour from the dyed fabric in the printed areas. The resulting white area is brighten the overall design. Sometimes the base colour is removed and another colour is printed in its place. The discharging agent is an oxidizing or reducing agent capable of discharging colours by oxidation and reduction. Potassium chlorate or sodium chlorate (oxidizing agents) and stannous chloride (reducing agent) are commonly used discharging agents. The effects produced are very striking as the white area obtained brightens the overall design. This style of printing enabled intricate and fine designs to be printed on the fabric. If the fabric is not thoroughly washed after printing, the strength of the fabric may be affected due to the use of discharging agents. The advantages of discharge style of printing produces light, bright colour on a dark background, printing is sharp and fine and easier to work. However

the major disadvantages of this method is the cost involved.

3.4.3 The Resist Style

In this method, the bleached fabric is first printed with a substance like wax, rice paste, china clay or chemicals such as acids, alkalis and salts that resist dye penetration and fixation. The printed fabric is then dipped in cold dye bath, so that the resisting agent remains unaffected and only the areas free of the resist agent are coloured. After dyeing process, the resist paste is removed, leaving white or light coloured patterns on a dark background. Batik, tie and dye are examples of resist printing. The durability of the fabric is not affected by the resist method.



Ancient Printing of Fabric

The earliest type of printing on fabric is block printing also called relief printing. This is the process of dye being pressed onto a fabric from a carved material; historically wood, copper but also rubber and now many other materials. Then in the 18th Century the technique of roller or cylinder printing came about, this is the process by which the fabric is carried along a rotating central cylinder and pressed by a series of rollers, each of which is engraved with the design. Each roller is fed a different colour through feed rollers, and some roller printing machines were even able to print 6 colours at once, making them much faster than the block printing process.



3.5 Methods of Printing

3.5.1 Block Printing

Block printing is the ancient method of printing designs on the textile material by hand. It is the simplest of the printing methods. In this method, the desired design is carved on a wooden or metal block. The fabric is pinned on a table which is firm, strong and withstands the pressure of printing. The top is made of metal with a resilient surface made of artificial leather. The wooden block is stamped in the print paste or applied on the surface of the block. The block is stamped firmly on the selected part of the fabric. This process is repeated to print the required length of fabric. Multicoloured designs require separate blocks for each colour. Block printing is done mainly in decorative pieces or in expensive linens for upholstery purposes.



Figure 3.1 Block Printing Blocks

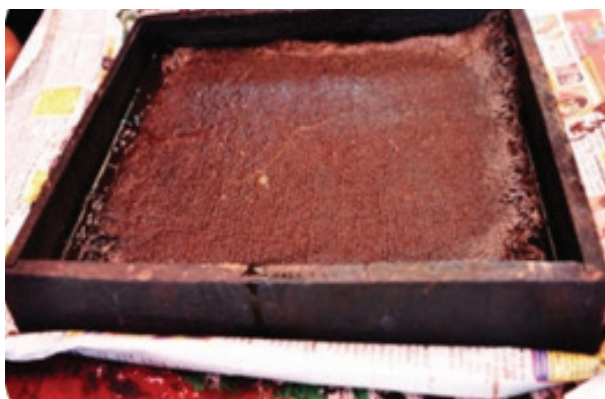

Figure 3.2 Printing Paste

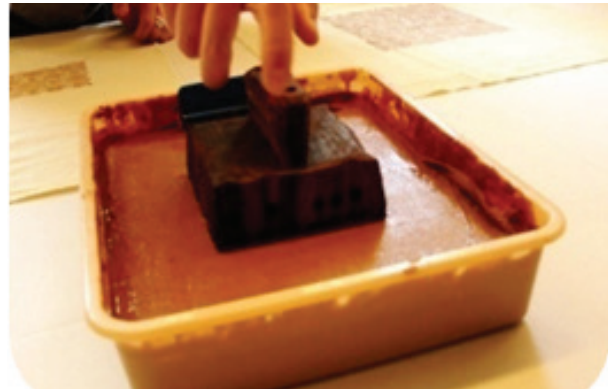

Figure 3.3 Application of Colour to the Block



Figure 3.4 Block Printing



Figure 3.5 Block Printed Fabric

Advantages

- Simplest method of printing
- Handmade art
- No special printing equipment required

Disadvantages

- Tedious and time consuming process
- Expensive
- Irregular colour shade
- Overall production is low
- Carving of blocks is difficult and laborious.

3.5.2 Roller Printing

It is a machine printing method, in which designs are printed on textile fabric by engraved rollers. This method of printing produces over 4000 yards of printed fabric per hour. The cylinder is made up of cast iron which acts as a printing table. The cylinder is covered with many layers of special fabric which has linen in warp and wool in weft for providing resiliency. It is covered with a layer of woollen blanket which provides the perfect surface for printing. The woollen blanket is covered with unbleached cotton cloth which will absorb excess dye. The last layer is the fabric which is to be printed.

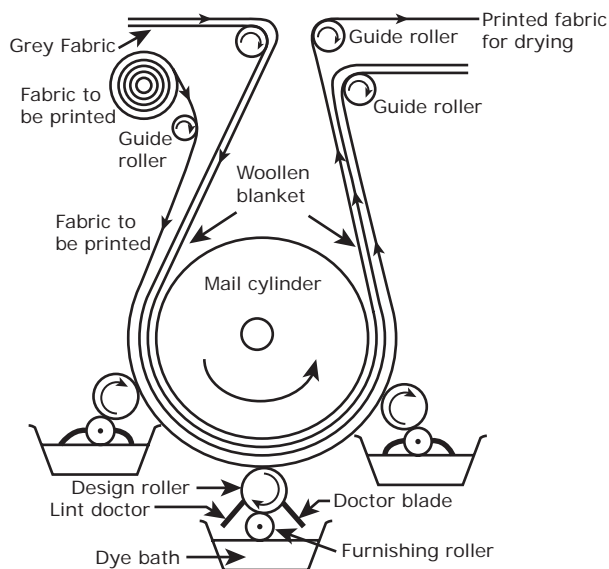

Figure 3.6 Schematic Diagram for Roller Printing

The design is transferred onto the cloth by engraved copper rollers. The design roller is arranged in such a way that the paste is applied on the roller and then transferred to the cloth. Number of engraved rollers rotate in contact with larger cylinder in rotation. The cloth is printed at the rate of 1000 to 4000 yards per hour. There are series of rollers

each imprinting a different colour on the fabric. The sizes of the engraved cylinders depend on the pattern to be printed. There are different ways of engraving the roller such as hand engraving, machine or mill engraving and photographic engraving. The design roller rotates against the cloth and the design is imprinted. The fabric moves on to the second roller where the second colour is printed. The doctor blade placed in contact with design roller scrapes the excess dye from the surface of the design roller. The printed cloth is dried and then steamed to set the dye.



Figure 3.7 Engraved Rollers



Figure 3.8 Roller Printed Fabric

Advantages

- Superior to other methods for the production of fine and precise designs
- Production is faster and accurate



- All colours required to print can be achieved in one process itself
- Versatile in colours, pattern and scale



Disadvantages

- Required skilled labour
- Laborious process
- Production cost is more for printing in small quantities
- Creation of engraved rollers is expensive
- Time consuming process
- If rollers are not aligned properly, it results in one or more colours falling out of position

3.5.3 Stencil Printing

In stencil printing, the design is first traced on the cardboard, wood, metal or plastic sheets with marker pens or pencils. Using scissors, knife or sharp blade the design is cut out. The uncut portion represents the part that is to be left uncoloured. When cutting the stencil care must be taken that small patterns must be cut through first. If large patterns are cut over or keeping small pattern inside then the smaller designs would be cut away with it. The stencil is placed on the fabric to be printed and the printing paste is applied with stencil brush through its interstices. When printing is repeated, care must be taken that the stencil on face side does not take up dye. Other colours can be applied on the design when the first colour dries. This method is suitable for both fine delicate design and large space design.



Figure 3.9. Preparing Stencil



Figure 3.10. Stencil Printing



Figure 3.11 Stencil Printed Bag

Advantages

- Low budget investment
- Exclusive designs and intricacy

Disadvantage

- Unevenness on printing table leads to uneven printing

3.5.4 Screen Printing

In this printing method, fabric is spread on large table and design screen is placed on the fabric. The screen consists of wooden frame covered with nylon or silk cloth and the technique is called as silk screen printing. Lacquer is applied on the screen to make the areas except design opaque so that printing paste is transferred through the design only. Based on the number of colours, many numbers of screens are prepared to complete the design. The printed portion should be allowed to dry before placing the second screen. When screens are placed properly, they will produce a complete design.



Figure 3.12 Printing Paste



Figure 3.13 Squeegee

Advantages

- Whole width of fabric is printed at once and so the process is faster than block printing
- Screens can be preserved for future use

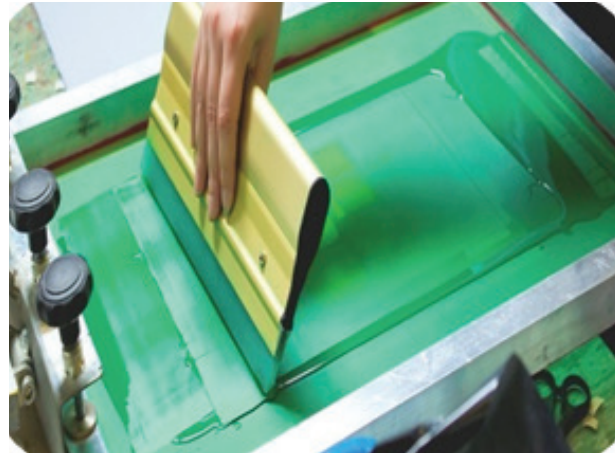

Figure 3.14 Printing the Fabric

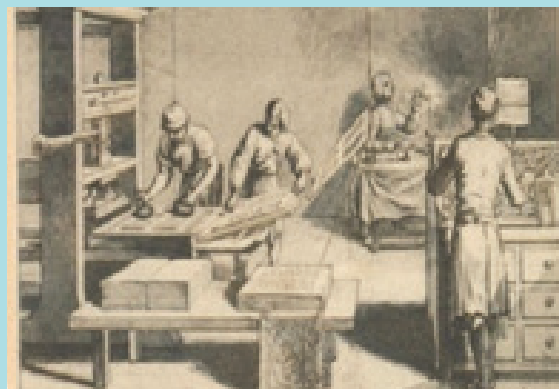

Figure 3.15 Screen Printed Fabric



When was First screen printing carried out?

It was first seen in China during Sung Dynasty (960–1279 AD (CE)). Further was adapted by other Asian countries like Japan, Western Europe, Asia until 18th century. The traditional process was called screen printing or silkscreen printing because silk was used in the process and the technique was referred as serigraphy or serigraph printing.





Disadvantages

- Preparation of screen is a time consuming process
- Preservation of screen needs extra care
- A small damage in the screen will spoil the entire printing

The design is created by painting or making non-design portions of the screen opaque, thus preventing the print paste from passing through. The areas where the print paste passes through will create a printed pattern. The screen is placed in contact with the fabric to be printed and the print paste is forced through the screen by a squeegee. The squeegee is used to spread the dye evenly through the screen. It is moved across the screen, forcing the print paste through the mesh openings. It helps in making a clean image on the printed surface. A screen is prepared for each colour of the design. There are two types of screen printing namely Flat screen printing and Rotary screen printing.

Flat Screen Printing or Hand Screen Printing

It is done by hand. The design is copied onto a series of very fine, flat screens, one for each colour to be printed. Lacquer or other impermeable substance is applied to all parts of the screen that are not part of its design. Each screen is fitted onto a wooden or metal frame. The fabric to be printed is spread onto a long table. A screen is set over the fabric and the printing paste is poured on the screen and forced through its unblocked areas onto the fabric with a squeegee. The screen is then moved to the next section of the fabric and the operation is repeated until the entire fabric is printed. This process is repeated for each colour of

the design. Hand screen printing is time-consuming and limited to short length of fabrics.

Automatic Flat Screen Printing

In this method, the process is automated and therefore faster. Here the fabric moves on a wide rubberized belt. The screens are placed above the belt. As the fabric moves, the screens are automatically lowered to the cloth and the appropriate colour is applied with automatically regulated squeegees. The cloth is dried in an oven.

Advantages

- Prints upto twenty colours in one run
- High production rate
- Produce brighter and cleaner shades
- Produces designs consisting of squares, circles and ovals

Disadvantage

- High cost

Rotary Screen Printing

This method of printing is done using machine. The fabric to be printed is moved on a wide rubber belt under the rotary screen cylinders. It is the fastest method of screen printing, with a production of more than 3500 yards per hour. A squeegee in each rotary screen forces the paste through the screen onto the fabric. The cloth is then passed into a drying oven to set the colour and washed.

Advantages

- Faster method of printing
- Rotary metal screens are light weight in contrast to the heavy copper rollers and hence they cost less.



- Operates continuously
- Production output is higher

3.5.5 Transfer Printing

Transfer printing means shifting of a design from one surface to another. In this method, designs made of pigments in paraffin or thermoplastic base can be transferred by heat and pressure to the fabric surface. The fabrics printed by this method become stiff and they are not fast to washing and light. A more effective and easier method of transferring the design intact from paper to fabric is by vaporizing the pigments in the design. Vaporizing can be done by dry heat transfer and wet heat transfer.

Disperse dyes are the only dyes which can be sublimated and used for heat transfer printing. Hence transfer printing is suitable for fabrics which have affinity to disperse dyes. Polyester, nylon and acrylics can be printed by this method. The fabric to be printed is passed through a heat transfer printing machine which brings paper and fabric together and passes them through the machine at about 204°C. Under high temperature, the dye on the printed paper sublimates and is transferred onto the fabric.



Figure 3.16 Transfer Printing

Advantages

- Production cost is low because there is no requirement of post printing treatments

- There is no wastage of pigment as the design made on paper is transferred to fabric
- Prints with excellent line details, intricacy and shading can be done
- Design can be made with many colours
- Rich and brilliant shades can be generated on woven and knitted fabrics
- Process is simple and does not require skilled labour
- High quality prints
- Less time
- Environment friendly process
- Economical for short runs

Disadvantages

- Selection of dyes is limited
- Poor colourfastness
- Not suitable for all types of fabrics

3.5.6 Batik Printing

Batik printing is a hand printing method. This is a resist style of printing. In this method, designs are made using wax and the fabric is immersed in the dye bath to colour the unwaxed portions. The wax is applied using various tools such as brushes, tjap and tjanting.

Tjanting is a spouted tool used to draw designs on the fabric with melted wax. Tjap is a pattern made of fine copper strips. The tjap is pressed on liquid wax and applied to the fabric. Wax is applied on both sides of the fabrics. After application of wax, the fabric is dyed to obtain desired colour. Only the portions not covered by the wax will absorb the dye. After the dye has been fixed, the fabric is dried, then boiled and rinsed to remove the wax. It is a slow process.



Figure 3.17 Nail Block in Wax for Batik Printing



Figure 3.18 Batik Printed Fabric

Advantage

- Gives an artistic effect to the fabric

Disadvantages

- Very laborious and time consuming process
- Dye has to be applied at a temperature lower than the melting point of wax

3.5.7 Photo Printing

In this method, the fabric is coated with a chemical that is sensitive to light and photographs are printed on the fabric. The results are similar to the photograph printed on the paper. This is a direct style of printing.



Figure 3.19 Photo Printing

3.6 After Treatment Processes of Printed Fabrics

After printing, the fabrics are dried to retain the printed design. It is an essential step to avoid staining of unprinted areas. It prevents bleeding of print paste from the design areas. Drying is followed by steaming which transfer the pigment from print paste to the fabric.

3.6.1 Steaming

In ageing or steaming process, the dyes and chemicals present superficially on the surface of the fabric is transferred into the fabric. The dried printed fabric has pigments or dyes, thickeners such as starch, gum etc. and printing auxiliaries on its surface. Steaming enhances the absorption of dyes or pigments on the fabric. In steaming or ageing, the dried printed fabric is exposed to steam at atmospheric or higher pressure for different time intervals. Steaming can be carried out continuously or batch-wise. When the printed fabric enters the steam chamber, steam condenses to form water





molecules which are absorbed by the thickener present in the printed fabric. The water absorbed by the thickener dissolves the dyes or pigments and hence increases the rate of absorption of pigment from thickeners to the fabric. As soon as steaming is done the fabric has to be dried.

3.6.2 Washing Off

The printed fabric after undergoing steaming process contains exhausted thickeners and some printing auxiliaries. If the thickeners used are temporary thickeners, they are removed by washing. Washing is done using cold water. Fabrics are washed with neutral soaps to avoid bleed in water. Rinsing removes the print paste chemicals and unfixed dye molecules. For vat dyed printed fabric, oxidation is carried out first followed by soaping.

Advantages

- Defines the print or design
- Prevents loss of colour
- Avoids spreading of colour beyond the design boundary

Disadvantages

- Expensive process because it requires steam and floor space
- Chances of spoiling the printed fabric due to power cuts etc.

3.7 SUMMARY

Printing is an aesthetic enhancement on fabric. There are various styles of printing namely direct, discharge and resist. In direct style of printing, the dye is directly applied onto the fabric. In discharge style, the fabric is printed on a dyed fabric. In the resist style, the bleached fabric is printed with a substance like wax, rice paste, china clay or chemicals such as acids, alkalis and salts. Different methods of printing include block, screen, stencil, transfer, batik, photo printing etc. Block printing is the ancient method of printing designs using wooden blocks. Roller printing is a machine printing, which produces over 4000 yards of fabric per hour. Stencil printing is done with the help of cardboard, wood, metal or plastic sheets with marker pens or pencils. Transfer printing refers to shifting of a design from one surface to the other. Batik printing is a hand printing method in which designs are made using wax. In Photo printing, the fabric is coated with a chemical sensitive to light and photographs are printed on fabrics to produce designs. The printed fabrics undergo after treatment processes such as drying, steaming and washing to enhance dye fixation and remove the unfixed dyes and chemicals.



POINTS TO REMEMBER

- Textile printing is called as localized dyeing. Dyes are imprinted on the fabric in paste form and desired design is produced.
- Different styles of printing are direct, discharge and resist printing.
- In direct printing, the printing paste is directly applied onto the fabric.
- In discharge printing, the fabric is first dyed and the colour is then removed by a chemical, whereas in resist printing, a resist paste is first printed and the fabric is then dyed.
- In block printing, wooden blocks are used to print the fabric.
- In roller printing, engraved copper rollers are used.
- Designs are transferred from paper to fabric, in transfer printing.
- Steaming is done to fix the dye permanently on to the fabric.

ACTIVITIES FOR TEACHER

- To demonstrate different printing methods.
- To arrange for field visit to printing units.

ACTIVITIES FOR STUDENTS

- To ask students to print a fabric using any one of the printing method.
- To prepare their own wooden block.



INTERNET RESOURCES

https://youtu.be/iQBtuDAY5WQ	Introduction to textile printing
https://youtu.be/spbyJdq0lZw	Methods of printing
https://youtu.be/2PO3AEpGL0E	Styles of printing

A-Z GLOSSARY

Thickeners	Thickeners are substances that improve the viscosity and consistency of the printing paste.
Steaming	It is a process done after printing to enhance dye penetration and fixation
Sublimation	It is the direct transition of solids to gaseous state without intermediate liquid state.
Engraving	Engraving is the carving of designs onto copper rollers.
Squeegee	It is a printing tool with wooden handle and flat, smooth rubber blade that spreads the print paste evenly across the stencil or screen.
Tjap	Design or pattern made of fine copper strips.
Tjanting	Used to draw pattern on the fabric with melted wax

QUESTIONS AND ANSWERS

PART – I

Objective Questions

1. Textile printing is defined as _____
 a) Semi dyeing
 b) Localized dyeing
 c) Complete dyeing
 d) Partial dyeing
2. The fabric is printed on a dyed fabric in _____ Style.
 a) Direct
 b) Resist
 c) Discharge
 d) Batik
3. The dye suitable for transfer printing is _____
 a) Direct dye
 b) Reactive dye
 c) Disperse dye
 d) Vat dye
4. Shifting of design from one surface of the fabric to another surface is made in _____ printing.
 a) Batik b) Screen
 c) Rotary d) Transfer
5. After treatment process in printing is done to _____ the prints.
 a) Retain b) Resist
 c) Disperse d) Wash-off



PART – II

Answer in Three (Or) Four Points

1. Define printing.
2. Differentiate discharge and resist style of printing.
3. What are the ingredients of the printing paste?
4. Mention the importance of thickener in a print paste.
5. State the importance of after treatment process in printing.

PART – III

Answer in a Paragraph

1. What are the advantages and disadvantages of block printing?
2. Explain the different styles of printing.
3. Give an account on stencil printing.
4. Explain the process of transfer printing.
5. Describe the after-treatment processes carried out on printed fabrics.

PART – IV

Answer in One Page

1. Explain the process of roller printing with diagram.
2. Describe flat screen printing and rotary screen printing.
3. Detail on batik printing.

Answers For Objective Questions

1. (b) 2. (c) 3. (c) 4. (d) 5. (a)

Family Clothing Budget and Wardrobe Planning

CHAPTER

4



LEARNING OBJECTIVES

- To understand the basic concepts of clothing budget
- To acquire knowledge for classifying clothes used by individuals
- To gain knowledge about wardrobe planning

4.1 INTRODUCTION

Clothes are an outward expression of how people feel about themselves and the world around them. Clothes act as a media which communicate about a person even before the voice is heard. Right clothes are necessary for health, poise and self-respect. The way the people dress and adorn themselves provide fascinating insight into human history revealing personality, wealth, religion, social status, occupation and nationality.

4.2 IMPORTANCE OF FAMILY CLOTHING

Clothes make an important major category in the family budget. Clothing is not only

a major category of expenditure but is also an important means of personal happiness and social identification.

To derive maximum satisfaction, one must develop good clothing practices. Good clothing practice includes the knowledge of wise selection of clothing, possession of an adequate wardrobe suited to various occasions which in turn helps proper dressing habit.

Selection of clothes is not an easy process in today's world. Clothing selection is influenced by aesthetic, psychological, sociological and economic factors. The selection of clothes is a personal decision based on fashion, lifestyle, income, sex and age.

Clothing purchases are an expense over which families need to look in for certain qualities while buying.

4.3 Classification of Clothing

Clothing used in day to day life is classified as :

- The fixed
- The modish

The fixed are substantially permanent and are not subject to fashion

changes but vary with each locality, example: basic clothing like inner wear. The modish type predominates in the western countries and changes rapidly in point of time over all parts of the world, which are subject to fashion changes, example: party wear dresses.

4.4 Types of Family

The first contact for every individual in this world is his family. The family is the most important part of a man's environment.



The first contact of an individual in his environment is through his family. As civilization advanced the family continued to change which become more eminent due to industrialization and urbanization. Hence it is important to examine and understand the structure of the family in the modern setting.

In general, the family life cycle can be divided into three major stages.

- The beginning family
- The expanding family
- The contracting family

4.4.1 Nuclear Family

The nuclear family is the traditional type of family structure. This family type consists of parents and children. The nuclear family was accepted by society as the ideal family type to rise. Children in nuclear families receive strength and stability from the parents and generally have more opportunities due to the financial ease. Today's generation live in a nuclear family unit.

4.4.2 Single Parent Family

The single parent family consists of one parent raising one or more children on his own. Mostly a single parent family is a mother with her children and there are single fathers as well. The single parent family is the biggest change in the society which has changed the family structures. Single parent families are close and they have to solve problems and divide their household chores. In this type of family only one of the parents will be employed. This will limit the income and their opportunities.

4.4.3 Extended Family

The extended family structure consists of two or more adults who are related, either by blood or marriage living in the same home. This type of family includes many relatives living together and working towards common goals such as raising the children and managing the household duties. The extended families include cousins, aunts or uncle and grandparents living together. This type of family structure has more financial difficulties because older relatives are unable to care for themselves alone. Extended families are becoming increasingly common all over the world.

4.4.4 Childless Family

Majority of people think of family as including children, they are couples who either cannot or choose not to have children. The childless family is sometimes the "forgotten family" as it does not meet the traditional standards set by society. Childless families consist of a husband and wife living and working together. Many childless families take on

the responsibility of pet ownership or will have their nieces and nephews as a substitute for having their own children.

4.4.5 Step Family/Blended Family

Now days many marriages end in divorce and these individuals choose to get remarried. This creates the step or blended family which involves two separate families merging into one new unit. It consists of a new husband and wife and their children from previous marriages. Step families have more problems, such as adjustment periods and discipline issues. Step families need to learn to work together to ensure these family units run smoothly.

4.4.6 Grandparent Family

Many grandparents today are raising their grandchildren for a variety of reasons because the parents are not present in child's life. This could be due to parent's death, addiction, abandonment or being unfit parents. Many grandparents need to go to work to find additional sources of income to help raise their grandchildren.

4.5 Budget

A budget in general is a detailed plan of operations for some specific future period. Budget helps to plan and control the income and expenditure. There is a close relationship between the family income and the expenditure on clothing.

Benefits of Budget

- An individual who lives within a planned budget is usually happier, more contented than the one who spends one's money as one earns it.
- Budgeting helps a household to spend money carefully.
- It is an intelligent guide to spending wisely.
- It balances the future and the present wants, making suitable allocations for spending and saving.
- Money is the major factor that either supports or inhibits any interest. When sufficient amount is available naturally, they express higher interest in fashion.

4.6 Budget Planning

The secret of managing money well is in planning. Budget is only a plan for spending. It helps to meet necessary expenses and help to afford to buy extras one wants to buy and save. It also helps to avoid over spending. There is no single pattern for spending and saving that suits everyone. Income differs, needs and wants must be taken into account, and expenses differ. This means that each person must make his own plan. Following are some general suggestions for planning your budget.

- A budget should eventually be planned to cover expenditures and savings for a year
- To get started you can plan month by month. At the end of the first year the records and experience may help to plan more wisely for the next year
- First estimate your total income. This includes mortgage or rent payment, electricity, food insurance, loan payment and transport costs
- Next keep a record of your expenditures for atleast a month before you start to work out your budget. Such a record

will give a picture of how you spend your money and will help you plan your spending

- Determine the amount that will be required for fixed expenses. These items include rent, utilities, insurance payments, direct taxes such as property and wage, car payments and other instalment payment. List them and plan how much money to spend for them
- Then estimate the cost of other necessary expenses such as food, clothing, transportation, health care and personal care
- The remainder of the income must cover all other items in the budget. These are the items that represent a person's particular interests and desires such as education, recreation, contributions, hobbies, gifts and savings
- Do not make the mistake of planning to save money that is left over. It is improbable that anything will be left to save. Plan the amount that you intend to save at the same time you budget all other items
- Record your individual budget plan – don't trust memory

4.7 Clothing Budget

A budget is a detailed plan of operations for some specific future period. Clothing budget helps to plan and control the income and expenditure. There is a close relationship between the family income and the expenditure on clothing. Budgeting helps a household to spend money carefully. It is an intelligent guide to spending. It balances the future and the present wants, making suitable allocations for spending and saving.

4.7.1 Clothing Budget for a Family

Clothing the family can be expensive especially when the children are in growing stage. The budget will help to restrict from impulse buying and buy when family absolutely needs them. It is best to invest in few garments that can be matched with that existing one in the wardrobe and that can be worn in a variety of styles.

Should take advantage of end-of-season clearance sale especially winter clothes-one can find discount sale of winter clothing at the end of March or April and summer sale at the beginning of August and September. During this time if we purchase clothing for teenagers and older children one can find significant savings.



How much you should spend on your clothing?

You can spend 5% of your monthly income on clothing. To find the exact amount you should be spending per month, multiply your take-home pay by 0.05.

For example, if your monthly take-home pay is Rs.3000, you should spend around Rs.150 per month on clothing.

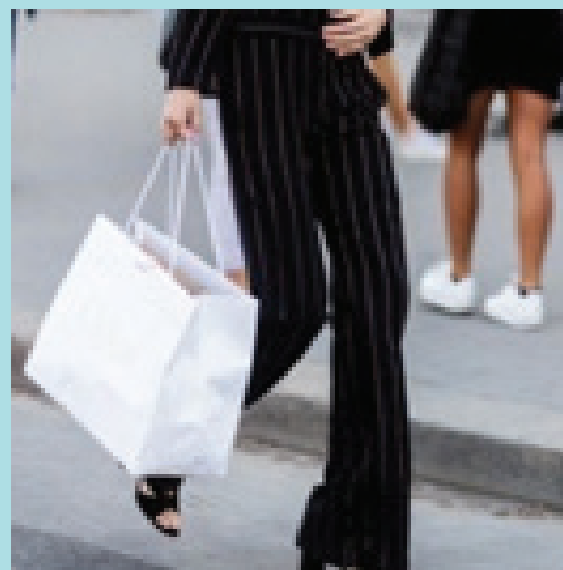

Before going for shopping for new clothes the family members must go through their closets and remove clothing that they do not wear or outgrown. Creative thinking and flexibility are the keys to keep one's family budget intact.

4.8 WARDROBE PLANNING

Definition

The wardrobe planning is to select clothes that are so basic in style and good in design that they are appropriate for the present set up as well as suitable for a few years to come. To device maximum satisfaction one must develop good clothing practices. Good clothing practice includes the knowledge of wise selection of clothing, possession of an adequate wardrobe suited to various occasions which in turn helps in proper dressing habit.

- Wardrobe planning is influenced by many factors. The most common are Aesthetic, psychological, sociological and economic factors.
- Individual taste, social surroundings and family income.
- Age, sex, occupation of the family members.
- Durability, quality of clothing items, price, appearance and ease of care.
- The climate conditions, activities of a person, state of health.
- Fashion and lifestyle.

4.8.1 Steps in Wardrobe Planning

- Sort and Purge

Remove items from your closet and drawers. As you remove items, sort them into one of four items:

- “Store” (for seasonal items)
- “Repair/Clean” (items which need hemming, buttons, cleaning)
- “Donate” (Useable items with no repairs or cleaning needed)
- “Toss” (items that are too worn or cannot be repaired)

If we haven't worn something for a year, definitely it should be donated or toss it. Once the items are removed, bag them up to send to their respective places. Items to be stored in vacuum-storage bags and put under the bed or in your storage locker; anything to be repaired or cleaned needs to be taken immediately to the drycleaner can be obviously tossed.



When was wardrobe invented?

The word wardrobe appeared in the English language in the early 14th century. It originated from Old French word warderobe, wardereube and garderobe, in which “warder” meant “to keep, to guard” and “robe” meant “garment”. Therefore wardrobe a collection of clothes for an individual existed even during the early 14th century.



- Shop in Your Own Closet

Once you have finished sorting and purging, make a note of the items that are left in your closet and drawers. Group

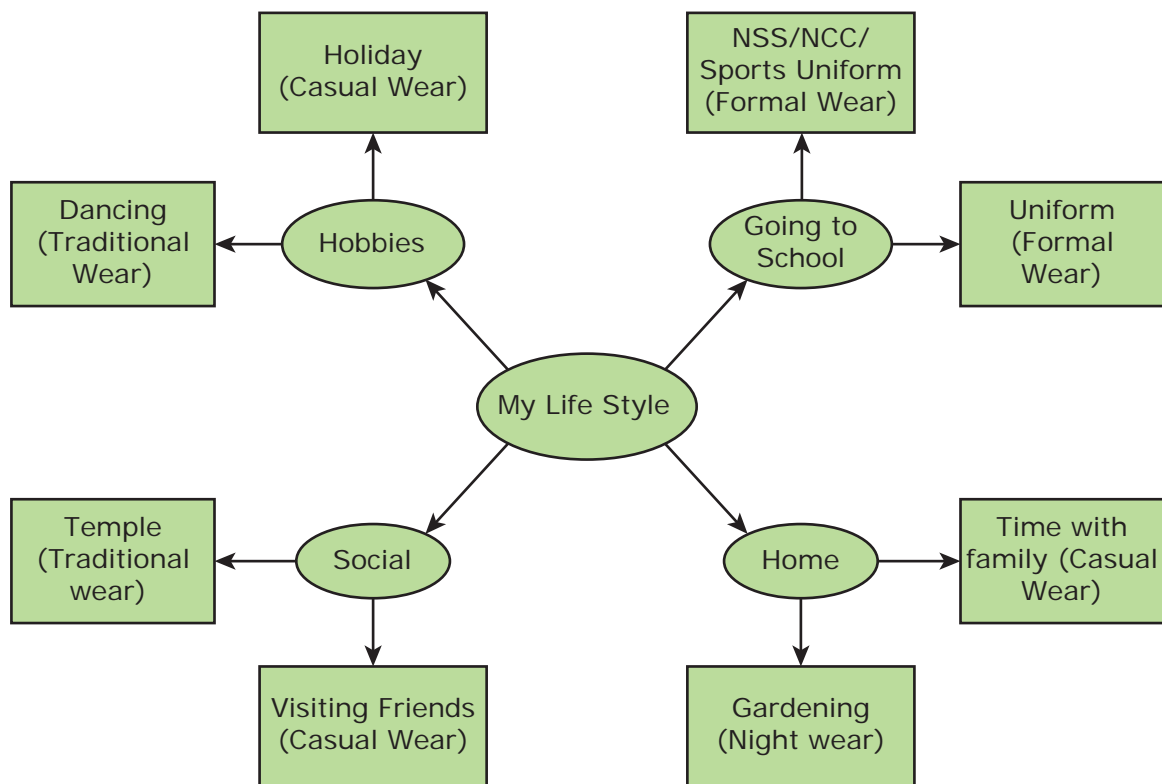

Figure 4.1 Clothes based on Activity of a School going Girl

them according to type; formal wear, casual wear, fancy wear, accessories, mix and match items to create new outfits.

- **Make a List**

In order to follow mixing and matching, make a list of the items you need to purchase to complement your existing one. Make a note of new clothes to be purchased. This list is the basis of your wardrobe plan.

- **Set Your Budget**

Estimate the cost of the garments need to purchase.

- **Determine Time and Place**

Decide what time of year each piece needs to be purchased and what to purchase these items. For example, a great time to purchase a winter coat for cost savings is actually at the end of winter. The choice of store is determined by your budget and

location. Allocate time and funds from your budget for shopping. Once per season is the recommended. A minimum of two hours should be allocated to each shopping.

- **Finalizing the Wardrobe**

After following the basic steps to create a plan for your wardrobe, shopping is much easier and far more cost effective. Organize your wardrobe to get the maximum efficiency and minimize the stress associated with getting dressed in the morning.

4.8.2 Wardrobe Planning for a Higher Secondary School Going Girls

Clothing is of greater importance during teenage than during any other period. It is a fascinating period of transition brought about by the onset of puberty. Profound physical changes, new found cognitive

ability, increased social pressure and a new educational environment exerts a strong influence on the developing individual. It is a time of insecurity and a period of heightened interest in clothing. It is a period in which clothes have a greater effect upon the individual. During this stage they realize that clothing can do much to improve appearance and camouflage an unattractive appearance.

The higher secondary school going girls has a wide range of choice for clothes open to her ranging from the traditional to the most modern. In fact, most girls today wear a mixed array of clothes like – jeans, T-shirt, skirt and blouse, churidar-kurta, lehenga choli, half sari.

Some girls feel that they could dress well if only they had a lot of money to spend on clothes. Of course, money do help. But it is possible for a girl from an average income family to appear better dressed than a girl whose family is in the upper income group. It isn't the money spend on a wardrobe but the thought that is put into selecting it that really counts. Various dresses may be selected according to the role an individual has to play. Hence for travelling, working, playing and sleeping purposes different outfits are used.



Figure 4.2 Wardrobe Planning for Higher Secondary School going Girls

4.8.3 Wardrobe Planning for Higher Secondary School Going Boys

Today teenage boys are becoming more and more fashion conscious, more sophisticated and more selective. They are exposed to and have access to information about everything like never before. The higher secondary school going boys have many things in common. They have to select clothes suitable for different occasions – school, formal, informal, parties, sports and traditional wear. Their wardrobe is mainly made up of basics like undergarments, jeans and T Shirts. For casual wear they prefer short, Bermudas, track pants and T Shirts. The teenagers like to try new fashions and update their wardrobe. The biggest expenses in the

Table 4.1 Clothing Items based on Activities of a School going Girl

S. No.	Activities	Clothes needed	Approximate Number Required
1.	Sports	T- Shirts, Shorts, Track suits	2 of each
2.	Casual Wear	Jeans, tops, skirts, Leggings	2-3 of each
3.	Formal Wear	Salwar kameez, Chudidar, Patiyala	4 of each
4.	Party Wear/ Function Wear	Lehenga Choli, Half sari, Salwar Kameez.	3 of each
5.	Night Wear	Pant, T-Shirt, Nighties	2-3 of each
6.	Under wear	Panty, Slip, Bra	4 of each

Table 4.2 Clothing Items based on Activities of a School Going Boy

S. No	Activities	Clothes needed	Approximate Number Required
1.	Sports	T-Shirt, Shorts, Track Suit	2 of each
2.	Casual Wear	Shorts, T-Shirt, Track Suits, Jeans	3 of each
3.	Formal Wear	Shirt and Pant	4 of each
4.	Party Wear/ Function wear	T- Shirt and Jeans, Kurta, Pyjamas, Dhotis	3 of each
5.	Night Wear	Shorts and T- Shirts, Pant, Bermudas	3 of each
6.	Under Wear	Brief, Vest	4 of each

clothing budget are shoes. The clothes worn by teenage boys must be suited to the wearer, the seasons of the year, the time of the day, the occasion to which they are to be worn and accepted style of the day. The boys are more conscious about their personal appearance and peer group acceptance, try to change their clothing behaviour and always attempt to be on par with current fashion.



Figure 4.3 Wardrobe Planning for Higher Secondary School Going Boys

Division of Budget

A budget should eventually be planned to cover expenditures and savings for a year. To get started you can plan month by month.

Outer Garment	48 to 54 %
Undergarments and Sleeping garment	8 to 13 %
Shoes and Socks	18 to 27 %
Accessories	4 to 8%
Sports Clothes	0 to 4 %

4.9 SUMMARY

Clothing is one of the most personal and important components of daily life and at the same time it is an expression of social activities deeply embedded with the cultural patterns of an era. Today everyone wants to look and appear attractive regardless of age, occupation, rural and urban background. Clothes also have a significant effect on physical, emotional, social and mental well-being. Planning a clothing budget will help to have an idea on expenditure. An individual who lives within a planned budget is happier, more contented than the one who spends one's money as one earns it. The wardrobe collection should not only be beautiful, fashionable and suitable for the body but it should also be comfortable. The important reason for planning wardrobe was to check for adequacy and to get co-ordinated wardrobe.

POINTS TO REMEMBER

- Right clothes are necessary for health, poise and self-respect.
- Clothing selection is influenced by aesthetic, psychological, sociological and economic factors.
- Budget helps to plan and control the income and expenditure.
- A budget should eventually be planned to cover expenditure and savings for a year.
- There is a close relationship between the family income and the expenditure on clothing.
- Clothing the family can be expensive especially when the children are in growing stage.
- Clothing is of greater importance during teenage than during any other period.

ACTIVITIES FOR TEACHER

- To show different types of garments suitable for family members.
- To arrange for a visit to shopping malls to know about the latest trends.

ACTIVITIES FOR STUDENTS

- To ask students to design wardrobe for different age groups.
- To plan clothing budget for different age groups.



INTERNET RESOURCES

https://www.youtube.com/watch?v=vge8JqkYwKY	What is your budget for clothing?
https://www.youtube.com/watch?v=xjDH4zl4Ha4	What is Budgeting and Planning?

A-Z GLOSSARY

Budget	A budget (from old French baguette, purse) is generally a list of all planned expenses and revenues.
Wardrobe	A large, tall cupboard in which clothes may be hung or stored.
Extended Family	A family which extends beyond the nuclear family to include grandparents and other relatives.
Blended Family	Family consisting of a couple, the children they have had together, and their children from previous relationships.
Closet	A cupboard or wardrobe, especially one tall enough to walk into.
Budgeting	Provide (a sum of money) for a particular purpose from a budget.

QUESTIONS AND ANSWERS

PART – I

Objective Questions

1. Clothes make an important major category in the
 - a) Family Budget
 - b) Business Budget
 - c) Wardrobe
 - d) Storing
2. A wardrobe is a standing closet used for _____ clothes
 - a) Hanging b) Storing
 - c) Folding d) Using
3. The first contact of an individual in his environment is through
 - a) Neighbour
 - b) Relatives
 - c) Family
 - d) Friends
4. Which family includes relatives living together
 - a) Extended Family
 - b) Blended Family
 - c) Nuclear family
 - d) Single Parent Family
5. The _____ family consists of two separate families into one
 - a) Extended Family
 - b) Single Parent Family
 - c) Blended Family
 - d) Nuclear Family



PART – II

Answer in Three (Or) Four Points

1. Give the importance of family clothing.
2. What is nuclear family?
3. Define budget.
4. Write a note on clothing budget.
5. Define wardrobe.
6. Describe the wardrobe planning for higher secondary school going boys.

PART – III

Answer in a Paragraph

1. Discuss on the family clothing.
2. Brief a note on types of family.
3. Explain budget planning.
4. Write the steps to be carried out in wardrobe planning.
5. Describe the wardrobe planning for higher secondary school going girls.

PART – IV

Answer in One Page

1. Elaborate on the clothing budget for a family.
2. Enumerate on wardrobe planning.

Answers for Objective Questions

1. (a) 2. (b) 3. (c) 4. (a) 5. (c)

Selection of Clothing and Clothing Care

CHAPTER

5



LEARNING OBJECTIVES

- To learn about the method of selecting clothing and its care.
- To understand the types of clothing care methods.

5.1 Introduction

Clothing protects the human body from extreme weather and other features of the environment. The practical function of clothing is to protect the human body from environmental hazards such as weather, insects, toxic chemicals, weapons and other hazards.

5.1.1 Factors Affecting Clothing Selection

The clothes that you choose to buy and wear are influenced by several factors such as age, climate, occasion, income and occupation.

● Climatic Factors

People living in cold climate need to wear woollen clothes to keep warm. People living in very hot climates as in deserts

need to wear turbans of thick cloth to protect their heads and wear garments made of cotton to stay cool.

● Occasion

Bright coloured garments are worn during marriage functions for eg., lehanga cholis, ghagras and shararas often accompanied by bright accessories. Simple clothing with minimum accessories like a formal salwar kameez will give a more professional look for an interview. Sari, formal trousers shirt, tie would be a good option for the wearer to feel active and confident.

● Age

Clothes worn by an adult woman are definitely not the same as those worn by a college going girl. For small children dainty prints in soft colours can be chosen. When children enter late childhood stage, boys like masculine colours like blue, greyish blue and brown and girls like to wear feminine colours like pink, green, red etc. Teenagers like to have variety in their clothes. Selection of clothes for adults depends upon the type of work a person is engaged.

- **Income**

Income affects the selection of clothing. High income group spend more percentage of money on clothing as compared to low income group. They spend more money on fashionable garments rather than on durable clothes. People belonging to low income group prefer durable clothes rather than delicate ones. So, the preferences of the clothing changes according to the income of the family.

- **Occupation**

Many professions have a specific dress code which gives them a special identity. For example: People working in the hotel industry, airlines, traffic policemen, security guards, etc. Certain specialized activities require special apparel. For example: Special overalls are worn in the laboratory, during mixing chemicals for pest control by people or by those who work in nuclear power plants. They protect the workers against radiation hazards. Firemen wear apparel made of fireproof fabrics.

5.2 Clothing For Family Members

Clothing for Newly Married

Many of the newly married do not plan their post marriage wardrobe. Their wardrobe should be a balance of western wear and ethnic wear for various occasions. They should select clothes for different occasions. The colours selected should enhance the colour of skin. The garments and accessories selected should reflect their personality. Figure irregularities must be considered.



Figure 5.1 Clothing for Newly Married

- **Clothing for Expecting Mothers (Maternity Wear)**

Maternity clothes around the world have been undergoing significant changes. There is greater demand for fashionable maternity clothes. Nowadays pregnant women are no longer trying to hide their “Baby Bumps” instead chooses to wear garments which fit their new shape often emphasizing the bust and abdominal area. There are many brands which produce everyday wear for pregnant women. As the body shape is changing the maternity clothing is made with Lycra and elastic for stretch and growth.



Figure 5.2 Clothing for Expecting Mothers



● **Clothing for Lactating Mothers**

Lactating mothers can purchase readymade clothing which is plenty in designs and styles to choose from. They need not buy special breast-feeding clothes to breastfeed comfortably. A button down blouse can be quickly opened. Dark colour fabrics should be selected that will hide any unexpected leaks much better than light colours. Scarves and shawls are great accessories that can cover leaks and provide privacy while breast feeding in public. Tight fitting garments should be avoided. Variety of casual wear, formal wear and professional outfits are available especially for breastfeeding moms in maternity shops and online.

Right breastfeeding clothes will be very helpful to new mothers. Breastfeeding fashion has come a long way. Nursing shirts and blouses are available in different styles and colours. Nursing bras are must in wardrobe for lactating mothers. A good nursing bra should be comfortable, fit well and provide support for heavy milk filled breasts. It should be made from a natural, breathable, absorbent fabric with soft cups.

Nursing sleepwear helps easy access to your breasts for night time feedings. Breast feeding clothes have become much more stylish and women enjoy wearing these garments.



Figure 5.3 Clothing for Lactating Mothers

● **Clothing for Infant (8 to 9 Months)**

The three “musts” in clothing the new born baby are warmth, comfort and hygienic qualities. The new born baby will react to the variable temperature of new environment. Babies heat up and cool off more quickly than do grown-ups. The new baby is more subject to fever producing infections, many of which can be transmitted by clothing if care is not exercised. During the first few months of life, the baby will sleep 80 per cent of the time and must have comfortable clothing for sleeping. The most suitable fibre for infants clothing is cotton, because it is soft and can be kept hygienically safe by washing in extremely hot or boiling water.



Figure 5.4 Clothing for Infants

● **Clothing for Creeper (8 Months to 1 Year)**

More clothes are required when the baby begins to creep. Overalls are the simplest form of garment for both sexes especially those with snaps in the crotch help easy change of diapers. Strong and durable fabrics are suitable for this age group. They crawl on the floor; fabrics from



knees wear off due to friction. Garments with adjustable straps are more suitable due to growing stage.



Figure 5.5 Clothing for Creepers

● Clothing for the Toddler (1 to 2 Years)

The toddler needs clothing that provides maximum freedom for all the activities usual at this stage. Overalls are preferred. One piece garments with gripper openings at the legs or crotch are commonly worn by toddlers, although one-piece clothing is soon outgrown because of the rapid growth in this period. During creeping and toddling years, one piece pyjamas are usually safer and neater than two-piece ones. Pyjamas should be made of soft washable materials.



Figure 5.6 Clothing for Toddlers

● Clothing for the Pre-School Child (2 to 4 Years)

Clothing for the pre-school age child may be a major problem for the family because it is expensive and used only for a short time. Clothing should be selected to help the child develop self-reliance, practice social skills and interact with peers. Garments should be flexible, comfortably warm, easily cleaned, soft, convenient for frequent toileting, adjustable to the rapidly growing body and attractive in design and fabric.

The wardrobe of the pre-school child must be chosen with as much care as that of any family member. Many factors affect the size and content of child's wardrobe. The pre-school child needs clothing that fits close to the body and is free from dangling ties or ornamentation that might catch on things. Growth is more rapid during the pre-school years. Buying clothes with growth features will enable a garment to be worn over a longer period of time.



Figure 5.7 Clothing for Pre-School Going Children

● Clothing for School Going Children (5 to 11 Years)

Clothing requirements vary for elementary school children in some respects than pre-schools although many requirements remain the same. This period is a very active one physically. Their likes and

dislikes about clothing will develop. Durable clothing must be provided which withstand the strains of physical activity. Boys enjoy wearing clothes that look rugged, shirt hanging out; heavy shoes and jeans are often popular. Safety, easy care, growth allowances and suitability to figure and complexion of child should be considered while selecting clothes.



Figure 5.8 Clothing for School Going Children

● Clothing for Pre-Adolescents (12 to 15 Years)

There will be a rapid change in the body and taking on adult characteristics during pre-adolescent period. There will be increased interest in clothes and grooming up. The pre-adolescent is more interested in their relationship with others. They give more importance to becomingness, price and beauty than to durability and comfort. Psychological comfort plays an important role while selecting clothes. Physical comfort is given less importance. Physical comfort is related with the types of clothing whereas psychological comfort indicates the satisfaction the wearer.



Figure 5.9 Clothing for Pre-Adolescents

● Clothing for Adolescents (15 to 20 Years)

During this period adolescents are learning to manage their body so they are less awkward. Both sexes seek increased approval from members of opposite sex. They become more conscious of grooming and personal appearance. They prefer well fitted, fashionable and expensive garments. Comfort and serviceability are sacrificed for the sake of style and fashion. Clothing becomes a means of expressing personality. As adolescents are developing physically they either want to conceal or show off their figure.



Figure 5.10 Clothing for Adolescents

● Clothing for Adults

A person is mature enough to select the clothes on the basis of income, status, occupation, climate, age, sex, occasion, fashion etc. A well-dressed person feels more confident and more capable of himself. A man's wardrobe is different from a woman. Man's wardrobe includes shirt, trousers, shorts, socks, ties, shoes, nightwear, suit, etc. Extent of woman's wardrobe depends on family income, their social activities, her profession and all other factors required for men's clothing. Clothing items depends upon profession of a person. Working woman needs more clothes as compared to a housewife. Persons who are socially active need more clothes for formal occasion, for kitty parties, clubs, marriages

etc. Socially active persons are fashion and status conscious.



Figure 5.11 Clothing for Adults

● Clothing for Elderly

The bodily characteristics will be changing so it is necessary to solve the problems of fit and select designs and colours which are becoming to the age group. The body not only gains in weight after the middle years but the distribution of weight also shifts. There is general sagging of the body. These create problems in selection of readymade garments as they are made based on standard measurements. It is usually found that most of the elderly people start wearing light coloured clothes. Heavy clothes are also not comfortable and so they require dresses made of light weight fabrics with enough warmth or coolness.



Figure 5.12 Clothing for Elderly

● Clothing for Old Age

Old age is the concluding phase of life. Old age brings its own problems. The body

becomes stiff, the eye sight becomes weak and energy level is considerably reduced. The clothes they wear must be loose and comfortable rather than fashionable. Dressing and undressing takes more energy than anything. It is advisable for old age people to have clothes with front opening with large buttons so that it is easy to use.

In addition many older people are affected with arthritis and other diseases of joint and muscles which greatly increase the problems. Rough textures and heavy fabrics may irritate their skin. Their clothing should be warmer in winters and cooler in summers. As the old age people are less active physically their clothes do not wear out rapidly.



Figure 5.13 Clothing for Old Age

5.3 Clothing Care

Introduction

All fabrics and clothing's need proper care in order to maintain their lustre, texture, shape, appearance and strength. The life of fabric increases with proper care. Due to cost and importance of clothing's their proper care is always required.

5.3.1 Washing

Washing clothes is an important skill. Washing is one way of cleaning namely with water and often some kind of soap or detergent. It is an essential part of good hygiene and health. Getting clothes clean is not hard if the correct methods and laundry products are used.

5.3.1.1 Principles of Washing and their Applications

Home laundering is one of the most important and common household chores. Humans have developed many specialized methods for laundering, ranging from the earliest pound clothes against rocks in running stream to the latest in electronic washing machines and dry cleaning.



The dirt which soils fabrics may be classified as

1. Loose dirt on the fibres.
2. Fixed dirt which is held fast by grease.

Loose dirt is removed in steeping and mechanical means such as brushing and

shaking. Fixed dirt is removed by means of absorption, washing and dry cleaning.

5.3.1.2 Hand Washing

Hand washing is vital for clothes, fabric and dyes that cannot take the stress and strain of machine agitation and spin. It is very practical for a small wardrobe and is the best way to prolong the life of a piece of clothing.



Who invented the Washing Machine?

The earliest washing machine was the scrub board invented in 1747. American James King patented the first washing machine to use a drum in 1851. In 1858, Hamilton Smith patented the first rotary washing machine. It was a machine which removed and washed away dirt from clothes



The appropriate method for the treatment of dirt and kind of rubbing is given below:

Table 5.1 Method for the Treatment of dirt and kind of rubbing

Method of Washing		Process	Use
I. Friction Washing			
a.	Hand Friction	<ul style="list-style-type: none"> ● Wring the article out of the steeping water. ● Apply soap to the most soiled parts and rub until the dirt loosened. ● Rinse out all soap with warm water 	<p>Suitable for cleaning much soiled small articles made of cotton or linen.</p> <p>Suitable for cleaning much soiled small articles made of cotton or linen.</p>
b.	Friction by use of a scrubbing brush	<ul style="list-style-type: none"> ● Wring the article out of the steeping water. ● Spread on a flat surface and rub over with soap ● Rinse out the soap in warm water. 	Suitable for very soiled household articles of any coarse strong fabrics.

c.	Friction by use of the rubbing board	<ul style="list-style-type: none"> ● Washing is carried out in a deep sink. ● Place a part of the soiled cloth on the rubbing board and soap well. ● Rinse well in warm water. 	
II.	Suction washing friction with a suction washer	<ul style="list-style-type: none"> ● A suction washer consists of non-rusting material. ● It may be of small size or large size. ● Make a permanent lather on the water with soap solution or soap flakes. ● Immerse the soiled article in soapy water and repeatedly press suction washer down on the article. ● The vacuum formed causes the soapy water drawn through the clothes. ● The repeated suction of the soapy water through the clothes cleanses the fabric. 	<p>It is a quick and practical method of cleansing large quantities of soiled articles.</p> <p>It can be used on garments of any fabric and colour.</p>
III.	Washing by kneading and squeezing	<ul style="list-style-type: none"> ● Knead and squeeze the soiled fabric in warm soapy water without lifting out of the water. ● Very soiled parts should be placed on the palm of the left hand and should be kneaded and squeezed until the dirt is loosened. ● Rinse thoroughly to remove all traces of soap. 	



Figure 5.14 Scrubbing Board Suction Washer

5.3.1.3 Washing by Machine

A washing machine is a machine designed to clean laundry such as clothing, towels and sheets. Clothing had been hand

washed for thousands of years to remove loose dirt, rubbing with soap to remove oils and stains. For particularly dirty clothing covered with mud or dirt, it is necessary to constantly rub and flex the cloth to break apart solids and help the soap penetrate through thick, dry or sticky layers of soil on the cloth.

Washing machine technology was developed to reduce the drudgery of this scrubbing and rubbing process.

Before using a washing machine it is important to study the maker's instructions.

A typical household machine takes a load of 6 to 7 lb. The machine should never be over loaded.

- When washing a load of mixed fabrics wash according to type of fabric.
- Collars and cuffs may need a gentle rub by hand to remove completely the already loosened dirt.
- Give time according to the articles being washed.
- Rinse thoroughly.



Figure 5.15 Washing Machine

Types of Washing Machine

Although most washing machines have same basic functions each machine may be slightly different so it's very important to read instructions. Washing machines are either front loading or top loading machines. For front loading washers, the door is located on the side in front while top loading machines have the lid on the very top of the washer. Most washing machines have several settings that will determine the correct temperature of the water and the length of each spin cycle.



Front Loading

Top Loading

Figure 5.16 Types of Washing Machine

5.3.2 Fabric Softeners

Fabric softener (called fabric conditioner) is used to prevent static cling and make fabric softer. Some brands of washing powder have fabric conditioning built-in which is claimed to save money when compared to buying ordinary washing powder and fabric softener separately.

Fabric softeners work by coating the surface of the cloth fibres with a thin layer of chemicals. These chemicals have lubricant properties and are electrically conductive, thus making the fibres feel smoother and preventing build up of static electricity. The other functions are increased resistance to stains and reduction of wrinkling.

5.3.2.1 Types

Fabric softener are classified into two types

- Cationic Fabric Softeners
- Anionic Fabric Softeners

● Cationic Fabric Softeners

Cationic fabric softeners usually contain cationic surfactants of the quaternary ammonium type as the main active ingredient. Cationic surfactants adhere well to natural fibres but less to synthetic



fibres. This softener should be added in the rinse cycle of washing machine. Fabric softener reduces the absorbency of textiles, which adversely affects the function of towels and microfibre cloth.

Conventional softeners, contain 4–8 % active material, which have been partially replaced in by softener concentrates having some 12–30 % active material.

● Anionic Fabric Softeners

Anionic softeners and antistatic agents are often used together with the conventional cationic softeners. Cationic softeners are incompatible with anionic surfactants in detergents because they combine with them to form a solid precipitate. They should be added in the rinse cycle. Anionic softeners can combine with anionic surfactants directly. Some compounds, such as ethoxylate phosphate esters, have softening, anti-static, and surfactant properties.

5.3.2.2 Method of using Fabric Softener

- After pouring in detergent, locate the fabric softener dispenser on your machine.
- Pour in the recommended amount.
- If your machine doesn't have a specific dispenser, you will have to manually add the fabric softener during the last rinse cycle. Do not add fabric softener to the main detergent dispenser because it needs to be used at the end of the wash cycle.
- Never pour fabric softener directly on to clothes.

- Alternatives to using fabric softener can be used as dryer sheets or a combination of detergent with fabric softener.

Most modern washing machines have a dispenser to add liquid fabric softener to the load of laundry automatically on the final rinse. Some brands of washing powder have fabric conditioning it is claimed to save money when compared ordinary washing powder and fabric softener separately.

5.3.3 Starching

Starch is most commonly and widely used stiffening agent. The most appropriate starch for use in laundry is one which penetrates the fabric well to make pliable, smooth and glossy that will prevent direct contact of dirt with fabric. A stiffening starch is applied to cotton and linen fabric only.

5.3.3.1 Types of Starches

The different kinds of starches commonly used as stiffening agents are;

● Rice Starch

The grains of this starch are very small and make a viscous solution in water. This starch is suitable for most fabrics. Since starch gelatinizes easily in cold water, it is known as cold water starch. As the size of grains are very small, this penetrates easily into the fabrics.

● Wheat Starch

The grains of this starch exist in two sizes large and small. This starch forms a viscous solution leaving fabric very stiff and pliable. It requires boiling of solution and is very uneconomical and expensive.



- **Maize Starch**

This starch also gives a viscous solution. But it produces undesirable stiffness which is rough to touch. It is cheap and hence can be used after mixing with other starches.

- **Tapioca Starch**

The starch is obtained from roots of cassava plants. For this purpose the roots are dried, sliced and then crushed into pulp with water. It is then washed several times and then dried when the final starch becomes available in the form of lumps which can be ground.

- **Potato Starch**

This starch has largest grains of all the starches. Potato and sweet potato are used. Potato is ground to pulp washed several times and then water is evaporated. It is not a very suitable laundry stiffening agent.

- **Commercial Starch**

Various types of commercial starches are available in the market. These are made by blending two or more different types of starches.

5.3.3.2 Preparation and Application of Starch Solutions

- **Boiling Water Starch**

Preparation of Standard Starch Jelly

Ingredients

Starch	1 tbsp.
Coldwater	2 tbsp.
Borax	1 1/4 tbsp
Wax	1/4 tbsp.
Boiling water	500 ml

Procedure

Mix the starch in cold water to a smooth paste in a basin. Add borax and wax (The

function of borax is to make the starch resistant to atmospheric condition. Wax is added for easy ironing of the fabric). Then pour boiling water till the colour of the solution is transparent. A little formalin can be added to this jelly to avoid microbial spoilage.

Application on Fabrics

The standard starch jelly is diluted with cold water depending upon the amount of stiffness required.

- **Cold Water Starch**

Preparation of Starch Solution

Ingredients

Rice starch	1 tbsp
Borax	1/2 tbsp
Turpentine	3 drops.
Coldwater	250 ml
Boiling water	1 tbsp.

Procedure

Dissolve borax in boiling water and mix with cold water. Pour the mixture over starch followed by turpentine. Stir well till a viscous solution is formed. Strain the starch solution through a muslin cloth and use after half an hour.

Application of Starch

This rice starch is used to provide great stiffness.

For Example the cuff and collars, the fabric should be dry before starching. The article is then kneaded and squeezed in the starch solution. It is then rubbed with a muslin cloth to remove excess starch. The article is then wrung out tightly in cold water.

DO YOU KNOW? How to make rice starch at home?

Powdered rice or cooked cold rice is taken and grinded until smooth. This should be mixed with cold water and the clothes can be soaked for 10 mins. The fabric is then washed, ironed to enjoy the stiffness of the material on wearing.



● Wheat – Bran Starch

The outer husk of wheat is known as wheat bran. With water it forms a colloidal non-alkaline solution, having small amount of starch and proteins. This is a very useful starching agent for fabrics of uncertain dyes and embroidered clothing. Bran water cleanses and stiffens the fabrics, besides preserving their colour.

Preparation of Wheat Bran Starch Solution

Ingredients

Wheat Bran	1 Part
Cold Water	4 Parts

Procedure and Applications

Boil wheat bran with water in a pan. When boiling starts lower the heat and simmer for half an hour. Strain the solution through muslin cloth. Cool the starch to room temperature and use for washing and rinsing. Soap solution can be added for very soiled articles. The article is ironed when it is half dry.

Gum Arabic

This gum is used on fabrics requiring light stiffening. It is marketed in both granulated as well as powdered form. Granulated gum dissolves more readily than the powdered one. This is formed of arabic acid, lime, magnesium and potassium salts.

Preparation of Gum Arabic Solution

Ingredients

Gum Arabic	112 g
Boiling Water	500 ml

Procedure and Application

Dissolve the gum arabic in water. Stir well to dissolve gum arabic to form a clear solution. Dip article in the solution by steeping. Squeeze the excess solution by light pressing and dry in air. Gum arabic is an expensive stiffening agent.

● Borax

Preparation of Borax Solution

Ingredients

Borax	4 tbsp.
Water	250 ml

Procedure and Application

Mix borax in water. Immerse the clothing into this solution by kneading and lathering. Lightly squeeze excess solution and air dry. Borax gives light stiffening to fabrics like laces.

5.3.4 Laundry Blues

The laundry blues are used to remove the yellow tint of fabrics, yellow tint in fabric arises due to repeated washing. In the last rinse of washing cotton and linen, laundry blue is added.



5.3.4.1 Types of Blues

Depending upon their solubility in water, blues are classified into two categories:

1. Insoluble Blues

Do not form clear solution in water. e.g., Ultramarine and Persian blue.

2. Soluble Blues

When dissolved in water, form clear solutions. e.g. Coal-tar dyes, methyl violet and methylene blue.

5.3.4.1.1 Insoluble Blues

● Ultramarine Blue

This is more commonly used laundry blue. It can be safely used on the fabrics. This does not have any harmful effect. It is made from chemicals like, soda ash, sodium sulphate, charcoal, sulphur and clay. It is available as a fine powder which forms an even micro-suspension in water.

● Persian Blue

This is not commonly used. This is undesirable as it is formed from iron sulphate and potassium ferrocyanide. This gives rusty marks when the treated fabric is ironed.

5.3.4.1.2 Soluble Blues

All the soluble blues are chemical dyes. These are available in large number of varieties. These are employed in commercial laundries. These are preferred in laundries because insoluble blues, produce an even colour and leave no sediment.

5.3.4.2 Bluing Process

Bluing is done as the last rinse of the fabric after washing. For this purpose care should be taken that no soap is left in the fabric before bluing. The blue is tied in a muslin

cloth and squeezed in cold water until the required colour in water is obtained. The articles are dipped in the solution once or twice, taking care that after taking out no solution is left filling in pockets or bag shaped parts. The blued fabric is then squeezed off to remove excess solution and dried.

5.3.5 Drying Equipments

The washed clothes can be dried conveniently under direct sun rays when sufficient open space is available. The lack of open area in urban areas has stressed the need for other appliances. These appliances can be used for drying of clothes in limited space, as well as in rainy seasons. The commonly used appliances under such situations are;



Figure 5.17 Foldable Drying Rack

5.3.6 Outdoor Drying

Cloth Line or Cord and Clips

This is a simple rope or cord made of galvanised iron, plastic, hemp or coconut fibres etc. It is tied at the two ends. The air as it moves across the clothes, draws away the cloth moisture till they are dried. The cloth line should be of sufficient length



and strength to accommodate the number and weight of the wet clothes. To avoid rust-staining of clothes, clips of plastic or aluminium are widely used, but these must have strong holding capacity.

5.3.6.1 Indoor Drying Aids

Several drying aids are particularly developed and are in use for indoor area, like flats and also when it is raining. One of these is a “wooden rack with rope and pulley” arrangement. The wooden rack has many horizontal wooden bars on which the wet clothes are spread. Therefore, it is pulled to the roof level with the help of a rope passing over a pulley fixed to roof.

In addition, many types of folding racks are used for drying purpose. A rack consists of a three-legged iron stand with a central vertical rod projective upward. To a disc attached at the top end of the vertical rod. The clothes are spread on these horizontal rods and the racks positioned at a cross-ventilating place till they are dried. The folding rack can be folded with a straight bar shape for accommodation in a corner of the room. Many horizontal bars can also be fitted to the wall at a ventilated place, one above the other, for drying of clothes. Similarly, these may be fixed to a vertical stand, at different heights. These racks can be of wood, aluminium or a chrome plated metal and may take any shape available for drying.

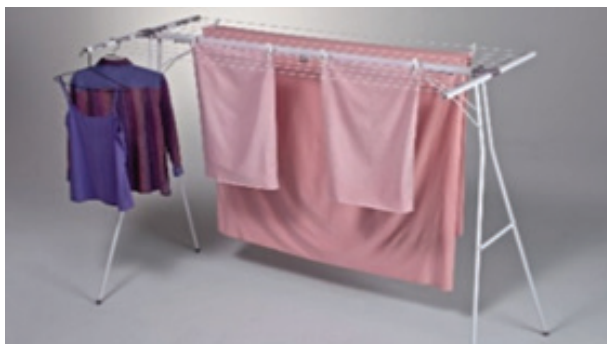

Figure 5.18 Indoor Drying Aids

5.4 Ironing Equipments

These are used to remove wrinkles and to give a better finish to the washed clothing's. Ironing clothes is really a delicate process. Poor ironing procedure leads to damaged clothing.



Figure 5.19 Iron Box

5.4.1 Irons

Iron is also known as ‘flat iron’, it is used to remove wrinkles in the fabrics. Several types are available, such as dry iron, steam and dry iron, spray-steam and dry iron. The dry irons are useful for synthetic fabrics, but to use the same the natural fabrics require pre-dampening by sprinkling of water. This wastes both time and energy of the user. Steam and dry irons have a water chamber in which a small quantity of water is heated to provide a continuous generation of steam through holes in the soles-plate. ‘Spray, steam and dry’ models also have one extra control to supply a wet spray or mist at the front of the iron.

The sole plate is smooth and made of rust-resistant aluminium alloys or stainless or chrome-plated steel. The heating units of irons have a single element mounted above or in the sole plate. This is either a nichrome ribbon wrapped around mica sheets or a tubular type element. Standard size domestic irons are rated between 750 to 1200 watts, 220 volts AC only. These are thermostatically controlled to give different

temperatures of the sole plate. Setting dial is generally marked with the nature of fabric to set temperature.

Most Appropriate Sole Plate Temperature for Ironing of different Fabric

Fabric	Temperature Range
Linen	191 – 218°C
Cotton	163 – 191°C
Rayon	135 – 163°C
Wool	Below 135°C

Care and Precautions

- Always unplug the iron after use.
- When not in use, it should be positioned on the heel rest. The cord should be wound loosely around the handle.
- Use only distilled water in the water chamber of 'steam and dry irons'.
- Do not use steam iron for dry materials which require pre-dampening. Fabric laundered with starch, most linens, heavy cottons and some medium and heavy weight linen require pre-dampening.
- Do not operate the control knobs unnecessarily.
- Spray-nozzle must be cleaned only according to the manufacturer's instruction.

5.4.2 Ironing Board and Sleeve Board

These facilitate ironing of clothing. The ironing board is a horizontal flat board. It is supported on crossed leg frame. The board is padded with flannel it is covered with white cotton or linen cover which is stretched and smooth while ironing. This is generally made of wood but may also be of aluminium or other metal. On one end of the board is a

square or rectangular area with an asbestos sheet base. This is used to place iron when hot during ironing. The ironing boards are collapsible and easy to be moved. It requires a very limited space for storage. These are very useful for ironing of skirts with numerous gathers. It is also known as "Skirt-boards". Similarly, "Sleeve-board" is useful for ironing of coat sleeves. These also have padded surface similar to that of ironing boards, but is smaller in size. The board has one open end and is supported on the solid wooden platform through vertical support.



Figure 5.20 Ironing Board



What does starch do to clothes?

For aesthetic purposes, starch is commonly used when dry cleaning clothes to leave them feeling and looking crisp, somewhat stiff, and free of any wrinkles. Starch protects the fabric from stains by sealing the individual clothing fibres. It can also protect clothes that can't be washed with water. It extends the length of the time between dry clean visits. Typically, someone can wear an article of clothing two or three times before needing it to be dry cleaned again.



5.5 Storage of Clothes

Clothes require care not only during their use but also while they are stored. The weather is not the same all the year round; hence there is a need for specific fabric storage. If large number of clothes is there a small room or store can be used for the purpose. Otherwise, a cupboard or a shelf can also be used. A good storage space should have certain desirable features :



Figure 5.21 Storage Clothes

- It should be well lighted and not very dark.
- The shelves should be in plenty and smooth. These should not be too high because it becomes difficult to store the clothes.
- The shelves should be deep.
- They should be covered with paper.
- Drawers can also be used to store clothes and are safer as compared to shelves.
- If a cupboard is used, the door should be properly closed.
- The storage space should be dry, insect free and away from dust and dirt.

5.5.1 Considerations or Steps While Storing

- The clothes should be dust free. They should be brushed. Pocket should be emptied out and should be exposed to sun before storing.
- The garments should be washed before storing.
- Clothes should not be kept in damp condition. Moisture causes mildew which may damage the clothes.
- To prevent damage from insect, moths etc. repellents such as tobacco, dried neem leaves can be used in the storage. Naphthalene balls and odonil etc. are quite effective. Even camphor is considered to be useful.
- New white cloth should be wrapped up so as to avoid yellowing, if they are to be stored for long time.
- If clothes are to be stored for long time, one must keep changing their folds as some clothes can crack at folds.
- Starched clothes should not be stored for a long time.
- Mending of all tears should be done before storing to prevent tears from becoming larger.

5.6 SUMMARY

The clothing for different age group should be selected with much care. The garments should be comfortable to wear, ease of movement and easy to care. All clothing's need proper care in order to maintain their lustre, texture, shape, appearance and strength. The life of fabric increases with proper care.

POINTS TO REMEMBER

- Income affects the selection of clothing.
- Fabric softener is used to prevent static cling and make fabric softer.
- Starch is most commonly and widely used stiffening agent.
- Bluing is done as the last rinse of the fabric after washing.
- The garments should be washed before storing.
- The clothing for different group should be selected with much care.

ACTIVITIES FOR TEACHER

- To show different types of clothing for family members.
- To arrange for a visit to know about window display.

ACTIVITIES FOR STUDENTS

- To ask students to plan clothing for family members.
- Collect pictures of clothing for different age groups.



INTERNET RESOURCES

http://www.youtube.com/watch?v=fV8BaP9iz04	Clothing care101: How to care for your clothes
http://www.youtube.com/watch?v=mDxQYYUMoWU	Clothing care 101: Tips and tricks

A-Z GLOSSARY

Ornamentation	Decorative elements added to something to enhance its appearance.
Fire Proof	Fabric which is able to withstand fire and heat.
Renovating	Restore old garments to a good state of repair and developing creative design.
Wardrobe	The total collection of articles of clothing belonging to one person
Agitation	Brisk stirring or disturbance of a liquid.
Scorching	Burning, Blistering.
Friction	The resistance that one surface or object encounters when moving over another
Solvents	The liquid which is dissolved to form a solution
Bleaching	To make fabric white or much lighter by a chemical process or by exposure to sunlight.
Fabric Softener	A liquid used when washing clothes and other laundry to soften the fabric and reduce Static

QUESTIONS AND ANSWERS

PART – I

Objective Questions

1. Which fabric is worn during cold climate?
 - a) Woollen
 - b) Cotton
 - c) Knit Fabric
 - d) Non-woven
2. A maternity wear is made of
 - a) Cotton
 - b) Lycra
 - c) Nylon
 - d) Rayon
3. Infant's clothes should be selected with basis of
 - a) Growth
 - b) Comfort
 - c) hygienic
 - d) Soft
4. Hand friction is more suitable for
 - a) Linen
 - b) Rayon
 - c) Silk
 - d) Polyester
5. The most suitable clothing for infants

a) Wool	b) Cotton
c) Bamboo	d) Linen
6. The stiffening agent is

a) Washing	b) Softener
c) Storing	d) Starch



PART – II

Answer in Three (Or) Four Points

1. State the functions of clothing.
2. List any two factors affecting clothing selection.
3. Explain the types of clothing for middle age.
4. Write a note on clothing for elders.
5. What is fabric softener?
6. Describe the types of starch.

PART – III

Answer in a Paragraph

1. Discuss the factors affecting clothing selection.
2. Write a note on clothing for infant.
3. Brief note on fabric softening method.
4. Classify starch.
5. What are the steps to be considered while storing clothes?

PART – IV

Answer in One Page

1. Elaborate on selection of clothing for adolescents.
2. Enumerate on types of hand washing.

Answers for Objective Questions

1. (a) 2. (b) 3. (c) 4. (a) 5. (b) 6. (d)

Designing of Clothing

CHAPTER

6



LEARNING OBJECTIVES

- To understand the basic concepts of designing
- To acquire knowledge for classifying the designs
- To categorize and make out the types of designs
- To gain knowledge about the basic elements of design and apply them on specific garments
- To arrange and apply various elements of design according to the principles of design

6.1 Introduction

A design is called as the blue print or model or plan of the final end product. It is also a representation of the final object. Designing is a creative process which combines the physical qualities of a product with aesthetic considerations. Design output varies according to the designer, stylist and artist. Designers work with various factors like functionality, aesthetics long range identity, cultural, political and ethical relations.

6.2 Design

Design is the arrangement of elements namely line, shape, form, colour and texture according to the principles of design namely harmony, rhythm, emphasis, balance and proportion. When it is done so, the resultant design would be beautiful and pleasing.

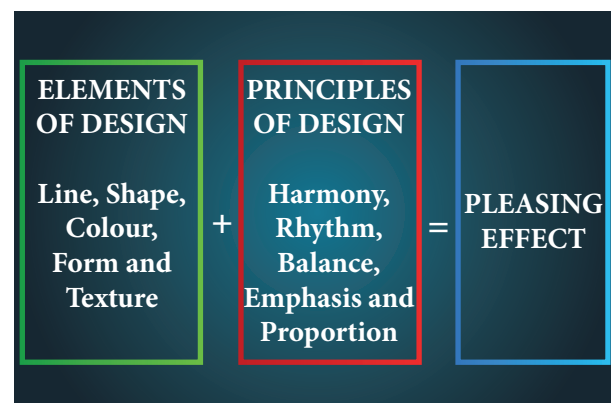

Figure 6.1 Concept of Creating pleasing Design

6.3 Classification of Design

The design is classified into two as Structural design and Decorative design. The decorative design may be divided into five type's namely naturalistic, conventional, abstract, historic and geometric designs.

6.3.1 Structural Design

The structure of an object is an integral part of the design and is said to be structural design. As far as the textiles are concerned, the woven pattern itself is the structural design. The garment details such as yokes, collars, pockets, sleeves as well as the seam lines are the structural design. The structural designs should meet basic criteria and should serve the purpose, be simple in design, appear perfect in proportion and have good choice of material.

Structural design can be classified into two types as good structural design and bad structural design.

To create any garment with good structural design, there are some criteria to be fulfilled. They are:

- the silhouette should match the body structure
- provide comfort to the wearer
- line, form and texture should merge with the body structure.

When the above criteria are not fulfilled the garment is said to have bad structural design.

DO YOU KNOW? How does the design on the fabric show an effect in your body shape?

Small designs on the fabric or outfit are more suitable for stout figures as it makes you look lean



6.3.2 Decorative Design

Decorative design is the surface enrichment on any fabric or a garment. It is applied on structural design for the purpose of adding a richer appearance. When design is imparted after weaving, it becomes decorative design.

Examples - applique, patch work, embroidery, painting or any trimmings or decoration.

Good decorative design should be :

- moderate and simple
- placed in a structural point (collar, seam line, pocket, sleeve and yoke)
- shape enhancing
- suitable for the material and garment style
- emphasized with enough background space
- uniform in distribution of pattern



Structural design Decorative Design

Figure 6.2 Design Classification

6.4 Types Of Decorative Design

There are 5 types of decorative design. They are :

1. Naturalistic
2. Conventional
3. Abstract
4. Historic
5. Geometric

6.4.1 Naturalistic Design

When objects from nature are used as such, it is known as naturalistic design. The designs can be selected and reproduced exactly. Examples: Flowers, leaves, animals and landscape. The inspirations for design selection vary from designer to designer, time to time and place to place. The inspired designs from nature can be applied on textiles and garments in the form of silhouettes, print patterns, textures and colours. The selection of the design varies depending on various factors such as age, sex, body structure, occasions, and purpose. It depends on the preference, mood and interest of a designer.

Example - Sunrise, trees and forest.



Figure 6.3 Naturalistic Design

6.4.2 Conventional Design

When an object from nature is adopted to suit the purpose of the object and be decorative, the motif ceases to be naturalistic.

E.g. Fruits – Mango, flowers - hibiscus and animals or birds – Peacock.



Figure 6.4 Conventional Design

6.4.3 Abstract Design

Motif which does not have nature as a source but the combination of lines producing irregular form. These designs are not easily recognized. The modern art is an abstract design.

Examples: Wavy designs, ripples, designs with lines etc.

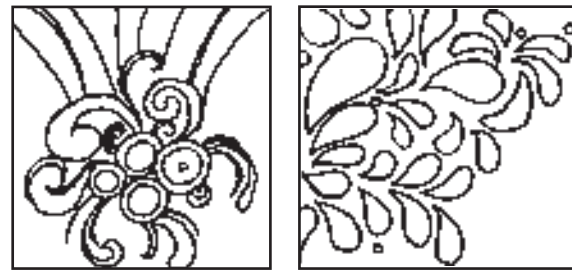

Figure 6.5 Abstract Design

6.4.4 Historic Design

It refers to the designs depicting famous monuments or building of historic importance.

Examples: Temple, Taj Mahal.

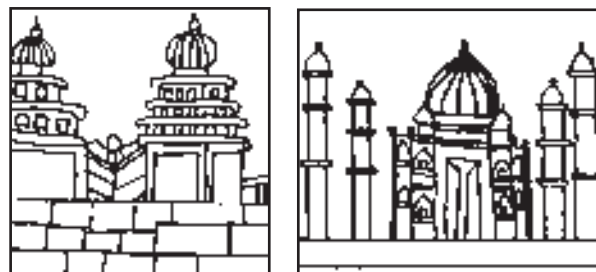

Figure 6.6 Historic Design

6.4.5 Geometric Design

It is not derived from nature. It is derived from geometric patterns such as circles, rectangle, triangle, parallel lines and so on.

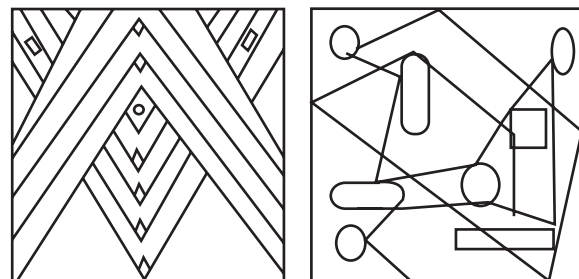

Figure 6.7 Geometric Design

6.5 Elements of Design

The elements are the fundamentals of a design. These form the basic structure of a design conveying wide range of messages. It is very important for a designer to understand design elements as it finds its application in various fields like interior decoration, fashion designing, architecture, vegetable carving and visual arts. The basic elements of design are line, shape, form, colour and texture.

6.5.1 Line

Line is defined as an indication that gives a distance between two points. It is one of the most basic elements in art and design. Line is a mark made by the media such as brush, pencil, stick, pen, charcoal and paint. Lines are found everywhere as these are used in forming words, numbers and symbols. Line exists in nature as a structural feature. For example, lines on zebra, branch of a tree, mountain peaks, weaves and thunder (Figure 6.8).



Figure 6.8 Lines in Nature

It also defines mass and volume. It may be continuous or discontinuous.

DO YOU KNOW? What types of designs are suitable for tall figures?

As the horizontal lines on garments bring an optimal illusion that the figure is shorter, a tall person can go for these lines.



6.5.1.1 Types of Lines

The lines may be classified based on the curves introduced or continuity. (Figure 6.9 and Table 6.1)

a) Based on Curves

A Straight Lines

These lines are very rigid, structural and formal in nature. They depict masculinity in designs. Straight lines are forceful leading the eye to the focal point. Example: Landscape designs (coconut trees). These are more suitable for male garments.

B. Curved Lines

These are more pleasing to the eyes. These are soft and depict femininity in designs. Curved lines are informal, and relaxed in nature. These are more suitable for female garments.

C. Zigzag Lines

A zigzag line is an angular shape characterized by sharp turns in alternating directions. These lines have short sharp turns and angles. It is said to be a tracing a path between two parallel lines.

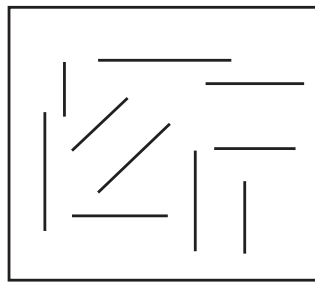

A. Straight Lines

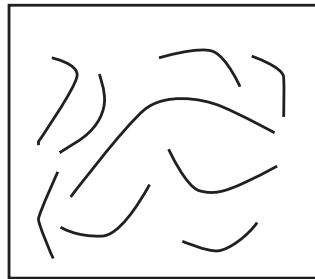

B. Curved Lines

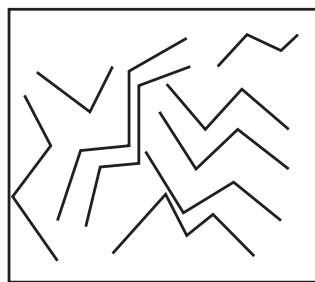

C. Zig Zag Lines

Figure 6.9 Types of Lines

All these types of lines may be continuous or discontinuous.

b) Based on Continuity

Lines are divided into two based on its continuity as continuous and discontinuous lines (Figure 6.10).

1. Continuous Lines

When the lines are drawn continuously these are called continuous lines.

2. Discontinuous Lines

These lines are broken and drawn without continuity.

Line Type	Continuous Lines	Discontinuous Lines
Straight		
Curved		
Zig Zag		

Figure 6.10 Lines - Based on Continuity

c) Based on Direction

The lines may be either in the silhouette or in the decoration of a garment. The lines are applied on the garments as given below (Figure 6.11).

● Horizontal Lines

The horizontal lines suggest a feeling of restful, relaxing and almost peaceful response. These lines move width wise on an object. These lines have a tendency of creating illusions as if the garment is shorter and larger.

● Vertical Lines

These lines run erect from up to down on a garment. These lines give an illusion as if the garment is taller and narrower. These create a sense of stability.

● Diagonal Lines

These lines are neither horizontal nor vertical but run in a diagonal manner with an angle. These lines suggest a feeling of movement or direction. These lines give an illusion of more depth and space. On garments diagonal lines should be combined with



Figure 6.11 Lines Based on Direction

vertical or horizontal lines for better effect. But if they are used alone for the entire garment, it gives a disturbing effect.

● Parallel Lines

These lines in the design run along each other with equal distance in between them.

● Perpendicular Lines

These lines in the design run at 90 degrees to each other. One line is in vertical and the other line is in horizontal manner.

● Oblique Lines

These lines in the design run in a slanting manner.

● Radial Lines

These lines in the design run in a circular manner.

● Jagged lines

Jagged lines are not in order and these give a feeling of anger and disorder.

d) Based on the Measure

They are thick, thin, short, long, tapering and uneven. The lines are drawn with various depths as required to complete a figure. Few examples for the measure variations are given below on a garment (Figure 6.12).

a. Thick – This line in the design is fat and bold.

b. Thin – This line is thin forming the design.

c. Short – This line in the design is short.

d. Long – This line is very long in the design.

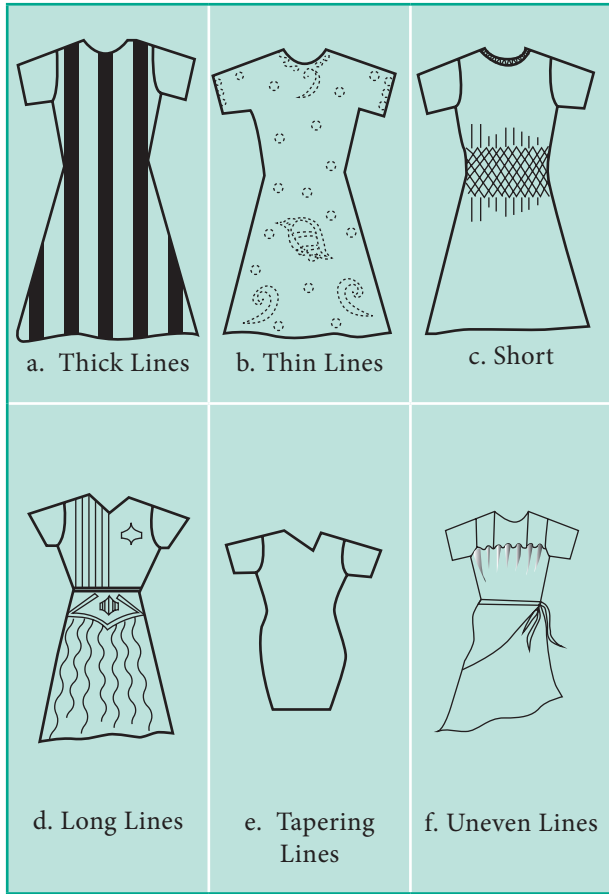

Figure 6.12 Based on the Measure

e. Tapering – This type of line tapers towards the end. The initial portion is broader and it narrows towards the end.

f. Uneven – This line is uneven throughout the design. It is quite disturbing.

e) Based on the Character- sharp, blurry, fuzzy, choppy, graceful and smooth. (Figure 6.13).

a. Sharp – The lines are pointed.

b. Blurry – The lines are blurred and unclear.

c. Fuzzy – The lines are hairy and blurry.

d. Graceful – The lines are elegant and stylish.

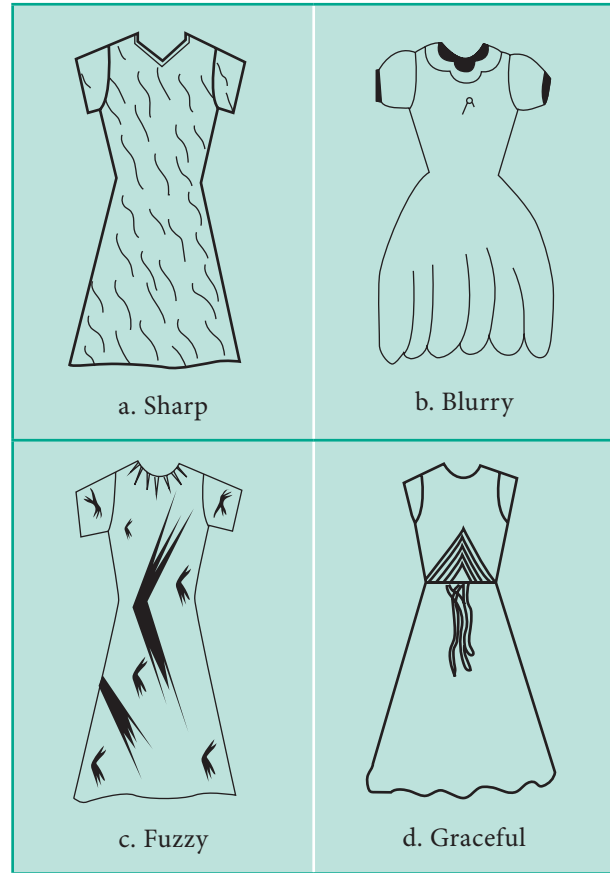

Figure 6.13 Based on the Character

Table 6.1 Types of Lines Based on Different Aspects

S.No	Particulars	Types
a)	Based on Curves	Straight lines Curved lines Zigzag lines
b)	Based on Continuity	Continuous lines Discontinuous lines
c)	Based on Direction	Horizontal lines Vertical lines Diagonal lines Parallel Perpendicular Oblique Radial Jagged
d)	Based on the Measure	Thick, Thin, Short, Long, Tapering Uneven
e)	Based on the Character	Sharp, Blurry, Fuzzy, Graceful

6.5.2 Shape and Form

Shape

A specific configuration of the line or plane in 2-dimension is defined as shape, that separates a form from the background space. Shapes of clothing determine the outer shape of a person, as shape describes the outer dimensions of an object. The silhouette creates an impression about the person. The shape in a garment is either structural or decorative in nature. The shapes of garment may be modified in different ways. The shapes are introduced in garment through features such as bodice, skirt, sleeve, collar and yoke. When lines are joined to enclose space, they result in an outline joined to enclose a contour or shape. The garment shapes which could be applied for enhancing the comfort and beauty are expressed under.

6.5.2.1 Geometric Shapes

The 3 distinct types of geometric shapes are **rectilinear** – square or rectangle, **angular** – triangle or pyramid and **curvilinear** – circle, sphere cone and cylinder. Geometric shapes are structured and often symmetrical. Rectangle, trapezoids and parallelograms are modified squares. An oval shape is an elongated circle and pentagons, octagons and hexagons are created with a combination of rectangles and triangles. (Figure 6.14).

- **Rectangle**

Opposite sides of this shape are equal. Styles with these lines are slenderizing and suitable for the well proportioned, heavier women. It is influenced by three factors namely shape, size and position. The examples for a rectangular shape are

garments with long, straight, hanging in loose, graceful folds.

- **Triangle**

Triangular shape is three sided. It may be formed also in an inverted position in the garments. It contributes unity and balance to the garments as it is stable. Examples are garments with wide shoulders, narrow skirt, dolman or raglan sleeves are good fashion design styles for large bust.

- **Square**

A square has all sides equal. It gives visual clarity due to its regularity. Examples are garments with straight or boat shaped neckline, boxy jackets and capes. Generally this style is very good for the very thin figured women, however, with proportions well planned and good design fabric can camouflage various figure irregularities.

- **Round**

The round shapes are suitable for formal wear or afternoon frocks. This design in fashion garments is the most attractive on the very young and the very thin figure. Examples for this shape are wide, crinoline lined skirts, petal shapes and puffed sleeves.

- **Hourglass**

Hourglass shape is natural and gives smooth fit over hips and full skirt at bottom. It also gives a very good appearance for the tall, thin figure. Examples: wide shoulders and leg of mutton sleeves.

- **Oval**

This shape is good for well proportioned, ideal figure. It is suitable especially for afternoon and evening wears.

Examples: draped and softly molded, very feminine and decorative garments.

● Circles

This shape is useful and compact. It represents unity, continuity and economy.

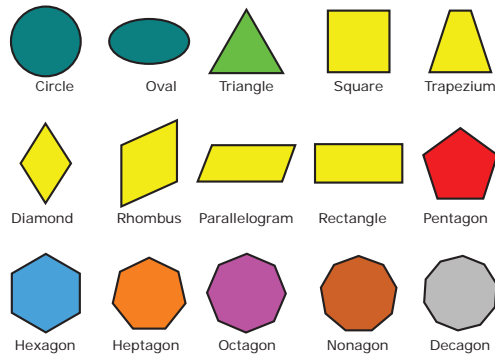

Figure 6.14 Geometric Shapes

6.5.2.2 Natural Shapes

Natural shapes are shapes that are found in nature, and some shapes are made by man also. Some examples of natural shapes are leaves and puddles.

6.5.2.3 Abstract Shapes

Abstract shapes are those which are identifiable and are not real in the same way that natural shapes are, Example; A stick – figure drawing of an animal, alphabet graphs, icons and symbols can express an abstract shape (Figure 6.14).

6.5 Form

Form is three dimensional. Examples are sphere, cube, cone etc. (Figure 6.15).

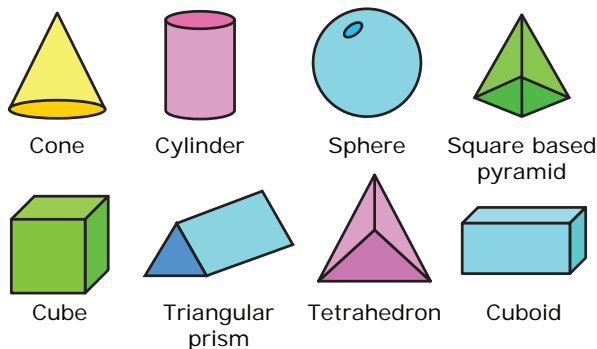

Figure 6.15 Form

6.5.3 Colour

Colour is produced when light strikes on an object and reflects back in your eyes. It stirs enthusiasm. There are three properties of colour. They are:

6.5.3.1 Hue

Hue is the name of a colour. Examples – red, yellow and blue. The warm hues are known as advancing colours as they create illusion of moving forward. These also emphasize the body size contours. There are many theories, to explain the role of colours. Some of the common colour theories were devised by Munsell, Ostwal, Rood and Prang. The widely used theories are Munsell colour systems and the Prang colour systems. Hue may be warm or cool. (Figure 6.16 and Table 6.2).



How does the selection of the colour alter the appearance of the wearer?

The colour more suitable for thin figures – Lighter tones than darker tones. So a thin figure can select lighter tones and stout figure can choose a darker tone.



Prang Colour System

This was developed by David Breweser based on three primary colours.

Table 6.2 Warm and Cool Colours	
Warm Colours	Cool Colours
<ul style="list-style-type: none"> Colours that on the red side are termed as warm hues Warm hues are red, yellow and orange. Red and Orange are the warmest of the colours. Warm colours are cheerful, exciting if in large proportions These make the area appear larger and closer than others colours 	<ul style="list-style-type: none"> Colours that the near the blues are termed as cool colours Cool hues are found in water and sky which are green, blue and violet. Blue and blue violet are the coldest hues Cool colours are restful Cool colours make objects, shapes or areas appear smaller and it minimizes body size and shape
<p>Green is between heat and cold but gets warmer nearer the yellow zone and cooler near the blue zone.</p>	

a) Primary Colours

The colours such as red (R) yellow (Y) and blue (B) are the fundamental colours as they cannot be obtained by mixing any other colours. All other colours are obtained by mixing these three colours.

b) Secondary / Binary Colours

When two primary colours are mixed in equal amounts a different hue is obtained. This new hue is called binary/secondary colour. They are purple (P) (R+B), Green (G) (Y+B) and Orange (O) (R+Y) (Table 6.3).

Table 6.3 Secondary / Binary Colours	
Primary colours	Secondary Colours
Yellow + Red	Orange
Red + Blue	Purple/Violet
Blue + Yellow	Green

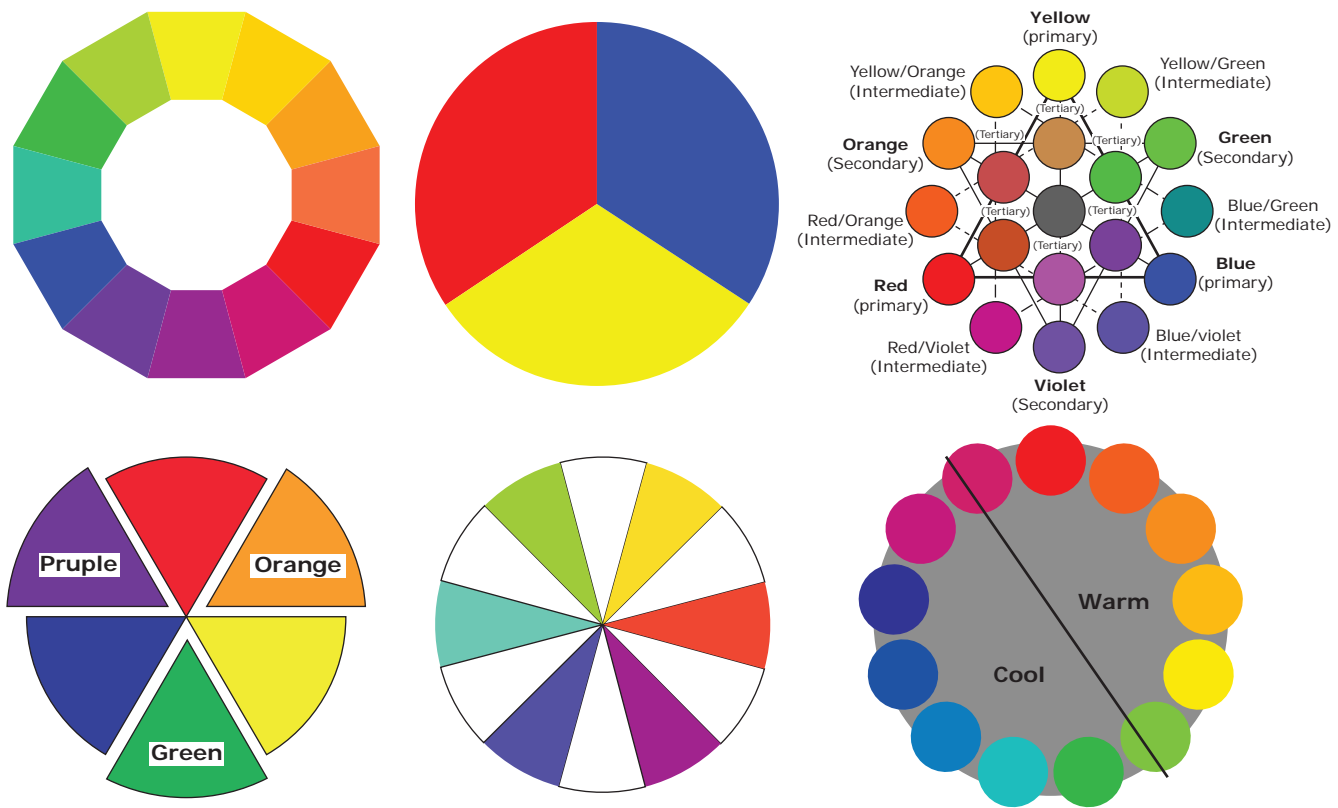

Figure 6.16 Colours and its Types

c. Intermediate Colours

It is made by mixing a primary with its adjoining secondary colour. These are called standard colours (Table 6.4).

Table 6.4 Intermediate Colours

Primary colours	Secondary Colours	Intermediate colours
Yellow +	Green	Yellow Green
Red +	Purple	Red Purple
Green +	Blue	Green Blue
Red +	Orange	Red Orange
Blue +	Purple	Blue Purple
Yellow +	Orange	Yellow Orange

d. Tertiary Colours

It is a combination of two binary colours. The resulting colour is a tertiary colour. (Table 6.5)

Table 6.5 Tertiary Colours

Secondary colours	Tertiary colour
Orange + Green	Tertiary yellow (TY)
Purple + Orange	Tertiary red (TR)
Green + Purple	Tertiary blue (TB)

e. Quaternary Colour

It is obtained by mixing two tertiary colours. (Table 6.6)

Table 6.6 Quaternary colour

Tertiary colours	
Tertiary yellow + Tertiary red	Quaternary orange (QO)
Tertiary red + Tertiary blue	Quaternary Purple (QP)
Tertiary blue + Tertiary yellow	Quaternary Green (QG)

6.5.3.2 Value

It gives the lightness or darkness of a colour. To change the value of colour, white or black must be added. The value of any colour gradually changes with the highest at the top and darkest at the bottom.

Tints and Shades

A value that is lighter than the normal colour is called a tint and the one that is darker than the normal is called a shade.

Values are changed by adding white or water to lighten them and by adding more pigment or black to darken them. (Figures 6.17 and 6.18)



Figure 6.17 Tints



Figure 6.18 Shades

6.5.3.3 Intensity or Chroma

It shows purity and strength of colour. The brightness or dullness of a colour denotes the strength and weakness of a colour. **Example** – bright red or dull red.

Intensity or chroma describe the degree of saturation of a colour, chroma and intensity are interchangeable. High chroma are pure, strong, brilliant saturated colours while low chroma colours are muted, weak grayed and dull. Bright, strong, high- chroma colours are conspicuous and make the body of the wearer appear larger. (Figure 6.19)



Figure 6.19 Intensity

6.5.4 Texture

It is tactile which refers to the surface quality and is assessed through feel of a fabric. The fabric is said to be smooth, rough, soft or hard to touch. Visual texture is the illusion of 3 dimension surface. Imagine running hand on denim

or satin fabric. The denim fabric gives a rough texture where as a satin gives a soft and smooth texture. The rough texture absorbs more light and smooth surface reflects light. (Figure 6.20)

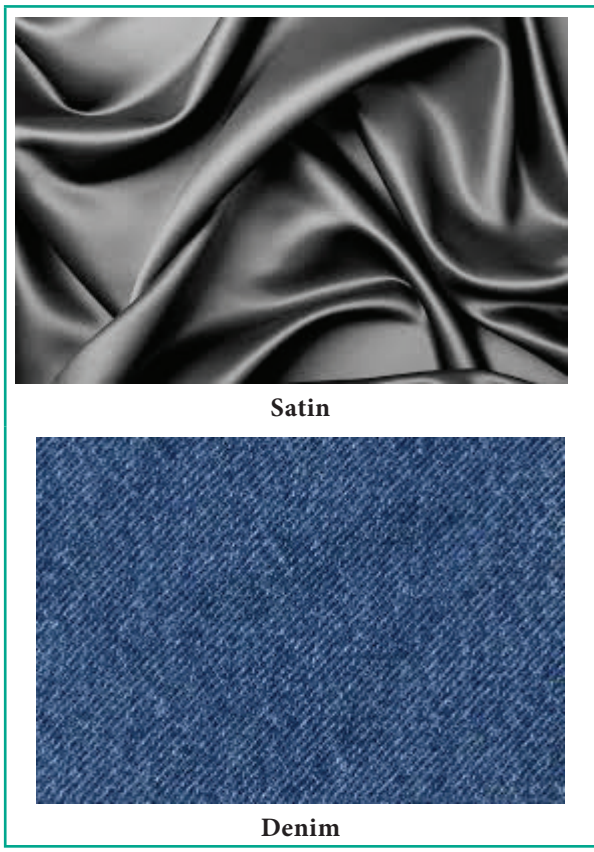

Figure 6.20 Texture

6.6 Principles of Design in Clothing

The principles of design refer to the organization of a work of art. The principles of designs are said to be yard sticks as these help us to assess a design. These assist a designer which textile or garment to create and enhance in a very pleasing, attractive and effective manner. The principles of design are as follows.

- Harmony
- Balance



- Emphasis
- Proportion
- Rhythm

6.6.1 Harmony

Harmony means unity. It is very much essential and fundamental while creating a design. It results from a combination of related elements in art. Using related and repeated elements of art this is obtained. Harmony is an art principle that expresses unity through selected and arranged consistent objects.

6.6.1.1 Harmony of Line

When a set of lines are drawn within a corner following the lines of the corner, **repetition** occurs.

When a horizontal and vertical line come together in a right angle or a corner, these lines are in opposition to each other and form **contrast**.

Any line that cuts across a corner from one opposition line to another is a **transitional** line, but when a straight line drawn across a corner is so sudden and sharp that it cuts off corner harshly is called **contradiction** (Figure 6.21).

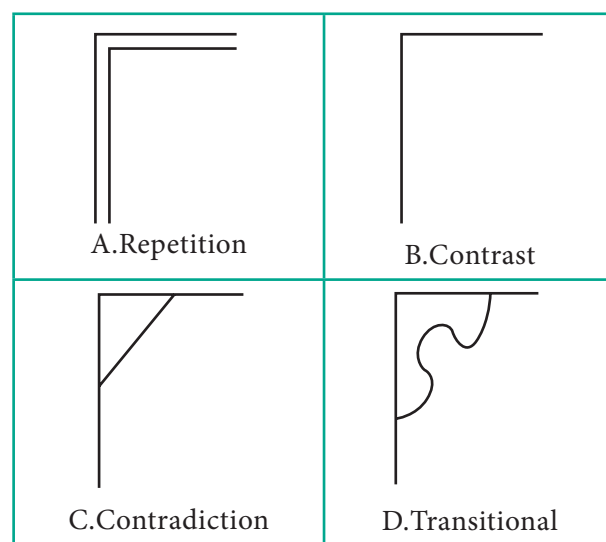

Figure 6.21 Harmony of Line

6.6.1.2 Harmony of Shape

A combination of lines results in shapes. Transitional lines have a graceful, softening effect and have the power to bring together shapes which might in themselves be inharmonious.

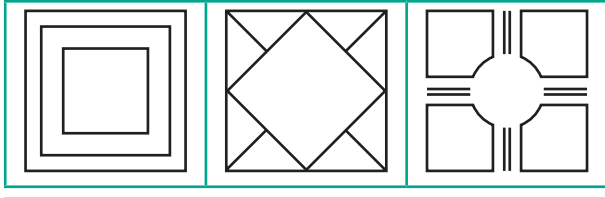

Figure 6.22 Harmony of Shape

6.6.1.3 Harmony of Texture

Textural surface ranges from smooth to rough. An example of poor texture combination sometimes seen in the shops is cane furniture upholstered in lustrous rayon. These textures are entirely unsuited to each other. Harmony in texture is brought in a garment by combining satin with lace or netted materials.

6.6.1.4 Harmony of Ideas

It is not enough that sizes, shapes, colours and textures should have something in common, but there must be harmony in the ideas presented together. For example, an apron and hood may have motifs of a cup and saucer.

6.6.1.5 Harmony in Colour

Colour schemes are like musical chords, structuring colour groups according to certain visual relationships among their attributes of hue, value and intensity. The guidelines for creating colour harmonies are

Warm colours should be combined with warm colour and cool colour with cool ones.

Colour harmonies are divided as expressed in Figure 6.23.

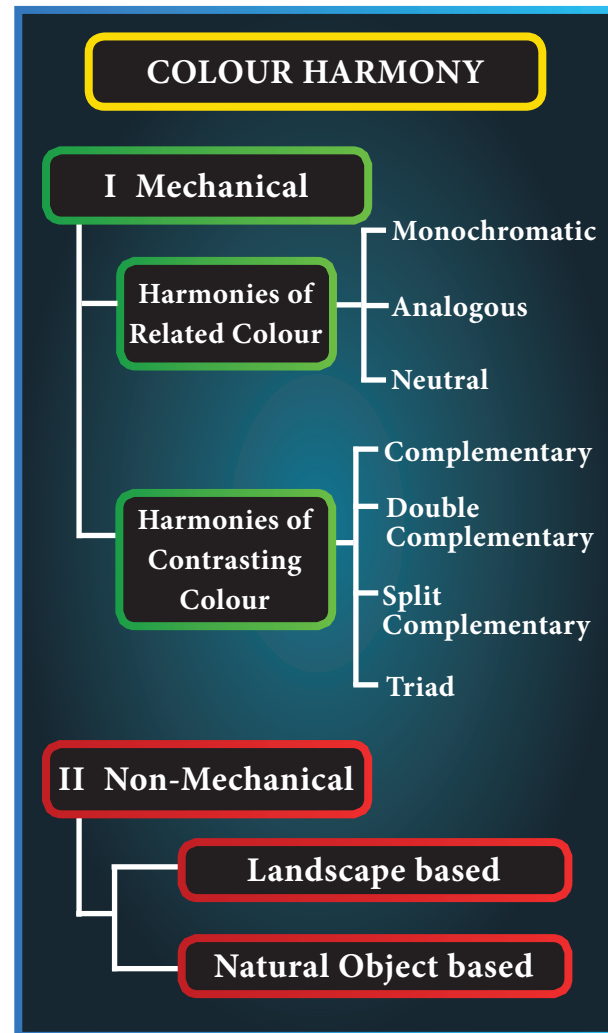

Figure 6.23 Divisions of Colour Harmonies

Colour harmonies can be created in two ways, namely, mechanical and nonmechanical. The colour harmonies under the first category are further divided as related and contrasting colour harmonies. The related colour harmonies include mono-chromatic, analogous and neutral, and these types of colour harmonies give a lot of freedom to its creator. A large number of objects with a variety of tints and shades are available in the market these days. Therefore one can successfully combine them to create 'ready-made' or non-mechanical colour harmonies. Non-mechanical are nature-based and ready-made. Landscape



and other natural object based colour harmonies are included in this category.

I. Mechanical Standard Colour Scheme

These schemes are based on the Prang Colour wheel, and are the most easy to use. The mechanical standard colour schemes / harmonies may be of two types;

- Harmonies of related colours and Harmonies of contrasting colours.

I. A) Harmonies of Related Colours

Related colour schemes are based on common hues and tend to create a restful, quiet effect as these colour combinations give the most pleasing effect and are likely to be those schemes having harmony or unity. They are based on either a single hue or a series of analogous hues, and promote harmony and unity. The related colour schemes are Monochromatic, Analogous and Neutral colour harmonies (Figure 6.24).

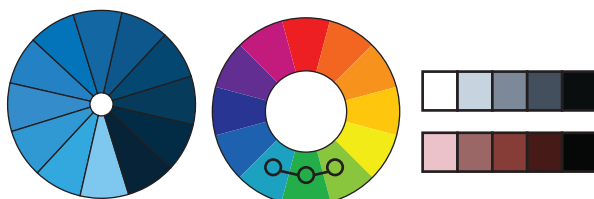

a. Monochromatic b. Analogous c. Neutral

Figure 6.24 Related Colour Harmony

I. A. i) Monochromatic Colour Scheme / One Hue Colour Harmony

Mono-chromatic scheme is the simplest of all other schemes to use, because they are based on only one hue. Monochromatic means 'of one colour'. Under this scheme only one hue is used with different values and intensities. The popular scheme of beige brown, and orange is a truly, monochromatic scheme, because the tans and browns are simply tints and shades of grayed orange. A brilliant form of orange may be used as an accent or

even for larger areas, but if any other hue is introduced here, the harmony is no longer monochromatic. Another example is that red can be used with its various intensities giving vermilion, carmine, crimson, etc. and various values in high-key giving Alps red, peach, flesh tint, Indian red, brown, burnt sienna etc. The range may vary from almost white to almost black and from very bright colours to dull colours. Black and white are neutrals that can be used to add spice and interest to the scheme. While using a monochromatic colour scheme, one can create a feeling of warmth or cold in a room.

Normally the lightest of the colour (highest value) should cover the largest area and at the highest level, the mid value of the colour at the middle and the darkest at the lower level and so on.

I. A. ii) Analogous Colour Scheme / Adjacent Colour Scheme

Analogous colour scheme is one that combines colours that are adjacent to one another in the colour wheel. In this colour scheme, colours situated next to each other on the colour wheel of a Prang colour system, are used. It generally uses one colour as its major force with the two neighbouring colours as secondary forces, Example, yellow with yellow-green and green or blue with blue-green and blue-purple. Because of their position on the colour wheel, they are often referred to as related colour schemes.

A combination of yellow, yellow orange, orange and red orange combine to make warm adjacent colour scheme. A combination of blue purple, blue, blue green and green provides a cool adjacent colour scheme. At the same time, a combination of both warm and cool colour scheme is also





possible in an adjacent colour scheme. When the adjacent colours of blue green, green, yellow green and yellow or blue purple, purple, red purple and red are combined, they provide a colour scheme which has both warm and cool colours.

I. A. iii) Neutral Colour Scheme

The neutrals are black, white and grey. A neutral colour such as beige or brown with an accent colour for breaking the monotony can be used in this colour scheme. Colour schemes built entirely around neutrals are very restful, but texture and patterns must be used to prevent the design from becoming dull, boring or monotonous. Therefore, this colour scheme should be used in limited areas or for limited periods in any dress. Black-and-white schemes are highly dramatic because of their strong contrast.

I. B Harmony of Contrasting Colours

Contrasting colour schemes are based on opposing hues and tend to be stimulating and balanced because they include both warm and cool hues. They are grouped as Complementary, Double Complementary and Triad. Two colours, which are placed extremely opposite on the colour wheel, one might be cool, and the other warm, are chosen for the colour scheme. Examples; Red and green, blue and orange, yellow and purple. (Figure 6.25)

I. B. i) Complementary Colour Scheme

It is based on two colours found opposite to each other in the colour wheel. These colours need not necessarily be used in their pure form and they can be used in many values or intensities to have variety.

A complementary colour scheme can be developed from a monochromatic colour scheme accentuated with a complementary colour or an even balance of two colours.

On a Prang the complementary colours are

- Yellow and Purple
- Red and Green
- Blue and Orange
- Yellow Green and Red Purple
- Blue Green and Red Orange
- Blue Purple and Yellow Orange

Thus, in all, they make six complementary colour schemes.

A complementary colour scheme is a stimulating, vivid and bright colour scheme. It provides a combination of both a warm and a cool colour. Their tints such as the pink and light green lack character when placed together.

I. B. ii) Double Complementary Colour Scheme or Tetrad

Four in a double complementary is called a tetrad. If a narrow 'X' is superimposed on the colour wheel, then there will be two sets of complementary colours with which to work. Two adjacent colours and their complements when used together form double complementary harmonies like the combination of – purple and red purple with yellow and yellow-green. In using a double complementary harmony, there should be an outstanding hue which should be in largest amount and be the dullest of all colour. For example, as in the case of the above example, purple can be considered to the line having these qualities. Use a brilliant form of one, like yellow, in a small area as an accent on a garment say collar or yoke. The





remaining two colours i.e., red purple and yellow green can be used in the remaining area of the garment like top and bottom.

This colour scheme is exciting, lively and sophisticated. It also provides more variety than a simple complementary colour scheme. Since this colour scheme provides a combination of both warm and cool colours, they can be successfully used in a garment whether for a stout or thin figure. Some of the examples of a double complementary colour scheme are :

- Yellow and yellow orange with purple and blue purple
- Yellow orange and orange with blue and blue purple
- Orange and red orange with blue and blue green
- Red and red purple with green and yellow green.

I. B. iii) Split Complementary Harmony

In this colour scheme, one colour is combined with the two colours on each side of its complement. One might select a hue and combine it with the colours that are on either side of its complement as though placing a narrow-angled “Y” on the colour wheel. As the term implies, one “splits” or divides the complement of a hue into its component parts, and while using these parts the complement is omitted. A true

split complementary scheme is a harmony of similar colours with a note of a contrasting colour. The amounts of the different values and intensities should be adjusted as in any other contrasting colour harmony.

This provides three colours to work with an odd number of colours combined together always yield a good effect as a colour scheme in a garment. By varying their intensities and values some interesting combinations can be worked out. Following combinations can also be worked out to prepare split complementary colour schemes.

- Yellow with blue purple and red purple
- Yellow green with purple and red
- Green with red purple and red orange
- Blue green with red and orange.

The warm hues in combination with the cool hues need careful handling because of their strong and advancing effects. When executed properly, this colour harmony would produce a pleasing effect.

I. B. iv) Triads

An equilateral triangle placed on the Prang colour wheel will point to three equi-distant colours that form the triad. Turning the triangle will point out different combinations. In the Prang Chart, there is a Primary triad – when the three primary colours fall at the tips of the triangle (red, blue and yellow) and a

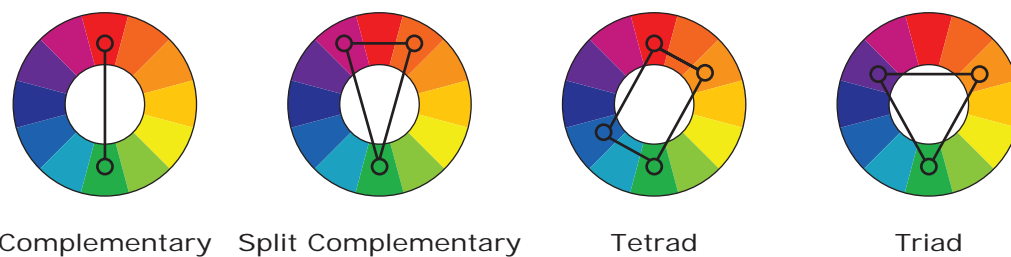

Figure 6.25 Contrast Colour Harmony





binary or secondary triad (green, orange and purple). There are two intermediate triads – yellow-orange, blue-green and red-purple while the other is yellow-green, blue-purple and red-orange.

II. Non-Mechanical

The non mechanical colours are readymade or nature based ones. The nature based colours are of two types namely Landscape-Based Colour Scheme and Nature Object-Based Colour Scheme.

II. A) Landscape-Based Colour Scheme

The colour of sea, sky, clouds, mountains, land covered with plants, trees, earth or barren land. We find that they do not have sharp colours and are large in area. The sky occupying the largest area is light blue; water in the sea / river / canal also has the reflection of the same light blue ; mountains are generally covered with either snow or light brown ; trees and plants covered with green leaves. Earth is of dull brown or ochre and trees are green.

II. B) Natural Object-Based Colour Scheme

We observe a butterfly, or a fish, or a flower that give the hue to a colour scheme. A butterfly might give a colour scheme of lemon / golden yellow, brown, black and white. Or a flower might lead to a colour scheme of lilac and white accentuated with violet and green.

6.6.2 Proportion

The word “proportion” means one part in relation to another. Proportion is defined as the relation between parts of the same thing or between different things of the same kind. The principle of proportion is

sometimes called the “**law of relationship**”. It deals with relationship in size, shape, colour, texture and pattern. Greeks, after centuries of striving for beauty, arrived at a point where nearly everything they made exhibited good spacing. The oblong which they used as a basis of their space divisions is called the “**golden oblong**” and is a recognized standard for space relationships. This Greek oblong measured approximately two units on the short side and three on the long. While the ratio of about 2:3 or 3:5 is the relationships used by the Greeks for their flat surfaces, their standard for solids is a ratio of about 5:7:11.

6.6.2.1 Division of Space

One of the most important problems faced by the designer is that of organizing the total areas into five space relations. (Figure 6.26)

	Division of Space
	Space and Lines A – Lines or spaces between them are not repeated. B – All lines and spaces are alike. C- Spaces differ from lines. D – Spaces are different from the lines and from each other.
	The Greek oblong is a standard of good proportion. The sides are in the relation of two parts to three. It is called Golden Mean of Golden Rectangle.
	These two squares of same size show increased height when eye travels up and down. When eye travels side to side the square tends to show a decrease in height.

Figure 6.26 Division of Space



6.6.2.2 Creating Optical Illusions

A change in appearance of an area by means of proportion might involve the lengthening or broadening effects of vertical and horizontal lines. Lines running in a vertical direction tend to slenderize and make an object appear taller, whereas lines running in a horizontal direction would make an object appear shorter and broader. (Figure 6.27)

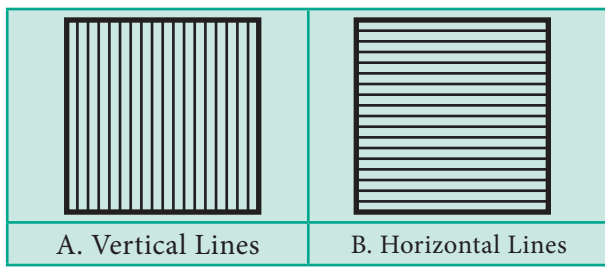

Figure 6.27 Optical illusions

6.6.2.3 Scale

The third aspect of proportions is called scale. It is the capacity to select designs and arrange them so that they look well together. The design principles of scale is related to proportion. Both proportion and scale deal with the relative's sizes of things. Proportion pertains to the relationship between the parts of a composition and scale refers specially to the size of something, relative to some known standard or recognized constant. Scale, in this sense means,

that the size of all the elements making up the structure have a consistent, pleasing relationship to the structure and to each other, and that the size of the structure is in good proportion to the different objects combined with it.

A very small object will never look so small as when it is placed near a very large one. That is because the two sizes are not consistent. In a consistent scale, it is possible to create illusion that causes

astonishment when the actual sizes of objects are realized.

Proportion in Colour

This principle applies to colour as much as to sizes. Colour combinations are more beautiful when the amounts are varied, than when they are equal. Proportion holds good here but if the colours are very different in their forcefulness, they should be arranged according to the "Law of Areas", and the brighter colours used in smaller amounts.

6.6.3 Rhythm

Rhythm is a very important art principle. According to Beitler and Lockhart, 'a sense of order, a quality of gracefulness, a feeling of easy movement' – all lead to a principle of design; which is called as "rhythm".

Rhythm is related movement or the sense of leading the eye from one part of a design to another in an easy, flowing manner. Rhythm is organized movement in continuity. It occurs in regular, repeated movement and also in variable transitional movement.

Rhythm may be defined as a form of movement. But not all movement in design is rhythmic. Rhythm means an easy, connected path, along which the eye may travel in any arrangement of lines, forms or colours. Rhythmic movements can be achieved through repetition of shapes, progression of sizes, continuous line movement, radiation and gradation

6.6.3a. Rhythm through Repetition

A feeling of rhythm may be expressed by repetition of lines, colours and shapes. When a shape is regularly repeated at



proper intervals, a movement is created which carries the eye from one unit to the next in such a way that one is not conscious of separate units, but of a rhythmic advancement making it easy for the eye to pass along the entire length of the space. While doing so one must also keep in mind the principles of proportion that deal with the same spacing between each, would give us an example of repetition so to avoid monotony in spacing, good proportion is a necessary accompaniment. Stitching rows of braids, or pleats or tucks on a dress, placing groups of buttons, repeating dots, circles, squares or any shape of spot in embroidery brings a nice rhythm in a garment (Figure 6.29).

may give variety says Beitler. Change in amounts overlapped in a composition, change in texture from smooth to rough, shiny to dull etc. (Figure 6.30).

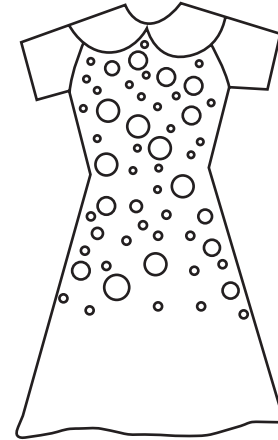

Figure 6.29 Rhythm through Progression



Figure 6.28 Rhythm through Repetition

6.6.3c. Rhythm through Continuous Line Movement

6.6.3b. Rhythm through Progression of Sizes and Gradation

Rhythm is brought through a progression of sizes. A regular progression of sizes may be satisfying enough for scallops on lace and embroidery; one enjoys a more varied, progression when large objects are involved. Progressing sizes create a rapid movement of the eye, and they are often badly used. A gradual change in the length or thickness of lines

This enlargement of the spiral of a shell brings out the beauty in the sequence of its line movement and in the rhythmical gradations of its spaces. In some designs it is not evident that any element is repeated or that there is a progressive change from one part of the design to another and yet we have a sense of easy movement throughout the design. The related movement may be literally having breaks in the line but spaces that are small enough so the eye still moves over to the next section of the line in the rhythmical manner.

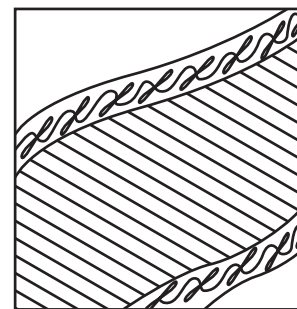

Figure 6.30 Rhythm through Continuous Line Movement



6.6.3d. Rhythm through Radiation

Radiation is a method of obtaining organized movement. It is a type of movement that grows out of a central point or axis. Radiation means lines or parts of a design growing out of or an extending from a line or a point. The designs should be kept or arranged in such a way that the eye travels from one corner to the other corner of that particular area of a dress easily or rhythmically. Restful effect can be gained through proper placing of all these decorative things. Rhythm plays an important role in window display, and advertising too. (Figure 6.31).

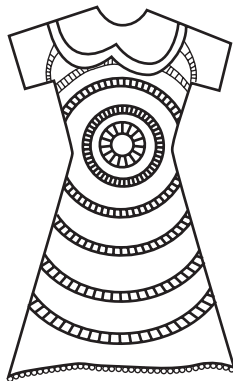

Figure 6.31 Rhythm through Radiation

6.6.3e. Rhythm through Alternation

Rhythm is brought through alternation of shape, line, form or texture. The eye is taken in a direction through alternation of the motifs in a design. (Figure 6.32).

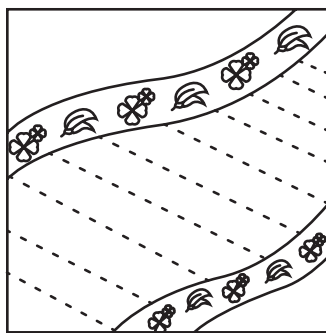

Figure 6.32 Rhythm through Alternation

6.6.3f. Rhythm in colour

In colour, rhythm and balance through crossing or repetition implies an arrangement of colours along which the eye can move easily from one colour to another. Rhythmic colour results for the use of gradations in hue, value or intensity. Gradation is a sequence in which the contrasting extremes are bridged by a series of similar or harmonious steps. Gradation therefore, is a particular combination of contrast and harmony. Gradation is clearly illustrated by the value scale; in which black and white, the contrasting extremes, are connected by a continuous sequence in which the adjoining grays are similar or harmonious. The word 'scale' derives from the Latin word 'Scala' which means steps, stairs or a ladder. Gradation of hue, value and chroma that progresses from the pale, warm-green horizon haze to the dark, cold blue.

6.6.4 Emphasis

The dictionary meaning of the word "Emphasis" is to stress, to give importance or significance. Emphasis is the art principle by which the eye is carried first to the most important thing in any arrangement and from that point to every other detail in order of its importance. While doing emphasis in a dress one should understand the following aspects.

- What to emphasize?
- How to emphasize?
- How much to emphasize?
- Where to place emphasize?

6.6.4a What to emphasize?

We need to be aware of the many possibilities of what to emphasize. Backgrounds should be less conspicuous than the objects to be seen against them.

6.6.4b How to emphasize?

On deciding what to emphasize the next step is how to give emphasis to that particular portion in a garment. How it should be done? How to place an emphasis? There are several ways by which one may create emphasis by grouping or placing of objects, using contrast colour, using decoration, having sufficient plain background space around objects and by using unusual lines, shapes or sizes.

- **Grouping or placing of objects**

Grouping or placing of objects can be achieved by grouping objects which are similar in usage, materials, idea, size, etc. while arranging a particular area. In a garment, grouping may be done for decoration at one particular area. For example in a single piece garment, a bow and decoration using beads may be done.

- **Emphasis through contrast of colour**

An eye is quickly attracted by strong contrasts of light and dark or by contrasting colour. A striking contrast of light and dark are to be used in any decorative scheme of a considerable size. This application on garment emphasizes and makes the garment more attractive.

- **Emphasis through the use of decoration**

Structural as well as decorative design should be so beautiful that it will enhance the beauty. A surface pattern that is good for a background has two main characteristics, first the design covers the surface rather closely, and second there is very little contrast between the lights and the dark. The

garment may be decorated with embroidery, sequins, beads or lace.

- **By unusual lines, shapes or sizes**

Emphasis can be gained by means of contrasts or unusual lines and colours. In garment designing and decoration, while making use of different lines like straight or curve, unusual lines are used to create emphasis. This is brought through princess lines, yoke designs etc.

6.6.4c How much to Emphasize?

Emphasis may be regarded as a graded scale, and the greatest amount of force that can be used with good taste for each of these types will come at a different point on these imaginary scales. Levels of emphasis may be Emphatic, Dominance, Sub dominance and Subordinate The emphasis on garment should be made in such a way that it doesn't dominate too much. It should emphasize the whole garment but should not spoil the effects through its domination. (Figure 6.33).

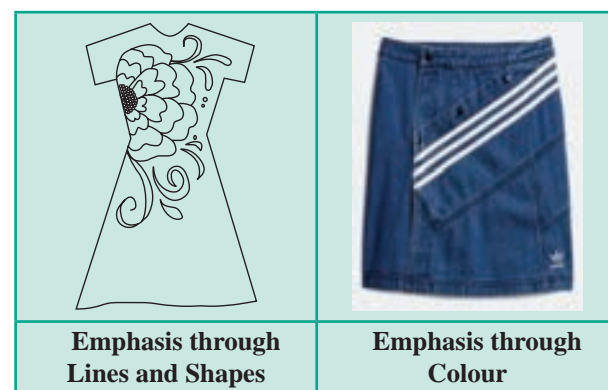

Figure 6.33 Emphasis

6.6.4d Where to emphasis?

Emphasis should be done at the required points in the garment. Example: Waist line, sleeve edge etc.

6.6.4e Emphasis in Colour

It can be achieved by contrast of hue, light and dark and brightness, the effect of every other colour used. In the arrangement, the emphasizing colour should be subordinated to the main colour to prevent confusion.

6.6.5 Balance

Balance in design is so natural that one is not even aware of it when it is present, but when it is violated there is a sense of discomfort or annoyance. (Figure 6.34).

6.6.5a Formal balance

If objects are alike or are equally forceful in appearance they will attract the same amount of attention, therefore should be equidistant from the centre.

6.6.5b Informal balance

If, however, objects do not attract the same amount of attention, they must be placed at different distances from the centre. This second type of balance is called informal, or occult, or asymmetric balance. Informal balance is more subtle than formal balance and affords greater opportunity for variety in arrangements. Its success depends upon training the eye to recognize a restful composition.

Whether one uses formal or informal balance depends largely upon the following conditions.

1. The spirit of the age in which one lives
2. The use to which the garment is to be put
3. The type of people for whom the dress is planned
4. One's own personality

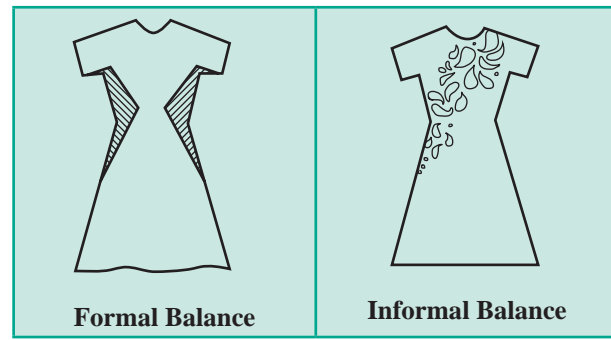

Figure 6.34 Balance

Balance in Colour

Balance or the feeling of rest underlines the well known “Law of Areas”. The law of areas is also known as “The law of backgrounds”. This law states large areas of colour should be quite in effect, while small amounts may show strong contrast; the larger the areas quieter the colour and smaller the area the more striking the contrasts may become. This contrast may be done due to a decided difference in hue, in value or in intensity.

A small quantity of light value will balance a large amount of a dark value or small amounts of dark can balance large areas of light.

The hues which are directly opposite to each other in the chart form a natural balance because they complement each other in the eye. Balance of colours can also be achieved by selecting the varied amounts of bright and dull colours and by arrangement of these colours. By repeating some of the colours, colours or values can be balanced, in various parts of an arrangement this is also called a ‘crossing’ which has tendency to give a feeling of rest.

6.7 Summary

These elements of design are arranged as per the principles of design to obtain a perfect

and pleasing design output in garments. This not only applies for garments but also for home interior decorations and so on. Understanding these basic aspects help a designer or decorator to beautify the garment or furnishing items. The psychology and optical illusions may also be brought well for the wearer. Colours are beautiful for the purpose for which

they have been chosen. Colours are so combined as to enhance one another's beauty. Colour is beautiful if it is used in the right place and in right amount. It may be a floor covering upholstery material, wall painting or any decorative art piece. By understanding the concepts of elements and principles of design the best clothing design may be done.

POINTS TO REMEMBER

- Design is the arrangement of elements such as line, shape, colour and texture according to the principles of design namely harmony, rhythm, emphasis, balance and proportion.
- Value gives the lightness or darkness of a colour.
- Intensity is the brightness or dullness of a colour which denotes the strength and weakness of a colour.
- Harmony means unity.
- Monochromatic means 'of one colour' and it is the simplest of all other schemes to use, because it is based on only one hue.
- Balance or the feeling of rest underlines the well known Law of Areas.

ACTIVITIES FOR TEACHER

- Can show the fashion pictures depicting the elements and principles of designs.
- Can show the pictures and inspirations taken up by various Indian Designers.
- Can orient the students about the scope of designing in Fashion world.

ACTIVITIES FOR STUDENTS

- Can read and collect some data about successful designers and prepare an assignment.
- Can collect the pictures pertinent to various elements and principles of designs
- Can sketch the designs as per the principles of design.



INTERNET RESOURCES

https://www.youtube.com/watch?v=QLva6QMb_3o	Introduction to Fashion and Textile Design - Oxford Royale Academy
https://www.youtube.com/watch?v=FPc4Xr93z5o	How to design your own fabric. Step-by-step fabric design tutorial with final fabric example.

A-Z
GLOSSARY

Naturalistic Design	When objects from nature are used as such, it is known as naturalistic design. The designs can be selected and reproduced exactly with photographic correction
Abstract Design	Motif which does not have the nature as the source but the combination of lines producing irregular
Geometric Design	It is not derived from nature. It is derived from circles, rectangle, triangle, parallel lines and so on.
Zigzag lines	A zigzag is an angular shape characterized by sharp turns in alternating directions.
Jagged	Jagged lines are not in order and these give a feeling of anger and disorder
Tapering	This type of line taper towards the end. The initial portion is broader and it narrows towards the end.
Hue	It is the name of a colour. A degree of lightness/darkness, strength etc.
Primary colours	These are the fundamental colours

QUESTIONS AND ANSWERS

PART – I

Objective Questions

- The design feature that is used more than once is
 - Rhythm
 - Repetition
 - Design
 - Harmony
- Pink is a tint of
 - Blue
 - Green
 - Red
 - Yellow
- Feeling of continuity
 - Rhythm
 - Harmony
 - Emphasis
 - Balance
- A darkened colour made by adding black
 - Warm
 - Cool
 - Shade
 - Tint



- Split complementary colour scheme uses
 - 3 colour
 - 4 colour
 - 2 colour
 - 1 colour

PART – II

Answer in Three (Or) Four Points

- Define Design.
- Differentiate structural design and decorative design.
- What is a harmony?
- Describe emphasis
- What is Colour harmony?
- Give the types of balance.
- What are primary colours?
- List the types of lines

PART – III**Answer in a Paragraph**

1. What are the types of design? Explain.
2. Give the types of lines and their characteristics.
3. Write a detail note on shape and form on garments.
4. Give an account on rhythm on apparels.
5. Enumerate on the application of principles of design on texture.
6. Write a note on classification of lines based on measures and characters.

PART – IV**Answer in One Page**

1. List and explain various elements of design.
2. Elaborate on related colour harmony.
3. Give a detail note on emphasis with suitable diagrams.
4. Give an account on contrasting colour harmony.

Answers for Objective Questions

1. (b) 2. (c) 3. (a) 4. (c) 5. (a)

CHAPTER

7

Identification of Fabrics and Preliminary Stitches in Garment Construction

LEARNING OBJECTIVES

- To learn about fabric grain and its types
- To understand the different types of stitches



7.1 Introduction

Textile material has various end uses. When one has to select a material he/she touches it and observes the look and feel of it, based on which the decision of selecting the material for a specific end use is determined. The knowledge among various forms of fibre, yarn and fabric will enable in understanding the fabric qualities. In order to know the kind of fibre present in the textile material burning test, chemical test and physical tests are performed, but to understand the suitability of the fabric for garment look and feel is examined based on which decision will be taken. The most common materials include cotton, wool, silk, linen, rayon, nylon, polyester, satin, sateen, velvet, brocade, worsted, chiffon, georgette, crepe, dimity, netted, lace and crochet. Different types of materials are available in the market for a designer to choose and design a garment.

7.2 Identification of Fabric by Feel

Fabrics can be identified based on the texture, which means the surface feel of a fabric. Example – the feel of gauze bandage, cotton sari and a denim pant material. All these have different feel when touched. Thus, the texture is observed and based on that the fabrics can be identified for its suitability to a chosen end application area, like whether the fabric can be used for pant, shirt or frock.

Table 7.1 Different types of Fabrics and their Surface

Name of the Fabric	Feel
Synthetic sari (chiffon)	Soft
Georgette sari	Silky
Denim jeans	Rough
Felt (Bindi)	Hairy
Leather	Rough and grainy
Gauze cotton bandage	Light and netted
Knitted underwear	Extremely soft
Sweater and knitted jerkin	Flexible and cozy
Door mat	Prickly
Terry Towel (Pile)	Bumpy
Silk (sari)	Soft and Smooth

7.3 Identification of Fabric by Look

Fabrics can be assessed by the appearance. This is generally based on how it takes up light and reflects or absorbs it. There are different types of fabric dull, bright, shiny, glossy, transparent, embellished, thick, heavy, light, fine, semi-transparent, embroidery, lace, knotted to mention a few.

Table 7.2 Different types of Fabrics and their Look

Name of the Fabric	Look
Denim	Dull
Silk	Shiny
Cotton	Transparent and Light weight
Wool	Hairy
Satin fabric	Shiny
Embroidered fabric	Rough
Linen	Coarse
Glitter print	Glossy
Velvet	Very smooth
Polyester (sari)	Bright
Woollen (Jerkin)	Soft
Pile fabric	Fibrous
Transparent fabric	Flimy
Carpet	Fleecy
Lace	Lacy
Bed	Quilted
Sweater	Ribbed
Denim (pant)	Stonewashed
Shiny legging	Stretchable



Figure 7.1 Different Types of Textile Materials

7.4 Grain

This is the term that explains the direction in which the fabric is woven. It determines greatly by the way the fabric falls on the object



or the wearer. Understanding the grain helps in minimising the wastage and to create interesting fullness effects on the garment. Grain refers to the alignment of warp and weft yarns inside a fabric. When the fabric is selected for construction the grain line is analysed. When grain is not in the proper angle steps are taken to make it right. Also, diagonal grain is chosen when the design requires more flexibility for good fit or fullness for decoration. The common type of grain seen in garments is the straight grain. The main reason for this is, to get full strength for the garment which can be obtained when the garment is cut in the same direction as it was constructed. Apart from this, the perfectly twisted warp yarns that work like a skeleton on the fabric is very strong. The combination of that warp along with the weft will enable good compaction and better properties when cutting a garment pattern. In order to check if the fabric is on proper grain, one thread can be ravelled from selvedge to selvedge and then the fabric is folded on half. If this can create neat edge in the bottom, it is said that the material has been laid on proper grain. There are different types of grain which are explained below:

7.4.1 On Grain

Lengthwise grain means the yarn in the fabric runs in the length of the fabric and is parallel to the selvage. Crosswise grain

has threads that are perpendicular to the selvage of the fabric. The term on grain refers to the length and crosswise thread being right angle to each other. This is very basic in woven fabric as they are made by warp and weft interlaced at right angle to each other.

7.4.2 Off Grain

When the warp and weft threads are not exactly at the right-angled ways, they are termed to be in off grain. This is usually a defect and methods are available to set the grain to the on-grain line.

7.4.3 Bias Grain

When the garment pattern is cut at 45 degrees it is called bias grain. This has a good drape as it is taken in the diagonal way. Further extending of the pattern tends to increase the fall of the fabric and gives beautiful wavy effect.

7.4.4 On Grain Print

This is when the print is neatly lined up with the warp yarns and is parallel to the selvage. It is on grain print and results in a neat look of the design on a fabric.

7.4.5 Off Grain Print

In contrast to the above on grain print, off grain is the printed set of design which is not parallel to the selvage. This can be considered as a defect in printing as it directly implies poor quality in printing.

It is also important to remember that when the textile material is made in a weaving loom or a knitting machine it will be in the perfect grain only. During the various textile processes like washing, calendaring, scouring, mercerisation the selvage are held tight resulting change in the grain lines. When the grain line is not maintained in the way it should be done, there are chances for the fabric to lose shape, sag and even be uncomfortable to wear.

DO YOU KNOW? At which angle does bias grain run in a fabric?

The bias grain runs at 45° angle, to the selvages on any fabric.

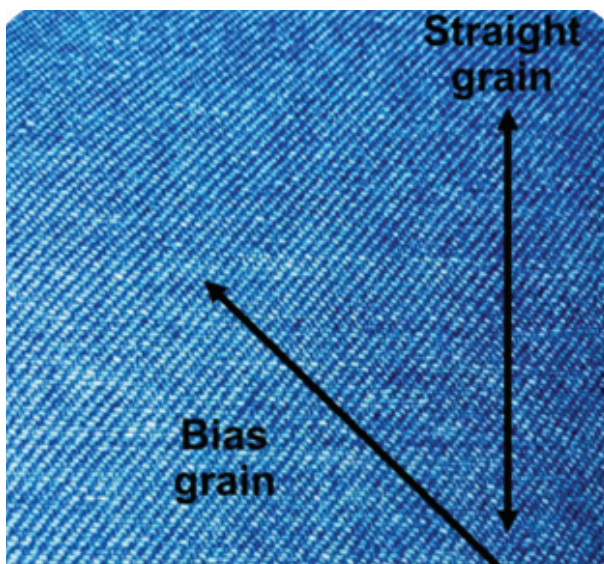



Figure 7.2 Types of Grain

7.5 Identification of Right and Wrong Side

7.5.1 Woven Fabric

Weaving is the art of interlacing warp and weft at right angle direction. This compact construction creates a strong fabric. In order to identify the right side of the fabric, the design on the woven fabric should be observed. When the floats of a design are less and the motif is clear it is the front side of the woven fabric. Contrastingly, when the motif is of dull shade or more



floats (loose unwoven threads) are seen on the surface that is the back side of the fabric. This is a very typical case of a jacquard fabric.

7.5.2 Knitted Fabric

When the fabric has loopy structure, and is extremely stretchy they are made by means of knitting. The looped structure of the knitting creates a very good drape like that of socks and warm feeling like the innerwear and sweater. The sample can be termed as knitted, when the closer view of the material reveals loop like structures. Examples are baniyan, panty, slip, sweater and jerkin.

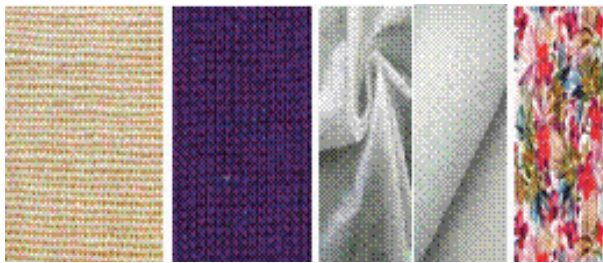

Figure 7.3 Woven, Knitted, Non-Woven and Printed Fabric

7.6 Non-Woven Fabric

A non-woven fabric is made by using heat and resin on short fibres, thereby creating a structure for the short fibres. They are materials that do not have a fibre network by randomly laid technique. One cannot see the warp and weft threads laced or looped like a weaving or knitting.

In order to check if the sample is a non-woven material, the sample can be given pressure and it can be observed that it can tear like a paper. For example, we can think of the tissue paper given in hotel or the sanitary napkins centre part. On scratching the surface of the fabric, the short fibres, will tend to come away with the fingers. This behavior can be observed

on a felted craft paper and bindi that is kept by women. By conducting such small tests, we can identify the non-woven fabric.

7.7 Printed Fabric

Printing is defined as localised dyeing. The identification of right and wrong side of the printed fabric is very essential in order to get the material made into a garment. During construction, the alignment of the print to seam or the pocket area is seen as prime importance. When the prints are not matched in the front panel, the pocket, seams it will give a bad outlook on the wearer. Care should be taken to inverse the fabric and to match the exact print.

7.8 Introduction of Preliminary Stitches

Stitches are row sewing that enable in building the strength of two pieces of fabric the basic stitches and their method of construction is discussed below.

7.8.1 Stay Stitch

This involves giving one row of stitch on a single layer of a fabric that it intended to prevent the fabric from distortion or excessive stretching. It is commonly used on a bias strip where the stitching is done on the extreme end of the strip taken.

DO YOU KNOW? Why is Stay Stitching needed?

Stay Stitching is the best way to offer stabilisation and protect your fabric against raveling.



7.8.2 Basting and Pin Basting

This is a long running stitch that is done on a fabric to hold two pieces of fabric temporarily until the final machine stitch is given. Pin basting is when this process is accompanied with the pins to give a neat finish on the sample and to hold heavy fabric easily using pins. In either case, it is a rule to remove this temporary stitch after the final sewing is done using machine.

7.8.2.1 Machine Basting

When the tailors are making an alteration, they give a row of machine stitches that are long and can be easily removed by using a seam ripper. Before making a permanent alteration, the temporary long stitch given using a machine is called machine basting.

7.8.2.2 Slip Basting

This type of stitch is used when a piece is temporarily attached to a sample and to

ensure if it matches well. In particular it is used at the hems, facings, folding, where invisibility is important.

7.9 Summary

Designers and merchandisers should have a basic idea of fabric. Methods to identify them are by visual look and the feel. Grain is an important factor that directly determines the ease in construction and final look of a garment. It is important to know the different styles that can be achieved by understanding grain. Understanding the right and wrong side of woven and pints helps in obtaining the required outlook of a garment. The preliminary stitches are explained in this unit that are very helpful in holding a fabric in temporary and permanent way.

POINTS TO REMEMBER

- There are different types of fabric dull, bright, shiny, glossy, transparent, embellished, thick, heavy, light, fine, semi-transparent, embroidery, lace, knotted to mention a few
- On grain, off grain and bias grain are the three basic grain lines
- Bias at 45 degree is true bias
- On grain and off grain print determine the quality of printed fabric
- There are different kinds of textiles namely woven, knits, non-wovens and prints.
- Printed fabric does not have design on the wrong side
- Preliminary stitches like basting – machine, slip pin used to hold the fabric in place before it can be made into a final garment.

ACTIVITIES FOR TEACHER

- The teacher can work and show a sample of stitches.
- Can show the album with different types of fabric

ACTIVITIES FOR STUDENTS

- Prepare an assignment showing the right and wrong side of the fabric (minimum of five samples)
- It can be planned to make students to wear different dresses on a particular and let the students observe the different look and feel of fabric.



INTERNET RESOURCES

https://www.youtube.com/watch?v=KF60qVY83j4	How to straighten a fabric
https://www.youtube.com/watch?v=C0wJub8KM5A	How to match printed fabric
https://www.youtube.com/watch?v=41pTuij_GTg	How to pattern match fabric seams

A-Z GLOSSARY

Fabric	Made using thread into a sheet of textile
Selvedge	The edge of a fabric, thick in nature
Stitch	Row of sewing
Grain	Direction of warp and weft thread
Print	Design on the surface of the fabric
On grain	Strip correctly matched with warp and weft direction
Off grain	Incorrect with the angle to the warp and weft

QUESTIONS AND ANSWERS

PART – I

Objective Questions

- Fabric that has bumpy texture.
 - Pile
 - Cotton
 - Wool
 - Synthetic
- In order to make a permanent change in the garment, the tailors use this temporary stitch to check fit before final machining.
 - Slip stitch
 - Running stitch
 - Machine basting
 - Hemming
- Texture of this material resembles human skin.
 - Cotton
 - Silk
 - Wool
 - Leather
- fabric is made by using heat and resin on short fibres.
 - Non-woven
 - Woven
 - Leather
 - Knitted



5. When the garment pattern is cut at 45 degrees it is called -----
- Bias grain
 - Off grain print
 - On grain print
 - On grain

PART – II

Answer in Three (Or) Four Points

- Give the different types of fabric and their look and feel properties
- Explain the method to identify by feel
- List on the different types of grain.

PART – III

Answer in a Paragraph

- Write the methods to find the woven and printed fabric
- Why is grain important in designing?

PART – IV

Answer in One Page

- What is grain? Explain its types.
- Give the list of preliminary stitches and methods to construct them.

Answer for Objective Questions

1. (a) 2. (c) 3. (d) 4. (d) 5. (a)

Laying the Pattern, Marking and Cutting

CHAPTER

8



LEARNING OBJECTIVES

- To learn about the pattern laying methods
- To understand the pattern marking and cutting techniques

8.1 Introduction

Dress designing is an art which includes aspects like preparation of fabric dress patterning, marking, cutting and sewing. Each of these aspects need to be done with great care. In garment making, a pattern is the outline of a garment which is traced onto fabric before cutting the fabric. Patterns are usually made of paper, and are sometimes made of sturdier materials. Pattern made of cardboards can withstand repeated use. Laying the pattern, marking and cutting are three important aspects in dress designing and construction. Pattern laying refers to the placement of pattern on fabric. The process of marking or cutting patterns is sometimes referred to as Patternmaking.

A sloper pattern (home sewing) or block pattern (industrial production) is a

custom-fitted, basic pattern from which patterns for many different styles can be developed. The process of changing the size of bigger or smaller a finished pattern to either is called grading. Marking includes aspects like transferring the pattern lines on the fabric and cutting explains the method of piecing the fabric into patterns similar to that of paper pattern. It can be rightly called the life line of apparel design and construction.

8.2 Brief on Basic Pattern

Drafting and pattern making are the basic necessities for making fashion garment. Human form is a compound of complex geometrical shapes and presents a problem in pattern construction. The accuracy of any pattern making method depends largely on relevant and correct measurements. Pattern making can be further divided into two sub-headings namely measuring the body or dress form accurately and knowledge of making a good pattern. Pattern making systems are largely dependent. This is influenced by the accepted style of that particular period. Seam placement is suppression

are an integral part of drafting. Fashion designing has come a long way in style, pattern making techniques and manufacture of garments. The most common method of pattern making is described below. It is also known as tailor's pattern making technique. The measurement mentioned in the pattern is suitable for normal adult (20-21 years). The measurements for marking points at shoulder or armhole can be reduced or increased depending upon age or type of figure of the individual.

The most common method Back Bodice Pattern of pattern making is described below. It is also known as tailors pattern making techniques. (The measurement mention in the pattern is suitable for a normal adult (20-21 years). The measurement for marking points at shoulder as armhole can be reduced or increased depending upon age or type of the figure of the individual.

8.3 Back Bodice Pattern

- Draw a rectangle using the following measurements. Be sure to leave at least three centimetre margin around the rectangle. Point A-B = $\frac{1}{4}$ bust circumference - 1 cm + 0.5 cm (for ease). Points A-C = back length. Now close of the rectangle making sure it is perfectly squared (each corner should be 90° angle)
- From points C-E and D-F mark the side length measurement connect points E and F with the straight line.
- From points A-H and E-G mark half the back width connect points H and G with the straight line.

- From point A-I mark down about 1.5 – 2 cms. From point A-J mark one tenth the waist measurements. Connect point I-J with a slight curve. This is the neck hole of the bodice.
- From point H down to K mark 4.5 cm. Draw a straight line from point J-K over marking K by 0.5 cm that slightly over so that it will be pointed at L.
- Mark a 3 cm from point G-M. Now connect points F, M and L with a curve. This is the armhole for your bodice.

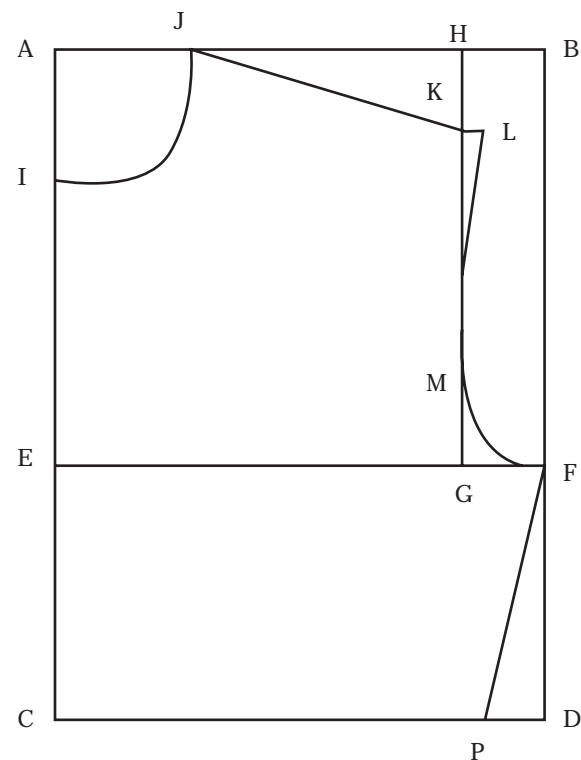

Figure 8.1 Back Bodice Pattern

- From point C-N mark 9.5 cm
- From point N-O mark a perpendicular line 15 cms long. Mark 1.5 cm to either side of point N and connect both these points to point O with a straight line. This will be the back dart
- From point C-P mark $\frac{1}{4}$ th of waist measurements - 1 cm + 3 cm - 0.5 cm. Connect points F-P with a straight line.

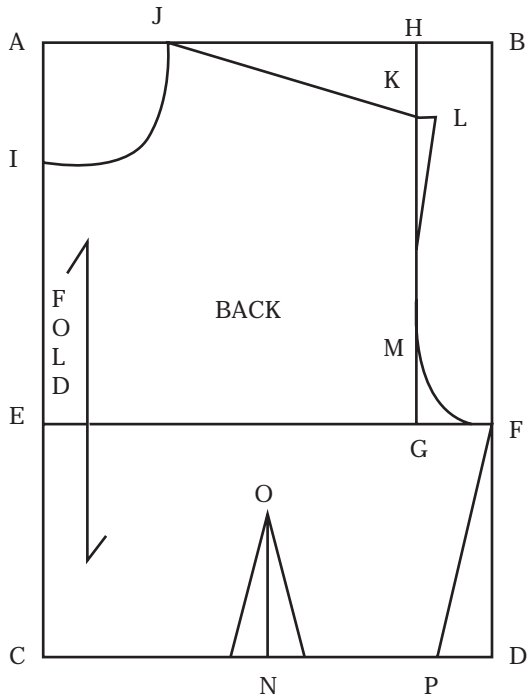

Figure 8.2 Back Bodice Final Pattern

8.4 Front Bodice Pattern

- Draw a rectangle using following measurements. Point A - B = 1/4 bust measurement + 1 cm + 0.5 cm (for ease). Point A - C = front waist length. Now close of the rectangle making sure it is perfectly squared.
- From point C - E and D - F mark the side length. Connect points E and F with a straight line.
- From point B - H and F - G mark in 5 cms. Connect points G - H with a straight line.
- From point G - I mark a 6 c
- From point A-J apply one tenth the waist measurement + 1 cm. From point A-K apply one tenth the waist measurement, Connect J-K.
- From point B-L mark down 9 cms. Connect points K-L.
- From point E-M mark 1\2 the bust separation.

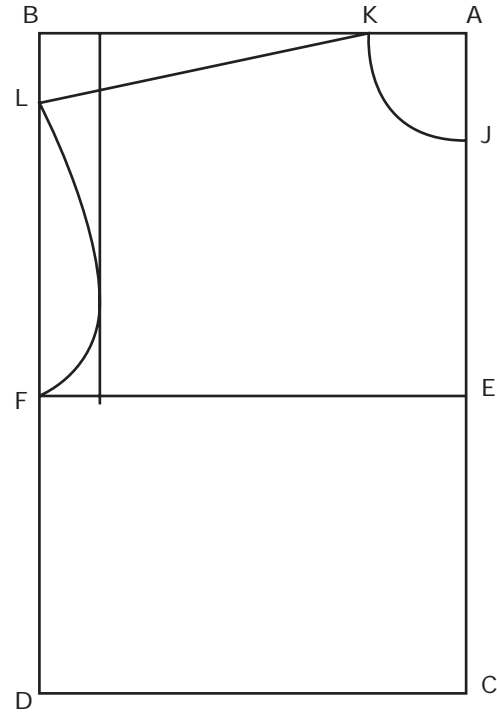

Figure 8.3 Front Bodice Pattern

- From point A-N mark down 5 cms. Then from N mark down another 6 cms and mark that O. Connect both points N and O to M using straight line.
- From point C-P mark into the same measurement as E-M. Draw a vertical line point F-Q. This line should be 15 cms long.

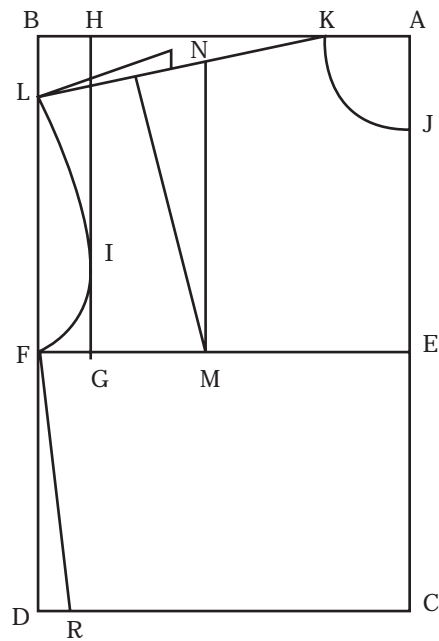

Figure 8.4 Front Bodice Final Pattern

- Mark 1.5 cms to either side of points O and connect both these points to point Q (waist dart).
- From point C-R apply $\frac{1}{4}$ th waist + 1 cm + 3 cms + 0.5 cm. Connect R-F with a straight line.
- Connect L, I and F with a curve (armhole).
- Cut out the pattern except leave the 3cm margin at the top shoulder. Close the shoulder dart following the flap in the back towards the armhole. Tape it shut, then redraw the shoulder line. Cut straight across the new shoulder line.

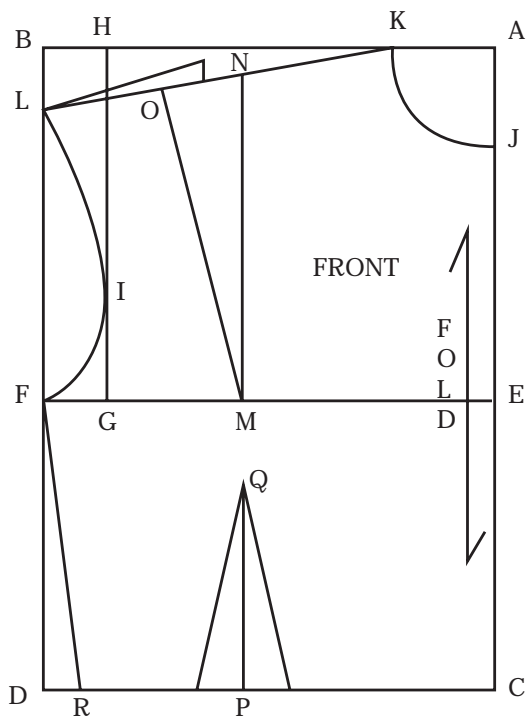

Figure 8.5 Front Bodice Pattern Working

Sleeve

- A-B sleeve = sleeve length $7 \frac{1}{2}$ inches (19 cms) to $7 \frac{3}{4}$ th inches (20 cms).
- A-C = $4 \frac{1}{2}$ inches (12 cms).
- Square points C and B to the right.
- A-D = $\frac{3}{8}$ inch (1 cm).
- D-E = $\frac{1}{2}$ armhole measurement.

- B-F = $\frac{1}{2}$ lower arm girth + $\frac{3}{8}$ inch (1 cm).
- Connect E-F and D-E.
- Divide line D-E into 4 equal parts and mark G, H, I.
- G-J raise $\frac{5}{8}$ inch (1.5 cm).
- I-K lower $\frac{5}{8}$ inch (1.5 cm). Connect D, J, H with a French curve.
- Connect E, L, H with a French curve (for front sleeve cap). H-L $\frac{1}{4}$ inch = 10.5 cm.

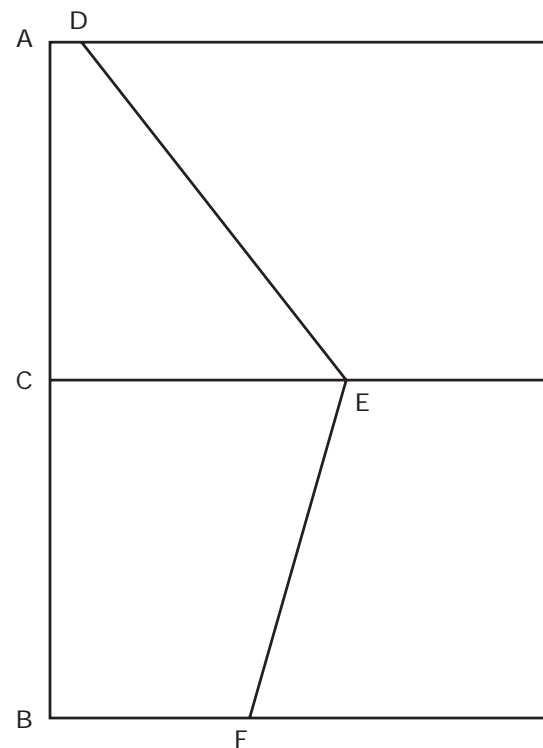

Figure 8.6 Working Sleeve Pattern

- M centre of K and I. Connect J, L, M and E for back sleeve cap line with a dotted line.
- Cut off L-E and F-E. Open the sleeve and cut E, K, H to J for front sleeve pattern.
- After drafting the basic pattern check it correctly and accurately, especially the measurements and the parts of pattern pieces and then cut the basic pattern the following cutting line smoothly.

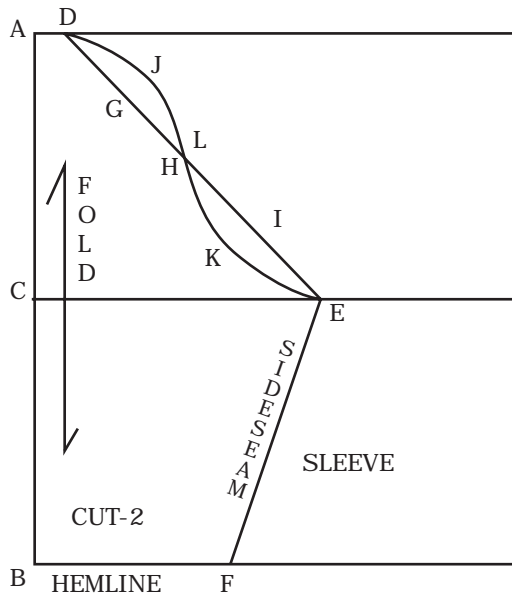

Figure 8.7 Final Sleeve Pattern

Garment Construction

- Join front and back bodice by the shoulder.
- Attach the sleeve at both left and right side.
- Before attaching sleeve, the hem of the sleeve should be fold stitched not showing the raw edges.
- The neck line should need to be fold stitched at both front and back side.
- At last the front and back hem should be fold stitched not showing the raw edges.
- The thread colour should match the fabric that used.

8.5 Types of Layout

Laying out the pattern on the fabric to prepare for cutting is an important step, that must be done carefully and accurately for great looking results.

A well sewn garment starts at the cutting table. Laying out your pattern on the fabric



to prepare for cutting is an important step that must be done. Layout has to follow a specific pattern which mainly depends upon the type of the garment, the pattern pieces and the width of the fabric. The types of layout are lengthwise centre fold, off centre lengthwise fold, cross wise centre fold, off centre cross wise fold, combination fold and open layout.

Principles of Pattern Laying

Some of the principles to be followed while laying patterns:

1. Press the fabric as well as the pattern pieces flat before laying the pattern on the fabric.
2. Use a large table or any hard flat surface for accommodating the work.
3. If an open layout is used, place the fabric right side up on the table. For all other layouts fold the fabric right sides facing and wrong sides out.
4. Decide on the best way to fold your cloth this will depend on the width of the cloth, width of your pattern pieces, the type of cloth and design of the garment (whether left and right halves are identical. Whether many pieces have to be cut on fold the garment (whether left and right halves are identical, whether many pieces have to be cut on fold)

8.6 Preparation of Fabric for Sewing

Preparation of fabric for cutting and sewing involve the following steps :

- Straightening
- Shrinking
- Pressing

Straighten the Grain of the Fabric

The grain of the fabric should be checked thoroughly. The cross wise grain is composed of fabric threads that run parallel to the cut edges of the fabric. While the length wise grain, on the other hand, is composed of fabric threads that run parallel to the selvedge edge, the self-finished edge of the fabric.

Knit Fabrics

In knit fabric, cannot be straightened by pulling a thread. To find a straight line, in knit fabric, contrasting-colour thread is used to hand-baste across a crosswise loop. Then fabric is cut along the basted line. This gives a straight edge for folding the fabric and laying out the pattern.

Serge the Cut Edges of the Fabric

An over lock is a kind of stitch that sews over the edge of one or two pieces of cloth for edging, hemming, or seaming. Usually an over lock sewing machine (sergers) will cut the edges of the cloth as they are fed through the machines. Serging is done to prevent unravelling of fabric

Prewash the Fabric

- Most fabric need to be pre washed because many of them including cotton, flannel and knitted fabrics can shrink significantly when washed.
- It is important to wash such fabrics before use.

Iron Out the Fabric

- Iron out the fabric after prewashing of fabric.
- Appropriate amount of heat should be used on the fabric to remove creases and wrinkles

8.7 Designing

Textile design is essentially the process of creating design for woven, knitted or printed fabric or surface ornamented fabrics. Textile designers are involved with the production of this design in clothing. The field encompasses the actual pattern making while supervising the production process. Textile design fulfils a variety of purpose in our life. For example: clothing, carpets, drapes, towels and rugs are all a result of textile designs.

8.8 Pressing

Never cut wrinkled fabric because it will result in no longer or smaller fabric pieces. Pressing the fabric before sewing is very important. The fabric needs to be as flat and as smooth as possible while sewing. Sewing a wrinkled or creased fabric will lead to a continually wrinkled or creased project. Sewing these flaws into the project and crease in particular can be very hard to remove from a project, especially if the crease is stitched into the final product. Pressing fabric before sewing ensures that these issues do not arise.

8.9 Preparation of Special Fabrics for Sewing

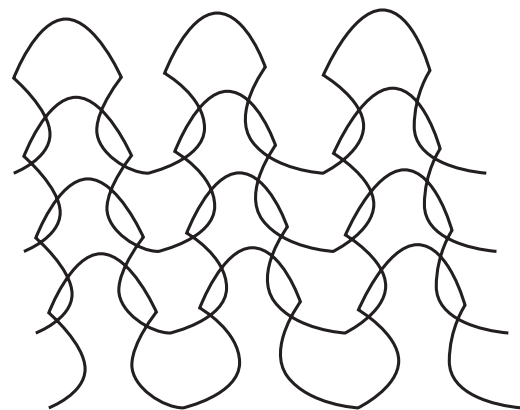

Figure 8.8 Knit Structure

a. Knits

Knits are an important part of every wardrobe because they are comfortable to wear and easy to care. Because of their elasticity, knit garments do not require a lot of fitting and they shed wrinkles well. Most knits do not ravel, making them quick and easy to sew. Knits are versatile and can be seen in everything from the most casual wear to the formal clothing attire. They come in a variety of fabrics that vary in textures, elasticity, fibre content, weight and design.

Points to be considered before preparing knitted fabric :

- Washable knits tend to shrink more often and to a greater degree than woven fabric.
- Always purchase extra yardage to allow for shrinkage. For best results wash and dry the fabric before cutting.
- Washing also helps to relax the fabric and remove the fabric sizing.
- Excess sizing can cause skipped machine stitches, pre shrink firm, interfacing, lining and garment.
- Generally, rib knit net should not be prewashed. Washing softens it and makes it difficult to cut accurately.

b. Silk Fabrics

Silk is a luxurious and sensuous fabric that has been coveted for centuries. Silk, which originates from the cocoons of silkworms, is also the strongest natural fibre. The slippery and smooth texture of this fabric poses some difficulties that require special care when sewing. There are simple techniques to make silk easier to handle and sew for every stage of a handmade sewing project.

Washing

Wash your silk in warm (hot) water using a special washing detergent for delicates.

Hand Washing

Hand washing is preferred but machine washing on delicate cycle is also acceptable. Many silk pursuits claim that the best thing to wash silk is shampoo. While washing silk, rub, twist bringing or scrunching. Rinse should be done fabric several times in cold water. If silk is rinsed in vinegar solution the colours will look brighter and the surface will look brighter and shine.

Drying

Silk fabric should be dried away from direct sun or heaters. Silk fabric should not be over dried or pressed. Wrap the silk in a damp cloth and put it in a plastic bag for a couple of hours. This should evenly “moisturize” fabric and then press it. Silk, must be pressed with dry iron, because steam might cause it to wrinkle.

Pressing and Inspecting

The ironing should not be too hot or it should not have snag on the sole of it. Use a sheet of baking paper to protect the fabric. If the silk has some stretch, it is best to press it through another layer of fabric such as cotton and silk.

Rayon has been around for many years and the processes used to create it were pioneering in the early manufacture of materials. It is an integral part of the fabrics for nowadays, Rayon is a fibre and not a completely natural product because it undergoes several chemical processes. However, it is extracted from the cellulose



in wood pulp and it is not entirely artificially fibre

- Wash fabric: Rayon shrinks easily. It needs to be pre washed, dried, thinned and iron it before sewing.
- Laying fabric: Lay an old, clean sheet or some cotton fabric on the table. Then lay fabric to be cut.

c. Lace

Lace can be a difficult fabric to sew. It can be used along with the right complementary materials.

● Pre Wash

Lace can be stiff and difficult to work with before it has been washed. To make it easier to sew lace fabric, wash gently by hand and then lay the fabric flat to dry. Use a gentle fabric detergent and lukewarm water to wash lace by hand in a clean sink or bucket. Avoid wringing out the lace, squeeze it gently to get the excess water out.

● Ironing

The lace fabric need not to be ironed. However if there are wrinkles put iron on the lowest setting and iron the fabric in sections until all the wrinkles are removed. Lace fabric placed over a towel or cloth to protect it while ironing.

d. Velvet

- It is a soft pile fabric and it is woven in two layers. The top is made of layers using different fibres like rayon, silk and polyester. It has a plain under side and a very distinct pile on right side. Velvet drapes well. It suits simple semi fitting styles.

- Flat seams should be used. Velvet is not very forgiving of holes made by incorrect stitching. Velvet has a very distinctive nap or pile and it is very important to make sure to have the nap going the same way.
- The most common choice of nap is one which goes down the garment. When seen at the right side it looks soft and has a shimmer.

e. Satin

Wash the fabric before sewing. It is also a good idea to run a over lock along raw edges before washing, as these types of fabric are really prone to fraying. Press on a low heat setting, and with a clean iron. Press from the backside or put a pressing cloth especially for the delicate fabric satin.

8.10 Spreading of Fabric

Fabric spreading is a method where piles of fabric are spread a specific length and width wise according to the garment marker measurement. A proper fabric spreading process may have an effect on productivity, quality and cost of the production. Fabric spreading is an important task to maintain proper shape of fabric before cutting of garments. There are two methods applied in garment industry for fabric spreading process. They are manual method and mechanical method. The manual method is totally hand spreading method, therefore this process is quite slow on the other hand. Mechanical method is two types, they are semi-automatic and full automatic.



8.10.1 Types of Fabric Spreading

The spreads can be of two basic types :

- **Flat Spreads**

All piles are of the same length.

- **Stepped Spreads**

As the name suggests, the spread is built up in steps, with all the plies in one step having the same length. A stepped spread is generally used when the quantities to be cut is more. According to the order plan details the cut number, colour and ply length is done for stepped spread method.

8.10.2 Requirement of Spreading Process

- Alignment of plies in both length and width direction.
- Elimination of fabric defects/flaws.
- Correct ply direction (especially for asymmetrical printed fabric) all face up, all face down, face to face etc.
- Correct ply tension- ply tension must be uniform and as much as possible.
- Avoidance of distortion in the spread during cutting.
- Fabric must be flat and free from any wrinkle and crease.
- Checks and stripes should be matched.

8.11 Laying The Patterns

A fabric has to be prepared well it should be pre-shrunk and ironed before the patterns are placed on it. The fabric has to be spread neatly on a clean large table. One can even use a clean floor. Remember to use a surface bigger than fabric, so that overlapping of the fabric or mismarking can be avoided.

Different Types of Layout

Layout has to follow a specific pattern, which mainly depends upon the type of

the garment, the pattern pieces and the width of the fabric. The different types of fabric layout namely lengthwise centre fold, off centre lengthwise fold, cross wise centre fold, off centre cross wise fold, combination fold and open layout.

8.11.1 Pattern Laying of Special Fabric

Pattern laying need extra care when the fabric vary like knits or silk.

8.11.1.1 Knits

The inter looping of a single yarn is known as knitted fabric. There are various varieties of knitted fabrics like single and double jersey, tricot and rib. Jersey fabrics are mostly used for garment construction.

- Pulling or tearing should be avoided to straighten the fabric.
- Lay the folded edges straight on a flat surface or cutting table.
- Fold the fabric at right angles and cut from selvedge.
- Mark the outline of the patterns using a tailor's chalk or red and blue pencil.
- Open layout is best for jersey fabrics irrespective of the type of the garment.

8.11.1.2 Silk

These fabrics are very thin, slippery and delicate. Great care is required in marking and cutting these fabrics. Pre shrinking is not required for silk fabrics. They can be used directly as purchased from the shops.

To straighten the fabric, lay them on the table and pull in cross wise direction. Lay the fabric on the flat smooth surface. Move fingers smoothly over the fabric to remove creases.

Place the pattern on the right side of the fabric. Right side can be identified

by seeing and feeling. The right side of the fabric is always brighter and smoother. Open layout is best suited this type of fabric especially for beginners.

8.11.2 Pattern Laying Based on Designs

Design incorporated in a fabric should be emphasized to enhance the personalities of the wearer. Hence pattern should be laid carefully to maintain the designs and to harmonize it with the basic silhouette.

● Bold designs

A large motif can be used for all type of garments, but they look best when they placed in irregular fashion.

If a fabric has too many motifs arranged in a crowded manner or a irregular pattern, they can be placed next to each other, cut and sewn.

When the material has been well designed with selvedge, large motif is repeated at equal distance, place these design onto the centre of the pattern. Do not cut through large motifs because it is difficult to match seam lines.

Pattern laying techniques vary based upon the design also.



Figure 8.9 Correct and Wrong Patterns with Bold designs

● One-Way Designs

One-way designs can be printed or woven in nature. Design goes in one direction. Example: Flowers on a creeper can be woven from selvedge to selvedge in

the lengthwise direction or a group of geometrical designs can be printed.

When patterns are laid on these types of fabric one must carefully check if the seam lines on one pattern match with the design of the pattern which is joined.



Figure 8.10 Correct and Wrong Pattern for Design Running from Top to Bottom



Figure 8.11 Correct and Wrong Pattern for Design Running from Left to Right

● Stripes and Plaids

Stripes are straight line running in lengthwise or crosswise direction. These stripes are called vertical stripes and horizontal stripes.

Stripes are most commonly used in shirt patterns. They can be cut in lengthwise and crosswise direction to create zigzag effects on garments.

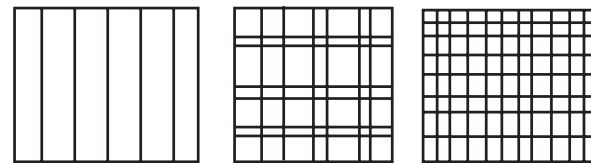

Figure 8.12 Stripes and Plaids Design

Collar, sleeves, Pocket patterns can be cut in cross grain on vertical striped material to create interest to the garment. Stripes and plaids can be even or balanced and uneven or unbalanced.

Even balanced stripes can be described as lines or bar arranged in a definite colour or placement.

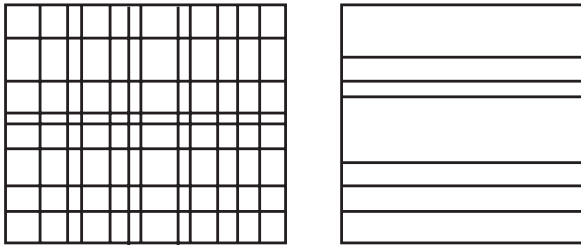

Figure 8.13 Even and Uneven Balance Stripes

● Border Designs

- These designs run along one selvedge only, they can be woven or printed.
- These designs can be used along the hem lines of the bodice, skirt and sleeve patterns.
- In order to maintain the design line some patterns like yokes and collars cut on straight grain. This fabric cannot be used for curved edged garments like flared skirts.
- One must make sure that the hem lines are straight to follow this design. While placing pattern on these designed fabrics, one must take care to match the designs.



Figure 8.14 Pattern for Zigzag and Abstract Designs

8.12 Principle of Economical Layout

- Never mark or cut any pattern until trial shows the best location for all pieces. Make temporary placements using small weights.
- Begin with the largest pattern pieces at the opposite ends of the fabric and work towards the centre to fit in smaller pieces.

- Place the wider ends of the pattern at the ends of the fabric. Cut notches outward if possible or inward if the material is not enough.
- Follow “Dovetailing” technique for pattern laying. Dovetailing is a placement of similar shaped patterns together. For example: A collar pattern can be placed closer to the armscye line. This will help one to save the fabric.
- In case the fabric is insufficient for the pattern, then a small piece of fabric can be added to the fabric, at the part where the pattern extends beyond the fabric. This technique is called piecing. Balance the pattern and add small bits on either side of the pattern, this will result in good drape.

8.13 Marking the Patterns

Introduction

Marking refers to the process of placing pattern pieces to maximize the number of patterns that can be cut out of a given piece of fabric in order to make garments. Pattern making is a highly skilled technique which calls for technical ability, sensitivity for design interpretation and a practical understanding of the process technology used by the factory. Marking is the process of transferring the pattern lines and details like darts on the fabric. It can be done using different methods like red and blue pencils, tailor chinks, pencil and carbon paper.

Points to be Considered While Marking

- To check whether all the pattern details are marked.

- To check if there is sufficient material for the garment.
- Select suitable method of marking E.g. Tailor's chalk for patterns with cutting lines only, Pencil and carbon paper to mark patterns for beginners, because sewing line can be marked.
- Do not mark using lead pen because it leaves black marks on the pattern.

Tailor's Chalk

- This is one of the easiest and simplest ways of transferring the pattern details on to the fabric.
- Tailor's chalk is a triangle coloured wax available in dark and light colours.
- The pattern is placed in the fabric and the outline is drawn using the chalk.

Pencil and Carbon Paper

- It is the oldest method of marking the patterns where carbon is placed in between the pattern and fabric.
- Then the pattern outline and details are drawn using an ordinary pencil.
- In this technique the sewing line and dart can be transferred.

Tracing Wheel

- A tracing wheel is also known as a pattern wheel, pounce wheel and dart wheel is an instrument with multiple teeth on a wheel attached to a handle. The teeth can be either serrated or smooth. It is used to transfer markings from sewing patterns onto the fabric with or without the use of tracing paper and can be used to make slotted perforations.
- Such markings might include pleats, darts, buttonholes, notches or placement lines for appliqués or pockets.

- The double tracing wheel has two parallel wheels that can be positioned a variable distance apart.
- This tool can be used to transfer parallel pattern lines onto the fabric, such as both the cutting line and the sewing line, where the distance between them is the seam allowance.

8.14 Cutting the Patterns

Cutting is the method of piecing the fabric into suitable sizes, so that it can be sewn together to form a full and neat garment.

Points to Consider

- Before actually start cutting into the fabric, make sure all the pattern pieces are laid out correctly and taken into account that some pieces may need to be cut out twice, or even four times (common with pockets and waistbands with interfacing).
- Extra fabric will need to be purchased when using prints that have a directional pattern, a print that needs to be matched (like with stripes and plaids), and fabric with a directional nap (like with velvet and corduroy). Pay close attention out pattern pieces on fabrics that have a direction.
- Make sure to use pins and scissors that are sharp. Dull pins can be damaging on more delicate fabrics, and sharp scissors make a big difference in the accuracy of cutting. Seams along corners and hemlines are cut in straight lines.
- Use rotary cutter and pattern weights. While cutting around pins. Not only is this method much faster, but it significantly reduces fraying while cutting.

8.15 Principles for Cutting

The main role of a cutting department is to cut garment components from fabric rolls or fabric as per style specifications. Then the cut components are goes to sewing department in bundles. A cutting department of a garment manufacturing unit includes following sub-processes.

- Fabric relaxation. Fabric spreading / layering on cutting table
- Marker making
- Cutting - manual cutting (using scissors), machine cutting and automatic cutting
- Numbering of garment plies (parts). Shorting and Bundling
- Inspection of cut components
- Shorting of printed and embroidery panels
- Re-cutting of panels. Fusing garment components

8.15.1 Factors to be Considered While Cutting Special Fabrics

- Precision in cut i.e. the dimension of pattern and fabric parts cut should be same
- The cut edge must be cleaned
- Infused edge
- Consistency in fabric cutting
- Support of lay
- Place the fabrics on the cutting surface. This can be a large flat table or counter
- Should position the pattern pieces on the fold or on the grain line as indicated
- Every pattern pieces have a front side i.e. printed side and back side

- If the fabric has a one-way design then lay all the pattern pieces in the same direction with finished project in mind
- Accurate notch size. If it is large in size, it can be seen after sewing of fabrics. Also there is a great probability of producing problems in matching of patterns after sewing
- Drill hole and size should be appropriate and it will be placed in its right place. If it is too large it would be seen after sewing. But if it is too small then it can be blocked easily

Cutting Specific Type of Fabric

- Cut faux fur from the back
- Use a rotary cutter to cut leather
- Dampen slippery fabrics before cutting them
- Place tissue behind delicate fabric, but aware that it can dull the scissors
- Take care to align prints, plaids and stripes when cutting patterns

8.16 Preserving the Patterns Before Sewing

The sewing pattern or the one that can be used commonly should be preserved. A favourite sewing pattern should be preserved so that it can be used over and over again without becoming distorted or ripped. Patterns can be expensive, and many become unavailable so preserving the pattern will be helpful. Preserve the patterns so that it can be used for a years.

Steps to Preserve a Sewing Pattern

- Press the pattern pieces so that there are no wrinkles in the pattern. It needs to be smooth so that the final piece will be as accurate as the original pattern.



- Lay the fusible interfacing on your ironing board (or ironing surface) with the fusible side up, the paper side or parchment paper on the ironing board side so that the fusible web does not fuse to the ironing board cover.
- Lay the pattern, right side up, on the interfacing, so that the interfacing will be fused to the wrong side of the paper pattern pieces.
- Place the pieces close together to prevent wasting the interfacing but do not overlap the pattern pieces. (Ignore laying the pattern out following the grain lines for preserving the pattern).
- Lay parchment paper on top of the pattern pieces and press the pieces to the interfacing, keeping everything flat and smooth.
- Cut out the pattern pieces, after the pieces are firmly fused together. Consider putting all the pieces in a large brown mailing envelope with the pattern envelope taped securely to the front and back of the brown envelope. Clear packing tape over the pattern envelope. Preserve the original envelope on the brown envelope.

8.17 Pattern Alteration

A comfortable, attractive garment fits properly. It is neither too large nor too small and conforms to the contours of the body without binding, pulling, sagging, straining or wrinkling. Fitting problems usually involve one or more of these basic body areas: neckline, bust line, hipline, arms, shoulder line, back waistline or abdomen.

Pattern adjustments and alterations are often necessary to achieve a good fit, especially in a form-fitting garment. Making adjustments or alterations before the garment is cut from the fabric will eliminate many problems later.

A Pattern can be Altered and Adjusted in Three Ways

- By folding out excess fullness
- By slashing and spreading or overlapping along pattern lines to increase or decrease dimensions.
- By redrawing darts or seam lines.

8.17.1 Standards for Pattern Alteration

Pattern Alteration Standards

- Original grain-lines are saved
- Patterns are kept in balance and proportion
- Change is created only in required point needed and is not obvious
- Designer's lines are protected

8.17.2 Basic Rules or Techniques of Pattern Alteration

- All similar pieces must be altered to correspond with the alterations on the major piece
- Additions or extensions must be made by taping an extension strip to the edge involved
- Altered patterns must have the same character as the original pattern piece
- Correct movement on altered pattern to give the altered line the same character as the original line
- The altered pattern must be properly flat, as like the original pattern piece





8.17.3 Basic Alterations

Altering the Length

If the garment is too short or too long can be able to lengthen or shorten the pattern before cutting the fabric. Usually one can make the alterations on the horizontal dashed lines marked on the patterns, such as elbow line, waistline or a hip line. On sleeves one can alter the length on the elbow line, on dresses on the waist and hip line and on trousers and skirts on the knee line.

Shortening a Pattern

- Measure the length of the pattern and take the same measurement on your body
- Compare the pattern measurements with individual measurements and calculate the difference
- Draw a horizontal line on the pattern at the level where it needed to be shortened (for example waist, hip, knee etc)
- Draw a parallel line just above periodically drawn line
- Cut the pattern into two parts from the lower line. Move and tape the lower piece straight up on the level of the upper line. Make sure that the centre front/back remains straight
- Draw the sides of the pattern smooth and continuous
- Check that seams that will be sewn together still have the same length

If the pattern gets shortened a lot, it is good to divide the difference into more than one line, for example on the waist and hip or hip and knee, in order to keep the proportions correct. It can be also measure the actual length from waist to

hip so that it is easy to calculate the length to be reduced

Lengthening a Pattern

- Measure the length of the pattern and take the same measurement of the body
- Compare the pattern measurements with individual body measurements and calculate the difference
- Draw a horizontal line on the pattern at the level where it has to be lengthened (for example waist, hip, knee etc)
- Cut the pattern into two parts through the lengthening line. Place a piece of paper under the pieces and tape the lower part on it
- Draw a parallel line on the paper, the required amount above the edge of the pattern
- Tape the edge of upper pattern piece on the line. Make sure that the center front/back remains straight
- Draw the sides of the pattern smooth and continuous
- Check that the seams that will be sewn together still have the same length.

Altering the Width of a Pattern

- Altering the Width of a Pattern from Seam
- Measure the length of the pattern and take the same measurement of the body
- Compare the pattern measurements with individual body measurements and calculate the difference. If the difference is significant width can be reduced or added from or to the waist darts, depending on the garment.



- Divide the difference evenly to all seams and mark the difference with a dot on each part has to be changed.
- Draw the outline of the pattern through the dot, adapting to the original shape.
- Check that the new line is not too steep or curved – in that case it will not fit properly after sewing. In case of improper fit allowance reduced or added can be from/to the waist darts.
- Check that seams that will be sewn together still have the same length.

Note that the patterns of slim garments that are made of elastic fabrics can be slightly smaller than actual body measurements.

Altering the Width of a Pattern from Waist Darts

- Measure the waist of the pattern and individual waist.
- Compare the pattern measurements with your own measurements and calculate the difference.
- Add or reduce the difference to/from all waist darts so that one can add or reduce the same amount from the side of each dart and draw new lines towards the tip of the dart.
- Check that the sides of darts are the same length and that the edge of the pattern continues smoothly over the darts.

Note that the darts should not be too wide. The back darts closest to center back should be wider than the other back darts – the width should not be more than 3-4 cm. Front darts should not be wider than 2,5 cm.

If there are two back darts, the darts closer to side seam can be left unsewn; this gives the waist more fullness. In this

case, draw the edge of the pattern smooth above the dart that you are not sewing.

8.17.4 Pattern Alteration for Centre Front and Centre Back

Points to be Considered

- Keep all fabric grain lines, the centre front, and the centre back on the fabrics straight of grain.
- Make adjustments carefully in order to preserve the garment's original style or design lines. Maintain ease allowance for comfort.
- Whenever possible, use adjustment lines already provided on a pattern. When you alter a pattern, make corresponding changes on all related pieces.

Full Bust (Large Cup Size)

Slash across the pattern along bust dart fold line to centre front. Slash across the pattern from waist to shoulder along waist dart fold line. Spread the desired amount at centre front and bust area. Do not spread at shoulder seam. Redraw seam lines and darts. (New darts will be larger than the original darts.)

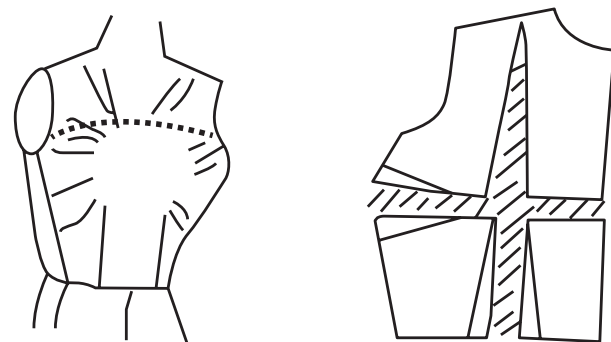

Figure 8.15 Pattern Alteration for Full Bust

Small Bust (Small Cup Size)

Slash across the pattern along bust dart fold line to centre front. Slash across

pattern from waist to shoulder along waist dart fold line. Overlap darts the desired amount to decrease the bust area. Do not overlap at shoulder seam. (New darts will be smaller than the original darts).

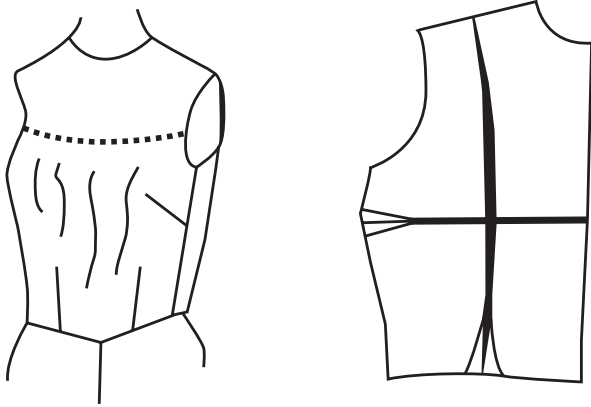

Figure 8.16 Pattern Alteration for Small Bust

Narrow Shoulders

Slash from midpoint of shoulder down and across to middle of armhole. Overlap pattern the desired amount, and redraw. Be sure to complete alterations for both bodice front and back.

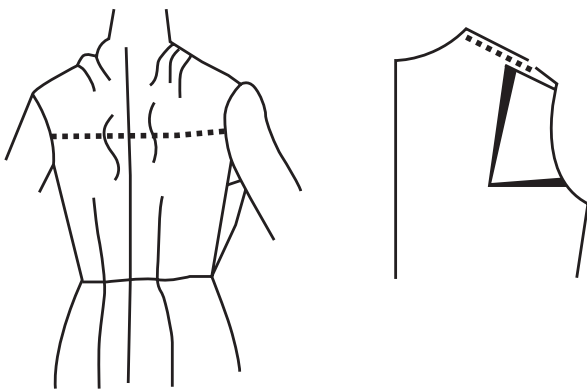

Figure 8.17 Pattern Alteration for Narrow Shoulder

Broad Shoulders

Slash from midpoint of shoulder down and across to the middle of armhole. Spread pattern the desired amount. Redraw seam from neckline to armhole. Be sure to complete alterations for both bodice front and back.

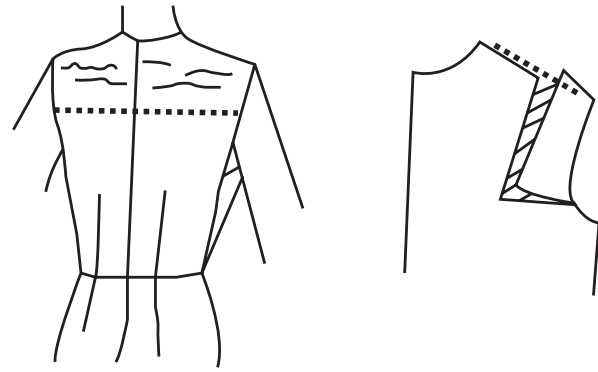

Figure 8.18 Pattern Alteration for Broad Shoulders

8.17.5 Principles of Pattern Alteration

- As far as possible make changes within a pattern by slashing and spreading or slashing and lapping. Patterns can also be altered by redrawing the edges of the pattern. (This is the method adopted for altering garments at the time of fitting.) But the first method is the best in altering paper patterns.
- To preserve the original grain line, make all slashes and folds parallel or perpendicular to the grain line (to centre front line, centre back line etc).
- Where there are darts, make changes between the tip of the dart and the outside edge.
- If an alteration in length is made along one edge of the pattern, take care to make an identical alteration in the adjoining edge. For example, if back shoulder seam is shortened the front shoulder seam should also be shortened.
- When tucks or darts are used for making a pattern smaller, remember that the width of these should be just half the amount to be removed.
- When decreasing or increasing the width of pattern pieces, if only half the pattern (half back or half front) is used, subtract or add only one fourth of the total adjustment to be

made. For example, if waist measurement has to be increased by one inch, add $\frac{1}{4}$ " to the half back pattern and the same amount to the front pattern. If only a front or back section needs adjustment, add or minus half the amount of the adjustment to the respective section.

- When the pattern alteration involves slashing and spreading, it is necessary to keep a sheet of paper beneath and to pin or stick to it the spread-out parts so that they will thereafter remain in position. On spreading or lapping after slashing, some edges of the pattern become jagged. These must be trimmed after drawing the new seam lines.

8.18 SUMMARY

Laying, Marking and Cutting are three very important aspects in garment construction, if it is done carefully, beautiful garments can be sewed to perfect fit in an economical manner. Marking refers to the process of placing pattern pieces to maximize the number of patterns that can be cut out of a given piece of fabric in order to make garments. Pattern making is a highly skilled technique which calls for design interpretation and a practical understanding of the process technology used by the factory.

POINTS TO REMEMBER

- Drafting and pattern making are the basic necessities for making fashion garment.
- Laying out your pattern on the fabric to prepare for cutting is an important step, that must be done carefully and accurately.
- Preparation of fabric for cutting and sewing involves the following steps: straightening, shrinking and pressing.
- Washable knits tend to shrink more often and to the greater degree than woven fabric.
- Laying, Marking and Cutting are three very important aspects in garment construction.

ACTIVITIES FOR TEACHER

- To show the procedure of the laying, marking and cutting.
- To make field trips to textile factories.

ACTIVITIES FOR STUDENTS

- To get to know more about given procedure.
- To get more practice by doing laying, marking and cutting.



INTERNET RESOURCES

https://www.youtube.com/watch?v=tbB61DJ6zgs	Lesson 3-12 - How to Lay, Pin, Mark and Cut the Fabric
https://www.youtube.com/watch?v=r4_3woAP9vw	Pattern layout, pinning, marking and cutting out - Marfy pattern 3022

A-Z
GLOSSARY

Geometric Design	A design based on a geometric pattern, often Contrasted with representational designs, such as floral or conversational.
Layout	An arrangement of motifs in a pattern, such as diamond, drop, gradation, grid, spot, and others. Also called repeat system.
Motif	One or many distinctive and recurring elements, forms, shapes, or figures that make up a design.
Pattern	A design for decorating a surface composed of a number of elements (motifs) arranged in a regular or formal manner. Often refers to “repeat pattern.”
Fabric Spreading	<i>Fabric spreading</i> means to <i>spread</i> the <i>fabric</i> in a systematic way. It is a process by which plies of <i>fabric</i> is spread in order to get required length and width as per marker dimension.

QUESTIONS AND ANSWERS

PART – I

Objective Questions

- In garment making, a _____ is the outline of a garment pattern in then traced onto fabric before cutting the fabric.
 - Design
 - Pattern
 - Motif
 - Layout
- The _____ for marking points at shoulder as armhole can be reduced or increased depending upon age or type of the figure of the individual.
 - Measurement
 - Draft
 - Cutting
 - Pattern
- _____ and pattern making are the basic necessities for making fashion garment.
 - Cutting
 - Marking
 - Layout
 - Drafting
- The _____ grain is composed of fabric threads that run parallel to the cut edges of the fabric.
 - Length wise
 - Cross wise
 - Selvedge
 - Parallel
- The interlooping of a single yarn is known as _____ fabric.
 - Woven
 - Knitted
 - Non-Woven
 - Rayon
- _____ is an arrangement of motifs in a pattern, such as diamond, drop, gradation, grid, spot, and others.
 - Design
 - Pattern
 - Layout
 - Dart
- Altered patterns must have the same character as the original _____ piece.
 - Marking
 - Cutting
 - Pattern
 - Drafting
- _____ is the method of piecing the fabric into suitable sizes, so that it can be sewn together to form a full and neat garment.
 - Cutting
 - Marking
 - Pattern
 - Drafting



9. _____ *spreading* means to *spread* the *fabric* in a systematic way.
- Pattern
 - Draft
 - Layout
 - Fabric
10. _____ design is based on a geometric pattern, often Contrasted with representational designs, such as floral or conversational.
- Floral
 - Geometric
 - Line
 - Shape

PART – II

Answer in Three (Or) Four Points

- What do you mean by laying a pattern?
- Describe in brief the types of layout.
- Give the importance of pressing?
- List the types of spreading?
- What is pattern alteration?
- How is Back bodice pattern prepared?
- What are the principles of Pattern laying?
- What do you mean by Fabric spreading?
- What is designing?

Answers for Objective Questions

- | | | | | |
|--------|--------|--------|--------|---------|
| 1. (b) | 2. (a) | 3. (d) | 4. (b) | 5. (b) |
| 6. (c) | 7. (c) | 8. (a) | 9. (d) | 10. (b) |

PART – III

Answer in a Paragraph

- How do you prepare a basic front bodice pattern?
- How do you prepare special fabrics for sewing? Explain.
- What are the principles of economic layout?
- Explain in brief on pattern marking.
- Give a brief note on fabric spreading.
- What is Pattern laying?
- How is a front bodice pattern been prepared?
- Explain the method of lengthening a bodice pattern
- Write about pattern laying based on one way designs.
- Explain briefly on pressing.

PART – IV

Answer in One Page

- How do you draft a back bodice pattern? Explain with a neat diagram.
- Write in detail about knitted fabric.
- Discuss about cutting and its principle.
- Explain in detail pattern alteration for full bust and small bust.
- Brief on pressing and drying fabrics.

Fashion Accessory and Ornamentation - Belts, Bows, Smocking and Traditional Embroidery

CHAPTER

9



LEARNING OBJECTIVES

- To identify different types of belts and bows suitable for fashion garments
- To understand the types of smocking
- To gain knowledge on traditional embroideries and ornamentation used on textiles.

9.1 Introduction

Fashion ornamentation is a type of decoration done on any textiles and garments to add aesthetic look. Designers include different types of embroidery and decorative work on fabric. Today's customer select garments that are surface enriched with decorative works. Moreover, the embroidered garments attract the buyers. Traditional embroidery found an important place in fashion arena. Especially Indian traditional embroidery has become popular all over the world. Each type of embroidery has its own unique way. Smocking is a surface ornamentation work. It gives

an extraordinary look to the children and women's wear garments. Belts are considered to be a fashion accessory. Belts are used as both functional and decorative accessory. Therefore it is essential to have thorough understanding about fashion accessories and ornamentation used in textiles and garments by the fashion designing students.

9.2 Belts

Belts are flexible band or strap of material worn round the waist over the garment usually to conceal the waist joint of bodice and skirt. The styles of belts go well with the design of the dress. Suitable material or contrasting colours can be used effectively to emphasise the belt. Belts enhance the look of the wearer. Selection of the size, shape, colour and type of the belt may vary from individual to individual. Belts may be made soft or stiff, narrow or wide, plain or intricate, depending upon the garment and the fashion trend. Stiffening used as a facing or interfacing keeps the belt in shape and gives it a tailored effect. Muslin, belting, cross grain ribbon or leather may be applied. The belt is mostly



fastened with a covered buckle or a novelty buckle. Faced, interfaced tie belts and skirt bands are cut in lengthwise grain, while sash belts are cut on the bias direction. Belts made from the same material of the garment serve both useful and decorative.

9.2.1 Types of Belts

- Soft belt
- Stiffened belt
- Shaped belt
- Interfaced belt
- Belt with backing
- Contour belt
- Inner belt

9.2.1.1 Soft Belt



Figure 9.1 Soft Belt

Soft waist belt is a fashion belt made of soft materials. These belts are used by woman folk along with western wear. Soft belts cinch the waist of the hour glass type figure and is ideal to wear over the over sized garments. These belts are adjustable, stylish and suitable for casual and formal wears.

Method of Construction

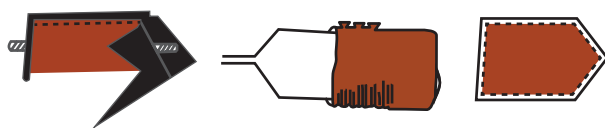

Figure 9.2 Steps in Construction of Soft Belt

- Take two lengths of belt pieces and a tape.
- Tack tape length to the right side of pointed end of the belt.
- Fix two sides of the belt in position right sides facing each other
- Machine around the belt starting from square edge
- Leave a small length unstitched near the square edge in order to pull the belt inside out
- Trim the pointed edge gently to avoid bulkiness when turned
- Drag one end of the tape and pull the belt inside out
- Remove the temporary tacking used to fix tape
- Press the unstitched seam edges to the wrong side at the square edge and press neatly
- Finish the square edges with slip stitch and complete the belt.

9.2.1.2 Stiffened Belt

The stiffened belt is one of the stable belts. These belts are cut on grain and are stiffened with interfacings. Stiffening material used in belt holds the belt in place. The stiffening materials are chosen based on the type of material used for the belt. Width of these belts is even and matched with garment styles.



Figure 9.3 Stiffened Belt



Method of Construction

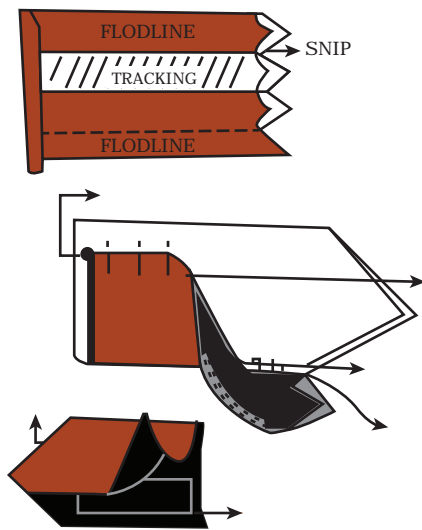

Figure 9.4 Steps in Construction of Stiffened Belt

- Take required length of material with seam allowance
- Cut the stiffening material to the finished width of the belt
- Mark fitting lines on the wrong side of the belt
- Place the stiffening piece to the fitting lines and sew
- Fold the seam allowance along top and bottom edges
- Fold the seam allowance of the square edges and press
- Trim the turnings of the sharp end on the wrong side of the fitting lines for flatness
- Pin and tack this in place, and slip-hem the bend into position
- Machine stitch in flat rows on the right side of the belt
- Fix a buckle to the square end if required.

9.2.1.3 Shaped Belt

The belts are shaped to create variety and beauty. Belt shapes are designed to match various garment styles and the wearer.



Figure 9.5 Shaped Belt

Method of Construction

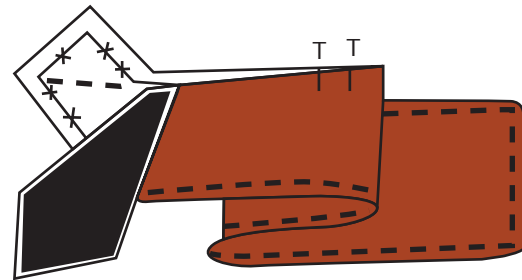

Figure 9.6 Construction of Shaped Belt

- To make shaped belt, first cut the interfacing of pre-shrunk canvas
- Use suitable weight of interfacing for stiffening the belt
- Pin the interface to the outer belt fabric
- Pin, rotate and baste the fabric edges over the interfacing
- Clip the curved edges if the belt is shaped
- Fold edges of the lining to the belt and stitch
- The belt may be edge stitched from the right side if needed

9.2.1.4 Interfaced Belt

The interfaced belt is the softest belt used for comfort. Folding over and becoming rope-like when worn are the disadvantages of this style of belt. From the fashion point of view, it is not the most desirable belt as many prefer stiff belts. One must be careful while selecting washable belts.



Figure 9.7 Interfaced Belt

Method of Construction

Figure 9.8 Steps in the Construction of Interfaced Belt

- Fold the belt pattern in half-lengthwise
- Cut the interfacing fabric exactly to the finished width of the belt
- Pin the interfacing to the wrong side of the belt
- Cut the belt edges evenly
- Catch stitch the long edge of interfacing to the center line of the belt
- Then fold the belt, half-lengthwise with right sides together and stitch along the edges of the belt to the pointed end.
- Cut off the corners and turn the belts right side out
- Turn the seam allowances and baste the finished edges
- Top stitch near the long edges if needed.
- Attach buckles and finish.

9.2.1.5 Belt with Backing

Belt with backing is a type of belt that gives a professional belt. This belt is constructed with backing material. This type of belt does not fold since it is backed with supportive backing material. Pre-shrinking has to be done if soft and ribbon like materials are used.

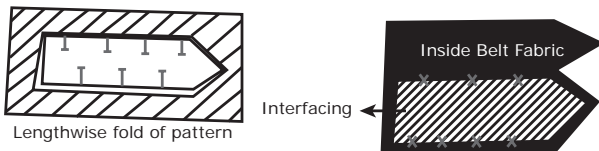

Figure 9.9 Belt with Backing

Method of Construction

Figure 9.10 Steps in Construction of Belt with Backing

- Cut a piece of backing material to the necessary length with an overlap of about 7 inches.
- Carefully shape one end of the belting as desired.
- Cut matching fabric in lengthwise grain for one inch wider and 1" longer than the belting
- Lap one edge of the belt fabric 1/2 inch over the belting and baste in place firmly.
- Hold the belt in a curved position
- Cover the fabric around the belting and keep it tight
- Pin it in place over the belting and sew the remaining edge in place





- Machine stitch $\frac{1}{4}$ inch away from the outer edges of the belt with longer stitches
- This belt is also made broader as waistbands and is suitable for many skirts.

9.2.1.6 Contour Belt

The contour belt is shaped to the body. It will hold the waistline perfectly and rest at the back. It is usually wider at the back and narrower at the front. The wider belts prominently show the contours or curved lines of the body. Narrow belts do not highlight the contours. This belt takes more time to make than the straight belt with belting as a backing.



Figure 9.11 Contour Belt

Method of Construction

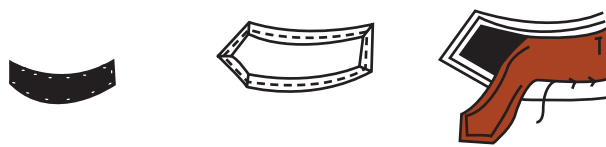

Figure 9.12 Steps in Construction of Contour Belt

- It is constructed by cutting an interfacing, facing and the stiff, in a cross grain to hold the belt correctly in position.
- Take the required length of belt material and fold into two
- Mark the on fold line as centre back
- From centre back to centre front mark side seam line point

- Mark a point between centre back and side seam line
- Also mark a point between centre front and side seam line
- Cut through the marked points and overlap the top side of the belt to properly fit the contour belt to the figure
- The belt is finished in a corresponding way as interfaced belts
- This belt is also made broader as waistbands.

9.2.1.7 Inner Belt Backing

Usually, the inner material is used for extra stiffness. The cross grain ribbon is cut and finished at the inner part of waistband which holds the skirt. The natural shape of the human figure is enriched by this belt.



Figure 9.13 Inner Belt Backing

Method of Construction



Figure 9.14 Steps in Construction of Inner Belt Backing

- Take required length of material with seam allowance
- Cut the stiffening material to the finished width of the belt
- Place the stiffening material in between belt material



- Fold the seam allowance along top and bottom edges
- Fold the seam allowance of the square edges on the wrong side and press
- Machine stitch in flat rows on the right side of the belt.



Who invented belt?

Belts as suspenders were used as back as 300 years back. Modern belts were first invented in 1820 by Albert Thurston.

9.2.3 Summary for Belts

Belts play an essential role in garments. It is an important fashion accessory worn with garments. There are different types of belt available in the market. Each and every type is designed for a specific purpose. Belts are constructed with numerous materials. Every belt is finished with buckle and eyelets. Bows are sometimes attached for design effect. Belts have its unique applications in its own way. They could be varied according to the pattern, purpose and the type of wearer.

9.3 Bows

Bow is a fashionable accessory used on garments. It is a common trimming found in hats. Bows add beauty and enhancement to the finished garments. These are made of fabric and used with buttons at times. They are usually added to girls and women garments. Wedding gowns, hats and party wear dresses are always designed with bows. Bows create a beautiful girlish look when worn.

9.3.1 Types of Bow

Bows are classified into three types based on the construction. They are as follows;

- Simple Bows
- Gathered Bows
- Ribbon Bows

9.3.1.1 Simple Bows

A simple bow is shaped like a butterfly. Sometimes it looks like a longer flowery bow. The wider the bow, the longer is the length required for tying the bow. Normally, the finished edges are wider than the middle part which is narrower. A wide finished width is required with turnings and neat finishing. This is one of the most attractive types of bow.



Figure 9.15 Simple Bow

Method of Construction

- Cut the fabric in cross grain and Fold the fabric in lengthwise pattern
- Shape as per the design
- Place the fabric right sides together and sew the ends
- Leave 5 cms (2 inches) unstitched at the center
- Trim the seam allowance to 0.6cm, slit corners and press seam lines neatly



- Turn the material inside out through the unstitched opening
- Slip stitch the unstitched opening
- Fold into half and mark the center point with a pin.
- Make a loop
Take the right loop in the right hand, left loop in the left hand and bend loops forward. Take right loop over the left loop and bring it out between the loops exactly at the pin marking
- Drag tightly until both the loops are even in size.

9.3.1.2 Gathered Bows

Simple bows with laces, embroidery or shirring create an excellent trimming for the plain garments. When the fabric is soft and needs a little stiffening, a layer of organdy or canvas can be used. Shapes can be created as desired.



Figure 9.16 Gathered Bow

Method of Construction

- Cut the fabric in cross grain and fold the fabric in lengthwise pattern
- Introduce gathers following the technique given below;
 - Run two or more lines of long stitches through the center line
 - Attach a thread elastic along the center line to gather

- Attach a lace or any trimming along the edges of fabric
- Sew the raw edges with a neat stitch
- Edges can be finished with a string of stones.

9.3.1.3 Ribbon Bows

Bows are made of ribbon, cords, lace or fabric tubing. These bows are placed at sleeves, pockets, yokes, collars, hem line, neck line and waist line for simple decoration. These types of bows are easy to make and are beautiful.



Figure 9.17 Ribbon Bow

Method of Construction

- Cut required length of ribbon
- Form two loops
- Adjust the length of the tails to equal length
- Take a left loop over the right loop and pull it gently
- Tack the position with invisible stitches and complete.

9.3.2 Summary for Bows

Bows add attention and variation to the garment. A simple garment is emphasised with a big bow. Children like belts and bows. This differs depending upon age, sex, and nationality. Usually children garment are designed with soft and silky bows. Bows are also made of various material and they add aesthetic look to the garment.



9.4 Smocking

Introduction

Smocking is an embroidery technique that is probably thousands of years old. The name is coined only during 1700's in England. The technique used at the time was gathering. A full work shirt was gathered at the bodice and the sleeves. This gathered effect in the garment was then called a "smock". Smocking was introduced to work man garment mainly to give fullness or free movement of their body and arms. Smocked garments were worn by agricultural laborers, trades men and shepherds in earlier times. In the 19th century smocks were received by artists, to cover their clothing and ladies adapted them in a modified form with fancy embroidery. Later babies clothing, silk under garments for ladies, and even afternoon dresses appeared with smocking. Ladies magazines had instructions for hand smocking and patterns for garments. At present smocking has become the fashion statement.

9.4.1 Types of Smocking

The industrial revolution changed the smocking styles and patterns drastically. There are many types of smocking known throughout the world. The Italians have shirring worked from the back of the fabric, the Romanians have a patterned design using tubes that resemble reeds and other countries stress picture formation over gathered threads done by hand. Smocking basically consists of pleated fabric and a fibre (usually a floss) for embellishment stitches. Pleats are created in two ways;

- A set of dots printed or pressed on the fabric.

- Dots are then used as a gathering guide to create hand pleats (Figure 9.9).

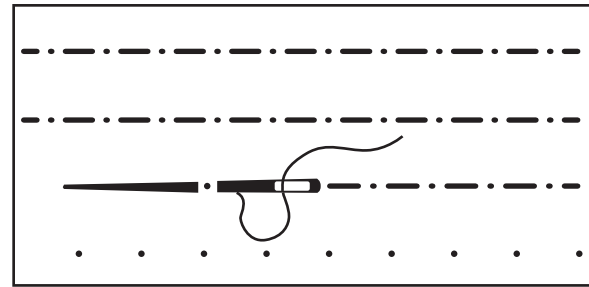

Figure 9.18 Dots Marked on Fabric

- Pleats used in English smocking look like small tubes (Figure 9.10).



Figure 9.19 Fabric tubing

- Small tubes are placed at equi-distant across a the fabric with a thread running through the tubes
- The threads running through the pleats are called as thread guides
- These thread guides are removed after the smocking is completed
- Thread guides should not be visible sometimes these stitches are not



removed at top and bottom lines to maintain shape.

Fabric Used

Silk, linen, cotton, striped and gingham fabrics are used. Firm fabrics are always preferred and are easier to embellish.

Outline stitch	
Cable stitch	
Trellis stitch	
Diamond stitch	
Feather stitch	
Honey comb stitch	

Wave stitch

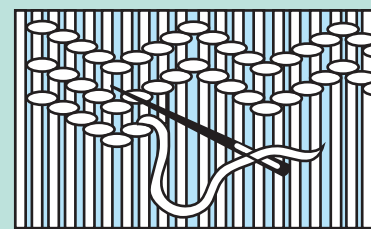

Figure 9.20 Smocking stitches

The gathering or embroidery techniques varied from area to area within a country. However smocking is categorised into three types such as English smocking, American smocking and Canadian smocking.

9.4.1.1 English Smocking

English Smocking is of two types namely **Geometric Smocking and Picture Smocking.**

● **Geometric Smocking**

In this type only two stitches are used. They are Cable stitch and Trellis stitch. Simple borders, lines and thousands of patterns can be created with cable and trellis stitches (Figure 9.21).

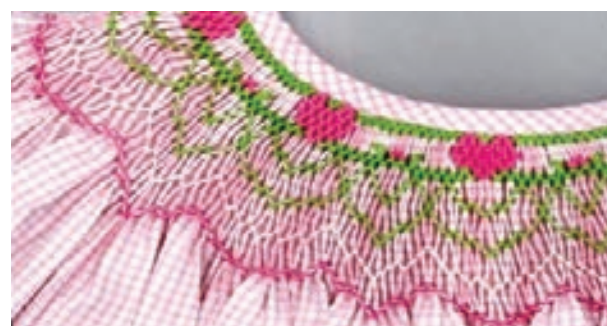

Figure 9.21. Geometric Smocking

● **Picture Smocking**

For picture smocking hundred percent cotton fabric is used. Fabric folds are secured very tightly. On the fabric folds,



embroidery is done with stacked cable stitches. Embroidered pattern should cover the fabric fully and the background fabric is not seen. Pictures such as flowers, animals, birds and other sceneries' can be created (Figure 9.22).



Figure 9.22 Picture Smocking

9.4.1.2 American Smocking

American Smocking is otherwise known as Counter change smocking. It has been popularized by a young woman in Arizona, Anne Hallay. This smocking is done on gingham, striped, or a gridded fabric. Basically 5/8" striped fabric is made into squares and a honeycomb or vandyke stitch is used to bring the sections together. Finished fabric will have the illusion of a solid fabric. No pleating is used for this type of smocking. This type of smocking is more often used in teenager's garments. English Smocking is of three types namely **Counter change Smocking**, **Mock Smocking** and **Direct Smocking**.

● Counter change Smocking

This type of smocking requires a grid. Most often striped and checked fabric is used to do this work. No stretch is created in this type of smocking. Three times more fabric is needed to bring to the required length and width.



Figure 9.23 Counter change Smocking

● Mock Smocking

For this type of smocking, fabric folds are created. Any printed or plain fabric can be used for this work. Little stretch is created in Mock smocking. Only honey comb pattern is created in mock smocking.

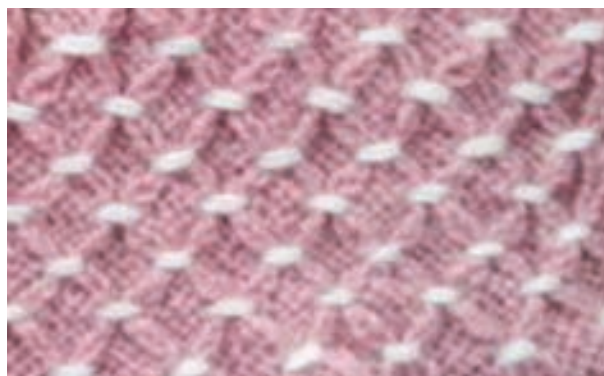

Figure 9.24 Counter change Smocking

● Direct Smocking

Grid pattern is used for this type of smocking. Following the pattern small stitches are made and secured. Trim the thread and complete the pattern.



Figure 9.25 Direct Smocking



9.4.1.3 Canadian Smocking or North American Smocking

Canadian smocking is also called as North American Smocking. In this type textural effect is created on the front side of the fabric. No pleating is required for Canadian smocking. A grid is drawn or designed on the back of the fabric. Later it is used to create the three dimensional effect on the front side of the fabric. This type of smocking is not usually pressed or ironed. The texture would be flattened or destroying if the smocked fabric is pressed.

The fabric used should be cut on grain

- Pleating threads are parallel to the cross grain
- Fabric is not damaged by the needles or the pleating machine
- There are no folds, bubbles, or splits
- Any temporary marking have been completely removed
- Smocking is appropriately centered in garment
- No visible break on the front side where the threads have been stopped and restarted
- Stitches catch only the appropriate pleats
- Stitch tension appears consistent for all stitches ;tension is neither too tight that pleats are pinched nor too loose so that thread sags
- Stitch depth is consistent
- Threads within stitches are laid smoothly
- Threads from any back smocking, are not visible on the front of the work

Types of Canadian Smocking

● Lattice Smocking

It creates a beautiful pattern on the right side of the fabric. There are a few variations where the pattern of stitches is worked on the front-one of these is called flower smocking. Grid pattern is used to mark designs.

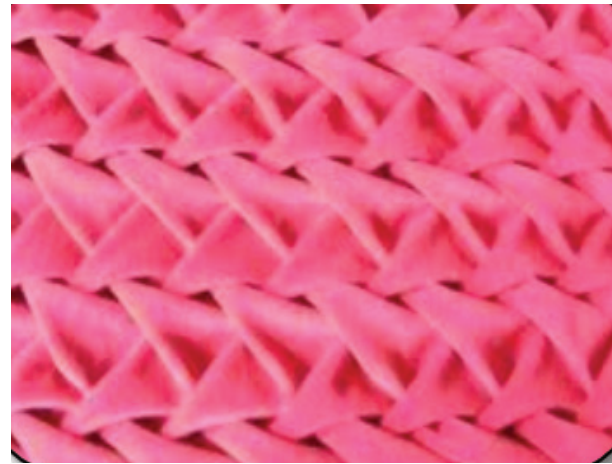

Figure 9.26 Direct Smocking

● Fabric Smocking

This smocking is created with the grid pattern. Textural effect is created on the right side of the fabric. Three times more fabric is required and good stretch is created.



Figure 9.27 Direct Smocking



● Reverse Smocking

This type of smocking is reversible. Patterns are seen on both the sides. No thread is visible on right and wrong sides of the fabric.

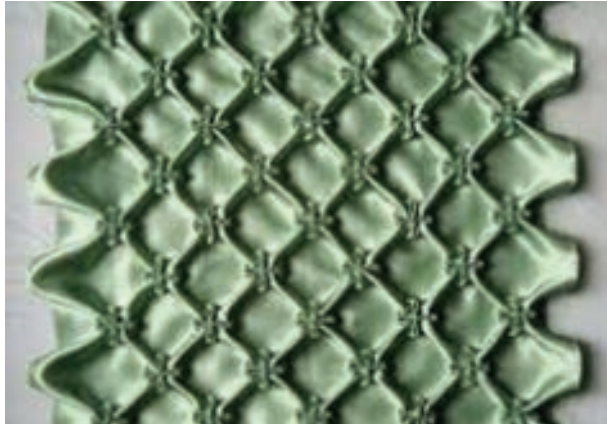

Figure 9.28 Reverse Smocking

Summary for Smocking

Smocking is a technique of creating wavy patterns on fabric and garments. Unlike embroidery more fabric is required for smocking. There are different techniques used to complete the pattern. Techniques and materials followed for each of the smocking type vary from region to region. English smocking, American smocking and Canadian smocking are the three types of smocking frequently used by the designers. Smocking is a common feature in girls and women garments. It also finds its application in home textile products such as cushions, wall hangings and so on. Today's contemporary designers introduce smocked fashion accessories in the market too.

9.5 Traditional Embroidery

Embroidery is one of the many great methods of applied decoration. But it requires good skill, time and artistic ability. Embroidery may be made by hand or machine. Traditional



Embroidery vary from region to region and are explained as follows;

9.5.1 Chikankari Embroidery

Region

Chikankari is whitework embroidery practiced in Lucknow, Uttar Pradesh. It is believed that Nur Jahan, wife of Mughal emperor Jahangir embroidered a cap for her husband, and hence familiarized this craft of white on white embroidery.

Technique

The embroidery is done on fine white cotton fabric with untwisted white cotton or silk thread. There are three types of stitches used in chikankari :

- flat stitches are made with stem stitch
- herringbone stitch is used for raised stitches like bullion and french knots
- pulled thread work or jali work is done

Motifs

The motifs are inspired by nature's flora including flowers, foliage, creepers, flowering stems, mango, almond, peacock, parrot etc.

Style of Embroidery

A common style present in each piece of Chikankari is the shadow work. To create a shaded effect, herringbone stitch is worked from the wrong side of the fabric. This creates a shadow of lighter colour on the right side. It imparts an outline to the motif on the right side. If worked from the right side of the fabric, double back stitch is used.

End Use

Traditionally the embroidery was done largely for male garments such as kurta, bandi, choga etc. for summer wear. Currently,

Chikankari is being used for apparel as well as home products. Embroidery is done on different fabrics like crepe silks, chiffons, georgettes, and cotton-polyester blends. Traditionally white on white embroidery on white fabric was common. Modern chikankari has a wider colour palette, from pastels to bright colours.



Figure 9.29 Chikankari Embroidery

9.5.2 Chambarumal Embroidery

Region

Chambarumal, is originated from Himachal Pradesh. It dates back to 15th century. There is a mention of this embroidery being practiced in Pathankot, Chamba and other remote villages of Himachal Pradesh in Buddhist literature and the Jataka Tales. Chamba was known for the most charming needlework, which the Romans described as 'needle painting'.

Technique

The embroidery is executed on two types of unbleached cotton cloth: lightweight,

delicate muslin or hand spun, hand-woven, coarser khaddar. Untwisted dyed silk threads in bright colours like red, yellow, green, blue, crimson and purple are used for the embroidery. The embroidery uses double satin stitch which simultaneously fills in the motif on both sides of the fabric. The embroidered fabric is reversible

Motifs

The motifs used are inspired by Pahari paintings depicting Lord Krishna and his playful antics. The embroidery also depicts the flora and fauna of the Himalayan region. Typical motifs include tiger, goat, deer, horse, peacock, parrot, flowers, shrubs and plants, willow and cypress trees; and musical instruments like sitar, tabla, veena, tampura etc.

Style of Embroidery

The embroidery is executed on a square piece of cloth. The motifs are arranged on the rumal in order to portray scenes from Lord Krishna's life. Some of the popular themes include Rasamandala, Rukmini Haran and Kaliyadaman. There are floral borders on all four sides of the rumal.

End Use

Traditionally the rumal was used as a case for food prasad offered to Gods and Goddesses. It was also a tradition to gift embroidered rumals at the time of weddings. Nowadays, the Chamba embroidery is made on fabrics like silk, polyester or terrycot and made into blouses, caps, slippers, cushions covers etc. Embroidered silk wall hangings are also exported from Himachal Pradesh.



Figure 9.30 Chambarumal Embroidery

9.5.3 Kantha Embroidery

Region

Kantha is an embroidery technique that originated in West Bengal. In the past, it was used to convert old used fabric into an embroidered textile.

Technique

The embroidery is executed on layers of old white cotton saris. Layers of cotton saris are stitched together with simple running stitch in white thread. The motifs are traced and embroidered using different

coloured threads also. The embroidery threads used are drawn from the old sari borders. The basic stitch used is running stitch along with satin stitch and chain stitch

Motifs

The motifs used in Kantha are lotus flowers, floral scrolls, tree of life, mandala, foliage, creepers, animal and bird forms; fish, sunrise, mermaids, ships, submarine scenes; domestic articles like mirrors, pitcher, nutcracker, umbrella, musical instruments and human figures like gods and goddesses, horseman, fisherwoman etc. The designs of folk stories, epics, mythological background, ritualistic motifs, animals, dancing peacock, temples, are also different types of costumes.

Lotus is the most common and important motif widely used in Kantha. 'Kalka' is another important motif a cone mango shaped.

Style of Embroidery

Different embroidery layouts are followed in Kantha. Some examples are; central motif and tree of life on all four corners, arrangement of motifs in panels or a big central panel and placement of smaller motifs all over the textiles



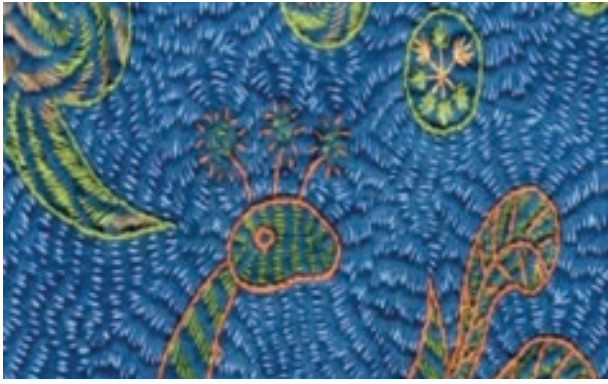

Figure 9.31 Kantha Embroidery

End Use

Kanthas were largely used as quilts. It is offered to special guests to sit or sleep on it. It was conferred to the bride and groom. It is also used to wrap valuables and gifts. Other uses of Kantha are bags which are used for keeping money and also used as book cover. Nowadays, Kantha embroidery is done on a single layer of white or coloured fabric base using contemporary motifs. Other products made with Kantha embroidery are stoles, dupattas, saris, and suit materials.



Origin of Kantha embroidery.

Kantha is one of the oldest forms of embroidery that originated in West Bengal, India. Its origins can be traced back to the ancient pre Vedic ages. Kantha embroidery was found in Krishnadas Kaviraj's 500 year old book, Chaitanya Charitamrita.



9.5.4 Kathi Embroidery

Region

Kathi Embroidery, Kathibharat or Kathipa style of embroidery is practiced by the Kathi community tribal women of Gujarat. Black colour fabric is used as the base fabric. Stitched Kathipa style of embroidery is otherwise known as 'heer'.

Technique

Repeating patterns of six to eight-pointed stars, triangles and squares are arranged to form a beautiful design. Outlining is done with darning stitches and the fillings are covered with herringbone stitches. Mirrors are attached with buttonhole stitches to form squares and triangles.

Motifs

Motifs such as humans, animals and birds along with landscape forms are used in this embroidery. Bold motifs with mirrors create a colourful depiction in dark blue, orange, purple, indigo, black, deep red with little tints of yellow and green.

Style of Embroidery

Embossed designs are done all over the fabric. Geometric patterns are created between borders constructing chequered forms. Long stitches along with herringbone stitches and contrasting colours define the design vocabulary of Kathibharat. Small mirrors are stitched to add beauty to the embroidery. The stitches in triangles run in parallel to the warp and weft creating an interesting effect. Single colour silk floss with light and dark shades is often used.

End Use

The traditional attire of Kathi women become an intrinsic part of costumes worn by both rural and urban women

during Navratri. Besides the garments, Kathipabharat is also used in creating a range of home adorning textiles like chaklas, torans or textile door frames, cushion covers and mats.



Figure 9.32 Kathi Embroidery

9.5.5 Kasuti Embroidery

Region

Kasuti embroidery is practiced in Karnataka. This is a promising craft produced by women. In early times, every bride would own a silk sari with Kasuti embroidery done on it.

Technique

The embroidery is done on a hand-woven cloth of darker colours. Cotton threads in different colours like red, orange, purple, green, yellow and blue are used. The embroidery threads used are drawn from the old silk sari borders.

Four Basic Stitches used are;

- i. Gavanti - double running stitch that creates the same effect on both sides of fabric
- ii. Murgi - zigzag running stitch that works in a stepwise manner
- iii. Negi - simple running stitch that produces a weave-like effect, and
- iv. Menthi - cross stitch that gives a heavier appearance.

Motifs

The motifs are inspired by religion, architecture, flora and fauna, and objects of daily use. Some examples are star-shaped designs, chariot, and palanquin for deity, tulsi pot holder, cradle, sacred bull, deer, elephant, peacock, horse, and lotus

Style of Embroidery

The embroidery uses a combination of horizontal, vertical and diagonal stitches. The motifs are not traced on the fabric and the embroidery is done by counting the yarns on the base material.

End Use

Traditionally the embroidery was made on Ikhat sari and other apparel items like women's blouse and children's bonnets. Presently Kasuti embroidery is also made on home products like cushion covers, bedcovers, curtains and accessories like handbags, mobile pouches, belts etc.



Figure 9.33 Kasuti Embroidery

9.5.6 Kashmiri Embroidery (Kashida)

Region

Kashida is embroidery originated from Kashmir. It is practiced by menfolk of the region. The elaborate needlework is inspired by the charming natural surroundings of Kashmir.

Technique

The base material for Kashida is cotton. Wool or silk fabric in a variety of colours like white, blue, yellow, purple, red, green and black are also used. The embroidery threads used are wool, silk or cotton depending on the product to be embroidered. The main stitches employed for Kashida are darning stitch, stem stitch, satin stitch and chain stitch.

Motifs

The motifs used in Kashida depict the natural elements which include the rich flora and fauna of the region of Kashmir. Typical motifs are birds, flowers, butterflies, maple leaves, almonds, cherries, grapes and plums. A popular motif seen on embroidered shawl is the cypress cone.

Style of Embroidery

There are three styles of embroidery followed in Kashmir; (i) Sozni is intricate embroidery that uses stitches like a fly stitch, stem stitch and darning stitch. (ii) aari style, also called Zalakdozi employs hook or aari to fill-in motifs with chain stitch. (iii) Kashmiri couching, zarithread is laid on the fabric along a pattern and is held in place with another thread

End Use

Kashmiri embroidery is primarily done on shawls and regional garments like Phiran. Chain stitch embroidery is made on woollen floor rugs called Gabbas and Namdas. Nowadays, Kashida is also used to enhance household items like bed covers, cushion covers, lampshades, bags and other accessories.



Figure 9.34 Kashidha Embroidery



Figure 9.34 (Continued)

9.5.7 Phulkari

Region

Phulkari is an embroidery style that is originated in Punjab. The earliest possible article of phulkari embroidery is a rumal embroidered during 15th century by Bibi Nanaki, sister of guru Nanak dev. The needlework is widely practiced by the women of Punjab. It carries significance in the life of a woman, from her marriage until her final abode to heaven.

Technique

The base material to execute Phulkari is handspun and handwoven Khaddar that is dyed in red, rust, brown, blue and darker shades. Soft untwisted silk thread 'Pat' is used for the embroidery. The colours of the thread are red, green, golden yellow, orange, blue etc. The basic stitch employed for Phulkari is a darning stitch, which is done from the wrong side of the fabric. The stitches follow the weave and a beautiful effect is created on the fabric by changing the direction of the stitches. For outlining of motifs and borders, stem, chain and herringbone stitches are used.

Motifs

The motifs used in Phulkari are inspired by objects of everyday use like rolling pin, sword, flowers, vegetables, birds, animals etc. They are generally geometrical and stylized. Usually, one motif is left unembroidered or is embroidered. This motif is called 'nazarbuti' which is considered to ward off the evil eye.

Style of Embroidery

The two embroidery styles prevalent in Punjab are Bagh and Phulkari. Bagh is a fully embroidered wrap that is used for special occasions whereas Phulkari is simple and lightly embroidered for everyday use

End Use

Phulkari is an essential part of the bridal clothes and is worn as a veil or wrap by women on special occasions. A specific pattern of Phulkari is also used as the canopy on religious occasions. Presently, Phulkari is being done on bed linen and apparel like tops, tunics, and skirts.



Figure 9.35 Phulkari Embroidery

9.5.8 Dori Work

Region

Dori embroidery is basically a cord or a strong thread. This work is stated to be the Cro Magnon Era.

Technique

It is used to fill up the petals of a flower or leaves. The applique is fixed with chain stitch or Dori work to give it a dimensional effect. It is the tasselled or frilled border for decoration.

Motifs

It can be crafted in a floral pattern radiated all over the attire or having double work border. It is a unique decorative lace, which is frequently available with fine silver, metallic and golden lines.

Style of Work

This art is related to applique embroidery. Woven fabric either gold or silver is fixed onto the other fabric to create different surface textures. Various colours of cords are used for the embellishment of

the fabric. Couching stitches and some stitches of zardozi are used. Matching colours of the cord can be used to make couching of the cord invisible. It is usually combined with sequins and pearls to form a mesmerizing effect.

End Use

Lehanga, salwar kameez, kurtis, bags, purses, shoes, blankets, caps, and blouses are worked with cords. This art work gives a rich look to the garments.

9.5.9 Gota Work

Region

Gota work was patronized by the Mughals. This work was spread to the courts of Jaipur and Jodhpur. The embroiderers of Jaipur, Bikaner, Ajmer, Udaipur and Kota are world famous for their uniquely styled gota work. Gota Patti work is also known as Aaritari or zardozi. Moghals and Rajputs royals used to wear the clothes worked with Gota Patti.

Technique

Gota work is done with a strip of gold or silver ribbon. Kasab or ribbon is drawn under a calendar to give it a flattened effect called as "Badla". For custom made garments, the base metal used is copper coated by silver etc. The Gota Patti ribbon is cut, folded and patched over fabric. The other materials used are dory, beads, sequins, stones etc. The base fabrics used for Gota Patti work are lightweight chiffon, georgette, satin solid dyed or printed fabrics. Awe or Aari needle is used for this method.

Motifs

The design and motifs are inspired by nature like birds (peacock, parrot, sparrow), human figure (BaniThani),



Figure 9.36 Dori Work

animals (elephant, horse). The modern design like paisley, geometrical, palanquin, checker board are also in fashion. These motifs are structured into buta, butties and cut into different shapes like flower pot (Gamla), Keri (Mango) and champak flower, and stitched with the base fabrics by chain stitch or by hemming.

Style of Work

Badla was prepared by mixing 100 grams of silver and 10 grams of gold. The mixture is hammered into thin sheets and cut into very fine strips. In recent years pure yarns are replaced by synthetic yarns. The colours commonly used are red, orange, pink, magenta, maroon and yellow which are nowadays available in all possible shades as per the customer demand.

End Use

Edging of sarees, dupattas, ghagras, lehanga cholis, kurtas, bed spreads, cushion covers, clutches, shoes, rugs, upholstery, anarkali suits, bags, stoles and scarfs.



Figure 9.37 Dori work

9.5.10 Thread Work

Region

History of thread work dates back to Cro-Magnon days or 30,000 BC. During archaeological findings heavy worked clothing's were found. Chinese thread embroidery work dates back to 3500 B.C. For thread work, natural yarns and fabrics have been used since time immemorial.

Technique

Thread embroidery is the decoration of a wide variety of materials and thread, for example; cotton, silk, wool, gold and silver wires. The work can be done on a frame or in the hand. There are various kinds of stitches used are such as chain, satin, long and short, French Knot, interlacing, herringbone, running, stem and back stitch etc.

Motifs

Naturalistic, geometric, abstract, historical and conventional motifs are extensively used.

Style of Work

There are two varieties of thread work embroidery namely surface embroidery and counted thread embroidery. In surface embroidery, the pattern is formed using decorative stitches. Thread is laid on top of the foundation fabric rather than through the fabric. In counted thread embroidery, the fabric threads are counted and then the needle is inserted into the fabric.

End Use

Textile materials and garments, various garments such as kurtis, salwar kameez, skirts, blouses, skirts are worked with thread embroidery.



Figure 9.38 Surface Thread work



Figure 9.39 Counted Thread work

9.5.11 Summary

Traditional embroideries are unique and give a sense of beauty to the garments. In India, each state has its own traditional embroidery and is practised even today. Most of the designers inspire from these embroideries and create textile patterns. All the branded items sold in today's

market are enriched with any one of these traditional work. Fashion designers who learn and understand each and every work would be successful.



What is Banjara Embroidery?

The nomadic tribes or the Banjaras were wandering groups. They did not limit themselves with the boundaries and binds of the urban life.

Lambani or Banjara embroidery is a combination of colourful threads, design patters, mirror work, stitching patterns appliqué or patch work



POINTS TO REMEMBER

- Belts - Flexible band or strap of material worn round the waist
- Contour belt - Belt that is shaped to the body curves
- Bow - A fashionable accessory used on garments and accessories
- Picture Smocking - Embroidery is done with stacked cable stitches on fabric folds
- Chambarumal - Traditional embroidery of Himachal Pradesh
- Chikankari - Traditional embroidery of Lucknow
- Kantha - Traditional embroidery of West Bengal
- Kashida - Traditional embroidery of Kashmir
- Kasuti - Traditional embroidery of Karnataka
- Phulkari - Traditional embroidery of Punjab
- Gota work - It is done with a strip of gold or silver ribbon
- Dori work - It is an embroidery work done with a cord or a strong thread

ACTIVITIES FOR TEACHER

- To show different images for various belts, bows and surface ornamentation items.
- To take students to boutiques in shopping malls to explain various fashion accessories and ornamentation

ACTIVITIES FOR STUDENTS

- To collect images and prepare scrap book for belts, bows and smocking
- To make different types of bow with fabric scrap
- To gather fabric scrapes with embroidery and display



INTERNET RESOURCES

https://mellysews.com/2012/05/smocking-tutorial.html	Techniques of smocking
https://www.youtube.com/watch?v=-fcN2FFVXo4	Making a simple bow
https://www.craftsvilla.com/blog/famous-indian-embroidery-styles/	Indian embroideries
https://hubpages.com/style/types-of-fashion-accessories	Types of fashion accessories



GLOSSARY

Contour belt	Belt that is shaped to body waist
Canadian smocking	Lattice smocking
Chikankari Embroidery	Shadow work
Dori embroidery	Cord or a strong thread work
Gamla	Flower pot
Gavanti	Double running stitch
Gossamer delicacy	Superfine and delicate materia
Intricate	Complicated
Kantha	Embroidery of West Bengal
Kashida	Embroidery of Kashmi
Kathibharat	Embossed designs
Novelty Buckle	Small and inexpensive toy or ornament
Pre-Shrunk	Shrinking process during manufacturing to prevent further shrinking
Smocking	Gathering a full work shirt at the bodice or sleeve
Traditional gota work	Silver and gold ribbon work

QUESTIONS AND ANSWERS



PART – I

Objective Questions

- Which belt is cut in bias?
 - Tie
 - Faced
 - Skirt
 - Sash
- This is used as buttons sometimes.
 - Belt
 - Bows
 - Faced
 - Tie
- Work done by pulling certain amount of material together.
 - Bows
 - Belt
 - Embroidery
 - Smocking
- An example for applied decoration.
 - Applique
 - Printing
 - Embroidery
 - Sequence
- This is also known as shadow work.
 - Thread work
 - Chickankary
 - Kutch work
 - Dori work

PART – II**Answer in Three (Or) Four Points**

1. What are bows?
2. What is contour belt?
3. How will you make a simple bow?
4. What is smocking?
5. Indicate the features of Canadian smocking?
6. Define embroidery.
7. List out the traditional embroidery.
8. Name the motifs used in Phulkari.
9. Mention the techniques involved in Kantha embroidery.
10. State the method of doing Kashidha work.

PART – III**Answer in a Paragraph**

1. Explain stiffened belt with a neat illustration?
2. Write down the sewing procedure for inter faced belt.

3. Write short note on English smocking.
4. Classify bows and Illustrate.
5. How is Gota work done?
6. Differentiate between Dori work and Gota work.
7. What is thread work embroidery? Give examples.

PART – IV**Answer in One Page**

1. Describe the types of belts with illustration.
2. Classify bows and explain the method of preparing bows.
3. Give an account on the types of smocking.
4. Briefly explain the different types of traditional embroidery.

Answers for Objective Questions

1. d) 2. b) 3. d) 4. c) 5. b)

Selection of Fabric for Construction of Garments

CHAPTER

10



LEARNING OBJECTIVES

- To gain knowledge about the various textiles and their properties
- To understand the selection of suitable fabric for garments

Good fabric helps in enhancing comfort, good design and the personality of the wearer. Fabric is selected according to factors like age, climate, sex, nationality, purpose of the garment, occasion, activities of the wearer, availability of the fabric in the market, design of the garment and current fashion.

10.1 Introduction

This chapter is all about understanding different types of fabric for construction of different garments. Well fitted, comfortable garments in harmonious colour to accent eyes, attractively arranged, contributes a feeling of well-being and self-confidence. An appropriate costume ensemble of this type will help to develop the well-poised, personal individual who is ready to participate in group activity or to work alone with confidence.

In dressmaking and designing, fabric selection is vital and an integral part. Different fabrics are required for different ages, purposes and occasions. Wedding dress, uniform, undergarments, casual wear, all require a different kind of fabrics and at times of combination of many.

10.2 Common Fabrics Used for Garment Construction

10.2.1 Cotton

Cotton is a lightweight, semi-sheer fabric, slightly crisper. Cotton clothing can be worn around the clock. A single cotton fabric, pique, can be used for home wear dress, a sports dress, a summer business dress, a bathing suit, or a beach bag. It is particularly adapted to children dresses. Cotton is then appropriate for wearing apparel, home furnishings, industrial uses, and military supplies.

10.2.2 Silk

Light weight and delicate silk drapes well. It has a slight slippery appearance. Silk can be slippery and more difficult to work



with this fabric. It also makes a great lining fabric. Pure silk retain their shape better than rayon or acetate. They can be packed in small spaces; in dark colours they do not show dirt; wrinkles and crepe will hangout especially well. Spun silk is suitable for knit goods such as, sweaters and hosiery.

10.2.3 Wool

There are more than 200 different types of wool, obtained from 40 different breeds of sheep. Wool is extremely hard-wearing and versatile. It also keeps us warm. Woollen fabrics are made in different weights, from the filmiest sheer veiling to the heaviest over coating. Sheer fabrics such as wool georgette, voile, featherweight tweeds, lightweight crepes, and some sheer wool meshes, can be worn comfortably.

10.2.4 Nylon

Nylon is a synthetic and manmade fibre. Nylon fabric is strong and light in weight. It can be washed easily and is dried quickly. It has a great strength, abrasion resistance, and stability in washing and wearing. A nylon-rayon blend makes a fine-count, strong yarn for light weight washable fabrics. When nylon and cotton are blended, nylon again contributes to its strength, abrasion resistance, and dimensional stability.

10.2.5 Rayon

Rayon is a semi synthetic material which is made from cotton linters or from the soft tissues of trees such as spruce. Its properties are similar to cotton fabric. Rayon can be worn at all hours of the day: for sleeping, sports, business, street, afternoon tea, cocktails, dinner, and

evening wear. They are used in home furnishings, too.

10.2.6 Cotton / Polyester Blends

In this type of fabric, cotton fibres and polyester fibres are mixed in desired proportions. These fabrics are breathable, tear- resistant. They are light in weight. They are also more comfortable to wear.

10.2.7 Silk Cotton

This is a blend of silk and cotton fibre. They are lightweight, silky and soft fabric which is used in stitching of wide range of garments. The properties of this type of fabric are a mixture to the properties of cotton and silk fabrics.

10.2.8 Linen

Medium-weight with little elasticity fabrics made of linen are cooler. Linen conducts heat very well, so it is a popular choice for warm weather. It is chiefly used for comfort in summer apparels, sheets, and summer coverings for wool upholstery.

10.2.9 Satin

Satin is a sleek and glossy fabric created with a particular type of textile weave, during the process woven material is run through hot cylinders. The fibres that are commonly woven to create satin are silk, cotton, wool and also synthetic materials like polyester or acetate that allow to have a less expensive fabric. Satin can vary from light weight to heavy weight, depending on the type. Like silk, it has a glossy appearance.

10.2.10 Flannel

Flannelette is a light to medium weight cotton fabric that was originally woven



in imitation of wool flannel. It is napped only on one side and made of lightweight fibres. Both flannel and flannelette can be woven in plain weave and twill weave. Flannel is the mostly used for colder-temperature shirt, pants and jackets.

10.2.11 Denim

Denim is a heavy weight fabric with very little drape or stretch. Denim fabrics are normally used for making **jeans**, work clothes as well as casings for pillows.

10.2.12 Knit

Several types of knit are available from light weight to medium weight. Knits are mostly used for the garment where stretch is needed. It is comfortable and breathable and comes in a variety of weights and designs, and it is renowned for standing up to physical activity.

10.2.13 Double Gauze

This unique fabric is literally two layers of gauze woven together. The double layer of fabric solves the main problem of sewing the gauze (the sheerness), while retaining the good quality (extremely light and breathable).

10.3 Materials Suitable for Infants Garment

Baby skin is very sensitive. Clothes must be soft and pliable to be really comfortable. Hence soft, knitted fabrics are popular. Cotton fabrics are suited for babies. Babies clothing should be easy to launder, and is durable. The garment should be comfortable and allow movement. It should be of designed growth and development of muscles. Commonly used garments for infants are,

10.3.1 Jabla

It is a simple shirt and a suitable fabric to construct jabla. Woven or knitted cotton fabric

Suitable colour: white, pink, blue, yellow, green, purple and orange.

Suitable design: small printed motifs.

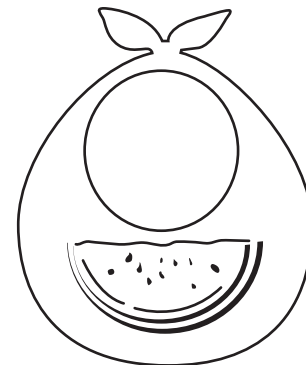

Figure 10.1 Jabla

10.3.2 Bib

Bib is wrapped around the neck, so that it protects the baby clothing from food spills, moisture and soil. Any absorbent material can be used.

Suitable fabric : cotton, flannel, terry, cotton knit.

Suitable colour : white, pink, blue, yellow, orange, green, purple.

Suitable design : plain, quilted, small printed motifs, embroidered.

DO YOU KNOW? Why is a bib called a “bib” ?

A Bib is a small piece of fabric that's tied under a babies chin to keep food (or) milk from staining her/his clothes

A baby's bib is just one type — there is also the bib that makes up the top part of overalls or an apron, the section that covers the chest. Sometimes the corresponding part of a bird's body, a patch of colour on the chest, is also called a bib. The word stems from the now-obsolete verb bibben, “to drink,” which is thought to be imitative of the sound your lips make as they sip liquid.



10.3.3 Bonnet

Bonnet is the simple caps that are worn on the head to regulate the temperature. The head and ears are specially protected from the sudden change in temperature. In warm weather, bonnet should protect from sun's rays.

Suitable fabric: cotton (both woven and knitted), wool (both woven and knitted).

Suitable colour: white, pink, blue, yellow, purple, orange, green.

Suitable design: plain, printed small motifs.

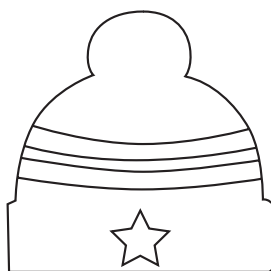

Figure 10.2 Bonnet

10.3.4 Knicker

Knicker is a simple short used to cover bottom part of the body.

Suitable fabric: cotton (both woven and knitted).

Suitable colour: white, pink, blue, yellow, purple, orange, green.

Suitable design: plain, printed small motifs, stripe, checked.

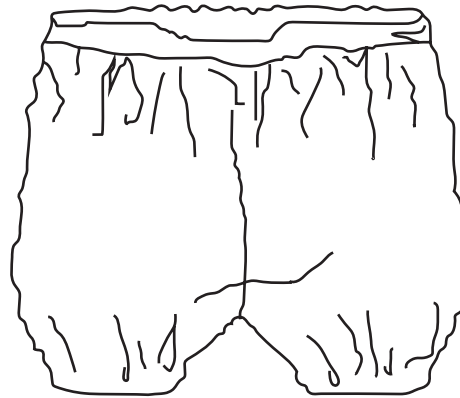

Figure 10.3 Knicker

10.3.5 Panty

It is a basic garment worn on the bottom part of the body to hold the diaper.

Suitable fabric: cotton (both woven and knitted), satin for party wear.

Suitable colour: white, pink, blue, yellow, purple, orange, green.

Suitable design: plain, printed small motifs.



Figure 10.4 Panty

10.4 Material Suitable for Children Garment

From first to 11 years, children grow very fast and they are very active. They are classified as pre-schoolers, primary school kids and elementary school children. These kids prefer bright coloured, comfortable fabric. As these group kids are fast growing, deep hems and wider seam allowance are commonly advisable. Commonly used garments for children's are as follows :

10.4.1 Sun Suit / Rompers

This is a single piece suit with combination of shirt and short. Rompers should be designed in such a way that it can be slipped off easily and quickly. To facilitate the changing of diapers, the lower back of the romper can be extended and shaped so that it can be pulled up between the legs and buttoned well over the front.

Suitable fabric: woven cotton, knitted, denim

Suitable colour: light shades, blue, grey, brown, green

Suitable design: stripes, checks, small flowers, geometric motifs, and cartoon designs.

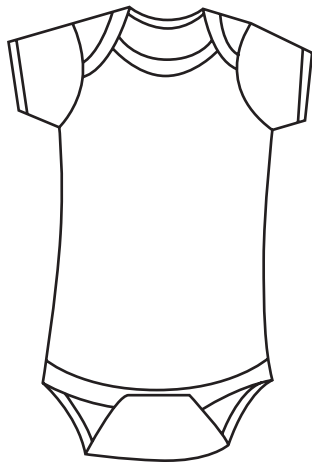

Figure 10.5 Romper

10.4.2 Baby Frock and its variations

Frocks are mostly worn by little girls. They are mostly of knee length. It is comfortable and loosely fitted garment.

Suitable fabric: casual wear: cotton, synthetic fabric, denim blended fabrics.

Party wear: silk, synthetic, velvet, net fabrics

Suitable colour: white, pink, blue, yellow, orange, green, purple, fluorescent, navy blue.

Suitable design: plain, quilted, printed motifs, striped, checked, surface enrichment.

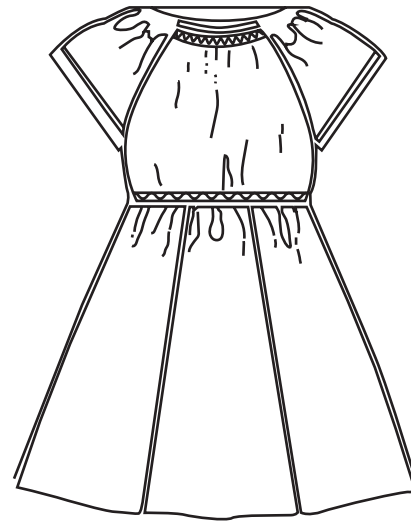

Figure 10.6 Baby Frock

10.4.3 Pant / Shorts

A basic garment worn from waist to knee or waist to ankle with two legs joined at crotch.

Suitable fabric: cotton, denim, blended fabrics

Suitable colour: navy blue, black, blue, brown, grey, bottle green.

Suitable design: checked & plaids, plain, small motifs.

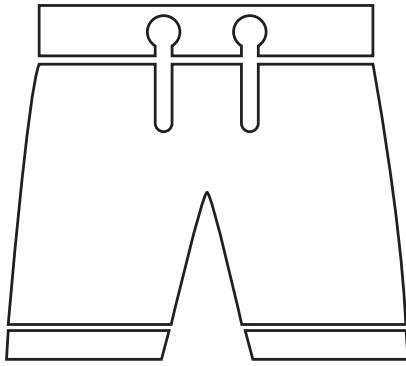

Figure 10.7 Shorts

10.4.4 Shirts

Shirt is a loose garment for the upper part of the body. This can be worn by both boy and girl.

Suitable fabric: cotton, blended fabric, denim, linen.

Suitable colour: white, brown, grey, blue, green.

Suitable design: floral, abstract motif, geometric, embroidery design.

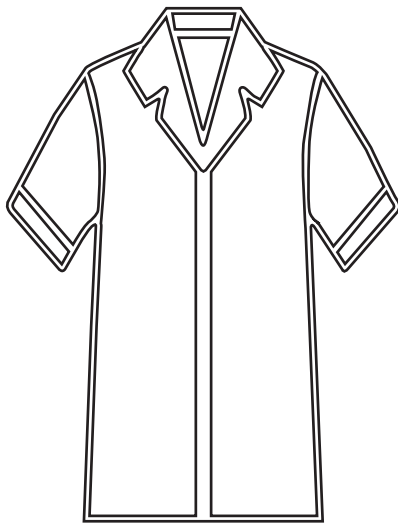

Figure 10.8 Shirt

10.4.5 T-shirt

This is simple and loose fitted top with a collar or round neck and a simple sleeve. It can be worn by both girl and boys.

Suitable fabric: woven cotton, all kinds of knitted fabric.

Suitable colour: white, pink, blue, yellow, orange, green, purple, black, red.

Suitable design: plain and printed, small motifs.



Figure 10.9 T-shirt



Who invented T-shirt?

Though the Cooper Underwear Company popularized the crew-neck shirt, they did not invent the style. The shirts evolved out of the long Johns that men wore in the 19th century, when a number of garment makers experimented with methods that would allow the fabric to stretch over the head and then snap back into shape. Gradually, the crew-neck caught on. In 1920, the garment was reborn under another name, thanks partly to F. Scott Fitzgerald. According to the Oxford English Dictionary, the author was the first to use the word “T-shirt” in print.



10.5 Material Suitable for Adolescent Girl Garment

In this period there is transfer of childhood to adulthood. There is a rapid growth both physically and mentally. Their dressing sense also changes from parental guidelines to peer group fashion garments. The commonly used garments among adolescent girls are,

10.5.1 Salwar and Kameez

Salwar is a loosely fitted pant which is worn by girls as a casual wear and also as a formal wear. It is constructed with breathable fabric. It gives great comfort. Kameez is a simple knee length top with a loose fit. Variations can be given at neck, and sleeves. It also provides comfort for the wearer.

Suitable fabric : cotton, silk, satin, synthetic, jute cotton blend, blended fabrics.

Suitable colour : red, white, pink, blue, yellow, orange, green, purple.

Suitable design : dyed designs, woven designs, plain, printed, hand painting, surface enrichments.

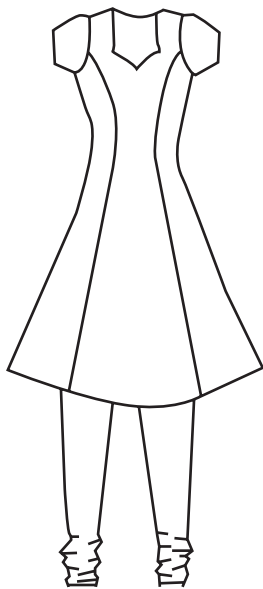

Figure 10.10 Salwar and Kameez



How was salwar invented?

The history of salwar kameez as a garment is quite rich. This garment dates back to the pre-Mughal Era and was worn by everyone in the Indian subcontinent. The traditional salwar kameez set was invented in the Punjab region and is still extremely relevant when it comes to the Indian ethnic fashion world. It was an amalgamation of the tunic and loose pants worn by the Mughals and the draped outfits worn by the indigenous common folk. Today, it is worn by women almost on a daily basis and is considered to be one of the most comfortable garments to wear. This is something that helps setting it apart from other garments in the market.



10.5.2 Skirt and Kurta

Skirt is a flared and beautiful garment which is commonly worn among girls as a fashionable and casual wear. Kurta is a simple top with long or short sleeve, either with opening at front or back.

Suitable fabric : synthetic, cotton, silk, denim, jute cotton, blended fabrics.



Suitable colour : white, pink, blue, yellow, orange, green, purple, light green.

Suitable design : plain, printed with small or big motifs, dyed, painted, surface enrichments such as embroidery etc.

10.5.3 Middy and Middy Top

Middy is a simple knee length skirt mostly worn in summer season and as a casual wear. Middy top a shirt or a t-shirt which is more comfortable can be worn loosely or fitted.

Suitable fabric: cotton, silk, synthetic, velvet, denim, blended fabrics.

Suitable colour: white, pink, blue, yellow, orange, green, brown, red.

Suitable design: plain, printed, dyed designs, surface enrichments-embroidery and laces.

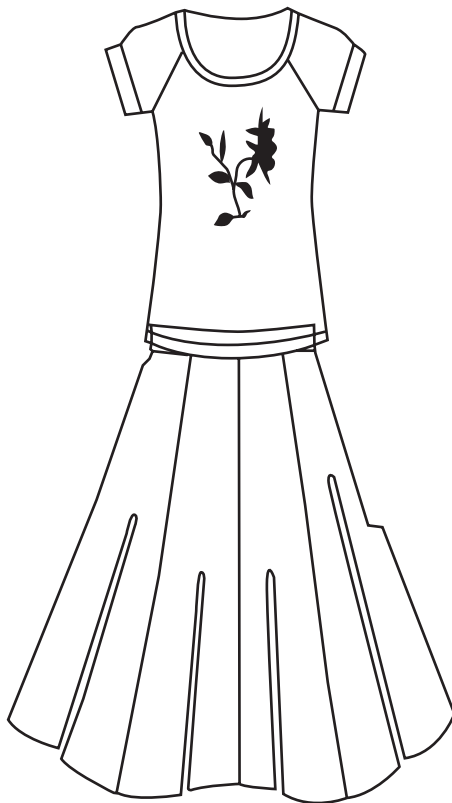

Figure 10.11 Middy and Middy top

10.5.4 Pant and Top

Pant is a basic garment worn from waist to ankle length. Top is an upper garment either with long or short sleeve, with collared or simple neck, with opening in front or back.

Suitable fabric: denim, cotton, blended fabrics

Suitable colour: pant: black, grey, blue, brown, red, creme, white.

Top: white, pink, green, yellow, blue, orange, brown, red.

Suitable design: plain, textured, printed, woven designs.

10.6 Material Suitable For Adolescent Boy's Garments

Like girls, they also have rapid growth and changes in both physique and mentally. The shoulders broaden and height increases. Their clothing selection is directed towards their peer group costumes. Commonly used garments among adolescent boys are,

10.6.1 Shirt

This is worn by all stages of boys and men. Shirts are constructed with yoke, collar, cuff, sleeve and bodice. It is mostly a loose fitted garment.

Suitable fabric: linen, cotton, denim, blended fabric.

Suitable colour: blue, black, brown, grey, sandal.

Suitable design: small motifs, plain, checked, stripes, abstracts.





10.6.2 T-shirt

T-shirt is a simple upper garment with round neck. It can either have a long or a short sleeve.

Suitable fabric: cotton, knitted and blended knits.

Suitable colour: yellow, white, pink, blue, orange, green, purple, crème.

Suitable design: design, geometrical design, small motifs, plain.

10.6.3 Pant

Pant is a basic garment worn from waist to ankle with two legs joined at crotch.

Suitable fabric: cotton, denim, blended fabrics.

Suitable colour: blue, black, brown, grey, sandal, crème, green.

Suitable design: woven textured.

10.7 Material Suitable for Women's Garment

Womens are highly fashionable. Based on the fashion trend the textile manufacturers produce the garments and governed by their activities and physical structure.

10.7.1 Sari Petticoat

It is a fundamental garment which is worn before wearing the saree. It is a basic skirt.

Suitable fabric: cotton, satin (woven).

Suitable colour: blue, black, brown, grey, sandal, red, yellow, that matches to colour of the saree.

Suitable design: plain.

10.7.2 Maxi, House Coat

Maxi is a long garment with loose fit, worn as a casual wear. House coat is a comfortable garment which is worn at home.

Suitable fabric: cotton, blended fabric, satin fabric.

Suitable colour: pink, red, blue, green, orange, yellow.

Suitable design: small motifs, plain, checked, stripes, abstracts, geometric, conventional motifs.

10.7.3 Saree Blouse

Saree blouse is a waist length and tight fitted garment with darts on it. It is worn before draping the saree.

Suitable fabric: cotton, silk, synthetic, blended fabric, velvet, netted, laced.

Suitable colour: blue, black, brown, grey, sandal.

Suitable design: plain, checked, stripes, small motifs, printed, surface enrichments.

10.7.4 Night Wear

Night wear is mostly worn as a casual garment at home or during sleep. It is a loose garment which is made of more soft, more breathable fabric. It is more comfortable during sleep.

Suitable fabric: cotton, satin, blended fabrics.

Suitable colour: blue, light pink, yellow, green, pink, orange.

Suitable design: woven, knitted with small designs

10.8 Materials Suitable for Mens Garment

Mens garments mainly depend on the type of occasion, like formal, casual, party wear. The selection of material also depends on these occasions. Their garments are also based on the season. The age of men ranges



from 21 years. It is divided into early adult hood, middle age, late adult hood.

10.8.1 Shirt

Shirt is the basic garment with yoke on the back; either with full sleeve or half sleeve, the collars is varied according to the occasion and age group. The designs or prints in the shirt are based on the type of occasion.

Suitable fabric: cotton, linen, rayon, denim, blended fabrics.

Suitable colour: blue, green, brown, black, grey, half white.

Suitable design: striped, checks & plaid, abstract, geometric designs.

10.8.2 T-shirt

T-shirt is a simple garment either with round collar or straight collar. It can have short or long sleeve, some t-shirts also have hoods.

Suitable fabric: cotton, knitted, blended knitted fabrics.

Suitable colour: blue, yellow, green, red, half white, black, brown, grey.

Suitable design: small prints, geometrical designs.

10.8.3 Shorts, Bermudas

These are mid length or knee length lower garment. It is worn as a casual wear and night wear by both men and boys.

Suitable fabric: cotton, denim, blended fabrics, woven and knitted fabrics.

Suitable colour: blue, green, black, brown, half white, grey.

Suitable design: checks, plaid, stripes and plain.

10.8.4 Pant

It is a full length lower garment. They are worn by men as a formal wear. Casual wear pants are also available. They are one of the most comfortable garments.

Suitable fabric: denim, cotton, blended fabrics.

Suitable design: woven designs.

10.9 Requirement of Material for Selected Garments



Table 10.1 Requirement of Material for Selected Garments

S.No	Name of the Garment	Materials Required		
		One Way Design	Stripes	Plaids
1.	Jabla	Half meter of suitable fabric.	Half meter of suitable fabric.	Half meter of suitable fabric.
2.	Panty (3 yrs old)	Panty length+ 15 cm	Panty length+ 15 cm	Panty length+ 15 cm
3.	Knicker (3 yrs old)	Knicker length+15 cm	Knicker length+15cm + 5 cm	Knicker length+15cm + 10 cm
4.	Romper	1 meter	1 meter	1 meter+0.25cm

5. Frock variations				
a)	Plain frock (without sleeve and collar)	Frock length+12.5 cm	Frock length+12.5 cm	Frock length+12.5 cm
b)	A-line frock (with sleeve and collar)	Frock length + sleeve length +15 cm	Frock length + sleeve length +15cm +0.25cm	Frock length + sleeve length +15 cm +0.50cm
6. Skirts (4-8yrs)				
a)	Plain short skirt with minimum flare	2 × skirt length+15 cm	2 × skirt length+15 cm	2 × skirt length+15 cm
b)	Gathered skirt	2 × skirt length+15 cm +10 cm for band	2 × skirt length+15 cm +10 cm for band	2 × skirt length+15 cm +10 cm for band
c)	Pleated skirt	skirt length+15 cm +10 cm for band	skirt length+15 cm +10 cm for band	skirt length+15 cm +10 cm for band
d)	Full skirt	skirt length+15 cm	skirt length+15 cm	skirt length+15 cm
7. Blouse				
a)	34-36"	Back waist length+ sleeve length +25 cm	Back waist length+ sleeve length +25 cm + 0.20cm	Back waist length+ sleeve length +25 cm + 0.20cm
b)	30-32"	Back waist length+ sleeve length+ 12.5 cm	Back waist length+ sleeve length+ 12.5 cm +0.20cm	Back waist length + sleeve length + 12.5 cm +0.25cm
c)	38-40"	2x back waist length+ sleeve length+7.5 cm	2x back waist length+ sleeve length+7.5 cm +0.30cm	2x back waist length+ sleeve length+7.5 cm +0.50cm
8.	Salwar	2x garment length+25 cm	2x garment length+25 cm+0.25cm	2x garment length+25 cm+ 0.25cm
9.	Kameez	2x garment length + 10(2meter)+ 0.5cm	2x garment length + 10(2 meter)+0.5cm	2x garment length + 10(2meter)+ 0.5cm
10.	House coat	2x garment length + sleeve length+30 cm+0.5cm	2x garment length + sleeve length+30 cm +0.5cm	2x garment length + sleeve length+30 cm +0.5cm
11.	Pant	2x pant length+ waist belt width(10 cm)+15 cm	2x pant length + waist belt width(10 cm)+15 cm	2x pant length + waist belt width(10 cm)+15 cm
12. Shirt				
a)	Slack shirt(6yrs)	Shirt length+15 cm+ sleeve length+0.25cm	Shirt length+15 cm+ sleeve length+0.25cm	Shirt length+15 cm+ sleeve length+0.25cm
b)	Full shirt with yoke (6yrs)	2x length of shirt+ 20 cm+0.25cm	2x length of shirt+ 20 cm+0.25cm	2x length of shirt+ 20 cm+0.25cm
c)	T-shirt(6yrs)	2x full length+ sleeve length+ 10 cm+0.25cm	2x full length+ sleeve length+ 10 cm+0.25cm	2x full length+ sleeve length+ 10 cm+0.25cm
13	Kurta (6yrs)	2x kurta length +5 cm+0.30m	2x kurta length +5 cm+0.30m	2x kurta length +5 cm+0.30m

14.	Pyjama(10 yrs)	2x garment length+15 cm	2x garment length+15 cm	2x garment length+15 cm
15.	Saree petticoat(6 gore or 4 gore)	2 x petticoat length (2.10m)	2 x petticoat length (2.10m)	2x petticoat length (2.10m)
16.	Sun suit (3 yrs)			
a)	Sleeveless shirt with straight collar	Shirt length +15cm+ 0.10cm	Shirt length +15cm+ 0.10cm	Shirt length +15cm+ 0.20cm
b)	Shirt with Sleeve & peter pan collar	Shirt length+ sleeve length+20 cm+ 0.15cm	Shirt length+ sleeve length+20 cm + 0.15cm	Shirt length+ sleeve length+20 cm + 0.30cm
c)	Shirt with yoke, sleeve, collar and pleated or gathered lowered section	2x shirt length+10 cm+0.20cm	2x shirt length+10 cm+0.25cm	2xshirt length+10 cm+0.25cm
17.	Knicker	Knicker length+15 cm	Knicker length+15 cm	Knicker length+15 cm

10.10 Basic Construction Method

Garment construction is a wonderful art, which requires skill and practice. One has to undergo through the instructions before sewing the garment to obtain beautiful finish, comfort, and a well fitted garment.

10.10.1 General steps for Construction of Garments

General steps involved in garment construction are,

- Check if all patterns are cut
- Fold the patterns and keep it safely
- Open the patterns only while sewing
- Mark and match the notches before sewing
- Collect all the necessary accessories before starting sewing. Like, lining, fasteners, decorative laces and appliqués
- Check the colour of the machine thread

- Fill the bobbin with suitable colour threads
- Check the smoothness of the machine
- Clean the machine thoroughly especially the bobbin holder and feed dog

10.10.2 Steps for Construction of Basic Blouse

- Mark pattern on to the fabric and cut the fabric
- Mark all the details such as darts and notches etc
- First finish the darts
- Join shoulder to neck line
- Join the side seams
- Finish the placket at the openings
- Finish the neckline
- Attach the sleeve to the bodice
- Finish the hem lines
- Attach fasteners
- Press neatly

10.10.3 Steps for Construction of Basic Skirt

- Complete the darts
- Finish the plackets
- Join the side seams
- Attach the waist band
- Fix the fasteners
- Press neatly
- Finish the front opening placket

10.10.4 Steps for Construction of Shirt

- Mark the patterns on to the fabric
- Name the patterns correctly
- Cut front bodice, back bodice, yoke, collar band, main collar and pocket
- Stitch the yoke on the back of the shirt
- Finish the plackets on the front openings
- Attach collar and collar band
- Join shoulder to neck
- Attach collar at neckline
- Attach side seams and finish the bottom of the shirt
- Join the sleeves
- Press neatly

10.10.5 Steps for Construction of Pant

- Mark the pattern on the fabric
- Cut the fabric accordingly
- Join the crotches
- Stitch the fly opening
- Attach the zipper
- Join the side seams and centre seam
- Attach the waist band
- Fix fasteners
- Press neatly

10.11 Sewing Tips

- All the seams need double machining. This helps the stitch not to rip so easily.
- While sewing the shoulder seams, start from the armhole edge to the neck edge, double machine the seam. Make sure that the second stitch does not shift from the seam line.
- All the straight seams should be stitched in a straight line, irregularities will affect the appearance of the garment.
- While attaching the facing, keep the work piece straight.
- While making gathers, set machine on the largest stitch size, loosen the top tension slightly and machine two rows, one on the seam line and one 0.56 centimetre above it. Wind the top threads round a pin and pull up to the desired length by the bobbin thread only. Ease the fabric gently while pulling to avoid breaking the thread.
- While attaching an eased or gathered section of a garment, always keep it on top to ensure evenness and to keep the gathers from shifting.
- While attaching pocket and while stitching down the pleats, double-machine the edges for reinforcement.
- While attaching ruffles or lace, provide extra ease at corners.
- A curved seam is stitched in the same way as plain seam but the edges are notched so that the seams may be pressed flat.

10.12 SUMMARY

This chapter helps in the selection of the fabric for different garments, method of calculating the requirement of fabric to construct the garment. It also helps to

know the basic steps in constructing a garment. If one goes through the aspect of the lesson, they can confidently make the garment which looks more attractive and pleasing.

POINTS TO REMEMBER

- Cotton is a lightweight, semi-sheer fabric, slightly crisper.
- Silk can be packed in small spaces; in dark colours they do not show dirt; wrinkles and crepe will hangout especially well.
- A nylon-rayon blend makes a fine-count, strong yarn for light weight washable fabrics.
- Rayon is a semi synthetic material which is made from cotton linters or from the soft tissues of trees such as spruce.
- Denim is a heavy weight fabric with very little drape or stretch and are normally used for making jeans, work clothes as well as casings for pillows.
- Bib is wrapped around the neck, so that it protects the baby clothing from food spills, moisture and soil.
- Bonnet is the simple caps that are worn on the head to regulate the temperature and the head and ears are specially protected from the sudden change in temperature.
- Rompers should be designed in such a way that it can be slipped off easily and quickly.
- Pant or shorts is a basic garment worn from waist to knee or waist to ankle with two legs joined at crotch.
- Salwar is a loosely fitted pant which is worn by girls as a casual wear and also as a formal wear.
- Kameez is a simple knee length top with a loose fit and variations can be given at neck, and sleeves.

ACTIVITIES FOR TEACHER

- To show the procedure for selecting the right fabric for the right Garment.
- To show various samples of fabric for each garment

ACTIVITIES FOR STUDENTS

- A visit to a Garment production Factory
- An album of different patterns of each garment to be circulated among students.



INTERNET RESOURCES

http://www.youtube.com/watch?v=n_Rme2R13ik	Style tips: How to choose a dress that fits your body type
http://www.youtube.com/watch?v=9wkaB2UtuUI	Clothes to take on a cruise

Cotton	A lightweight, semi-sheer fabric, slightly crisper.
Silk	Can be packed in small spaces; in dark colours they do not show dirt; wrinkles and crepe will hangout especially well.
Rayon	A semi synthetic material which is made from cotton linters or from the soft tissues of trees such as spruce.
Denim	A heavy weight fabric with very little drape or stretch
Bib	Wrapped around the neck, so that it protects the baby clothing from food spills, moisture and soil.
Bonnet	Simple caps that are worn on the head to regulate the temperature
Salwar	A loosely fitted pant which is worn by girls as a casual wear and also as a formal wear.
Kameez	A simple knee length top with a loose fit

QUESTIONS AND ANSWERS

PART – I

Objective Questions

- Fill in the _____ with suitable thread.
 - Bobbin
 - Spool
 - Needle
 - Bobbin case
- Double machining will ensure that the seams do not _____.
 - Pucker
 - Rip off
 - Tear
 - Worn out



- Shirt collars are usually finished with _____.
 - Facing
 - Bias
 - Interfacing
 - Placket
- Construction of a _____ is a suitable art.
 - Garment
 - Sun suit
 - Romper
 - Shirt

PART – II

Answer in Three (Or) Four Points

1. Basic steps involved in garment construction.
2. What are the Steps involved in construction of blouse?
3. Describe about selection of fabric for kids garment?
4. Write in short about the types of fabric?
5. What are two parts of collars?

PART – III

Answer in a Paragraph

1. Describe in detail about the fabric selection for infants.
2. Write in detail about the steps involved in garment construction.

PART – IV

Answer in One Page

1. Explain in brief about the tips involved in sewing.
2. Explain in detail about procedure followed in the construction of
 - a) Blouse
 - b) Skirt
 - c) Shirt
 - d) Pant

Answers for Objective Questions

1. a)
2. b)
3. c)
4. d)

Home Made, Tailor Made and Readymade Garments

CHAPTER

11



LEARNING OBJECTIVES

- To gain knowledge on the methods of garment manufacturing
- To learn the differences among home-made, tailor made and readymade garments

11.1 Introduction

Clothing has always been important to people because it meets one of their primary needs of human being. Thus, clothing and textiles tend to reflect and offer an important basis for interpreting the social, economic, and political conditions of a nation. Clothing industry or the fashion industry is also a part of garment or apparel industry. The origin of apparel industry dates back to Stone Age when man used leaves, barks and animal skin for covering oneself for protection from climatic conditions.

The apparel industry in the United States has gone through several stages, as follows:

- **The Family Stage**

During which all clothing was made at home by family members.

- **The Hired Stage**

In this stage, families engaged a dressmaker or tailor to come into their homes and make their clothing.

- **The Customer Stage**

In this stage dressmakers or tailors maintained shops to which patrons came to have their clothing made.

- **The Commercial Stage**

This introduced men's and women's furnishing stores that featured ready to wear as well as custom apparel; and

- **The Manufacturing Stage**

This supplied readymade clothing for retail and wholesale trade. There has been considerable overlapping of these methods of clothing production, so that all five stages may be found in most periods of our history.

As the nation became more prosperous and secure, people showed more interest in fashion. Around 1800 century, the custom tailor shops appeared. Here the independent tailor made garments for his customers were made on special order. The seamstress appeared somewhat later. Seamstresses set up shops

side by side with the tailors and became known as mistress dress makers.

In general, the apparel industry concentrates on three major methods of garment making namely home-made, tailor made and ready-made.

11.2 Home Made Garments

Home-made garment, as the name indicates are the clothes stitched by the family members for the family members or friends.

11.2.1 History of Home-made Garments

Home sewing remained an individual endeavour until 1863, when Ebenezer Butterick, a tailor and shirt maker by trade, in collaboration with his wife, Ellen, put on the market a set of shirt patterns. All garments were sewn by hand until the development of the sewing machine, which was first introduced in the early 1850.

11.2.2 Description of Home-made Garments

Home-made garments are constructed efficiently at home as and when required for the family members and also express their talents and interest of the member who sews the garment. If the members in the family are interested and talented in garment construction, they can very well produce garments in the home.

Those who make their own clothing at home have several reasons for doing so. The reasons will vary from family to family, based on the degree of importance given to a particular reason. Home sewing may be done to stretch the family budget although studies indicate that this factor is not as important as it once was.



Figure 11.1 Homemade Garments

11.2.3 Merits of Home-made Garments

- More economical in garment making especially for middle income and low income families
- Requires and increases special talent and involvement among families
- Need not depend on any one outside agent for their garments
- It helps to create unique style among others
- Even though it is time consuming, satisfaction could be achieved in fit and comfort
- Quality garments could be produced based on the availability of the sewing machines and finishing machines
- Motivate creativity among family members.
- Express individual's knowledge and skill in construction.
- Enrichment of the knowledge experience is possible by multiple and regular constructions.
- Applications of CAD in home sewing simplify the procedure.

- Use of old materials is possible.
- Use of bits and unused materials, got while sewing other garments can be combined to make new garments.

11.2.4 Demerits of Home-made Garments

- Time consuming when compared to tailor made and ready made
- It needs special skill and talent to get good style and fit
- Perfections may not be impossible when compared to readymade.
- It needs adequate knowledge about material types and design styles. Only then it could be managed.

11.3 Tailor Made or Custom Made Garments

Garments made by a person who has knowledge about construction and sews for payment is rightly called as tailor made. Generally the garment is made according to taste and preferences of the individual who is going to wear it. The tailor-made is the opposite of ready-to-wear; it is the realization of a garment according to the morphology and desires of the customer.

11.3.1 History of Tailor-made Garments

English tailoring history dates from the Norman Conquest, at which a more elaborate style of dress was introduced than that to which the simple-living Saxon had been accustomed. In the year 1100, Henry I confirmed the royal rights and privileges to the merchants of Oxford, and by the year 1300 English tailoring had developed to a high degree of craftsmanship. It was in the fourteenth century that the button

was devised and this made possible a closer fitting garment. In the same period, dress began to increase in sumptuousness and extravagance, reaching its height in the sixteenth century, and then declining until the industrialism of the nineteenth century. Prior to 1850 all garments were made entirely by hand, but with the introduction of the sewing machine the development of machine-made garments became possible.

11.3.2 Description of Tailor-made Garments

The garments which are constructed with the help of a tailor based on requirement are known as tailor made garments. A tailor is a person who makes garments, repairs or alters clothing up to the satisfaction of the customers. A skilled tailor can make simple clothing from available common fabric material but with time and practice they can learn to create garments of great quality and beauty. A tailor progresses and becomes more skilled as they are able to design beautiful clothing and accessories to compliment every kind of adventure sewing professional work inside the home or out of their home and may work part time or full time. The garments could be constructed at home or with the help of tailors efficiently.



Figure 11.2 Tailor-made Garments

11.3.3 Merits of Tailor-made Garments

- Economical way of garment making
- Proper fit can be obtained

- This method helps customer to select unique style
- Time saving when compared to home-made garments
- Since skilled tailors work on garment making, the finished garment gives neat appearances.

11.3.4 Demerits of Tailor-made Garments

- Delay in deliver of garments especially during festival seasons.
- Need to depend on tailors for alterations.
- Time consuming when compared to readymade.
- Minimum styles are available for designing.
- Expensive as they are designed and constructed for single person.

11.4 Ready Made Garments

The garments which are available readily in the shops for different age groups with varied colour combinations, up to date styles, latest prints, and trims and also suitable for different occasions and seasons are known as readymade garments. Ready-to-wear is the transition from handmade sewing and tailor-made garments to standardization of sizes for mass production.

11.4.1 History of Ready-made Garments

Readymade clothing had its beginning in the United States between 1825 and 1830. The first manufacturing establishment in New York City was founded by George Opdyke, a former mayor. He opened a

factory on Hudson Street in 1831. By 1835, there were several manufacturers of medium grade ready to wear clothes for men in New York; however, the quantities produced were small, and everything was done by hand. The south became an early market for readymade clothes before 1840.

The improvement in ready-made clothing, the wider choice of styles and fabrics, and the ease with which such clothing can be secured have encouraged mainly the homemakers to purchase family wardrobes of ready to wear apparel.

11.4.2 Description of Ready-Made Garments

In the present changing life style, each and every member in the family likes to follow latest trend with regard to their wardrobe. They want to dress up neatly and like to display their status. In today's fast moving life, it is difficult to take the time for getting clothes stitched. We have to go to the market to buy a fabric, look for a toiler order stitching and wait till the dress is ready. To overcome this problem we have an alternative method of buying a readymade dress. Almost for all occasions family members prefer to buy their garments from the leading readymade shops. They are abundantly available for all the age groups. Suitable accessories are also available along with the garments.



Figure 11.3 Ready-made Garments

11.4.3 Merits of Ready-made Garments

- They are readily available in many places
- Numerous variety in style and materials are possible
- Garments for various seasons and occasions could be purchased whenever necessary
- Saves times spent on construction as in case of tailor made and homemade garments
- Latest trends in fashion could be updated
- Branded goods could be purchased on availability
- Easy care of fabrics is possible with suitable label instructions
- Customers can try out the garments for their personal fitting

11.4.4 Demerits of Ready-made Garments

- Knowledge about proper size is required before getting readymade garments
- Garments may not match the taste of the buyer
- Proper fitting is not possible sometimes due to wrong size
- Expensive than tailor and home-made garments
- In some cases, the readymade garments are less durable due to poor quality in stitching

11.5 Boutiques

The word boutique has become more popular these days but it started as concept stores. These places provide recent



fashion garments, best suited for all occasions. Today many of the celebrities go to boutiques to select their dresses.

11.5.1 What are Boutiques?

Boutique is a small shop selling fashionable clothes or accessories. It is also known as a business serving a sophisticated or specialized clientele. The term “boutique” and also “designer” refer (with some differences) to both goods and services which are containing some element that is claimed to justify an extremely high price, is known as boutique pricing. Boutique has various types of fabrics which one can select, match to his/her look and design in a garment. It also has semi stitched or full stitched ready to wear a fashionable garments. An individual could select them and alter it, if needed to provide good fit.



Figure 11.4 Boutique

11.5.2 History of Boutiques

In the late 1990s, some European retail traders developed the idea of tailoring a shop towards a lifestyle theme, in what they called “concept stores” which specialized in cross-selling without using separate departments. One of the first concept stores was 10 Corso Como in Milan, Italy, founded in 1990, followed by Colette in Paris and Quartier 206 in Berlin. Several well-known American chains such as Tiffany and Co., Urban Outfitters, Dash, and The Gap, Australian chain Billabong and, though less common, Lord and Taylor, adapted to the concept store trend after 2000.

11.5.3 Merits of Boutiques

- Specialization in apparel selection and design.
- Own price advantage and expand clothing display scope.
- Improve clothing enterprises by quick response ability.
- Provide more promotion activities thereby meeting consumers personalized demands.

11.5.4 Demerits of Boutiques

- Lack of large variety in design
- Logistics and distribution problems
- Quality and label problems
- Cannot cater to needs of lower income

11.6 Designer Garments/ Wear

Designer garments are similar to boutique garments, but here a particular person with very good knowledge about fashion



When boutique was first started?

As a retailing concept, the boutique is associated with a distinct identity that reflects the taste of the designer or owner; small-scale production with rapid turnover of merchandise; fashion novelty and experimentation; innovative displays and interiors; and an informality among owner, salespeople, and clientele. Although the boutique phenomenon of the 1960s played itself out by the mid-1970s, boutiques remain a vital part of the commercial world of fashion- whether as an individual enterprise or incorporated into a larger setting, such as a department store.



and skill in garment construction, foresees the upcoming fashion, sketches garment designs, sometimes develop fabrics suitable for a particular type of garment. A boutique might not have a designer, but usually a designer might have small set up to rather a unit, where he/she can develop patterns cut and stitch. A designer can foresees the upcoming fashion and design a range of garments for either one sex or both sexes of different age groups. Some designers work only for one person. Example- Famous celebrities, movie and the costume designers:

Table 11.1 Designer Garments Wear

Costume Designer	Celebrities Name	Movie
Neeta Lulla	Aishwarya Rai	Jodha Akbar
Anju Modi	Deepika Padukone and Ranveer Singh	Bajirao mastani
Nalini Sriramn	Surya and Tamana	Ayan
Vasuki Baskar	Leading roles in the movie	Kangalal kaithu sei, Chennai 600028, Saroja, Abhiyum Nanum, Goa, Mankatha, Aarambham
Neeraja Kona	Samantha Ruth Prabhu	Mersal
Anu Vardhan	Rajnikanth and Shahruhk Khan	Ashoka (period flim) and Kabali

11.6.1 Merits of Designer Garments

- Unique and made to suit the person
- Very good quality and craftsman ship
- Duplication becomes difficult

11.6.1 Demerits of Designer Garments

- Cost is very high
- In rare case, a designer's garments may not be successful

11.7 Apps for Ready-Made Garments

In present world, the mobile applications have been creating one buzz after the other. According to the stats of business of fashion,

the fashion industry has witnessed a growth of about 2.5-3.5% in the year 2017, which was about 3.1% in 2016. Healthy growth of online shopping in previous years and projections indicating boom time has led several companies to launch e-commerce websites for fashion industry. Traditional shops retained their hold while newer ones consolidated their market position in online. Some of the top online apps for readymade garment shopping are



Figure 11.5 Top Online Shopping Apps for Ready-made Garments

11.8 Online Shopping of Ready-Made Garments

Online shopping is the trend of the day where in one can sit at his own place and order on his phone, computer or anyone system. One views the products which are put up on internet, choose and place order. In India, studies by Internet and Mobile Association of India and Indian Market Research Bureau indicate shows about 500 million internet users used online by June 2017. Urban India with an estimated population of 444 million already has 269 million (60 percent) peoples using the Internet.

Over 100 million Indians will have made at least one online purchase in 2017 as compared with 69 million in 2016, a

joint report by Associated Chambers of Commerce and Industry of India and Resurgent India states.

11.8.1 Merits of Online Shopping

- It provides the product with better prices.
- We can get more varieties of product.
- It can give us an opportunity to shop 24/7.
- There is no crowd while online shopping we are free to purchase it any time.
- One can also buy older and unused products at the lesser price.
- One can get their expenses on shopping reduced, like there is no expense on buying and eating out and also in transportation cost.
- Can send gifts more easily to our relatives and friends.

11.8.2 Demerits of Online Shopping

- Delay in delivery
- Lack of significant discounts in online shops
- Lack of touch and feel of merchandise in online shopping
- Lack of shopping experience
- Frauds in online shopping
- Lack of interactivity in online shopping

11.9 SUMMARY

Generally garment manufacturing is carried out in three different methods, namely homemade, tailor made and readymade. As the name indicates homemade is garments made at home by the family members for their family, friends and relatives. Tailor made is garments constructed by a person specially trained using individual body measurements as per the likes on the person. Readymade garments are mass construction of garments for a standardized body measurement. In this case a garment is designed and stitched for various sizes and marketed. Boutiques are becoming a common today. These are small fashion shops where a highly skilled person sews garments for an individual based upon his physical appearance for a specific occasion. Apart in the age of digitization there are many apps, internet and e blogs through which one can buy clothes. Garment making which was once a small job of interest in the family has become a worldwide occupation. Apart the idea of clothes as a means of protection and modesty has changed as fashion clothing for every event mainly through the different methods of garment construction.

POINTS TO REMEMBER

- Home-made garments are more economical method of garment making especially for medium families
- A tailor is a person who makes garments, repairs or alters clothing up to the satisfaction of the customers
- Boutique means a small shop selling fashionable clothes or accessories

ACTIVITIES FOR TEACHER

- Arrange a field visit to readymade garment industry.
- Collect different types of home, tailor and readymade garments and show it to the students.

ACTIVITIES FOR STUDENTS

- Ask students to collect different patterns for tailor made garment design
- To encourage students to gather information on how to start a boutique



INTERNET RESOURCES

https://www.youtube.com/watch?v=nLiGsQgCrLw	Owning a fashion boutique - Young entrepreneur
https://www.youtube.com/watch?v=RKjlmj5exiM	How to shop for clothes online and measure garments

A-Z GLOSSARY

Home-made garment	The clothes stitched by the family members for the family members or friends.
Tailor made Garments	Garments made by a person who has knowledge about construction for payment
Boutiques	These places provide recent fashion garments, best suited for all occasions
Designer Garments	A particular person with very good knowledge about fashion and skill in garment construction, foresees the upcoming fashion, sketches garment designs, sometimes develop fabrics suitable for a particular type of garment.
Online shopping	The trend of the day where in one can sit at his own place and order on his phone, computer or anyone system

QUESTIONS AND ANSWERS

PART – I

Objective Questions

- _____ has always been important to people because it meets one of their primary needs.
 - Fabric
 - Clothing
 - Sample
 - Yarn
- _____ increases special talent and involvement among families.
 - Homemade garment
 - Readymade garment
 - Boutique
 - Tailor Made



3. Numerous varieties in style and materials are possible through _____.
 - a) Homemade garment
 - b) Readymade garment
 - c) Boutique
 - d) Tailor Made
4. Quality and label problems occurs _____.
 - a) Homemade garment
 - b) Readymade garment
 - c) Boutique
 - d) Tailor Made

PART – II

Answer in Three (Or) Four Points

1. What is homemade garment?
2. Who is a tailor?
3. Explain the term boutique.
4. What are the merits of readymade garment?
5. Give few online apps for shopping.

PART – III

Answer in a Paragraph

1. Write short notes on history of homemade garments
2. List the merits and demerits of tailor made garments

PART – IV

Answer in One Page

1. Compare readymade garments and boutique garments
2. Explain in detail about online shopping and its apps

Answers for Objective Questions

1. (b) 2. (a) 3. (b) 4. (c)

Apparel Merchandising

CHAPTER

12



LEARNING OBJECTIVES

- To know the meaning of apparel merchandising
- To understand the merchandising process
- To learn the methods used in apparel merchandising

12.1 INTRODUCTION

Merchandising is an important part of marketing. It is the planning and supervision involved in marketing a particular product and making it available at places, times, prices and in quantities that will best serve to realize the marketing objectives of a business. It involves all activities necessary to determine and satisfy the wants and needs of a consumer. It offers the goods at time and in a place where it can be conveniently purchased. The products must be available in good quantities and in qualities. In textile industry many methods of production are employed to produce products. The techniques adopted to sell the products to consumers are referred as apparel merchandising.

Merchandising deals with the selection, orders and purchase of actual product. One must understand that demand is the foundation upon which all retailers plan their merchandise. Merchandise is chosen carefully to best serve the needs of the target market. The merchandiser requires special skills which include, predicting what one will sell and when it will sell best. A thorough knowledge of the merchandise that includes garment types, its details and methods of production, qualities and finishes are prerequisites to merchandising.

Apparel merchandising involves a constant watch of the production of the apparel products. Merchandiser should be well aware of what a customer wants this season and whether the product produced by the manufacturer is as per the needs of the customer. He should inform the customer about the styles, quantity and quality of the product required and the time when the goods will reach the customer. Merchandising is the job where the merchandiser should have a constant interface with production and see that the ultimate aim of satisfying customer needs.

12.1.1 Definition of Important Terms

Merchandising may be defined as “All the planning and activities involved in bringing the goods or merchandise for sales to the customers so that it fulfils the customer needs ultimately brings customer satisfaction.” The process of apparel merchandising may be defined as the development, execution and delivery of a product line based upon the needs of a target market. Merchandising is a process of creating merchandise (goods bought and sold) based on a particular demand, whereas marketing is a process of supplying this merchandise for the market.

Merchandising is the process through which products are planned, developed, and presented to the identified target markets.

Marketing identifies the customer and determines what products to offer to that customer and how to do so while meeting the financial return objectives of the company. Sales are the operations that implement marketing and merchandising activities by physically selling the line to the retail customers according to marketing plans. Merchandising functions as a bridge between the design and sales to fulfill the needs of the buyer. Marketing is the management process through which goods and services move from concept to the customer. As a practice, it consists in coordination of four elements called 4P's. This includes identification, selection, and development of a **product**, determination of its **price**, selection of a distribution channel to reach the customer's **place** and the development and implementation of a **promotional** strategy.

According to American Marketing Association, merchandising encompasses “planning involved in marketing the right merchandise or service at the right place, at the right time, in the right quantities, and at the right price”. Merchandising accomplishes six Rights to replenish the customer. They are

- **Right Merchandise**

Retailers should have the merchandise that customer wants.

- **Right Place**

Appropriate location of the merchandise is important since it decides the accessibility.

- **Right Time**

Apparel purchases are mostly seasonal in nature and so must be supplied promptly when it is most needed.

- **Right Quantity**

Required amount of inventory to get profitable sales volume.

- **Right Price**

Suitable price for the store to get profit and also to meet the competition and customer expectations.

- **Right Promotion**

Right balance between the investment and the appeal created for the customer.

12.2 Merchandising in Apparel Industry

Merchandiser should have constant eye on the manufacture and communicate with the manufacturer to get the goods as per the requirement of the buyer. A slight deviation in the production of garments in quality may spoil the name of the retailer.

Delay in the production may also lead to a great loss for the manufacturer.

12.2.1 Importance of Merchandising in Apparel Industry

Apparel supply chain involves complicated raw materials and processes to get apparel products from concept to consumer. The apparel supply chain involves five major sectors.

- Fibres
- Yarn sector
- Fabric sector
- Garment sector and
- Retail sector

Quality standards and measurements have been set for all the above and other properties and characteristics of the raw materials by various Textile and Apparel Associations in their concerned countries. Apparel product is also associated with accessories and packing accessories. In order to monitor all these quality and other requirements the role of merchandising department plays a vital role.

Merchandising is essential due to the following factors:

- Dramatic growth
- Complicated raw materials and processes

- Complex network
- Advent of New styles
- Reduced product Life Cycle
- Textile innovations
- Computer applications
- Global transition

An apparel merchandiser should predict and implement merchandising displays in retail environments focused on the sales of clothing and accessories. They should also identify the best place to arrange a display within the store. Promotional items like banners, posters, and other apparatus are used to draw customers' attention. Merchandising not only mediates marketing and production departments, it sometimes does the costing and pricing also. It is the responsibility of merchandiser to execute the orders perfectly as per the costing and pricing. So it is a very valuable department.

12.3 Merchandiser

Merchandiser is basically a coordinator one who liase between buyer and apparel manufacturer to ensure quality merchandise at right delivery time. Merchandising involves all the activities right from communication to execution. Merchandiser is the person who takes in charge of all these activities. A good merchandiser has attributes of hard work,



Figure 12.1 Apparel Manufacture Supply Chain

sincerity, loyalty, team work, managing and negotiation in the apparel industry. Customer satisfaction and retention mainly depends on effective and efficient merchandising.

Function of Merchandisers

- Execution of sample orders
- Costing
- Programming
- Yarn procurement
- Production scheduling or route card drafting
- Accessories arrangement (order placing follow up).
- Approval of various processor's sewing operations
- Pattern approval or dummy size set approval
- Size set approval
- Pre productions follow up
- Pilot run inspection
- In process inspection
- Production controlling
- Identifying shortages & make arrangement to overcome the shortages
- Following quality control procedures
- Following quality assurance procedures
- Monitoring all the activities of in house & sub-contractors unit
- Buyer communication
- Communication with production unit processing units & other 3rd parties (vendors)
- Proper reporting
- Highlighting to the management
- Record maintenance
- Developing samples
- Placement of orders

- Taking measures for consistent production
- Taking preventive action to maintain the targeted performance
- Level in all areas of merchandising
- Attending meeting with superiors & furnishing the required details about merchandising

12.4 Process Flow in a Garment Industry

Garment manufacturing includes a number of processes from order receiving to dispatching and shipment of the finished garments.

12.4.1 Merchandising Department

Merchandiser is a person who interacts with the buyer and seller, and also puts efforts into proper relation between buying offices, buying agents, agency and seller, exporter in terms of executing an order. A garment export unit generally has many departments like stores, cutting, production, packing and checking. Merchandising department is the star of the department among all the working departments in the export concern, because merchandising is the only department having maximum control over the departments and totally responsible for profit and loss of the company. The job of a merchandiser is to coordinate with the entire department in the office as well as the customers. Merchandiser meets the buyers and collects the details of their requirements to develop the relationship with the customer. After conformation of an order from the buyer the planning process for execution of the order is done.

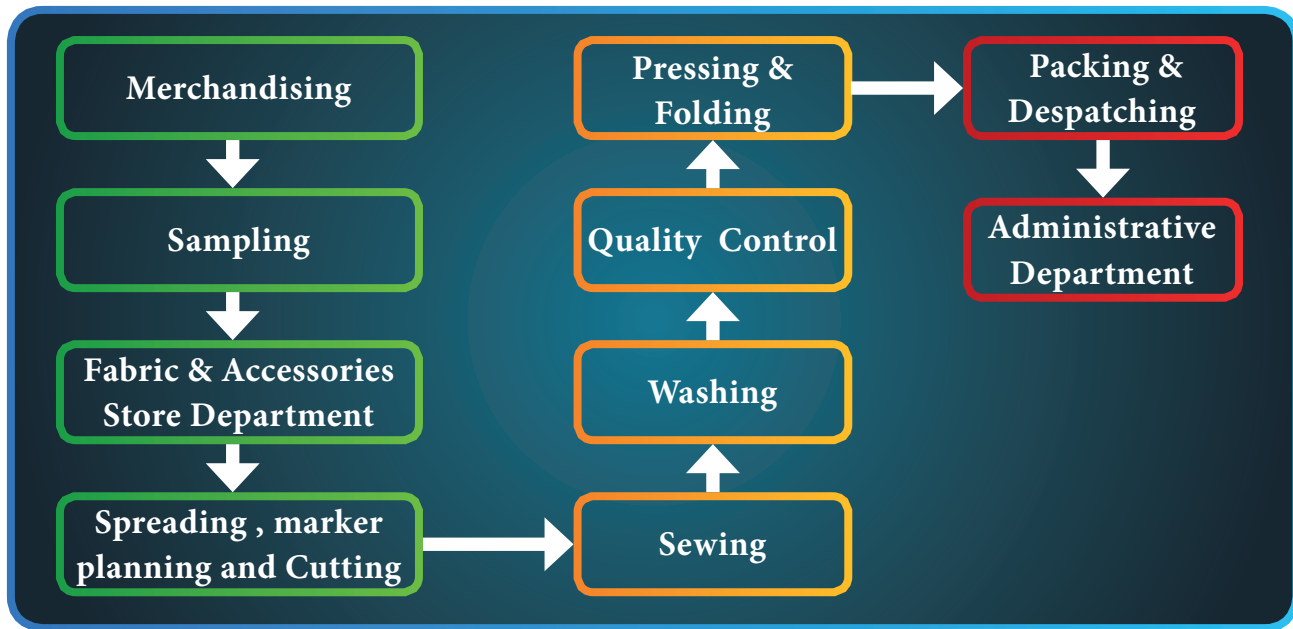

FIGURE 12.2 Departments in Garment Manufacturing Unit

12.4.2 Sampling

Designing and sampling are the main process in garment industry and it has a vital role in attracting buyers. The buyers generally place the order after they are satisfied with the quality of the samples. The samples decide the ability of an exporter. The buyer will access the exporter and his organisation only by the samples. The purpose of sampling is not only to get bulk orders and also give some additional benefits to the exporters. By doing sampling the exporter can estimate the yarn consumption for developing the fabric, a clear idea on costing and more over the manufacturing difficulties. There are different phases of sampling; the first phase covers the development of the initial concept or design idea through its approval by the customer. The second phase covers the process following acceptance of the first prototype sample and includes the functions of sourcing and ordering component, testing the product and carry out trials and finalized sample specifications. The third and final phase

phase includes a range of activities that are carried out before large scale or bulk production capacity outside the home producer or developers wherever this is applicable.

12.4.3 Fabric and Accessories Store Department

After receiving purchase order from the buyer merchandiser plans and issues purchase order for buying raw materials like fabric, buttons, thread, and for dyeing, printing, embroidery and other accessories. These raw materials' are checked for colour, quality and then approved by the merchandiser.



What are the most important fashion centres?

- USA - New York- Garment District (Madison Avenue)
- UK - London - British Fashion Council
- FRANCE - Paris-Chamber Syndic ale
- ITALY - Milan- Alta Moda
- GERMANY —Interstoff trade shows in May and November.

12.4.4 Spreading, Marker Planning and Cutting Department

Approved sample, pattern and measurement chart must be ready in the department. The head of the department will be a pattern master. His skill will be a very big asset to the company by way of saving the fabric and making new designs for the export trade.

Machinery required: one cutting machine. One table of 18 m/1.5m length and breadth

Spreading

In the cutting department, spreading plays a vital role. In spreading, the number of plies of fabric, that the production planning process has dictated to the length of the marker plan, colours required are correctly aligned as to length and width, and without tension. This saves time, cost of cutting and cost of materials.

Marker Planning

The amount of fabric consumed per garment and the total profit of the garment unit is decided by the marker planning and marker making. The length and width of the marker is very important here. Based on this marker only the spreading length will be decided. The fabric consumptions and fabric wastages depends on this marker making. The industry has always paid great attention to marker planning, because when the cutting room cuts cloth it spends around half the company's turnover. Any reduction in the amount of cloth used per garment leads to increased profit.

12.4.5 Sewing

Power operated machines preferably batch system is used to get uniform quality and

better productivity. Production in charge will be responsible for the sewing operation. He must know quality aspects in every stage, guide tailors and supervisors to get the work done at satisfactory level and to meet the targets. Additional to sewing machines, attachments, guides, folders are required for special operations. Machines like Double needle, Feed of arm, Button Hole and Buttoning machines are also required.

12.4.6 Washing Department

Either for effects or shrinkage garments are washed. Washes vary depending upon the type of fabric used and the type of garment. Some of the common washes are garment wash, stone wash, caustic wash, bleaching acid wash, sand wash and enzyme wash.

Machinery required : Washing machine, Hydro Extractor, Tumbler Drier, Store/ Chemicals

12.4.7 Quality Control

Quality is an important concept in all stages of garment production. To get the quality product, check and controls must be ensured in each stage of the production. This will also avoid all kinds of mistakes.

Prevention is better than cure and also do the things right at the first time. These will really bring an awareness in the production line. By any chance an alteration or a mistake in the garment is difficult to be rectified properly. For upkeep of quality, good housekeeping and cleanliness should be of top priority.

12.4.8 Pressing and Folding

Presentation of a packed garment makes all the difference in sales. The real skill

of the industry lies in this point. A well-tailored garment can be finished badly or a badly stitched garment can be presented properly. Garments can be folded as follows:

1. Stand up pack
2. Plat pack
3. Deadmen fold
4. Semi stand pack

Machinery Required

Steam pressing with vacuum table, Dummy blowers, Shift folding tables, Stain removing guns.

12.4.9 Packing and Despatching

In the garment export trade packing is an art and is a very important stage. If the presentation and packing is good, it will really attract customers and sales will be faster. Our ultimate aim must be to impress the buyer with quality product. While packing, ratios, size, colour, tables are to be observed and followed meticulously. As policy matters decision taking or making has to be done as early as possible. Delay in minutes/ hours will create problems and losses. Concentration, involvement and commitment will fetch real good foreign exchange to the entrepreneur and to the country in the international market.

12.4.10 Administrative Department

All the departments in a clothing industry require administrative support for their operations to ensure orderly and systematic functioning. The procedure covers preparing orders to supplies, checking goods, timing and methods of stock taking, imports and exports,

obtaining credits for returned goods and materials, issuing credit for customer returns, negotiating and issuing tenders for major projects and purchase of furniture and equipments.

12.5 Categories of Apparel Merchandising

1. Apparel fashion merchandising
2. Apparel production or export merchandising
3. Apparel retail merchandising



Figure 12.3 Categories of Apparel Merchandising

Activities like fashion forecasting, design, product development and retail sales come under fashion merchandising. It also includes production and retail merchandising.

Apparel production or export merchandising involves activities with the manufacturer or exporter, like sample development, planning and programming, manufacturing and shipment.

Apparel retail merchandising involves mainly retail business like retail promotion and sales, visual merchandising, inventory control, sales evaluation and retail operations.

12.6 Steps in Merchandising

- Fashion Forecasting - Studying the fashion forecast along with the designer
- Sourcing - of fabrics- mill made, power loom, handloom, woven, knitted etc and trims such as interlining, buttons, labels etc.
- Buyer Communication - Getting information about customer profile whether be a distributor, retailer or exporter, domestic or international
- Enquiry and Sampling
- Pre-Costing - Calculating the fabric consumption and estimating the cost
- Order confirmation and acceptance
- Order Review
- Planning and Programming
- Samples
- Accessories Sourcing and Purchasing
- Inspection
- Cutting and Production
- Packing
- Shipment



At every stage merchandiser has to co-ordinate with all the departments and follows up at every process. Buyer has to be intimated about the day-to-day progress of his order and merchandiser has to ensure quality at all stages of production.

12.6.1 Fashion Forecasting

Fashion Forecasting is the process of analyzing and predicting the future trends for the upcoming season in the industry. It is very important because without it

the manufacturers and retailers would not be able to produce and sell the goods. Raw material manufacturers have to be ready before one year for the selling season. Whereas apparel manufacturers and accessories manufacturers have to be ready by 9 – 12 months ahead of the selling season and retailers should prepare them at least 3 – 4 months ahead of selling season. So without forecasting these players cannot prepare and produce the right kind of style, design and type of materials.

Fashion forecasting can be done through various sources which could provide numerous information about the future fashion trends like colour, style, silhouette and designs. Some of the sources for forecasting are fashion magazines and bulletins, websites, TV channels, fashion predictive services, sales records and consumer surveys. Effective forecasting depends on how all the available information is processed analyzed and interpreted using the forecasting techniques.

12.6.2 Sourcing Materials and Production

Materials and production sourcing are critical to the success of an apparel firm. Sourcing is procuring of materials and production at a specified quality and service level. It involves a series of planned management decisions that includes merchandising, production, and marketing managers. Decisions are based on product requirements, production capabilities, lead time, and quality. A basic decision in sourcing is either to produce or buy the desired product.

Making involves producing the fabric, components, and finishing the products in the firm's own production facilities. Buying involves contracting with another firm to produce the product. Make-or-buy decisions arise as the result of the development of new products, need for specialized equipment, unsatisfactory supplier or contractor performance, and increase or decrease in demand for established products.

12.6.3 Buyer Communication

After identifying a prospective buyer the next step is to communicate with those buyers. Communication may be through letters, fax or e-mails. A formal letter includes detailed profile of the company, address, contact details, production details, total employees, product details, existing buyers, annual sales turn over, accreditations, infrastructure etc. It should be followed up till the company receives a prospective enquiry from the buyer and consequent order conformation. An exporter should prepare to cover the overhead expenses that would be incurred during the initial stage. After getting the approval, the exporter would send samples and enquiries for future business relationship.

12.6.4 Enquiry and Sampling

Requisition sent by buyer asking price details of the product which they want to place the order is an enquiry. The general content of the enquiry may have the details of garment style, fabric, colour and assortment and proposed order quantity. An enquiry received from the

buyer may not be the confirmation of order placement. So the buyer will ask for samples of their enquiry along with the price before confirming the order.

12.6.5 Pre-Costing

After receiving an enquiry from the buyer the merchandiser has to do the pre-costing for the product which is mentioned in the enquiry. Pre-costing is the process of estimating the tentative price for the product. While doing costing various factors like style, fabric, colour and design, order quantity, current exchange rate and accessories have to be taken into consideration. The document that communicates all the details about a garment inside and outside a company is Specification sheet. After pre-costing, it is sent to the buyer as a reply to his enquiry. The importance of costing depends on its degree of accuracy and the quick response to the buyer.

12.6.6 Order Confirmation and Acceptance

Buyer will confirm the order, after the approval of fit sample and the price. It will be in the form of order sheet or purchase order from the buyer. It should be in a proper format duly signed with the office seal of the buyer. After receiving the order sheet, the exporter has to read it carefully and confirm the order acceptance by duly signing the order sheet along with the office seal of the exporter. Then the copy of the same should be sent to the buyer. It is always advisable to start the order after receiving the Letter of Credit (L/C) from the buyer.

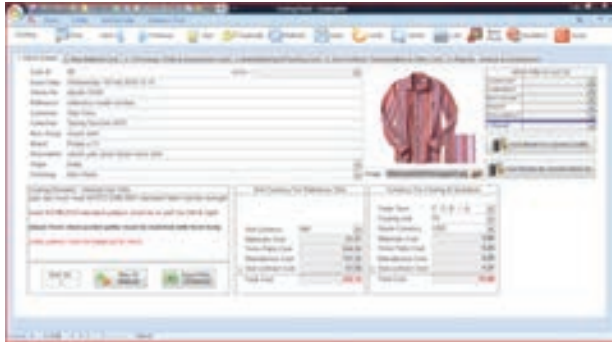

Figure 12.4 Order Form

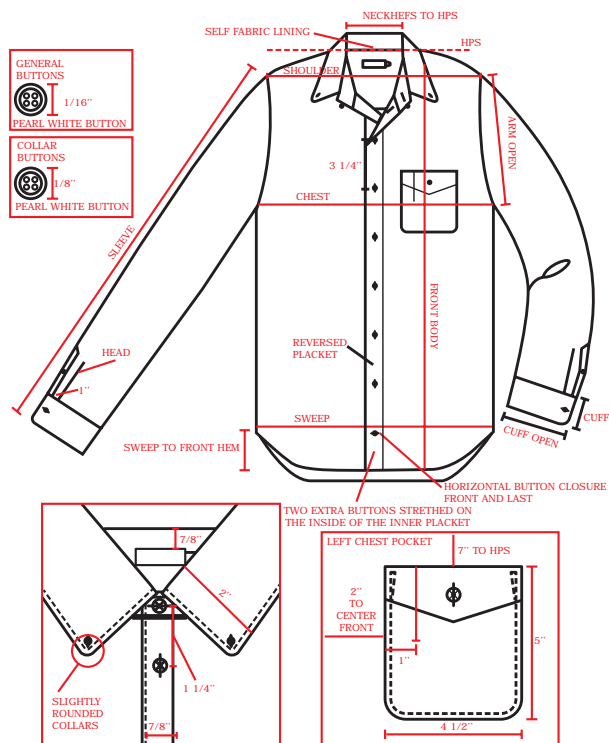

Figure 12.5 Specification Details

12.6.7 The Process of Order Review

Order review is going through or reading the order sheet carefully to check for the particulars with that of enquiry for any variations and also requirements of the particular order.

The order sheet have details like the quality requirements, packing details and accessories details. The merchandiser must check the quality, requirements

and note down the important instruction regarding label placement, wash care and spelling of words. Any discrepancies in the order sheet should be informed to the buyer at the initial stage itself and should be corrected before the commencement of the production. This is an important activity which would help in efficient and effective follow up and execution of the order.

12.6.8 Planning and Programming

Planning includes the time calculation and scheduling of the order lead time. Planning include master planning and scheduling or critical path. Programming involves decision making on certain activities in a particular order.

Master Planning

The total time required to complete the order is estimated. If not necessary alternatives to execute the order in time is also planned. The target date for shipment is set before master planning. The target date is normally set one week to ten days earlier than the delivery date mentioned in the order sheet. Yarn purchasing, fabric production, processing, cutting, sewing, checking, ironing, packing, final inspection and shipment departments need to be consulted regularly to know the progress of all these activities. Their available capacity details should also be noted. If the final inspection date falls on the target date then the order can be shipped in given time. If not, then the revised planning should be done by outsourcing or increasing the capacity levels for various activities.

Scheduling or Critical Path

It is the activity of giving time schedules to the various departments based on master plan. It will be in a table format which tells about the process sequence for a particular order and their corresponding schedules or timings or dates for each process from date of order confirmation till shipment. It consists of two main columns namely Planned and Actual. If there is any deviation in the planned and actual dates, then revised planning has to be done. The scheduling is also called as “Route Card”.

Programming

Apparel manufacturing involves a combined network of various activities like raw materials, purchase, knitting, weaving, processing and sewing. The decision on when, what, where, how and who has to be made for all these activities. Programming is the activity of deciding all these activities.

12.6.9 Samples

Sample is a product which represents a group, lot or batch. The quality, style, fit, design, workmanship or any other characteristic of the product are noted in every sample. Based on the samples the buyer gives approval or comments for any alteration in design or style or quality. Samples may be made before the start of the production or can be taken from the finished goods. For every order or style, separate samples are to be made. Different types of samples like original sample, offer sample, fit sample, proto sample, photo shoot sample, salesman sample, and size set sample, preproduction sample, production sample, shipment sample, fabric sample, accessories sample and document sample are made in apparel export.

12.6.10 Accessories Sourcing and Purchasing

Accessories can be generally classified into production accessories and packing accessories. Production accessories are the ones which becomes the integral part of the apparel. Packing accessories are those used in packaging of the apparel product which may be individual or bulk packing. If the accessories have to be purchased domestically from the exporters supply, then it needs approval from the buyer. If it has to be purchased from the suppliers abroad, the process need time. So accessories planning should be done at the earliest.

12.6.11 Inspection

Inspection is the visual examination or review of raw materials, partially finished components of garments and completely finished garments in relation to some standards specifications, or requirements. Here the garments are checked for the required measurements.

The principle involved in inspection is the early detection of-defects, feedback of this information to appropriate people. This helps in determination of the cause and ultimately correction of the problem. It is done under three sections namely raw material inspection, in-process inspection, and final inspection

● Raw Material Inspection

Fabric inspection is usually done on fabric inspection machines. Defects in a fabric can be seen readily with these machines, as the inspector has a very good view of the fabric and the fabric does not need to be reversed to detect the defects. These inspection

machines are either power-driven or the inspector pulls the fabric over the inspection table and check the defects.

- **In-process Inspection**

Inspection is done in between any process or in between any sewing operations. This may be in half finished (or) semi-finished stage. In – process inspection includes flip checking, patrol inspection, pre-final inspection and 100% Inspection.

Flip Checking

Inspection done by the operators or by its assistance during the sewing operation before the garments are bundled.

Patrol Inspection

Inspecting activities of a particular area or line. It is called as line supervision.

Pre-final inspection

It is done by the final Inspection merchandiser or QC or both can do pre-final Inspections. After pre-final Inspection garment are send to final inspection. After final Inspection only, the decision of passing or rejecting is made.

100% Inspection

Inspection should be done 100% in the Inspection center.

- **Final Inspection**

First time inspection of the packed merchandise goods is called original inspection. It is a random inspection done according to the customers individual required standard after the shipment have been completed packed and ready to ship. Colour appearance, workmanship and style will he checked against the customer's specification.

Testing

After fabric is received, certain properties of the materials are measured or evaluated using certain instrument or equipments. This process is called as Testing. Generally properties such as GSM, dimensional stability or shrinkage, pilling, streaks, lines, colour matching, strength and weight are tested before the production process.

12.6.12 Cutting and Production

This is a crucial stage in the apparel manufacturing process. Changes or problems cannot be rectified once the cutting process is done. So one has to make sure that certain things are completed or approved before proceeding the work. The following should have been approved before proceeding for production. This includes Size set samples approvals, Accessories, In-house Testing reports and Fabric inspection reports.

The apparel manufacturing involves combined network of various complex activities. In order to ensure the optimal execution of the order certain approvals are to be obtained during manufacturing process. They are

- Fabric approval
- Garment sample approvals at different stage
- Accessories approval
- Colour, design approval
- Packing approval
- Quality approval
- Quantity approval
- Time extension approval
- Factory approval
- Document approval

DO YOU KNOW? What is Ticketing in Garment Production?

In cutting process, while bundling cut parts, numbers or code called tickets are attached to all bundles. This will provide basic information about the bundle and the components in the bundle.

12.6.13 Packing

Packing should be done in accordance with the requirement of buyer as individual or bulk, type of packing material, number of units in each carton. The carton boxes are checked for the following points:

- Total number of cartons and their code numbers
- Shipping marks
- Packing slip details like order number, style name, number and other assortment details.
- Carton packing check like checking the method of packing, type of end joining.
- Number of carton boxes selected for inspection

Shipping marks are the symbols or logo which are given by the buyers and are to be printed on the carton boxes for easy identification. Besides the shipping marks the carton box should be written with the details of order which may be printed on the carton box or may be pasted with the packing slip.

12.6.14 Shipment

Shipment is the process of expediting the goods to the buyer through proper means of transport so that it reaches the buyer safely and on right time. The most common means of transportation are by

water, air, road or combination of these. Products are also transported by courier or post.

Various procedure and documents have to be prepared before shipment.

Every person importing or exporting goods requires an importer – Exporter Code Number (IEC). The export of goods is controlled by certain rules and regulations. Export of goods may require Export license, forwarding and clearing agent, shipping order, customs formalities, Excise clearance, Insurance, negotiation documents etc.

12.7 Buying Offices

The buying office provides not only market coverage, but also relates value of merchandise to the stores. It acts as the eyes and ears of the stores and provides the following information.

- Merchandise News
- Special items
- Reordering
- Fashion activity

The Buying Office Also Provides Counselling Services

- A good buying office provides personalized service to the store.
- To do this, knowledge of each stores merchandise unique character, clientele etc must be known.
- The buying office represents leadership to a group of smaller stores to compete with larger chains.
- The group buying activities benefits the smaller stores in reduction of prices for consultation, better delivery and availability of merchandise etc.



What is AEPC?

Apparel Export Promotion Council is the official Body of Apparel exporters.

It provides assistance to Indian exporters as well as importers / International buyers choosing India as their preferred sourcing destination for garments.

12.7.1 Types of Goods

Types of Merchandise Planning Process

- Staple/Basic Merchandise consists of items that are in continuous demand over an extended time period. Examples: salwars, kurtis
- Fashion Merchandise consists of items that are in demand for a relatively short period of time. New products are continually introduced into these categories, making the existing products obsolete. Examples: high-end women's apparel.
- A Fad is a merchandise category that generates a lot of sales for a relatively short time, often less than a season. Example : cowl collars, puff sleeve garments.

General Features of Staple Merchandise Categories

- Relatively easy to forecast demand and the consequences of making mistakes in forecasting are not great
- Predictability of demand makes it easy to plan for continuous replenishments
- Generating orders for inventory replacement can be automatic when the inventory falls below a pre-determined level

General Features of Fashion Merchandise Categories

- Forecasting of sales is much more complex
- Buyers for fashion category have much less flexibility in correcting forecasting errors.
- The attempt is to be as close to out of stock as possible at the same time that the SKUs become out of fashion
- Seasonal merchandise categories are treated more or less similar to the fashion merchandise and they consist of items whose sales fluctuate dramatically depending on the time of the year

12.8 Visual Merchandising



Figure 12.6 Store Display for Visual merchandising

Merchandise displays offer retailers non-personal ways of presenting products or information to consumers inside stores. It is common practice for wholesalers and sales representatives to set up and maintain displays of their products. This is one way that these suppliers can insure shelf space for their products, thus, they claim, benefitting both themselves and retailers. Retailers use displays to stimulate sales of products.

Visual Merchandising is the art of displaying merchandise in a manner that



is appealing to the eyes of the customer. It sets the context of the merchandise in an aesthetically pleasing fashion, presenting them in a way that would convert the window shoppers into prospects and ultimately buyers of the product. A creative and talented retailer can use this upcoming art to breathe in new life into his store products. Passion for design and creativity are essential to be a good visual merchandiser. A perfect design process and the ability to create ideas that are different are required. Awareness of happenings in fashion world is needed so as to keep up-to-date with the dynamics of the market constantly. Visual merchandising includes window displays, signs, interior displays, cosmetic promotions and any other special sales promotions taking place.

12.8.1 Elements of Visual Merchandising

Visual Merchandising is commonly accepted as a merchandising technique that uses the visual elements effectively. Visual element refers to lighting, colours and signage. In short, they are the visual communications in the designing of an environment. Some of common tools used for visual merchandising are:

- **Mannequins**

It is a full bodied dummy of human form and it is available in all age groups from children to adults. Mannequins are used by apparel retailers to display their products in-store and in the window display. They are a tool used to show consumers what their products look like on a person. The mannequins will commonly be styled to match trends as well display the latest products available.

- **Forms**

A form is an imitation of some part of a body. It is generally used on top of a stand and serves to display articles of clothing and accessories.

- **Colour** is a significant tool used in visual merchandising. It can be used to influence the behaviour of consumers and evoke different reactions. Colour is a powerful tool in exterior displays. It can aid creativity for exterior window displays and can have a unique effect on the consumer. The use of colour can create atmosphere, grab the attention of by-passers, and attract them to the store. Different colours can trigger different emotional responses.

- **Light** can be used in many ways in retail stores, from highlighting an object or area of a store to simply illuminate the entire store

- **Store Fixtures**

Most common types of fixtures: Stands, Platforms and Elevations, Round rack , Bin , T-Stand , Four way face out

- ❖ Stands

Stands used in a variety or assortment window from glass line to the back of the display window

- ❖ Platforms and Elevations:

Platforms or elevations can be tables and other pieces of furniture that can be used to rise up mannequin, a form or arrangement of merchandise

- ❖ Round Racks:

Circular racks on which garments are hung around the entire circumference

- ❖ Bin

A rimmed table or bin used to hold sale or special merchandise on the sales floor,



especially in discount operations; it has no formal arrangement

❖ T-Stand

Freestanding, two-way stand in the shape of that holds clothes on hangers, sometimes with one straight arm and one waterfall

❖ Four-way Stand

A fixture with four extended arms, that permits accessibility to hanging merchandise all the way around

❖ Music

The music played within a store can promote a brand's image, and can also aid consumers into making purchase decisions. Music that suits the style of the store and the target audience is an important factor to consider

12.8.2 Methods of Visual Merchandising

Visual merchandising includes mainly two types namely interior display and exterior display

Interior Display

The interior display should guide and persuade the customer to purchase. It includes

- Store Layout
- Store Design
- Display space

Visual merchandising also encompasses the design of a store layout. A store layout will be heavily influenced by the assortment and variety on offer and will be constrained by the size and structure of the shop itself. The layout used is determined or be dependent on the type of fixtures used. There are a number of different approaches to store layout, although they are all designed with the

intention of moving customers to every areas in the store in order to expose them to the full range of products.

Off-Shelf Displays

These displays are designed to have additional impact by showing the product as it might be used, or perhaps alongside other products to suggest complementary purchases. Displays can also be considered as visual features that create interest or excitement within the store.

Exterior Display

- Window Displays
- Store Front

Window displays have a particularly important role to play in communicating to the potential customer what the retailer stands for in terms of product and shopping environment. Window displays make customers aware of the type of merchandise being sold, and hopefully will attract the interest of target customers.

12.9 SUMMARY

Merchandising is considered as the core of marketing. It involves all activities in product development and selling. In garment manufacturing, merchandising is be divided as apparel and fashion merchandising. The most common activities are designing the product, getting the approval of the product and order, purchasing of raw materials, testing and quality assurance, packing, shipping the product, selling the product and finally satisfying the serviceability of the product. A merchandiser is the person who co-ordinates all these activities. The success of merchandising assures the success of the company, therefore great care should be taken in merchandising processes.

POINTS TO REMEMBER

- Merchandising is an important part of marketing and involves all activities necessary to determine and satisfy the wants and needs of a consumer.
- It is the planning and supervision involved in marketing a particular product and making it available at places, times, prices and in quantities that will best serve to realize the marketing objectives of a business.
- Apparel merchandising involves a constant watch of the production of the apparel products.
- The apparel supply chain involves five major sectors such as Fibres, Yarn sector, Fabric sector, Garment sector and Retail sector.
- Merchandiser is basically a co-ordinator, one who works between the buyer and apparel manufacturer to ensure quality merchandise at right delivery time.
- Merchandising involves all the activities right from communication to execution
- Garment manufacturing includes number of processes from order receiving to dispatching shipment of the finished garments. It includes merchandising department, sampling, fabric & accessories store department, spreading, marker planning and cutting department, sewing, washing department, quality control, pressing and folding, packing and despatching and administrative department.
- Categories of apparel merchandising includes Fashion merchandising, Apparel production or export merchandising and Apparel retail merchandising
- At every stage merchandiser has to co-ordinate with all the departments and follow up at every process
- Various steps in apparel merchandising includes fashion forecasting, sourcing , materials and production , buyer communication, enquiry and sampling, pre –costing, order confirmation and acceptance, order review, planning and programming, samples, accessories sourcing and purchasing, inspection, cutting and production, packing and shipment.
- Fashion Forecasting is the process of analyzing and predicting the future trends for the upcoming season in the industry
- Sourcing is procure of materials and/or production at a specified quality and service level
- Communication may be through letters, fax or e-mails
- Requisition sent by a buyer asking price details of the product which they want to place the order for, is an enquiry
- Pre-costing is the process of estimating the tentative price for the product. While doing costing various factors like style, fabric, colour and design, order quantity, current exchange rate and accessories have to be taken into consideration
- Planning includes the time calculation and scheduling of the order, the lead time
- Accessories can be generally classified into production accessories and packing accessories
- Sample is a product which represents a group, lot or batch.

ACTIVITIES FOR TEACHER

- To list the apparel categories and sizes for women, men and children.
- Collect and show sample types and details developed during apparel manufacture and export

ACTIVITIES FOR STUDENTS

- To collect the list of apparel manufacturing centres in India.
- Collect pictures of different techniques in visual merchandising and prepare an album

A-Z GLOSSARY

Apparel merchandising	The planning, development, execution and delivery of a product line based upon the needs of a target market.
Style	It is the characteristic or distinctive appearance of a garment that makes it different from other garments. Ex. styles of skirts: mini, midi, long etc.
Design	A detailed version of a styles
High fashion	The style and designs accepted by a limited group of people who adapts the first change in the fashion and considered as fashion leaders. Produced in small quantities and sold at high prices.
Marketing	Identifies the customer and determines what products to offer that customer and how to do so while meeting the financial return objectives of the company.
Mass fashion	The styles and designs that are accepted by a mass number of people who are considered as the followers of fashion leaders. They are manufactured in large quantities and sold at competitive prices.
Taste	It is an opinion of a person or individual about the aptness of a fashion for a given situation
Accessories	Items such as shoes, scarves, stockings, jewellery, hats and purses which should coordinate with and enhance the appearance of a fashion garment.
Classic	A fashion which lasts for a longer period of time
Collection	A group of samples of a designer's or manufacturer's designs for a particular season.
Fad	A novelty item or style that is popular for only short time

QUESTIONS AND ANSWERS

PART – I

Objective Questions

1. Merchandising is the process through which products are planned, developed executed and presented to _____.
 a) Producer b) Retailer
 c) Buyer d) Wholesaler
2. The office that communicate with buyers of other countries and garment manufacturing factories who fulfill buyer's demand
 a) Agent office b) Buying office
 c) Agents d) Brokers
3. Merchandise that should be always be stocked throughout a year or season due to popular demand
 a) Basic stock
 b) Classic
 c) Fad merchandise
 d) Fashion merchandise
4. A written document authorizing the delivery of certain goods at specific prices and times
 a) Order sheet
 b) Order document
 c) Purchase
 d) Re-order
5. The visual examination or review of raw materials, partially finished and completely finished garments in relation to some standards.
 a) Testing
 b) Inspection
 c) Quality control
 d) Checking



PART – II

Answer in Three (Or) Four Points

1. Define apparel merchandising.
2. What is sampling?
3. What is meant by scheduling?
4. Describe pre costing.
5. Write about flip checking.

PART – III

Answer in a Paragraph

1. Differentiate Merchandising and Marketing.
2. List the functions of merchandiser.
3. Explain the activities carried out in spreading and cutting department.
4. Discuss about programming and Planning.
5. Write about different store fixtures in visual merchandising.

PART – IV

Answer in One Page

1. Explain the importance of merchandising in apparel industry.
2. Describe the various departments in an apparel unit.
3. Discuss the steps in merchandising process.

Answers for Objective Questions

1. (c) 2. (b) 3. (a) 4. (c) 5. (b)

CHAPTER

13

Entrepreneurship
Development

LEARNING OBJECTIVES

- To understand the concepts and types of entrepreneurs
- To identify and formulate the project for entrepreneurship
- To adopt the method for setting up small scale units
- To understand the meaning of quality assurance and its importance
- To know the potentialities of women entrepreneur

13.1 Introduction

Entrepreneurship plays an important role in the economic growth of the country. Entrepreneurship means doing something in an innovative and effective way. It is a dynamic process of creating wealth by individuals or groups by the use of various resources. Entrepreneurship helps one to start his or her own business. It also lays the foundation for women to become empowered.

The word entrepreneur is derived from the French word 'entreprendre'. It means to undertake. An entrepreneur is a person who establishes his own business or industrial undertaking with a view to make profit. An entrepreneur is one who combines various factors of production such as process and raw material, and then converts the raw materials into finished product. He sells the finished product in the market to earn profit. He can also be described as a person who innovates, raises money, assembles input, chooses managers and sets the commercial organization. Entrepreneurs are people who initiate, organize, manage and control the affairs of a business unit to supply goods and service.

13.2 Entrepreneur

13.2.1 Definition

Entrepreneur is an individual who bears the risk of operating a business in the face of uncertainty about the future conditions.

- *Encyclopedia Britannica.*

An entrepreneur in an advanced economy is an individual who introduces something new in the economy, a method of production not yet tested by experience in the branch of manufacture concerned, a product with which consumers are not yet familiar, a new source of raw material or of new market and the like.

- *Joseph Schumepeter.*

Who is an Entrepreneur?

“An entrepreneur is a person who undertakes to do a job”

- *Richard Cantillon*

“An entrepreneur is a person who acts as agent in *transforming* demand into supply”

- *Adam Smith*

“An entrepreneur is a person who shifts resources from an area of low productivity to high productivity”.

- *Jean Babtiste*

DO
YOU
KNOW?

Who was the first Entrepreneur?

George Washington was the first U.S. president, a celebrated military general and also a keen businessman and entrepreneur. But his business smarts have essentially been forgotten by historians and the public, even though Washington's face can be seen plastered across the U.S. currency. A new book called *First Entrepreneur*, shines a light on Washington's business-minded accomplishments, which helped to set up the nation for future success.



13.2.2 Qualities of an Entrepreneur

The qualities essential to become a successful entrepreneur are;

- **Risk bearer** - bears problems or hard times in the business
- **Opportunity explorer** - identifies means and ways to achieve the goals
- **Achiever** - self determined to achieve the goals in business
- **Individualist** - job giver and not job seeker
- **Flexible person** - ready to take decisions based on the prevailing situations and expect changes as and when needed
- **Motivator** - influences people and make others to think and act accordingly
- **Stress taker** - discusses physical and emotional stress and helps others to solve them
- **Planner** - frames step by step activities and follows them to achieve the goal of the company or unit
- **Problem Solver** - thinks logically and tries to solve problems systematically
- **Creative thinker** - Analyses the current trade situations and comes up with creative ideas ‘**Out of Book Thinking**’

13.2.3 Types of Entrepreneur

The types of entrepreneurs are innovative entrepreneur, adoptive or initiative entrepreneur, fabian entrepreneur and drone entrepreneur.



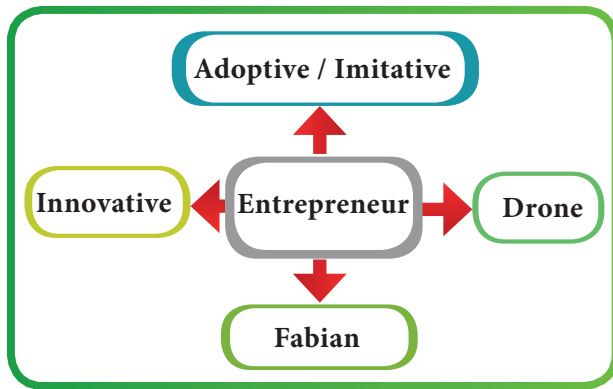

Figure 13.1 Types of Entrepreneur

13.2.3.1 Innovative Entrepreneur

These entrepreneurs are generally aggressive in experimentation. They are found in developed countries. They are highly creative. They do attractive things in their business. They keep introducing new techniques or products into the market. They play a key role in rise of modern capitalism. They face the risk of uncertainty.

13.2.3.2 Adoptive / Imitative Entrepreneur

These entrepreneurs are adoptive as they are ready to adopt successful innovations created by innovative entrepreneurs. They do not innovate changes but imitate the technology, knowledge and skills found by others. They are found in under developed countries as they contribute to the development of economics. They face lesser risks and uncertainty than innovative entrepreneurs.

13.2.3.3 Fabian Entrepreneur

These entrepreneurs are very cautious and are very lazy. They are not ready to introduce new changes and do not adopt new methods innovated by the most enterprising entrepreneurs. They are not interested to take risks and they follow the footsteps of their predecessors.

13.2.3.4 Drone Entrepreneur

These entrepreneurs are conventional. They refuse to adopt and use opportunities to make changes in production. They do not make changes in their methods even if there is a loss in business. They are laggards because they try to continue their job in their traditional way. When their products become uneconomical, they will be pushed out of the market.

13.2.4 Functions of an Entrepreneur

The functions of entrepreneurs are:

- Perceiving market opportunities
- Marketing of the products to overcome competition
- Purchasing inputs and industrial engineering
- Upgrading process and product quality
- Managing money, man, material and machines
- Understanding licence and taxation procedures.

13.3 Entrepreneurship

Entrepreneurship is a process of identifying and starting a business venture, sourcing and organizing the required resources and taking risks associated with the venture.

Entrepreneurship has been defined in several ways and is considered as :

- A theory of evolution of economic activities
- A continuous process of economic development
- An ingredient to economic development
- Essentially a creative activity or an innovative function

- A risk taking factor which is responsible for an end result
- Usually understood with reference to individual business
- Name given to the factor of production which performs the functions of an enterprise
- Creates awareness among people about economic activity
- Generates self-employment and additional employment.

13.4 Project

Project is the foundation for any company. It is a technical document which approves the activities of a company. It indicates the unit product intermediate or end products to be sold in the market. It has to be planned carefully based on the market forecast. It helps an entrepreneur to apply for loan.

- Project is defined as a non-routine, non-repetitive, one-off undertaking normally with discrete time, financial and technical performance goals –**Harrison**.
- A project is a scientifically evolved work plan devised to achieve a specific objective within a specified period of time. The project may differ in size, nature, objectives and complexity.
- A project is an approval for a capital investment to develop facilities to provide goods and services defines **World Bank**.
- Projects are classified as quantifiable and non-quantifiable projects, sectoral projects, techno-economic projects and financial projects.

13.4.1 Project Life Cycle

The project life cycle consists of three main stages as shown below :

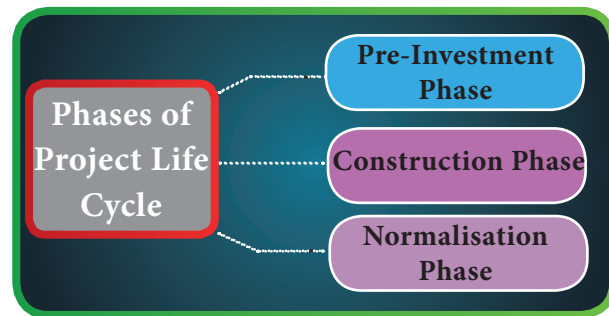

Figure 13.2 Project Life Cycle

● The Pre-Investment Phase

The first phase of the project is pre-investment. It is concerned with objective formulation, demand forecasting, selection of optimal strategy, evaluation of input characteristics, projections of the financial profile, cost benefit analysis and pre investment appraisal. The project idea is developed into an investment proposition during this phase.

● The Construction Phase

The construction phase begins after the investment decision is done. The assets like land, buildings, machinery, communication services, control systems etc. are purchased by investing the resources. The development of the infrastructure for the project is the main concern in this phase.

● Normalisation Phase

Normalisation Phase starts after the trial is made during the construction phase. The primary objective of this phase is to produce the goods and services for which the project was established. The assets created during the construction phase are utilised during the normalisation phase.

13.4.2 Project selection and formulation

The criteria used for project selection are;

- Investment size
- Location
- Technology
- Equipment
- Marketing
- Power and water
- Working capital requirements
- Labour component
- Economic viability

Project formulation is the systematic development of a project idea. It involves the joint efforts of a team of experts. It would be helpful if government clearance is obtained. It is an analytical management aid. It can be shown to the bankers or other institutions to acquire financial assistance. It is prepared by an expert after detailed study and analysis of the various aspects of a project.

13.4.3 Project Report preparation

The major steps involved in project report preparation are;

Step 1: Choose an idea for the enterprise.

The idea selected should be viable, profitable and socially good. These ideas can be acquired from various sources such as magazines, journals, competitors, employees, distributors, customers and through research.

Step 2: Observations have to be made with regard to the availability of raw material, labour, machinery, technology and demand in the market.

Step 3: Scanning of business environment is the next step. The amount of money required for investment is scanned thoroughly, location of enterprise, labour availability and the extent of marketing are also scanned.

13.5 Accounting and Book Keeping

Every enterprise irrespective of whether it is large or small, public or private, sole or partnership has financial concern and wish to make profits. It is humanly impossible to remember all the transactions. So there is a need to record them. Accounting is said to be the language of business as it communicates or reports the results of business operations. Accounting is described as the art of recording, classifying and summarising in a significant manner and in terms of money, transactions and events which are in part of financial character and interpreting the results thereof.

The scope of accounting comprises of the following heads :

● Data Creation and Collection

Every transaction related to some financial activity is noted and recorded into books. This may be done in manual, mechanical or electronic way. Years back it was done manual and books or physical files were maintained. But in the recent years computers are used and electronic files are maintained. Important files are locked with suitable password.

● Data Evaluation

Data Evaluation controls the activities of business, evaluating the

performance of the business and analysing the accounting information for decision making purposes. This activity helps the company to start new product production or modify the existing product.

- **Data Reporting**

Data Reporting consists of two parts namely external and internal reporting. External reporting is the communication of financial information to the outside portion. Eg. : Shareholders and government agencies. Internal reporting is concerned with the communication of results of financial analysis to the management for decision making purposes.

- **Accounting**

The accounting system has two stages namely book-keeping and accounting. Book Keeping is a process of maintaining routine records in prescribed form and according to set rules, of all events which affect the financial state of the organisation. Accounting is the summarisation from time to time of the information contained in the records, its presentation in a significant form to interested parties, and its interpretation as an aid to decision making by these parties.

Accounting is carried out in four steps or stages namely recording the transactions, classifying the transactions, summarizing the transactions and interpreting the transactions.

- ❖ **Recording the Transactions**

All business transactions are first recorded in the book of original entry with the help of cash memos, cash receipts and invoices. This book is known as “The Journal”. All the business transactions are entered in a chronological order. Books of primary entry are Journal and subsidiary books and books of final entry is the “ledger”.

Table 13.1 Proforma of a Journal

Date Column	Particulars	Ledger Folio	Debit	Credit
Date of Transaction	Entry with narration	Posting Reference	Amount debited	Amount credited

- ❖ **Classifying the Transactions**

Transactions of similar nature are grouped together and posted into another book called “The Ledger”. The purpose of classifying the transactions of similar nature is to understand their combined effect. For this purpose all such ledger accounts are balanced for a particular period of time.

Table 13.2 Proforma of Ledger Account

Debit				Credit			
Date	Particular	J.F.	Amount	Date	Particular	J.F.	Amount
Date of transaction	To Name of the Account	Posting Reference Number		Date of the Transaction	By Name of Account	Posting Reference	
Beginning of the Month / Year	To Balance b/d			End of the Month / Year	By Balance c/ d		

❖ Summarising the Transactions

Summarising the Transaction is the preparation of the year end summary known as “Final Accounts”. Before preparing final accounts, a list of all ledger balances are prepared in the form of a statement known as “Trial Balance”. Final accounts consist of trading and profit and loss, Account and Balance Sheet”. Trading, profit and loss account reveals the net result of the business. The balance sheet depicts the financial position of the business.

❖ Interpreting the Results

The final stage is to analyse and interpret the results as per the final accounts. This includes computation of various accounting ratios to assess the liquidity, solvency and profitability of the business. This helps the entrepreneur understand all the activities of the company, financial status and plan for the future of the company.



Who was the first to start Accounting?

The Italian Luca Pacioli, recognized as The Father of accounting and book keeping was the first person to publish a work on double-entry book keeping and introduced the field in Italy. The modern profession of the chartered accountant originated in Scotland in the nineteenth century. Accounting began to transition into an organized profession in the nineteenth century, with local professional bodies in England merging to form the Institute of Chartered Accountants in England and Wales in 1880.



13.5.1 Trial Balance

It is a statement containing the balances of all ledger accounts as on given date. It is prepared to check the arithmetical accuracy of the ledger postings.

13.5.2 Financial Statements

The purpose of financial accounting is to keep records of all the financial transactions so that profit earned or loss incurred can be worked out. Financial position of the business can be ascertained and the financial information required can be provided. The financial statements primarily include trading and profit and loss account balance sheet and Generally Accepted Accounting Principles (GAAP) state that a complete set of financial statements must include:

- Profit and Loss Account or Income Statement,
- Statement of Retained Earnings,
- Balance Sheet, and
- Statement of changes in Financial Position.

13.5.2.1 Fund Flow Statement

It is an important analytical tool in hands of the management useful for analysing the past and planning for the future. It is useful in following and many more aspects;

- It serves as a control device
- It helps in proper allocation of resources
- It helps in the management to formulate financial policies
- It communicates valuable information regarding concerns financial position to outside world

- It enables the investors and creditors in assessing the degree of risk involved in granting credit or associating with the business.

13.6 Steps to Start Small Industrial Unit

The steps to be taken by entrepreneurs to start a small industrial unit are explained under the following heads;

13.6.1 Selection of the Product

The product selection is made by an entrepreneur according to his or her own capacity and motivation. One may design a new product or may imitate others products. The economic viability of the product should cover the demands such as

- Volume of existing demand in the domestic market and export market
- Volume of potential demand
- Degree of import substitution and substitution of an existing product and
- Volume of demand by big units for ancillary products.

Some of the most common small scale enterprises in our country are based upon the day to day needs such as readymade garments, leather foot wear, detergent soaps, detergent liquids, plastic items and food items like squashes, marmalade, pickles, jellies, jam and macroni.

13.6.2 Selection of form of ownership

The most commonly chosen forms of ownership for Small Scale Industries (SSI) are Sole Proprietorship, Family Ownership, Partnership and Private

Limited Company. Sole Proprietorship and Family Ownership have unified control over the unit whereas Partnership and Private Limited Company facilitate the pooling of financial resources, managerial and technical skills.

13.6.3 Selection of Site

The selection of site is planning a suitable plot for the factory or unit while selecting a site. An entrepreneur should see to that the site enjoys government incentives, it is located near the market, it is easier to avail labour and procure raw material. Also it is good to note that the site has modern infrastructural facilities.

13.6.4 Designing Capital Structure

For a new venture the initial capital comes from the sources such as own capital, long term loans and short term loans. Bank plays a very important role in providing working capital to all companies or factories or units.

13.6.5 Acquisition of Manufacturing Know-how

Several institutions like government research laboratories, research and development divisions of industries or individual consultants provide the manufacturing know-how for the young entrepreneurs. This methodology is also provided by the machinery suppliers both domestic as well as foreign. Also the national laboratories and research institution give guidance related to the know-how of productions and operations.

13.6.6 Preparation of Project Report

The project is prepared as per the format of the loan application of leading institution. It covers the aspects like sources of finance (long term and short term), availability of machine, technical know-how, sources of labour, and sources of raw materials, market potentiality and overall profitability. All the aspects are systematically estimated and presented.

The project report compiled by the entrepreneur should provide a 'Birds-eye-view' of the entire spectrum of the activity. It should give all information about the following aspects;

- **Technical Feasibility** - Power supply, water availability, transport facilities and communication network
- **Economic Viability** -Share market, revenue, suitable price structure and market forecast.
- **Financial Implications** - This comprises of recurring and non-recurring expenses. The recurring expenses include working capital, raw material needs, and wages for personnel, transport and power. The non-recurring expenses include land, buildings, plant and machinery.
- **Managerial Competency** - All the major economic activities of the company are included under this head.

13.6.7 Registration

An entrepreneur, after deciding upon a suitable product can establish an industrial unit. For this he or she must first issued a provisional (temporary) Small Scale Industry (SSI) Registration Certificate.

This certificate is provided for one year and subsequently renewed for two periods of six months each. An extension of the provisional registration may also be given. Permanent Registration Certificate may be given for the industrial unit which has commenced production.

13.6.8 Obtaining Statutory License

The next step is to obtain Municipal License Registration with Central and State Sales Tax Departments. This is important to know about the sales made by each unit which in turn will denote the economic growth of the country. An entrepreneur should study the procedure completely for accounting sales to those departments and returns have to be submitted regularly.

13.6.9 Power Connection

The new entrepreneur should pay security deposit amounting to three months power connection. Formal application should be submitted to get power connection. There are categories of power supply namely Low Tension (LT) and High Tension (HT). To get power connection the entrepreneur has to make an application to the Assistant Divisional Engineer, Tamil Nadu Electricity Board.

13.6.10 Arrangement of Finance

The fund requirements for a project may be for long term and short term. Long term loans are used for acquiring assets like land, machinery and building, and short term loans are used as working capital, repayment for loans, bill discounting and in meeting day to day needs of the industry.

Loans for fixed assets are provided by the State Financial Corporation and Commercial Banks. Apart from this, these loans are based on company status, assets belonging to the entrepreneur and his possibilities for repayment.

13.7 Concept of Quality

Quality of a company can be rightly called as the heart of the company and its assurance as life line. Quality control may be defined as the systematic control of all the variables influencing the quality of the final product.

- Joseph M. Juran defines Quality as the fitness for use or purpose.
- W.Edwards also describes Quality as predictable degree of uniformity and dependability at low cost and suited to market.
- The totality of features and characteristics of a product or service that bear on its ability to satisfy or implied needs of customers is the definition of quality as stated by ISO 9000.

Quality assurance means the degree to which the product actually confirms to the design specification which means manufacturing specifications of the product. This involves appearance, life, safety maintenance and other features of the product. Uniformity and acceptable quality of a product predicts the quality assurance of the product.

These two concepts of quality control and quality assurance lay a foundation for the development of the company. To a lay man, quality is proper use of the product till its lifetime as stated by the company.

Total Quality Management commonly known as TQM is also called Total Quality Improvement or Total Quality Control. This process starts from selection of raw materials which also includes safety measures and finally evaluation, packing and despatch.

Better quality gives better productivity. So the entrepreneurs have to devote their time for research

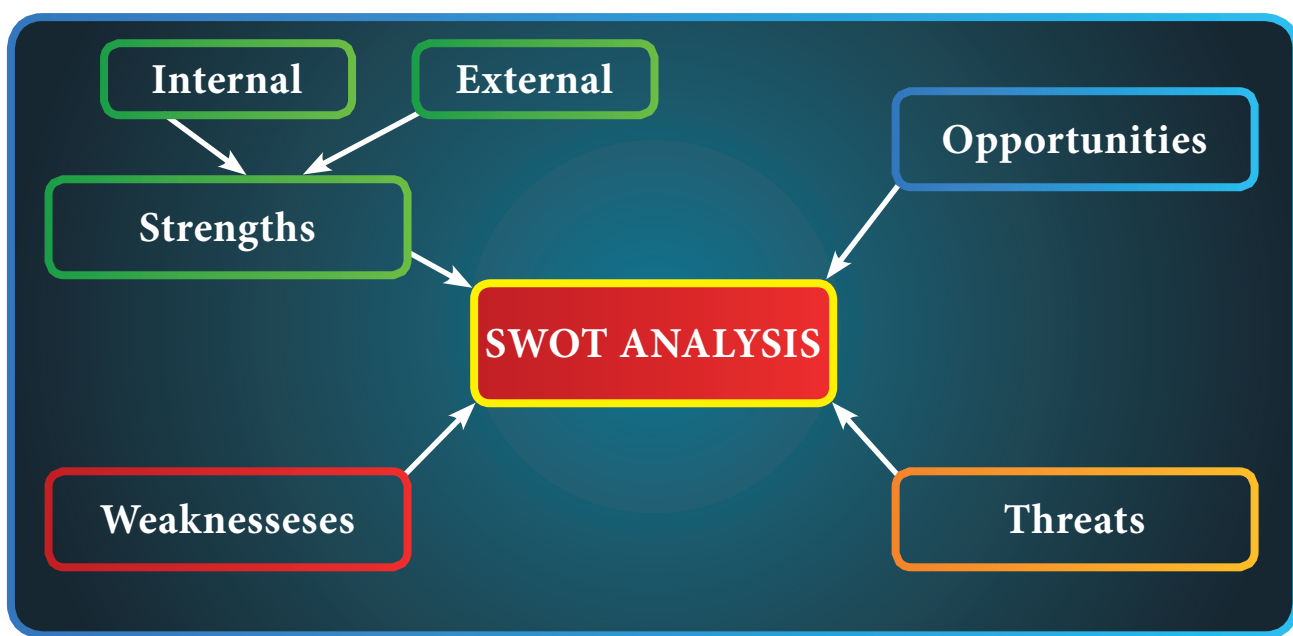

Figure 13.3 Concept of Quality

and development. The analysis made for external and internal environment together is called **SWOT** analysis. It refers to identifying of Strengths and Weaknesses of the Organisation and Opportunities and Threats of the environment.

13.7.1 Techniques and Benefits of Quality Control

There are two techniques of quality control and assurance. They are inspection and statistical quality control.

Inspection implies comparing quality characteristic of a product with predetermined standards or accepted specifications of quality. It is concerned with quality of design. It is a verification covered out after the product is manufactured. It ensures the standard of a product to be supplied to the customers.

Statistical Quality Control regulates the process of manufacturing to take corrective action for producing standard products. It is concerned with quality of conformance. It is defined as the technique of applying statistical methods based up the mathematical theory of probability to quality control problems. It is done with the purpose of establishing quality standards and maintaining adherence to those standards in the most economical manner.

Following are the benefits of quality control;

- It minimises the wastage and scrap
- Increases the process efficiency
- Reduces labour cost
- Improves the quality of the product and services
- Improves the sales turnover

- Increases customer satisfaction
- Reduces inspection cost and customer complaints
- Improves the operating efficiency of quality consciousness
- Conserves manpower resources
- Determines prices at competitive level and increases the profit.

13.8. Women Entrepreneurs

“When women moves forward; the family moves, the village moves and the nation moves” said by **Pandit Jawaharlal Nehru**.

Women entrepreneurs are those who venture out into industrial activities. They take the lead and organize the business or industry and provide employment to others. They are key players in economic development of the country. Indian women have increasing opportunities in higher levels of education, economic necessities and constitutional rights.

The knowledge of dress designing lays a strong foundation for women entrepreneurs. “A women entrepreneur can be defined as a confident, innovative and creative woman capable of achieving self-economic independence individually or in collaboration, generates employment opportunities for others through initiating, establishing and running the enterprise by keeping pace with her personal, family and social life” - **Kamal Singh**.

Need for women entrepreneurship;

- Women occupy almost 50% of the population, hence to attain complete development they must also take up jobs or become entrepreneurs
- To raise the status of women in society

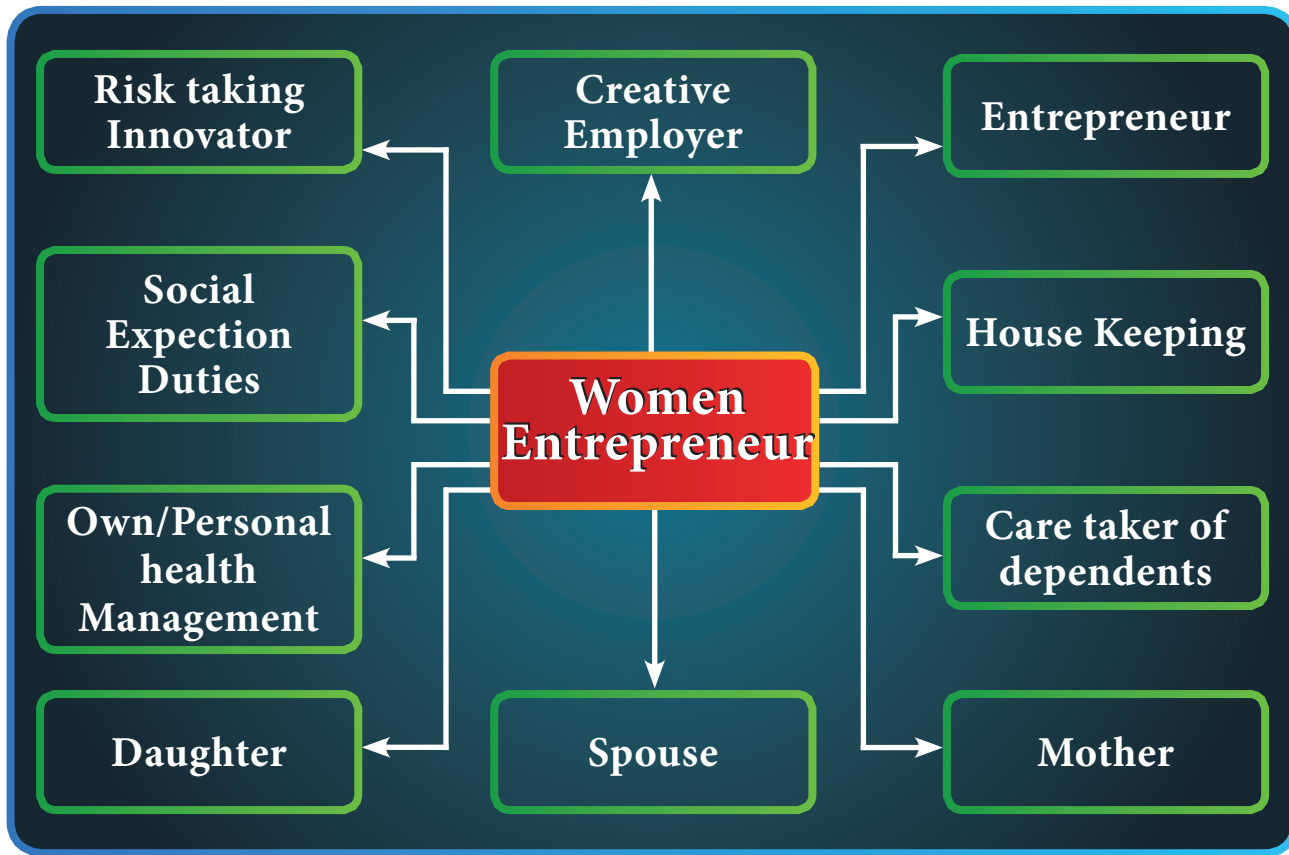

Figure 13.4 Multiple roles of Women Entrepreneur

- Economic and social development of women will also lead to the political development of the country.

The women entrepreneurs play multiple roles doing various activities at home as well as in the working spot thereby satisfying every one. The figure 13.4 above shows the multiple roles of a women entrepreneurs

Women start an enterprise due to economic and non-economic reasons. Some of the reasons for a woman to start an enterprise are stated below;

a. Motivational Factors

The motivational factors which encourage women to set up an enterprise are;

- economic necessity
- self-realization

- independence
- Government policies and programmes
- education
- employment generation
- social status
- success stories of friends and relatives
- family occupation and
- role model to others.

b. Facilitating Factors

The facilitating factors which influence the women to set up business are;

- contacts and networks
- family cooperation
- skilled people at work
- innovative thinking
- adequate financial facilities and
- self satisfaction.

13.8.1 Problems of Women Entrepreneurs

Various problems faced by Indian women who strive hard to become entrepreneur are as follows;

13.8.1.1 Financial Problems

Obtaining support of bankers, managing working capital, lack of credit resources are the problems which remain in the male domain.

13.8.1.2 Shortage of Raw Materials

They encounter problems of shortage of raw materials. This is due to inadequate facilities.

13.8.1.3 Credit Facilities

Women are often denied credit by bankers on the ground of collateral security. So women's access to risk capital is limited.

13.8.1.4 Marketing Problems

Women entrepreneurs face the problems in marketing their products. This area is mainly dominated by males. The elimination of middlemen is difficult and the women entrepreneurs are unable to capture the market and make their products popular.

13.8.1.5 High Cost of Production

High cost of production brings down the efficiency and stands in the way of development and expansion of women's enterprises. The problems faced are labour, human resources, infrastructure, legal formalities, overload of work, lack of family support etc.

13.8.1.6 Social Barriers

Women are seen with suspicious eyes, Particularly, in rural areas they face this

problem. The issues related to caste and religion also influence the opportunities for women entrepreneurs.

13.8.1.7 High Competition

Most of the women enterprises have imperfect organizational set up. They are facing severe competitions from organized industries.

13.8.1.8 Lack of Information

Women entrepreneurs lack knowledge and information about the availability of raw materials, financial facilities, government schemes and various kinds of subsidies available. This hinders the expansion of their markets.

13.8.1.9 Lack of Self-Confidence

Due to lack of self-confidence, they hesitate to take risks. Their risk bearing capacity is less. Not only women entrepreneur but also the men entrepreneur face certain problems in initiating and running the business on their own. For overcoming such obstacles one has to attend the entrepreneurial developmental programmes for obtaining appropriate training.

13.9 Entrepreneurial Development Programme (EDP)

Success of an entrepreneurship depends on the foresight, knowledge, optimum hard work, persistence and efficient management. The knowledge about various aspects of business can be acquired from the entrepreneurial development programme. The government plays a positive role in the emergence and development of entrepreneurship by providing training, incentives and concessions.

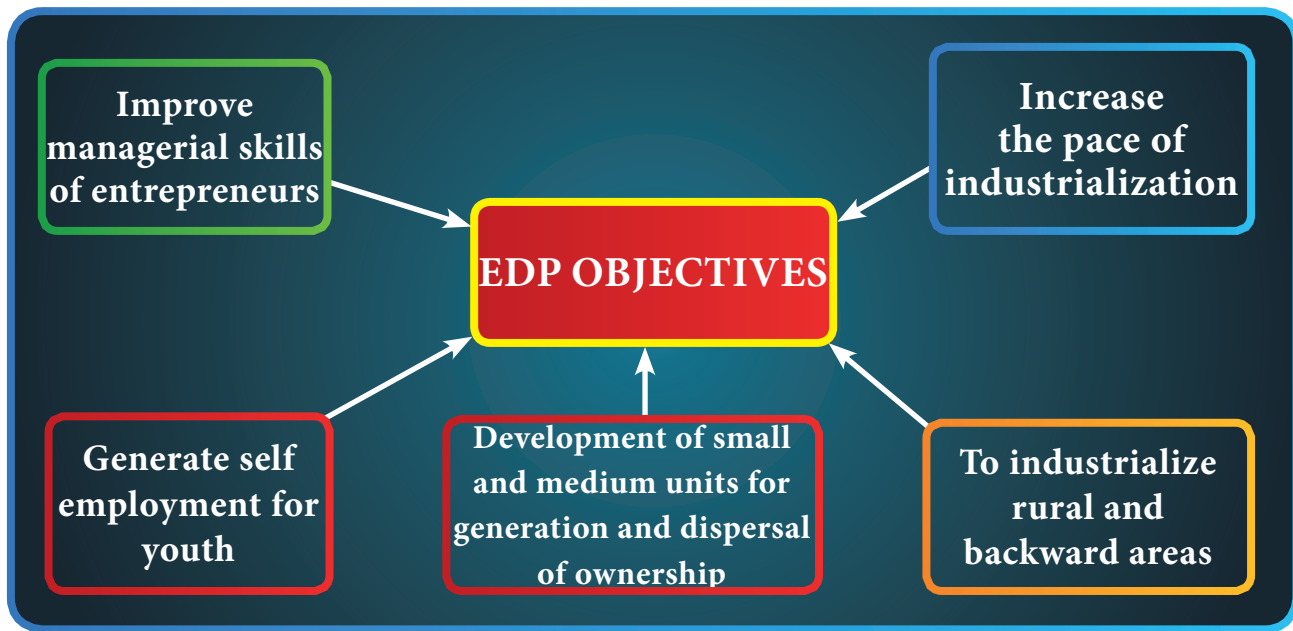

Figure 13.5 Objective of Entrepreneurial Development Programmes (EDP)

Entrepreneurial development programme may be defined as “a programme designed to help an individual in strengthening his or her entrepreneurial motive and in acquiring skills and capabilities necessary for playing the entrepreneurial role effectively”.

The objective of entrepreneurial development programme is presented in the figure 13.5

13.9.1. Need for Entrepreneurial Development Programme

Entrepreneurial Development Programme is needed for the following reasons;

Eliminate Poverty and Unemployment

Most of the under developed countries are facing the problem of unemployment. The EDP can help in creating self-employment for the unemployed. The programmes initiated by the government for managing the problem of unemployment are as follows

- NREP (National Rural Employment Programme)
- IRDP (Integrated Rural Development Programme)

Prevents Industrial Slums

EDPs help in removal of those slums as the entrepreneurs are provided with various schemes, incentives, subsidies and other infrastructural facilities. It helps in controlling overcrowding in the developed areas.

Balances Regional Development

Successful entrepreneurial development programme helps in accelerating the industrialization which results in reducing the concentration of economic power. It aims at promoting Small Scale Units which are useful for balanced regional development.

Use of Locally Available Resources

The entrepreneurial development programme helps in controlling and utilizing the locally available resources

through training and educating them. EDPs also help in minimizing excessive scraps and wastage in the production process.

Ease Social Tension

Entrepreneurial development programmes help in channelizing the talents and energies of unemployed youth. It helps and teaches the entrepreneurs to create self-employment thereby easing social tension amongst youth.

13.9.2 Phases of Entrepreneurial Development Programme

There are three broad phases of Entrepreneurial Development Programme. They are as follows;

Pre-Training Phase

The success of EDP depends on the training carried out by the training organization. Various activities undertaken by an organization are

- designing of course curriculum
- selection of faculty
- insertion of advertisement and
- selection of potential entrepreneurs.

Training Phase

During this phase, the participants are motivated and required skills are developed in them. They are also given practical exposures in the areas like market surveys, project preparation, report feasibility and marketing of products and services. This training is imparted by methods such as individual training, group training, and lecture method, written instruction method, demonstration method, conference method and meetings.

Post Training or Follow up Phase

This phase aims at developing the right type of ability and motivation amongst potential entrepreneurs so as to enable them to set up their own enterprises. Through follow-up, the weakness and problems may be remedied in the future. Appraisal helps in understanding the extent of which the entrepreneurs have selected suitable jobs. It guides them to identify right type of project. It also aims in promoting the entrepreneurial talents.

13.9.3 Role of government in developing entrepreneurship

Government has taken so many efforts in developing entrepreneurial programme through various agencies and institutions. They are as follows;

Institutions at National Level

- National Institute for Entrepreneurial and Small Business Development (NIESBUD)
- Entrepreneurial Development, Institute of India (EDI)
- Technical Consultancy Organisation (TCO)
- Indian Investment Centre (IIC)
- Small Industries Development Corporation (SIDC)
- Industrial Development Bank of India (IDBI)
- Industrial Finance Corporate India (IFCI)
- Industrial Credit and Investment Corporation of India (ICICI)
- National Small Scale Industrial Development Corporation (NSSIDC)

- Small Industrial Development Bank of India (SIDBI)
- Khadi and Village Industrial Centre (KVIC)
- National Bank of Agencies and Rural Development (NABARD)
- National Institute of Small Industries Extension Training (NISIET)
- Science and Technology Entrepreneur Part (STEP).

Institutions at State Level

- Small Industries Service institute (SISI)
- District Industries Centre (DIC)
- State Finance Corporation (SFC)
- State Small Industrial Corporation (SSIC)
- State Industrial Promotion Corporation (SIPC)

13.10 Summary

An entrepreneur is an economic agent who plans, organizes, makes decision and takes risks. Entrepreneurs are essential for economic development of a Nation. Entrepreneurship works in different ways in different economic situations. Government has taken several steps and introduced schemes for the men as well as women entrepreneurs. Several financial institutions assist and motivate the entrepreneurs. A person can very easily do his/her own business by understanding the rules and regulations, and initiate a small scale unit. Self employment brings self respect for a woman. Women entrepreneur balances both home as well as the business. Entrepreneurship development programmes and training programmes help in locating the developing the entrepreneur based on their suitability and brings success for them.

POINTS TO REMEMBER

- An entrepreneur is a job giver and not a job seeker.
- Self employment brings self respect, confidence and happiness for women.
- On the basis of the information collected through SWOT analysis, the goals which the firm wants to achieve in future can be decided.
- Entrepreneurs act as catalytic agents in the process of industrialization and economic growth.
- Training programmes are organized to enrich and upgrade the knowledge of the young and skilled entrepreneurs.

ACTIVITIES FOR TEACHER

- Can play a skit involving students for bringing the advantages of becoming an entrepreneur (women).
- Can show the videos about the struggles faced by successful entrepreneurs.
- Can make the students to study on the personalities of an entrepreneur.

ACTIVITIES FOR STUDENTS

- Can read and collect some case studies adapted to the successful entrepreneurship and prepare an assignment.
- Can collect information about any one of the institution which helps in the development of entrepreneurship.



INTERNET RESOURCES

http://www.youtube.com/watch?v=Xcsp0486oIY	What is Entrepreneurship?
http://www.youtube.com/watch?v=nlbPII-iTI	Introduction to Entrepreneurship

A-Z GLOSSARY

Entrepreneur	Self-employed person
Entrepreneurship	The process of setting up own business
Project formulation	It is the systematic development of a project idea for the eventual objective of arriving at an investment decision.
Motivating	Influence, initiate and make the person think and act accordingly.
Management	On entrepreneur stands for not only working of the venture but also managing of the day-to-day problems.
Innovation	Doing new things or doing of things that are already being done in a new way.
Entrepreneurship Development Programme (EDP)	Means inculcating entrepreneurial skills required for setting up and operating business enterprises.
Product	A set of tangible, intangible and associated attributes capable of being exchanged for a value with ability to satisfy consumer and business needs.
Accounting	It is an art of recording, classifying and summarizing in a significant manner.
Capital	The amount invested by the proprietor or owner of the business.
Assets	Anything that has economic value, a property belonging to the business including the amounts due to the business form other.

QUESTIONS AND ANSWERS

PART – I

Objective Questions

1. They are the driving forces behind a nation's economy.
 (a) Entrepreneur (b) Retailer
 (c) Manager (d) Agent.
2. This type of entrepreneur is timid and cautious.
 (a) Drove (b) Innovative
 (c) Adoptive (d) Fabian
3. It is the management philosophy and company practices that aim to utilise resources of an organization in effective way.
 (a) Total Quality Control
 (b) Quality Assurance
 (c) Statistical Quality Control
 (d) Control Charts
4. Multiple activities are carried out by this type of entrepreneur.
 (a) Women (b) Men
 (c) Rural (d) Urban.
5. Designing of course curriculum is done during this phase of training programme.
 (a) Training Phase
 (b) Pre-training Phase
 (c) Post-training Phase
 (d) Monitory Phase



PART – II

Answer in Three (Or) Four Points

1. Define entrepreneurship.
2. Differentiate entrepreneur and entrepreneurship.

3. What is a project?
4. Define Quality Control.
5. What is accounting?
6. Who is women entrepreneur?
7. Define entrepreneurial developmental programme.
8. What is SWOT analysis?

PART – III

Answer in a Paragraph

1. What are the qualities required for an entrepreneur?
2. Account for the motivational factors involved for women entrepreneur.
3. Write a detail note on Accounting and Book Keeping.
4. Give the benefit of Quality Control.
5. Enumerate on project management.
6. Brief on the motivational factors that influence the setting of enterprise by women entrepreneur.

PART – IV

Answer in One Page

1. List and explain various types of entrepreneurs.
2. Elaborate on project formulation.
3. Give a detail note on the steps involved in setting up small scale units.
4. Explain the need for entrepreneurial development programmes.

Answers for the Objective Questions

1 (a) 2 (d) 3 (a) 4 (a) 5 (b)

CHAPTER

14

Advertisement

LEARNING OBJECTIVES

- To learn about the importance of advertisement
- To know the different types of advertisements



their product in the market among the consumers within a very short duration. It is communicated through various media which includes traditional as well as modern. Advertisement is the apt tool to disseminate the importance and features of any product. It carries real time information with extraordinary emotional appeal.

14.1 Introduction

Advertisement has become an important segment in marketing. It is the most powerful and multi-dimensional tool to take products from the manufacturer to the consumers. Even the smallest object requires advertisement to escalate its sales and promotion.

The term advertisement is derived from a Latin word “Advertere”, which means “to turn the minds of people towards”. Advertisement is a marketing communication which involves openly sponsored, non-personal messages in order to sell or promote a product, idea or service in audio or visual form. It is the easiest and one of the most effective and efficient technique of communication which persuades the public to familiarise with a product. Advertisements are opted by business sectors who wish to promote

Definition

“Advertising is the non-personal communication from an identified sponsor using mass media to persuade or influence an audience”.

“Advertising is a paid form of non personal presentation of the facts about goods, services or ideas to a group. These facts are illustrated with the use of copy and art work that includes photographs and drawings”, defined by American Marketing Association.

14.2 Need of Advertisement

- **To Reach New Customers**

The market for a product changes constantly potential to attract new customers arise when a new family arise

in the society. The consumer's lifestyle, buying habits keep changing which gives the chance of new customers in every business.

- **Influence Shoppers throughout the Buying Cycle**

Advertisement reaches the consumers directly which curtails the time in comparing prices, quality and service and helps them to retain the purchase.

Advertisement is communicated through various mass media including traditional media as well as modern media.

- **It Pays off over a Long Period**

A good advertisement gives a long-term advantage over the competitors prevailing in the market. A study revealed that many companies who expanded advertising over five years escalated their sales in an average of 100 per cent.

- **To Generate More Store Traffic**

Constant traffic in the store is the first step to increase sales and to expand the product outreach.

- **To Keep a Healthy Positive Image**

It corrects the misleading opinions and gossip about a product and brings more shoppers.

14.3 Qualities of Good Advertisement

The major qualities required for good advertisement are

- **Ability to Communicate**

Since there is a large number of competitors in the market for any product, attractive advertisement

becomes popular among the consumers.

- **Good Strategy**

A good advertisement will always be strategically strong. It is planned in such a way to reach the targeted audience. A success of an advertisement is to check how well the goal has been achieved.

- **Great Creativity**

Imparting one's creativity in advertising is an integral part. An entire advertisement works on the imagination of a team. It is the central idea that sticks to the people's memory. Creative thinkers rule the field of advertisement and it maintains constant demand.

- **Clear Execution**

Having a plan to follow is an essential in advertisement. The craftsmanship of a good advertisement is seen by the way how it is executed. It shows the details, techniques and fine tuned values.

14.4 Classification of Advertisement

Advertisement is classified based on its functional aspect, type of trade and product life cycle. It may be classified as follows;

14.4.1 Institutional Advertising

It is done during the time of product shortages in order to maintain the name of the company or product before the public. It promotes the ideas, policies and sometimes potential issues of a company. It creates good will of the organisation. For Example : Siyarams advertisement for suiting and shirting.

14.4.2 Product Advertisement

It is designed in such a way to promote sales and reputation of a service or particular product. It may introduce a product, develop demand in the market. The product advertisement can be of private or government. For example, initially, the owner of Saravana store was appearing in the advertisement and after establishing the store, other celebrities are also seen.

14.4.3 Pioneering Advertisement

This is mainly used in the introductory stage of a product. First and foremost, it creates a primary demand and disseminates information regarding the product category rather than any particular brand. For example : The initial advertisement of jeggins when leggins was in peak.

14.4.4 Competitive Advertisement

This can be help where the product reaches the market maturity stage. At this point the product seeks selective demand. Focus is placed on the specific brand rather than general. Advertisement highlights the advantage and special feature of a particular brand comparing other. For example: Some garment brand offer lowest fares and high services for customers comparing others.

14.4.5 Retentive Advertisement

When a product achieves the top most position in the market, this can be done by the company. In this case the sponsor wants people to retain the brand name in public. An approach of soft selling is used. For example: Raymond suiting, though they have reached the pinnacle they still

retain their advertisement to remember their name.

14.3.6 Public Service or Non-Commercial Advertisement

They focus on the welfare of the society or a community or nation. The feedback of such advertisements can be seen in terms of good will they generate for the sponsoring organisation. For example : Swatch bharat campaigns are advertised in media to bring awareness among the people about cleanliness.

14.4.7 Trade or Business Advertisement

It is the form of commercial advertisement with respect to wholesale or retail stores. In wholesale it focuses on product promotion which will increase the suppliers. On retail the particular store is highlighted. For example : Pothys and Chennai Silks advertisements through both audio and visual media.

DO YOU KNOW? What is the expenditure of fashion industry per year?

With such a huge amount of money available, the big fashion retailers spend a ridiculous amount of money each year trying to get you to buy their wares. Annual spend on advertising for the industry stands at over \$500 Billion, and this figure is only likely to rise by 4.3 %. In the present year 557.99 billion dollars are spent so far.

14.4.8 Regional Advertising

It is the advertisement given according to particular geographical area. The business established in one geographical region publishes in that region only.

For example: Silk shops like PSR and Mahaveers advertisement in a particular region.

14.5 Types of Advertisement

Types of advertisement are explained depending upon the source in which it is approached.

14.5.1 Print Media

Newspaper or magazine can promote the business to the large customers. Readers tend to glance the advertisement as they read. It gets registered to the readers easily. To target specific audience, magazines can be used. For example: The designer clothing brands are published in fashion magazines which targets the socialites. The showroom and retail shop advertisements are published in newspaper.



Figure 14.1 Print Media

14.5.2 Radio /Audio Media

Radio is a great way to reach the larger audience. Advertising in the radio channel which is listening by wider audience is the direct way to reach the customers. For instance, the Adi sale for the clothing stores are announced repeatedly in the radio.



Figure 14.2 Radio (audio) Media

14.5.3 Television

Advertisement which needs an extensive reach can be done in television. It has the advantage of sound, sight, colour and movement which persuades the customers to use the product. Television advertisements are usually pervasive as the consumer's gets easily attracted to it. For example: The clothing store advertisement of Saravana Stores.

14.5.4 Outdoor or Bill Board Advertisement

Outdoor bill boards placed on the public buildings and hoardings placed on the highways make an impact as larger depiction can make better remembrance. When people pass by the bill board every day they are more likely to make business with the sponsors. For example: Designer store advertisement placed in highways.



Figure 14.3 Outdoor or Billboard Advertisement

14.5.5 Direct Mail, Catalogues and Leaflets

It reaches the customers directly in person. It is a more personal approach as the audience for whom the advertisement can be targeted. It is more cost effective and they can also save for revenue. For example: Pamphlets are saved by the consumers.

14.5.6 In store Advertisement

It takes place within the retail store. The retail brands advertise their new collections or products in the entrance of their shop. For example: Clothing store like Lifestyle, Reliance Trends exhibit their new range of collection in the store front.



Figure 14.4 Instore Advertisement

14.5.7 Online

It is the cost effective way to attract new customers in every way. Global audience can be reached in online advertising. As the advertisement pop on the screen is viewed by the consumers when they visit any web pages. For example, the pop-up advertisement of Voonik clothing in the websites.



Figure 14.5 Online



Do you know that the present trend in advertisements?

Facebook advertisements are inexpensive and have a high return in sales as it reaches the individuals directly. At the same time the company earns in billions. In 2015 it earned a profit of 3.69 billion through advertisements.

14.5.8 Word of Mouth Advertisement

It is a way of creditable promotion as the sponsors are not directly influenced and it is absolutely free of cost.



Figure 14.6 Word of mouth Advertisement

14.6 Preparation of an Advertisement

Beginning Stage

- The sponsor briefing the idea to the advertisement agency
- Internal discussion in the agency
- Conducting market research relevant to the advertisement regarding the competitors and target audience
- Selecting the media in which the advertisement to be executed
- Allotting the budget.



Development Stage

- Creating or filming the advertisement
- Designing in the way it has to be
- Reviewing the advertisement internally
- Making or producing the advertisement
- Testing the advertisement prior to publishing
- Getting the approval from the authority of agency
- Fixing the time and release of the advertisement.

Execution Stage

- Scheduling the media prior publishing and booking the media required to publish
- Presenting the advertisement in the selected media and make it active.

Post Execution

- Monitoring the release of advertisement
- Evaluating and judging the performance of the advertisement among the customers
- Making note of reviews from the customers
- Assessing the market response for the advertisement in terms of product selling.

14.7 Role of Advertisement

There are four main roles for advertisement;

- Marketing Role
- Communication Role
- Economic Role
- Societal Role

Marketing Role

Advertisement is a great platform to reach customers apart from sales promotion, personal selling and public relation. It is the most visible promotional program in any organisation.

The Communication Role

It is also a mass communication while transmitting different types of market information to buyers, it creates an image on the product.

The Economic Role

It helps the society to achieve abundance by persuading the customers with respect to the values and service of the products.

The Societal Role

It manifests the information about the product to the customers. It aids to compare various brands of same product.

14.8 Advantages and Disadvantages of Advertisement

The major advantages of advertisement are;

- **It increases Demand**
It attracts the customers and stimulates interest in them to buy the product.
- **It increases the Sales**
As the demand arises, the sale of the product increases.
- **Reduction in Cost and Prices**
As the demand increases the large-scale production is made, which will cut down the cost of the product.

- **Creates Particular Image**

A brand image among the consumer is created by the advertisement.

- **Economic Distribution**

The dealers, agents, middlemen distribute the goods and the product attains economic distribution.

- **Promotes Business through Competition**

It creates competitor among other brands and results in promotion.

- **Exploration of New Market**

It not only retains the existing customers but also grabs new clients towards them.

- **Helps in Rational Buying**

The quality of the product can be justified.

- **It Guides People**

It helps people to compare various other products.

Disadvantages of Advertisements

The major disadvantages of the advertisement are;

- **It increases Unnecessary Needs**

Sometimes people buy some unwanted products which they do not use but are merely influenced by advertisement.

- **It increases Cost**

The consumers always bear the expenditure as hidden changes of the product.

- **It misrepresents the Facts**

Sometimes the ideas featured in the advertisements are untruthful.

- **It results in Monopoly**

It acts as a threat to small scale manufacturer.

- **Wastage of Resources**

Human mind is proving to change and they are influenced by other products soon.

- **It spoils the Beauty**

Sometimes spoils the beauty of the city, towns and villages as too much is exposed.

- **Affects the Children**

Children are greatly influenced by the advertisements as they are more prominent wearers.

14.9 SUMMARY

Advertisements are an essential part in the market which increase the communication of ideas, services or products through newspapers, magazines, TV, posters, online and radio, resulting in purchase of the product. When it comes to apparel industry, a considerable portion in our society has certain fashion wants and needs that remain unknown by the buyer, therefore advertising helps in creating awareness of the product and its uses. Advertising has become the integral and inevitable part which satisfies these clothing needs. Thus, it should be planned and executed carefully and more efficiently to be most effective among consumers. Because the approachable group of consumers look forward to advertisements which they watch and get attracted and decide upon their clothing choices.

POINTS TO REMEMBER

- Advertisement is the most effective form of communication which reaches the consumers directly.
- Advertisements can be done in different Medias.
- Different products approach different types of advertisements.

ACTIVITIES FOR TEACHER

- The teacher can show video to the students on how different types of Advertisement has been done.
- Students can prepare an assignment on the different types of Advertisement.
- Collect and show the different types of advertisements.
- Conduct a debate among students of two groups regarding the advantages and disadvantages of advertisement

ACTIVITIES FOR STUDENTS

- Plan and prepare for an advertisement of any clothing brand
- Collect some forms of print advertisement.



INTERNET RESOURCES

https://www.youtube.com/watch?v=zUGm6PiLMUE	How to Create an Effective Advertising Plan
https://www.youtube.com/watch?v=Wzge-AQ1v2w	The Best Digital Advertising Trends of 2018
https://www.youtube.com/watch?v=FscwPHMQpIw-	Best Advertising Ideas for Small Business

A-Z GLOSSARY

Persuade	Induce (someone) to do something through reasoning or argument.
Consumers	The <i>consumer</i> is the one who pays something to consume goods and services produced.
Escalate	Increase rapidly
Advertisement	A notice or announcement in a public medium promoting a product, service, or event
Pinnacle	The most successful point
Sponsor	A person or organization that pays for or contributes to the costs
Manifest	Clear or obvious to the eye or mind.
Abundance	A very large quantity of something.
Middle men	A person who buys goods from producers and sells them to retailers or consumers.
Grab	Grasp or seize suddenly and roughly

QUESTIONS AND ANSWERS

PART – I

Objective Questions

1. The term *advertere* means _____.
 - a) to bring of
 - b) to turn towards the mind
 - c) to convince
 - d) to manipulate
2. The term advertisement is derived from a _____.
 - a) Latin word
 - b) Greek word
 - c) Sanskrit word
 - d) English word
3. Regional advertising is focused on _____.
 - a) Particular geographical area
 - b) Particular group of people
 - c) Particular age of people
 - d) None
4. Which form of advertisement does not require any money?
 - a) Online
 - b) Television
 - c) Mails
 - d) Word of mouth
5. This is a great way to reach the larger audience.
 - a) Mails
 - b) Radio
 - c) Online
 - d) Television



PART – II

Answer in Three (Or) Four Points

1. Define advertisement.
2. What does an audio medium do?
3. List out the work done in execution stage.
4. Give two disadvantages of advertisement.
5. What are the qualities of good advertisement?

PART – III

Answer in a Paragraph

1. Explain the steps involved in preparing an advertisement.
2. What are the merits and demerits of advertisement?

PART – IV

Answer in One Page

1. Write down the classification of advertisement with suitable examples.
2. Elucidate the different types of advertisement.

Answers for Objective Questions

1. (b) 2. (a) 3. (a) 4.(d) 5.(b)

Role of Computer in Garment Industry



LEARNING OBJECTIVES

- To learn about the use of CAD and CAM in garment sector
- To gain knowledge about various textile and fashion softwares

15.1 Introduction

Computers have influenced every sphere of human life. Life has become easier and comfortable with the use of computer. In the field of garment industry, computers help to design, analyse and manufacture the product within a short span of time. The first step of garment production is designing. The designers do hand sketches, or drape fabric in a dress form. CAD software has begun to make inroads into the world of fashion and textile industry, enable mass customization, develop more designs, and facilitate to make frequent changes in styles and production. Computer Aided designing software not only provides the possibility to speed up the process of putting a new model into production and improve the

quality of the products, but also reduces material costs and labour intensity.

Definition

Computer Aided Design (CAD) in fashion industry helps to create sketches, prototypes and designs of garments. CAD is essentially an automated system for the design, drafting, display of graphically oriented information and also used in the manufacturing process for layouts. It makes the work easier through efficient use of softwares.

15.2 Types of Cad System

The apparel industry has started using size designation systems, garment style, design, and colour combination to produce and sell ready-to-wear clothing. There are different types of CAD systems available in the market for the use of garment industry are as follows;

Digitizing systems

- Grading systems
- Sketching sheet
- Simulation and texture

- Design modification
- Marker Making Systems(MMS)
- Pattern Design Software (PDS)
- Pattern Generation Software (PGS)
- Body Measurement Software (BMS)
- Texture Mapping
- Embroidery systems
- Specification and costing systems

15.3 Application of Cad in Textile And Garment Designing

The fashion business is growing rapidly and brings great opportunities and challenges to textile and clothing enterprises. Apparel industries follow the trend of the international market and latest technologies for industrial up gradation. Many textile and fashion designers use CAD systems for creating textile and garment designing. The designer may start by hand-drawing a few rough images. Then, the rough images are scanned into a computer and final designing is done using CAD.

A designer uses CAD to modify design drafts and make changes. Depending on the type of textile designing, a designer use different types of CAD software. There are systems for designing as well as creating knitted, printed fabrics, illustration and sketch pad applications that allow a person to draw freehand directly on the computer. There are CAD systems that show a designer how a fabric might drape for a particular style of garment. Some CAD programs even design embroidery patterns.

CAD finds its practical utility in textile, apparel and fashion industry right from design initiation and production

stage through lay planning, spreading, pattern making, cutting and finally sewing. Two-dimensional pattern design software's based on flat patternmaking techniques have been successfully explored for patternmaking, grading, and creating pattern libraries within software for future retrieval.

However, a further progress made in the field is three-dimensional (3D) software. It works in virtual environment permitting 3D visualization of drape and fit on virtual model or avatar. This method eliminates exhaustive process of physical sample generation. 3D scanning, mapping, customized avatars in accordance with specific anthropometric and facial features, customized garments are some of the innovative and exciting avenues available with CAD software packages. Enhanced productivity, competitiveness, and shorter delivery schedules can be guaranteed by linking design, manufacturing operations along with other preproduction steps of patternmaking, grading, and marking.

DO YOU KNOW? Why Enterprise Resource Planning (ERP) Software in Textile and Apparel Industry?

It is software that collects information from all sections of the enterprise, assists in planning and implementation of various functions relating to all departments



15.4 Cad Hardware and Software

Computer hardware and software can be described as follows;

● Hardware

Computer hardware includes types of equipment such as the monitor, hard-drive, keyboard and mouse. Peripherals are added to the hardware to perform specific functions. Examples; Plotters, digitizing tables or printers.

● Operating Systems

An operating system is a vehicle through which the hardware can read the software programmes. These operating systems are used in an organization with software programmes. Certain software programmes can only work on specific operating systems. Examples; Windows, Linux or Mac.

● Software

Software programmes are written to perform different tasks. For example, Microsoft Office is usually used, for writing documents. Other software programmes, such as Corel Draw, are used to create or modify graphics images. Generic software programmes can be used in lot of disciplines. Corel Draw can be applied for design in Graphic Design as well as Fashion Design. For example, Stork is a software programme written exclusively for use in design.

15.4.1 Uses of Computer Aided Design (CAD) in Different Sector

Computer aided design software or CAD software is vastly used in some major sectors of today's technological areas;

- Fashion design sector
- Apparel sector
- AEC i.e. Architecture Engineering and Construction sector
- ECAD i.e. Electronic and electrical sector
- MCAD i.e. Mechanical sector:
 - Aerospace
 - Automotive
 - Machinery
 - Consumer Goods
 - Ship Building

15.4.2 Different areas of Textiles where CAD systems are used

Textile designing is a technical process which includes different methods of textile production. It includes both surface design and structural design of a textile. The textile designer must have knowledge of yarn making, weaving, knitting, dyeing, finishing processes and also knowledge about different types of looms, knitting machines and printing processes.

Following are the types of software developed for various textiles weave design;

- Design Dobby
- Adobe Illustrator
- C-Design Fashion
- Vetigraph
- Corel DRAW

- Fashion CAD
- Inventor
- Weave It
- iWeave It
- Grid 'N Weave It

15.4.3 Types of Textile and Fashion CAD Software's

I. 2D CAD softwares available in the clothing industry are;

- GRAFIS from Software Dr. K. Fridrich
- Audaces Apparel Pattern from Audaces
- COAT from COAT-EDV System
- PAD Pattern design from PAD System Technologies Inc.
- TUKACAD from Tukatech
- CAD Assyst from Assyst
- Fashion CAD from CAD CAM Solutions
- Modaris from Lectra
- Accumark from Gerber Technology.

II 3D CAD software for the clothing industry are

- Modaris 3D Fit from Lectra
- Virtual fashion from Reyes Infografica
- Vidya from Assyst-Bullmer
- AccumarkVstitcher from Gerber
- 3D Runway from Optitex
- Haute Covture 3D from PAD System
- Design concept from Lectra
- Vstitcher from Browzwear
- EFit Simulator from Tukatech.

III Classification of 3D CAD System Used in Apparel Industry

- Combined Techniques
- 3D modelling and 2D pattern unwrapping

- Digital draping
- 3D simulation of 2D patterns
- 2D sketch-based 3D simulation
- Reactive 2D/3D design technique.

The textile and apparel industry comprises a complex network of interrelated sectors that produce fibres and yarns, fabricate cloth, finishing, dyeing, printing and apparel manufacturing. Computer technology is one of the most important tools contributing to the significant advancement of this industry.

15.5 Types of Cad Systems

- Textile design systems
- Knitted fabrics
- Printed fabrics
- Illustrations/ Sketch Pad Systems
- Texture Mapping: 3D Draping Software
- Embroidery systems
- Textile Design Systems



Textile design is the process of developing designs for woven, knitted or printed fabrics or surface ornamented

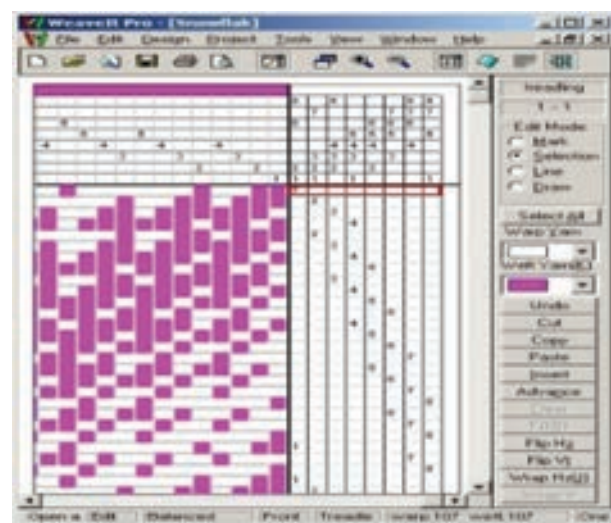
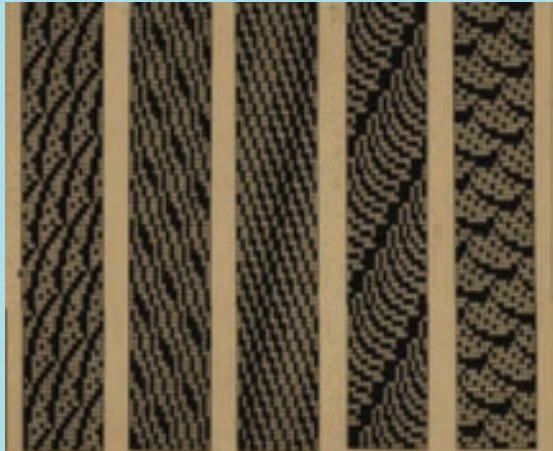

Figure 15.1 Textile Design System

fabrics. Textile designers are involved with the production of these designs. The designs developed are then used on Textiles and clothing materials.

Do YOU KNOW? What is weave Library?

Weave library create any weave structure virtually. Predetermined weave designs are stored in weave library. New weave patterns can be created and stored. One or more number of weave structures can be combined in one inch fabric



● Knitted Fabrics

The specialized CAD software is also available for knitwear design. Indication of all knit stitch formation can be viewed on the screen. CAD program produces a pullover graph and it specifies the information on amount of yarn needed by colour for each piece.

The other example of the new technology in the industries is using a yarn scanner. It is attached to the computer and it scans a thousand meters of yarn and then simulates a knitted fabric on-screen. This simulation shows how the fabric will look when knitted using the selected yarn.



Figure 15.2 Knit Fabric Pattern

● Illustrations/ Sketch Pad Systems

Sketchpad is an innovative computer program. It has graphic programmes that allow the designer to use pen or stylus on electronic pad or tablet. Freehand images can be created and then stored in the computer. Using this sketchpad, a lot of different knit and weave simulations can also be created and stored in a library. Later the stored designs can be selected and pasted over the sketches to show texture and dimensions.

● Texture Mapping : 3D Draping Software

Texture mapping is a graphic design process which shows the visual effects of fabric on the body. In this system, the fabric can be draped over a form in a realistic way. The designer starts with an image of a model wearing a garment. Each section of the garment is outlined from seam line to seam line. The swatch of a new fabric is created in the textile design system and laid over the area. The computer automatically fills in the area with new colour.

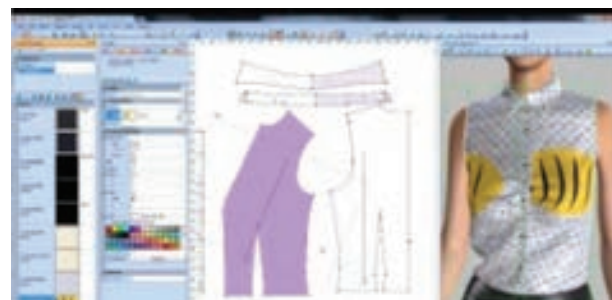

Figure 15.3 Texture Mapping Software

● Embroidery Systems

The embroidery design software is used for mass producing the home and commercial embroidered textiles. The designs used for embroidery can be incorporated on the fabric for making garment. Designers can create embroidery designs or motifs straight on the computer. Colour of the design and embroidery stitches is defined. Several combinations of colour and stitches are possible in this system.



Figure 15.4 Embroidery System

● Digitizing Systems

Digitizing is a process of adding details to an original pattern or sloper in the computer. The pattern can be prepared by marking the notches, by defining the series of selected points around the pattern. These basic patterns can be manipulated with the help of specific tools in the computer. For example in case of trousers, darts can be moved and pleats can be created, also new designs can be created on screen from pre-existing pattern.

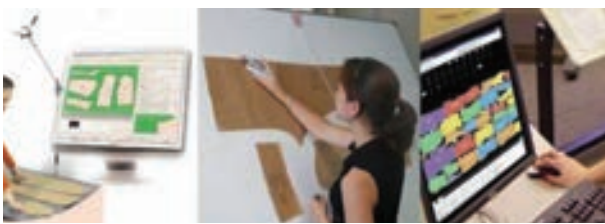

Figure 15.5 Digitizing Software

● Grading Systems

Pattern grading is the process of turning base size or sample size patterns into additional sizes using a size specification sheet or grading. It is simply increasing or decreasing the size of patterns. Production sample meant for approval is normally medium size but if the buyer requires different size then the patterns are graded to Small(S), Large (L), Extra Large (XL), Double Extra Large (XXL).

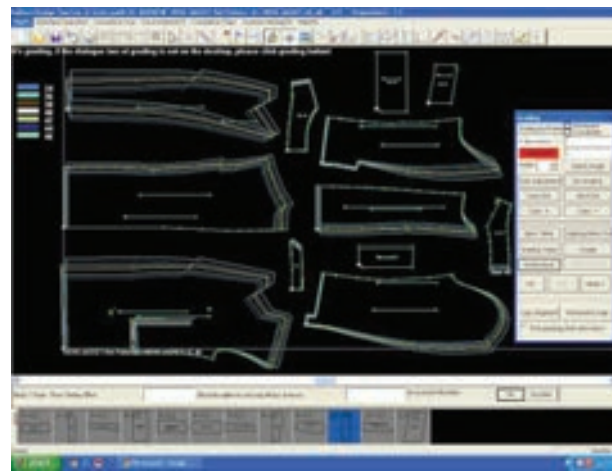

Figure 15.6 Grading System

● Marker Making Systems

A marker is commonly done on large thin paper. It holds all the size of pattern pieces for a specific style of garments. Computerized method is the best and



Figure 15.7 Marker Making System

most popular method of marker making which makes the efficient marker. This method ensures minimum wastage of fabric. On plain fabric marker making is relatively simple but on striped fabric, matching of fabric requires utmost care. The Computer Aided marker making system is considered to be an easier way for preparing markers.

15.6 Advantages of Cad

Increasingly, CAD and CAM are considered as standard system used in the textile industry. These systems provide many advantages to textile designers and textile manufacturers. They are as follows;

- CAD allows the designer to be more creative
- Using CAD software, designers can create new sketches more quickly and precisely
- More accurate patterns with less chance of mistakes can be created
- Design can be digitally transferred directly into a CAM system
- It allows designers to graphically test ideas in real time without creating real prototypes
- Redrawing and Resizing of a garment can be done quickly
- CAD systems consumes less time
- CAD and CAM software's are being operated efficiently with expansion of the graphic memory allocation
- Every sector of the fashion industry from haute couture to the mass market has felt the impact of CAD
- CAD has become increasingly important that it has helped to secure a job in fashion design
- Designers can easily adapt a single design to varying materials and patterns, and build upon and also can alter existing designs to create new pieces
- CAD cuts down the cost by letting designers view virtual versions of finished products without the need of purchasing materials
- Designers can view the designs in both 2D and 3D using CAD and can make alterations immediately
- The designers can view the entire design history of their product
- CAD allows fashion designers to work smarter, and shortens the time taken between the initial concepts to the finished product.

15.7 Recent Development in Cad Industry

Modern computer-aided designing software provides the possibility to avoid small operations and manual work, to raise precision, productivity and organize information flow. Computer Aided garment designing system excludes the time consuming manual preparation of patterns, creation of layouts and also relocation of written information. The computer systems execute every single process and the integration of all processes into one joint flow, for the organization of logistics and the mobility of work tasks. The computerization of different processes in the garment industry is necessary to reduce the costs of a product and to raise the competitiveness.

Computerized designing systems use software specifically designed for the development of industry specific objects, input and output of graphics, scanners and other remote devices. Computer systems allow making two-dimensional and three-dimensional product illustrations and visualizations. It is possible to create computer-aided garment patterns, gradations, and a virtual pattern. Such computer-aided operations significantly save time and costs necessary to design a product. The cost of a product can be calculated with the help of the product management systems of the company stored in a database.

Recently, a variety of CAD systems have been widely used in the field of fashion. The software system like Lectra gives a comparative concentration on the integration of CAD software. The system has adopted new strategies to expand its technology and provide a system of simulation for the entire textile industry from yarn and textile design; manufacture of virtual goods and to the ready-to-wear since 1998. It represents the direction of development of a new generation of textile and clothing in computer aided design.

Assyst Bullmer system can simulate three-dimensional effect which can give the design structure and fabric. It also has more than 400 different kinds of databases for optional format-making, picturizing and modifying. It can make a format automatically and according to the actual size, it can change the size freely. The system also has intelligent database, which can make styles quick and efficient. Spanish Investronica system has made more effective efforts in the application of artificial intelligence and other technologies.

15.8 SUMMARY

Computers play a major role in the Apparel Industry. Right from designing to manufacture of garments, specialised CAD and CAM systems are utilised. Newer designs can be created and stored for future use also. Mass production of textile and apparel goods require CAD and CAM systems to reduce the lead time for delivery of goods. In the era of globalisation, there is a great competition for the apparel manufactures to deliver goods in international standards. Use of advanced CAD and CAM systems is the smartest way and the industries could cater to the huge demand of textiles and apparel goods.

POINTS TO REMEMBER

- In the field of garment industry, computers help to design, analyse and manufacture the product within a short span of time.
- CAD software has begun to make inroads into the world of fashion and textile industry, enable mass customization, develop more designs, and facilitate to make frequent changes in style and production.
- The apparel industry has started using size designation systems, garment style, design, and colour combination to produce and sell ready-to-wear clothing.

- The fashion industry is growing rapidly and brings great opportunities and challenges to textile and clothing enterprises.
- CAD finds its practical utility in textile, apparel and fashion industry right from design initiation and production stage through lay planning, spreading, pattern making, cutting and finally sewing.
- Computer hardware includes types of equipment such as the monitor, hard-drive, keyboard and mouse.
- An operating system is a vehicle through which the hardware can read the software programmes.
- Textile designing is a technical process including different methods for production of textile.
- The textile and apparel industry comprises a complex network of interrelated sectors that produce fibres, spin yarns, fabricate cloth, and dye/finish/print and manufacture apparel.
- Sketch Pad has graphic programmes that allow the designer to use pen or stylus on electronic pad or tablet.
- The embroidery design software is used for mass producing the home and commercial embroidered textiles.
- CAD and CAM are considered as standard system used in the textile industry.

ACTIVITIES FOR TEACHER

- Can show how the CAD Software is been used.
- Can show how the different types of CAD systems work

ACTIVITIES FOR STUDENTS

- Can learn how the CAD software is used in the Textile Industry.
- Can do embroidery using the Embroidery Design Software



INTERNET RESOURCES

https://www.youtube.com/watch?v=-2ygIZak6BE	CAD software for Students: Learn assembly modeling techniques with Solid Edge
https://www.youtube.com/watch?v=MaRkMhazpUI	Choosing 3d printing CAD software

A-Z
GLOSSARY

Computer Aided Design	Helps to create sketches, prototypes and designs of garments.
operating system	It is a vehicle through which the hardware can read the software programmes.
Textile design	The process of developing designs for woven, knitted or printed fabrics or surface ornamented fabrics
Sketchpad	Graphic programmes that allow the designer to use pen or stylus on electronic pad or tablet.
Texture mapping	A graphic design process which shows the visual effects of the fabric on the body. In this system, the fabric can be draped over a form in a realistic way
Pattern grading	The process of turning base size or sample size patterns into additional sizes using a size specification sheet or grading.

QUESTIONS AND ANSWERS

PART – I

Objective Questions

1. CAD is a _____ tool that enables you to make quick and accurate drawings with the use of a computer.
 - a) Electronic
 - b) Current
 - c) Software
 - d) Hardware
2. This can be used for design in graphic design as well as fashion design.
 - a) Photoshop
 - b) CAD
 - c) Corel draw
 - d) None of the above
3. The points at which the pattern has to be increased are _____
 - a) Growth points
 - b) Edges
 - c) Side points
 - d) Bottom line
4. Pattern designing software is wide spread in _____
 - a) Germany
 - b) Italy
 - c) India
 - d) Both A and B
5. The data can be easily stored, transmitted and transported through
 - a) Hardware files
 - b) Software files
 - c) Computer files
 - d) Both A and B
6. This can be done by defining the X, Y co-ordinates of series of selected prints around the pattern.
 - a) Digitizing Systems
 - b) Embroidery Systems
 - c) Sketch Pad Systems
 - d) None of the above



PART – II**Answer in Three (Or) Four Points**

1. Define CAD.
2. Explain Grading System.
3. List the areas of Textiles where the CAD systems are mostly used.
4. Mention the application of Corel draw.

PART – III**Answer in a Paragraph**

1. What are CAD Hardware and Software?
2. Explain the use of Pattern Making Software.
3. Write short note on Corel draw.
4. State the types of fashion CAD.
5. Discuss on the Hardware and Software used in Apparel Industry.

PART – IV**Answer in One Page**

1. Account for the CAD system used in different areas of textiles and Fashion sector.
2. Enumerate the application of designing software.
3. Present the recent developments in Textile and Fashion CAD.

Answers for Objective Questions

1. (c) 2.(c) 3.(a) 4. (d) 5.(c) 6.(a)

CASE STUDY 1

P. Dhanapriya

Research Scholar

Annai Sivagami Government
Girls Higher Secondary School,
Puducherry.

I joined Textiles and Dress Designing course under vocational group in my 11th & 12th std during the year 2009-2011 at **Annai Sivagami Government Girls Higher Secondary School**. In my plus two education I learned about different types of stitching, embroidery, pattern making and designing dress. The course increased my interest towards creating new varieties of fabrics to cater to different draping styles.

I joined B.Sc. Costumes Design and Fashion Technology course after completing 12th standard during the year 2011-2014. The UG program helped me to know more about costume designing and fabric formation, which enabled me to design my own dress, my relatives and friends in a very fashionable way. However to create unique costumes the regular fabrics in the market did not serve the purpose. Therefore I pursued my higher studies in M.Sc. Bio Textiles at Avinashilingam Institute for Home Science and Higher Education for women (Deemed to be University). This course facilitated me to create eco friendly fabrics which could be used for medical textiles apart from dress designing. The knowledge gained motivated me to continue my higher studies. Presently I am doing my Ph.D to gain more knowledge about the natural dyes and their application to create ayurvedic fabrics. Now I am able to pursue my passion which gives me self-satisfaction. I am sure my research will enable me to create newer fabrics. My life has got its real meaning and purpose only due to the initial encouragement and motivation given by my excellent school and teachers.

CASE STUDY 2

Pratiksha. N Parhar

Merchandiser

CSI Bain Matriculation Higher Secondary
School, Kilpauk

It was in my 5th grade I realized a spark in me for fashion designing, trust me I was too young for that! Then when it was time for me to choose my further course after 10th boards, what better can I choose apart from Textiles and Dress Designing course in 11 & 12 grade! Being in Chennai I selected **CSI Bain Matriculation Higher Secondary School, Kilpauk** for my +2 education. It was my first step towards my dreams. Those two years helped me to lay a strong foundation in theoretical or practical knowledge for textile as well as fashion. It was a great learning! And also how can I forget the values taught by my teachers!

After which I joined International Institute of Fashion Designing (INIFD) and completed B.Sc in Fashion designing. Those three years were extremely amazing in terms of knowledge, as well as in terms of opportunities! I was part of many workshops and fashion shows. It gave me an opportunity to work with skilled people and designers. One such event was the Lakmé Fashion Week, in the year 2015, wherein my garment was selected for display. During the final year I also got an opportunity to do six months internship with designer Sonal Daga which helped me to gain practical knowledge, communication and management skills. In the final year I was awarded the best out going student! Well this was just the start of my career. After my higher education I choose the area of retailing to work with. I was selected as an intern in Zara through INIFD. I even got an opportunity to work in H&M as a visual merchandiser. I was able to learn about trend, outfits, styling and also the commercial aspect of a branding.

I further have plans to start my own Brand by keeping one thing in my mind that “Every day is a new learning and opportunity”.

CASE STUDY 3

K. Revathi **Entrepreneur**

CGHSS, MH Road,
Chennai.

I joined Textile and Dress Designing, vocational course in my higher secondary education from 2002 to 2004 at **CGHSS, Chennai**. I found the course to be very interesting therefore I wanted to improve my skills in the same area. Therefore I joined an industrial school certificate course on needle work, dress making and embroidery. Later I started a tailoring shop and employed two persons to assist me. The secret behind running this shop successfully was my vocational training at school.

My dream is to become a tailoring teacher as I was inspired by my teacher at school. Due to family circumstances I was unable to pursue my goal. However my dream made me to join Technical teacher certificate course after ten years in 2015-2016. Now I have registered my certificate in Social Welfare Board. Through it I got orders to stitch school uniforms in bulk orders. This has given me ultimate joy and job satisfaction. I am able to pursue my passion and take care of my family simultaneously. My life has got its real meaning and purpose only due to the initial encouragement and motivation given by my wonderful school and excellent teachers.

CASE STUDY 4

M.Mareeswari

Designer

Nirmala Girl's Higher Secondary School,
Madurai

Being interested in garment designing I selected Textile and Dress Designing, vocational course as the subject to be learnt in my higher secondary course in 2013 in **Nirmala Girl's Higher Secondary School, Madurai**. This course helped me to acquire skills in designing and sewing on one hand and also gave me clear cut knowledge about different type of fabrics and their applications in the dress making. The course also added the concept of looking upon the irregularities of figures and means of giving a face lift to their looks through designing suitable dresses.

After my 11th and 12th, I took up B.Sc Costume Design and Fashion in Standard Fireworks Rajaratnam *College for Women*, Sivakasi. I noticed my fellow mates struggling to get the work done whereas I could go about doing it without much hassle due to the strong foundation laid during my higher secondary education. It is very important in designing that the foundation is set right and strong to know step by step procedures to go about making a garment. All practical and theoretical knowledge gain from my higher secondary course helped me to come across all battles in college and all thanks to my teachers in school.

At present I am working as manager in a Shree Designer Boutique from last 3 years with full of satisfaction. In future my goal is to shine as a fashion designer and working hard for that.

CASE STUDY 5

S. Manjula Craft Teacher

Nirmala Girls Higher
secondary school, Madurai.

I studied the Vocational program Textiles and Dress Designing in my higher secondary at **Nirmala Girl's Higher Secondary School, Madurai**, during the year 1986-1988. Due to financial crises and family back ground I was unable to continue my higher studies. My curiosity in designing increased and my school teachers encouraged me in doing embroidery works during my school days. My interest in embroidery gave a turning point in my life.

With the support of my family and by the Gods grace, I have joined in Maharishi Vidhyala school as craft teacher. My strong foundation in dress designing and embroidery has enhanced my skills in imparting this knowledge especially to the young minds of my school who can become the future designers. I am very happy that I have chosen this course and I am thankful to my teachers and the school who laid the foundation of my development.



CASE STUDY 6

M. Maheswari

Teacher

T.E.L.C Girls Higher Secondary school,
Uslampatti, Madurai

Due to my in born interest in designing clothes, I took up Textile And Dress Designing as my Higher Secondary course at **T.E.L.C Girls Higher Secondary School, Uslampatti**, Madurai District during 1994-1996. I got high score in +2 therefore my parents advised me to study B.A Tamil. Later I completed M.A Tamil.

Then I got seat in B.Ed Tamil and realised that college is a place where you basically have to be independent, with more of self study and assignments to build your skill and gain knowledge. In B.Ed I was really glad that I was a step ahead from the rest due to my practical knowledge and skill from dress designing course. I noticed my class mates struggling to complete their practical work whereas I could finish it without much burden due to the strong foundation laid during my higher secondary education in 'Dress Designing'. At present I am happily working in school where I have studied.



CASE STUDY 7

T. Kasuthuri

Teacher

T.E.L.C Girls Higher Secondary
school, Uslampatti, Madurai

After my 10th boards in 1996, my parents wanted me to take up science and become a professional since I got high score in science. I had to fight battles to go against and take up Textiles and Dress Designing at **T.E.L.C Girls Higher Secondary School, Uslampatti, Madurai** district because that's what I wanted to do. After that I have completed Diploma in Teacher Certificate Course. With the Gods grace and the knowledge got from my school teachers, I have joined as a teacher in the same school where I studied. Presently I am working with full of satisfaction.

I am very grateful to my school and staff members who encouraged me and helped me to develop myself.

Model Question Paper

Textiles and Dress Designing - Theory

STANDARD XII

MARKS: 90

PART- A

Circle the correct answers

1 x 15 = 15

- _____ is a process that alters the surface of the fabric by providing a three dimensional or raised effect on selected areas.
(a) **Embossing** (b) Singeing (c) Shearing (d) Napping
- Dyes that react with the fibres and form covalent bonds are called as
(a) Embossing (b) Singeing (c) Shearing (d) **Reactive dyes**
- The rotary screen printing produces more than _____ yards of fabric per hour
(a) **3500** (b) 2500 (c) 4000 (d) 4200
- The _____ family is the traditional type of family structure
(a) Extended Family (b) Single Parent Family
(c) Blended Family (d) **Nuclear Family**
- The toddler needs clothing that provides maximum freedom for all the activities usual at _____ stage
(a) **1-2 years** (b) 5-11 years (c) 12-15 years (d) 15-20
- The word _____ means one part in relation to another
(a) **Proportion** (b) Balance (c) Rhythm (d) Harmony
- Interlacing of warp and weft yarns at right angle direction are called as
(a) Knitting (b) **Weaving** (c) Non woven (d) Leather
- _____ fabric is very thin, slippery and delicate
(a) Cotton (b) Wool (c) **Silk** (d) Polyester
- _____ is an embroidery technique that is probably thousands of years old
(a) **Smocking** (b) Appliqué (c) Embroidery (d) Sequence

10. Denim is a _____ weight fabric with very little drape or stretch
(a) Low (b) Medium (c) **Heavy** (d) None of the above
11. Apparel industry concentrates on three major methods of garment making namely home-made, tailor made and _____.
(a) Concept store (b) Boutique (c) **Ready-made** (d) Custom made
12. _____ includes the time calculation and scheduling of the order, the lead time
(a) Programming (b) **Planning** (c) Samples (d) Inspection
13. The analysis made for external and internal environment together is called
(a) Quality (b) TQM (c) Quality Control (d) **SWOT**
14. Advertisement which needs an extensive reach can be done in
a) News paper (b) Radio (c) **Television** (d) Online
15. _____ is a process of adding details to an original pattern or sloper in the computer
(a) **Digitizing Systems** (b) Embroidery Systems
(c) Sketch Pad Systems (d) None of the above

PART- B

Answer any 10 question in short (21-compulsory question)

10 x 3 = 30

16. List the temporary finishes.
17. Write a note on classification of natural dyes.
18. List out any three difference between Dyeing and printing.
19. Define extended family
20. Write the principles of washing.
21. What is structural design?
22. Define on grain.
23. List the types of layouts\.
24. Name the motifs kasuti embroidery.
25. Expand SWOT and TQM
26. Give two advantages of advertisement.

27. What is ready made garment?

28. Who is a merchandiser?

PART- C

Answer any 5 question in short (35- Compulsory question)

5 x 5 = 25

29. Write a note on fabric dyeing.

30. Give a short note on methods of dyeing.

31. Explain the types of family.

32. Brief note on starching and its types.

33. Discuss about the smocking.

34. What are the Steps involved in construction of shirt?

35. Write a detailed note on kashmiri embroidery.

PART- D

Answer all the question with internal choose

2 x 10 = 20

36. Enumerate on functional finishes.

(or)

36. Write detailed note on elements of design with reference to dress designing. Highlight your answer with suitable figures.

37. Give the modifications for pattern alteration of front bodice block in case of very big and very small bust Highlight your answer with suitable figures.

(or)

37. Explain in detail the role of computer in textiles and dress designing.

REFERENCE BOOKS

1. Helen Joseph (2013), "Pattern Making for Fashion Design", Peason Educations, New Delhi.
2. Jaffe (2012), "Draping Fashion Design", Sonali Publication, New Delhi.
3. Suzanne Marshal (2012), "Individuality in Clothing Selection and Personal Appearance", Pearson Prentice Hal.
4. Pete Barry (2016), "The Advertising Concept Book", Thames & Hudson.
5. Philip Kotlar and Kevin lane (2006), "Marketing Management", Keller Pearson Education, Inc, Delhi.
6. Ellen Diamond (2006), "Fashion Retailing", A Multi-Channel Approach – Second Edition, Pearson Education, Delhi.
7. Mike Easey, (2005), "Fashion Marketing" – Second Edition, Black Well Publishing, Australia.
8. Khanaka, S.S. (2006), "Entrepreneurial Development", S. Chand and Company Ltd., New Delhi.
9. Singh A.K. (2009), "Entrepreneurship Development and Management". Lakshmi publications pvt. Ltd. New Delhi.
10. Jinlian Hu (2011), "Computer Technology for Textiles and Apparel, Woodhead" Publishing Series in Textiles.
11. Calvin Wong (2017), "Applications of Computer Vision in Fashion and Textiles", The Textile Institute Book Series.
12. Arora. A (2011), "Textbook of Dyes", Sonali Publications, New Delhi.
13. Kapoor Seema (2012), "Dyeing of Textile material", Sonali Publication, New Delhi
14. Clarke, W. (2004), "An Introduction to Textile Printing", Wood Head Publishing Limited, London.
15. Krishnakumar, M. (2010), "Apparel Merchandising" An integrated approach, Abhishek Publications, Chandigrah.,
16. Vasugi Raaja, N. (2011), "Apparel Merchandising Management", Pranav Publications, Tamilnadu.
17. Sangeeta Sharma, Raghuvir Singh (2009), "Advertisement Planning and Implementation", PHL Learning Private Limited, New Delhi.
18. Brooklyn Hers and Barbara J. Phillips, "Exploring Advertising Equity in Fashion Advertising", Vol. 39, 2018, pp. 192-205.
19. Deepali Rastogi and Sheetal Chopra (2017), "Textile Science", Orient Blackswan Private Limited, Hyderebad, .
20. Seema Sekhri (2016), "Text book of Fabric Science", PHI Learning Private Limited, Delhi.



TEXTILES AND DRESS DESIGNING

Practical



Textiles and Dress Designing Practical

Exercise No.	Chapter Title	Page No.	Month
1	Gathered Frock with Puff Sleeve	247	June
2	In Skirt	250	June
3	Cut Choli	253	July
4	T-Shirt	257	July-Aug
5	Salwar	261	Aug-Sept
6	Kameez	264	September
7	Pyjama	268	October
8	Kalidhar Kurta	271	November
	Project	274	November
	Field Trip	275	December
	Model Question Paper - Practicals	276	December

Gathered Frock with Puff Sleeve

PRACTICAL

01

LEARNING OBJECTIVES

- To develop knowledge in stitching gathered frock with puff sleeve
- To learn the selection of fabric and decorative items used for stitching gathered frock with puff sleeve

Introduction

- Frock with puff sleeve is used for children.
- It can be modified with introduction of yokes, collars and variation in sleeves.

Tools required

Measuring Tools	-	Measuring Tape, Scale.
Drawing Tools	-	Brown Paper, Bell Pin, Table, Pencil.
Marking Tools	-	Tailor's Chalk, Pencil.
Cutting Tools	-	Scissors, Seam Rippers, Fabric Cutting Shears.
Stitching Tools	-	Thread, Hand Needle, Stitching Machine.
Ironing Tools	-	Iron Board, Iron Box.
Fasteners Tools	-	Hook, Press Button.
Decorating Items	-	Applique, Embroidery.

Suitable Materials

Poplin, Printed cotton fabric, Silk and Fancy varieties of synthetic fabric.

Material Requirements

If the width is 90 cms, 150 cm of fabric is needed.

Measurements

AGE	-	3 years
Frock Length	-	56 cm
Chest Circumference	-	60 cm
Shoulder Width	-	24 cm
Bodice Length	-	24 cm
Skirt Length	-	32 cm
Sleeve Length	-	12 cm
Sleeve Circumference	-	16 cm

Drafting

Bodice part (Front & Back)

AB = CD	-	Bodice Length (24 cm)
AC = BD	-	1/4 Chest circumference (15 cm)
A - F	-	Back neck (3 cm)
A - G	-	Front neck (6 cm)
A - E	-	Neck width(6 cm)
E - H	-	1/4 Shoulder width (6 cm)
H - I	-	(12 cm)
J - D	-	(1.5 cm)

Skirt part

AB = CD	-	Skirt Length (32cm)
AC = BD	-	Skirt Width(50 cm)
S - G	-	Straight grain

Sleeve part

AB = CD	-	Sleeve length (12 cm)
AC = BD	-	Half of Upper Sleeve Circumference (16 cm)
C - E	-	1/2 AC (or) BD
F - D	-	1 cm

Cutting lines

Front Bodice Part	-	G, E, H, I, J, B
Back Bodice Part	-	F, E, H, I, J, B

Skirt	-	A, C, D, B
Sleeve	-	A, E, F, B

Garment components

Front Piece	-	1
Back Part	-	2
Skirt (Front and Back)	-	2
Sleeve	-	2

Layout

The fabric is folded in lengthwise centre fold.

Marking and cutting

- Mark the cutting lines on the fabric along with seam allowance.

Stitching Method

- Attach the front and back bodice.
- Placket should be stitched on the back bodice.
- Sew darts in the required position on the front and back bodice pattern.
- Puff should be stitched on the upper part of the sleeve and attach it with the armhole.
- Finish the neckline with piping.
- Skirt part is stitched with the bodice part introducing required pleats or gathered
- Finish the side seam of frock with french seam.
- Finish the raw edges of skirt with hemming.

Finishing

- Stitch the hook and eyes.
- Trim all the extra threads.
- Fold and iron the frock.

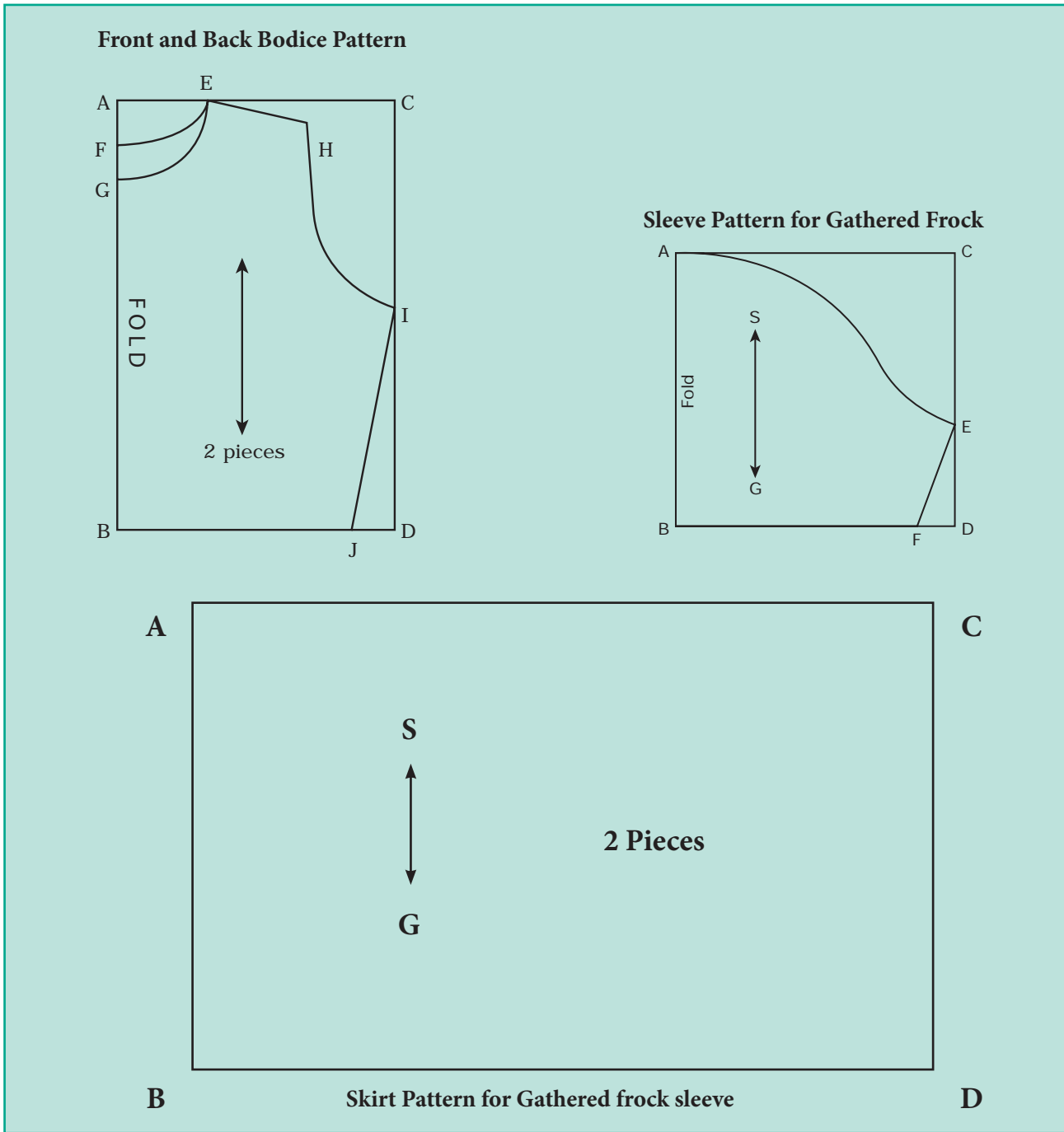

Types of Gathered Frock

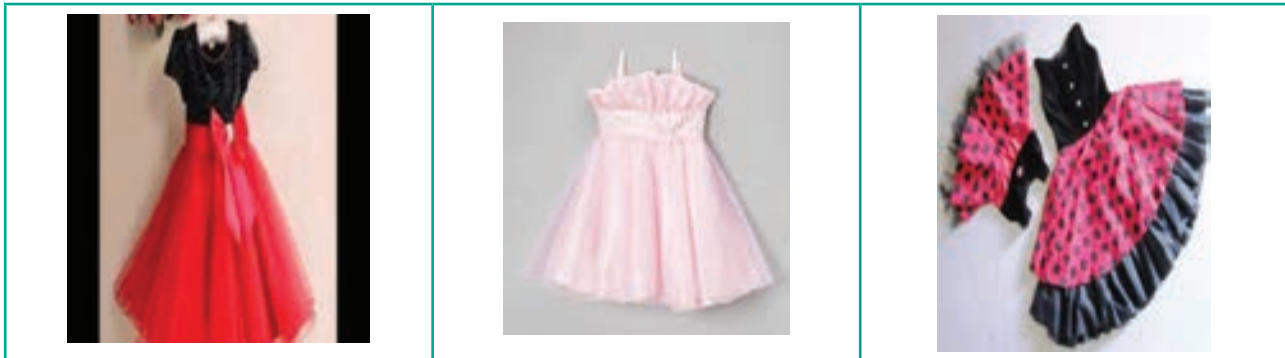

Frock with Gathered Skirt

Frock with Short Yoke

Frock with Gathered Frills

Inskirt

PRACTICAL

02

LEARNING OBJECTIVES

- Sewing skills in stitching inskirts.
- Gaining knowledge in selecting material and accessories for the construction of inskirts.

● Introduction

- This is an important inner garment for Women.
- It is used as an inner wear for sarees and skirts.
- It can be stitched by 2, 4, 6 panels also.

Tools Required

Measuring Tools	-	Inch Tape, Scale.
Drawing Tools	-	Brown Paper, Bell Pin, Pencil, Table.
Marking Tools	-	Tailor's Chalk, Pencil.
Cutting Tools	-	Scissors, Seam Rippers, Fabric Shears.
Stitching Tools	-	Thread, Hand Needle, Sewing Machine.
Ironing Tools	-	Iron Table, Iron Box.
Fastening Attachments	-	Elastic Band, Cord.
Decorative Materials	-	Frills, Piping, Scalloped Edges, Embroidery.

Fabric Required

2 meters

Suitable Fabrics

Organic Cotton, Poplin Cloth.

Measurement

Age	-	16 years
Waist	-	88 cm
Full Skirt Length	-	95 cm
Full Skirt Length - Band	-	$95 - 8 = 87$ cm

Note

Cut 10 cm of cloth from 90 cm of the cloth for waist band. **After cutting**, fold the cloth of 80 cm into half as 40 cm.

Drafting

Inskirt

Draw ABCD as rectangle,

AB = CD - Length (87 cm)

AC = BD - 40 cm

AE = DF - $\frac{1}{8}$ Waist Length + 2 cm
Extra Allowance (13 cm)

Join E and F

Mark 1 1/2 cm from AE and DF and draw curve line as shown in the figure.

Cutting lines

A, E, F

Layout

The fabric is folded in combination fold

Marking and cutting

After marking, cut the cloth with seam allowance

Garment components

Centre Piece	-	2
Side Piece	-	4
Waist Band	-	1

Stitching Method

- Join the side panels with centre panel piece on both sides respectively.
- Join front and back piece together.
- Leave sufficient space for the waist band opening at one side and join the seams.
- Join waist band.
- Hem the bottom and finish the inskirt.

Finishing

- Insert the cord in the waist band.
- Cut the unwanted waste threads.
- Iron the stitched garment for folding.

Inskirt pattern

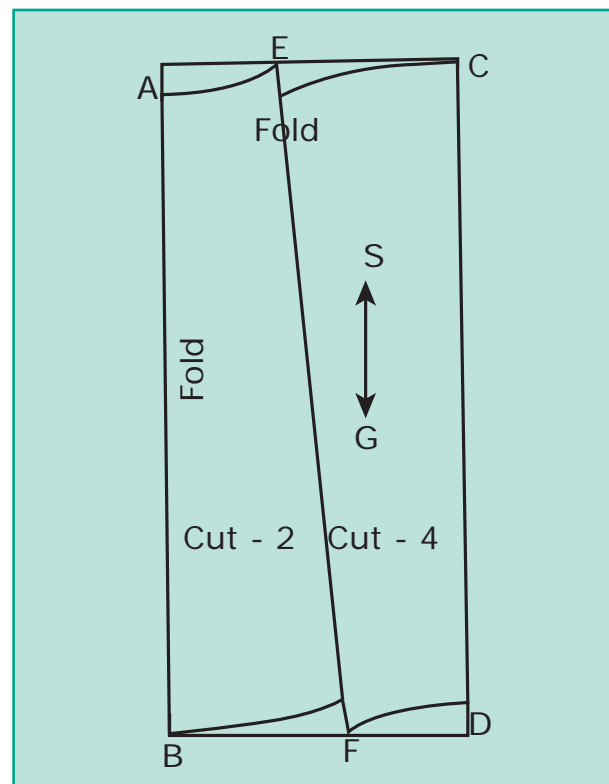



Types of Inskirt



Four Gore Inskirt

Six Gore Inskirt

Gathered Inskirt



Cut Choli

PRACTICAL

03

LEARNING OBJECTIVES

- To gain the knowledge in stitching cut choli.
- To learn the selection of fabric and types of decorative items to be incorporated in cut choli.

Introduction

- The garment is usually worn by Women.
- It is worn along with saree and half saree.
- It is a tight fitting garment worn according to body size.

Tools required

Measuring Tools	-	Measuring Tape, Scale.
Drawing Tools	-	Brown Paper, Bell Pin, Table, Pencil.
Marking Tools	-	Tailor's Chalk, Pencil.
Cutting Tools	-	Scissors, Seam Rippers, Fabric Shears.
Stitching Tools	-	Thread, Hand Needle, Sewing Machine.
Pressing Tools	-	Ironing Board, Ironing Box.
Fasteners Attachments	-	Press Button, Hook and Eyes.
Decoratives	-	Applique, Embroidery, Lace, Border Design, Stone Work, Jammiki Works

Suitable Fabrics

Voils, Cotton, Silk, Velvet, Huckobha Printed Silk, Umber, 2 x 2 Blouse Materials. These types of fabrics can be used.

Measurements

Age	-	15 Years
Full Length	-	35 cm + 4 cm (for Hem)
Bust Circumference	-	75 cm
Shoulder Width	-	32 cm
Hip Circumference	-	62 cm
Arm (Sleeve) Circumference	-	28 cm
Sleeve Length	-	20 cm

Fabric requirement

Height of garment + twice the length of the sleeve + 5 cm of the fabric is needed (90 cm).

DRAFTING

Front bodice

AB = CD	-	Full Length
AJ = CK	-	Full Length – Cross Belt (8 cm)
AC = BD	-	1/4 of Bust Circumference (19 cm) +5 cm=24 cm
AE	-	Front Neck Depth (10 cm)
A – E	-	Neck Width (7.5 cm)
AG	-	1/2 the Shoulder Width (16 cm)
GH	-	1/6 of Bust Circumferences (14 cm + 2 1/2 cm)
DI	-	2.5 cm
JB – KD	-	Waist Band
HKD	-	Side Seam
E F G H K J E	-	Front Bodice Pattern
SG	-	Straight Grain

Back bodice

A B = C D	-	Full Length + 4 cm
A C = B D	-	1/4 of Bust Circumference (19 cm) + 2 cm=21 cm
A E	-	Back Neck (10 cm)
A F	-	Neck Width (7.5 cm)
A G	-	1/2 the Shoulder Width (16 cm)
G H	-	1/6 of Bust Circumferences + 2.5 cm (14 cm + 2.5 cm)
D I	-	2.5 cm
H I	-	Side Seam
S G	-	Straight Grain
E F G H I B E	-	Back Bodice Pattern

Drafting sleeve:

A B = C D	-	Sleeve Length (20 cm)
B D = AC	-	Sleeve Width (14 cm)
A E	-	Sleeve Armhole
C E	-	7 cm
E F	-	Side Seam
B F	-	Sleeve Hem Line

Cutting lines:

Front Side	-	E F G H K J
Cross Belt	-	J K D B
Back Side	-	E F G H I B
Sleeve	-	A E F B

Layout

The fabric is folded in lengthwise centre fold.

Marking and cutting

Cut according to the pattern which is placed in the fabric after including seam allowances.

Garment components

Front Bodice - 2 Pieces

Cross Band - 4 Pieces

Back Bodice - 1 piece

Sleeve - 2 pieces

Fabric required for finishing neck and plackets.

Stitching methods

- On the front bodice make three darts and join the cross band along with it.
- On the front bodice, attach the plackets.
- On the back bodice, make two half darts.
- Finish the edges of the sleeve and join the side seams.
- Join the sleeve patterns along with the bodice patterns.
- By using the cross piece finish the edges of the necklines.

Finishing

- Cut off the unwanted threads.
- Stitch hook and eyes at the required areas.
- Finished garments should be ironed neatly.

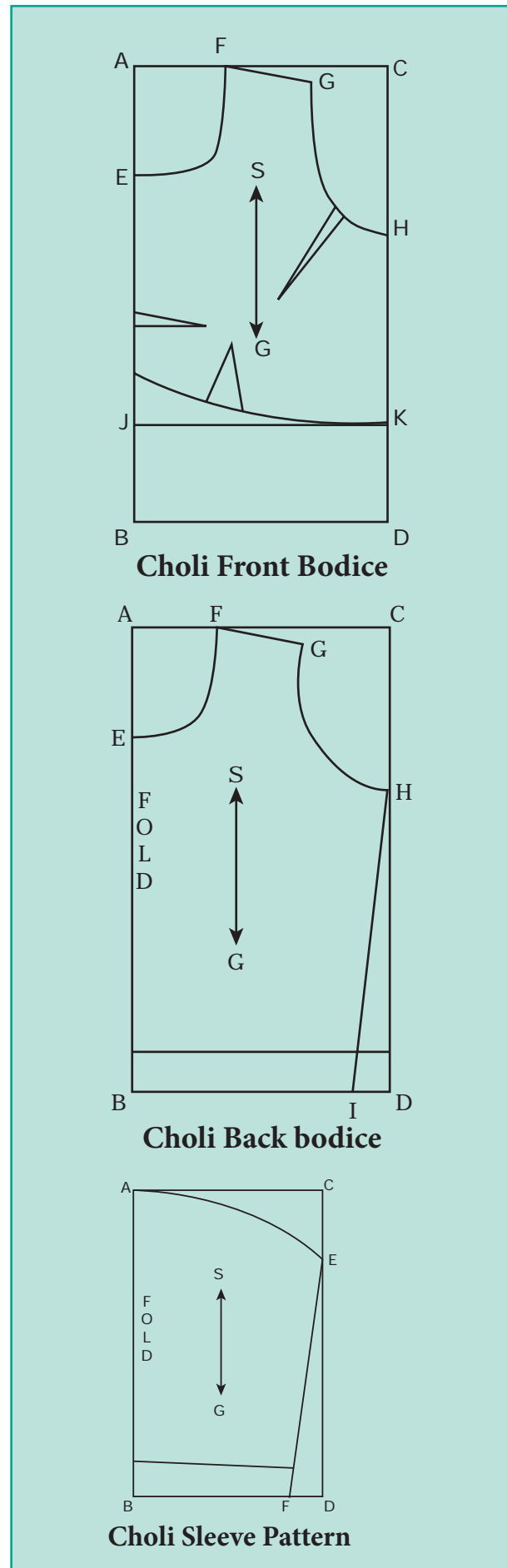



Types of Cut Choli



Round Neck Cut Choli



Cut Choli with Fancy back bodice and sleeve



Fancy Neck Line Back Open Cut Choli



Netted Fancy Cut Choli



T-Shirt

PRACTICAL

04

LEARNING OBJECTIVES

- To increase the skills in stitching a T-Shirt.
- To know about what kind of fabric should be selected and the ways of stitching a T-Shirt.

Introduction

- T-Shirt is worn by all men irrespective of their age.
- Today T-Shirt is used by women also.
- Yoke can be attached on the back side of T-Shirts to add interests.
- Collar can be attached along with the neck line.

Tools required

Measuring Tools	- Measuring Tape, Scale.
Drawing Tools	- Brown Paper, Bell Pin, Table, Pencil.
Marking Tools	- Tailor's Chalk, Marking Wheel.
Cutting Tools	- Scissors, Seam Rippers, Shears.
Stitching Tools	- Thread, Hand Needle, Sewing Machine.
Ironing Tools	- Ironing Board, Iron Box.
Fasteners Attachments	- Buttons, Button Holes.

Suitable materials

Cotton, Polyester, Terry Cotton, Spun.

Material used for stitching

1 meter

Measurements

Age	-	5 Years
Chest Circumference	-	65 cm
Length	-	45 cm
Shoulder Width	-	26 cm
Arm Scye	-	26 cm
Sleeve Length	-	13 cm + 2 cm (Seam allowance)

Drafting procedure

Front

AB = CD	-	Rectangle
AC = BD	-	1/4 Chest Circumference (16 cm) + 3 cm (for ease)
AB = CD	-	Length (45 cm) + Hem allowance (4 cm)
$A_1 - A = B_1 - B$	-	Front Opening (3 cm)
AE	-	Front Neck Depth (5 cm)
AF	-	Neck Width (5 cm)
AG	-	1/2 Shoulder Width (13 cm)
GH	-	1/2 Upper Arm Circumference (13 cm)
HD	-	Side Seam
SG	-	Straight Grain

Back bodice

AB = CD	-	Length (45 cm) + Hem Allowance (4 cm)
AC = BD	-	1/4 Chest Circumference (16 cm) + 3 cm (for ease)
AE	-	Back Neck Width (4 cm)

AF	-	Neck Width (5 cm)
AG	-	1/2 Shoulder Width (13 cm)
GH	-	1/2 Upper Arm Circumference (13 cm)
HD	-	Side Seam
SG	-	Straight Grain

Drafting procedure for sleeve

AB = CD	-	Sleeve Length + Hem (13 cm + 3 cm)
AC = BD	-	1/2 Upper Arm Circumference (13 cm)
CE	-	5 cm
DF	-	2 cm
BF	-	Sleeve Hem
EF	-	Side Seam

Drafting procedure for collar

AB = CD	-	Collar Height (8 cm)
AC = BD	-	Collar Width (16 cm)
DF	-	1.5 cm
AE	-	1 cm

Drafting procedure for pocket

AB = CD	-	Height (12 cm)
AC = BD	-	Width (10 cm)

Cutting lines

Front Bodices	-	$A_1 E F G H D B_1$
Back Bodice	-	E F G H D B
Sleeve	-	A E F B
Collar	-	E C F B

Layout

- Cut the shirt front bodice pattern such that the selvages are in the center front as plackets.

- Cut the shirt back bodices pattern on lengthwise grain such that the center back line is on fold.
- Cut the sleeve pattern on length wise grain with enough material for hem allowances.
- Cut the collar on the cross wise grain with the center on fold.

Marking and cutting

- Place the paper patterns on the fabric and cut with enough allowances.

Garment components

Shirt Front	-	2 Pieces
Shirt Back	-	1 Piece
Sleeve	-	2 Pieces
Collar	-	2 Pieces

Stitching Method

- Attach the front and back bodice along with the shoulder line.
- Sew the pocket on the left side of the front bodice pattern.
- Join the side seams
- Hem the sleeves and join the side seams.
- The sleeve should be attached to the bodice part in its arm hole.
- Join the two collar on all sides except the neck line.
- Turn it to the right side and make a row of stitches.
- Join the collar to the neck line.

Finishing

- Along the opening fix the button and button hole.
- Cut the unwanted hanging threads.
- Iron and fold the finished garment.

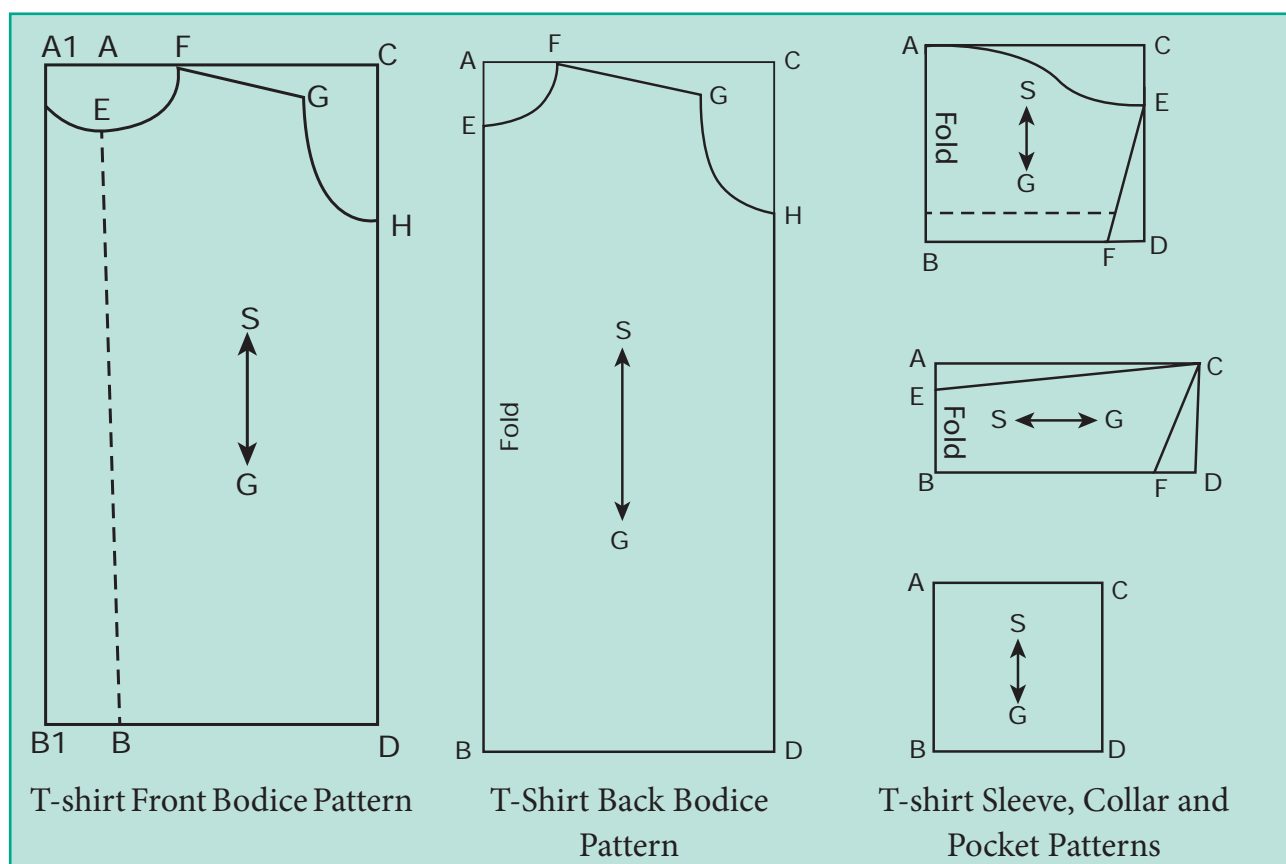



Types of T-Shirt



T-Shirt with Shirt Collar



T-Shirt with Round Collar



T-Shirt with Coloured Collar



T-Shirt with Deep Round Collar



Salwar

PRACTICAL

05

LEARNING OBJECTIVES

- To develop skills in sewing the salwar.
- To learn the different methods of constructing salwars.

Introduction

Salwar is worn by Indian women since early days. Today salwars are designed in various styles to suit the current trend and culture. Trousers, pants and pleated pants are mostly preferred for the pants. Waist bands are attached on the waist line with gatherings / elastic for the comfort of the wearers. Waist band are added both for functional and decorative purposes.

Tools required

Measuring Tools	-	Measuring Tape, Scale.
Drawing Tools	-	Brown Sheet, Bell Pin, Table, Pencil.
Marking Tools	-	Tailor's Chalk, Pencil.
Cutting Tools	-	Scissors, Seam Rippers, Fabric Shears.
Stitching Tools	-	Thread, Hand Needle, Sewing Machine.
Ironing Tools	-	Ironing Table, Iron Box.
Fasteners Attachments	-	Cords / Tapes.
Decorating Items	-	Collar Canvas.

Suitable materials

Cotton Fabric, Poplin, Fancy Materials, Floral Designed Cloths.

Measurements

Length	-	100 cm
Seat Circumference	-	90 cm
Bottom Circumference	-	45 cm

Required fabric

2 meters – 2 1/2 meter.

Drafting method

AD= BC= Full length

AB= 1/4 Seat Circumference + 15 cm

AE = 1/3 Seat + 3 cm

CF = 1/2 Bottom Circumference

AG = 5 cm

BK = 15 cm

BL = 1/4 Seat Circumference + 5 cm

Cutting lines

Waist Band - BLK

Leg Pattern - KEFC

Layout

Fabric should be folded on lengthwise centre fold for cutting.

Marking and cutting

Place the pattern on the fabric and leave sufficient fabric for seam allowance and cut.

Garment components

Band Piece - 1

Leg Piece - 2

Stitching method

- Join the side seams of the salwar.
- Gather the bottom of the salwar at the hem line to suit the leg circumference or according to the style.
- Finish the bottom with a binding.
- In case gathers are not introduced in the style then finish the hem line of the salwar with a facing. A suitable canvas piece can be place in between the facing for stiffness.
- Make a 2 or 3 rows of stitches for decoratio at the bottom of the salwar.
- At the front part of waist line, leave a suitable hole for opening and fold and machine.
- The hole must be finished with button hole stitches.
- Insert a cord into the waist band.

Finishing

- Remove unwanted threads.
- Insert cord into the waist band, iron the stitched garment and fold neatly.

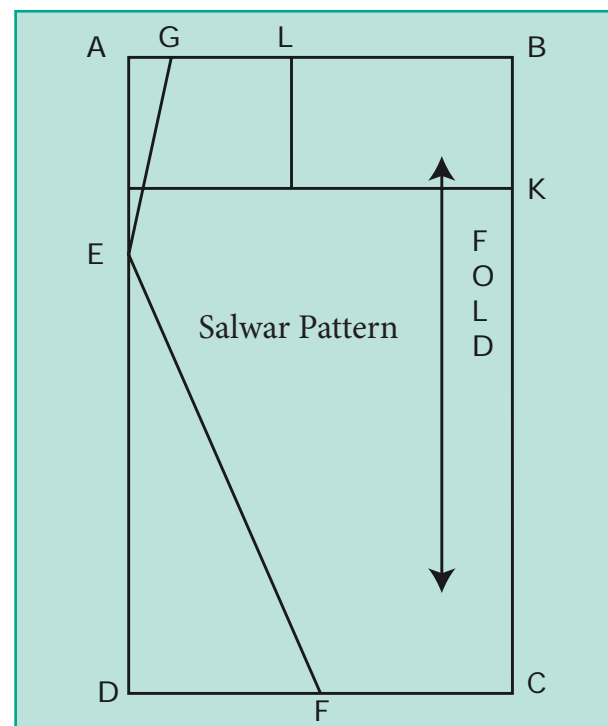



Salwar images



Salwar with Top Yoke



Salwar with Pleats

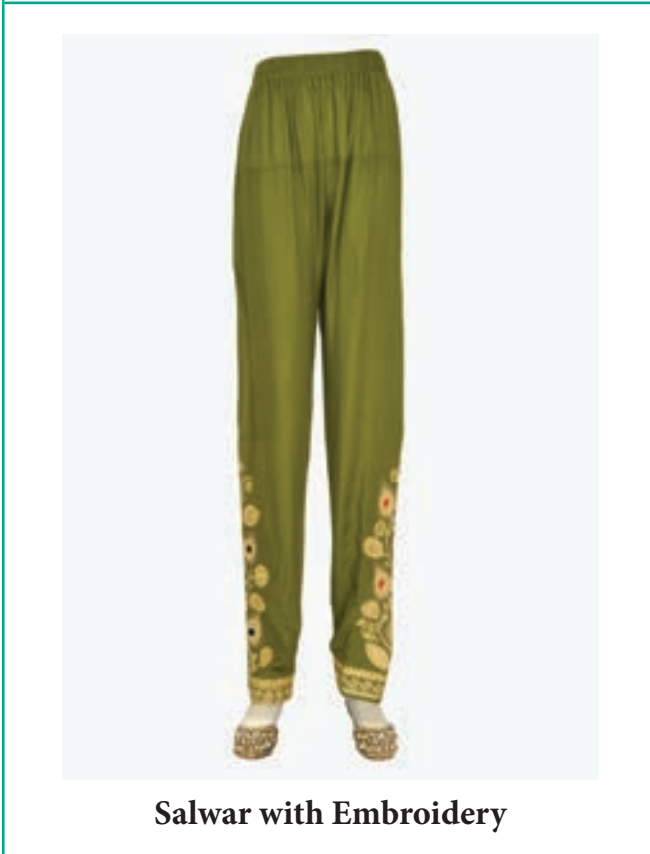

Salwar with Embroidery



Salwar in Dhoti Style



Kameez

PRACTICAL

06

LEARNING OBJECTIVES

- To improve the skill in stitching a kameez.
- To learn to select fabrics, decorations suitable for stitching a kameez.

Introduction

- Kameez is worn among Indian women since ages.
- It gives comfort to the wearer.
- It is a long and loose fitting garment.

Tools required

Measuring Tools	-	Inch Tape, Scale.
Drawing Tools	-	Brown Sheet, Bell Pin, Table, Pencil.
Marking Tools	-	Tailor's Chalk, Pencil.
Cutting Tools	-	Scissors, Seam Rippers, Fabric Shears.
Stitching Tools	-	Hand Needle, Thread, Sewing Machine.
Ironing Tools	-	Iron Table, Iron Box.
Fasteners Attachments	-	Hook and Eye, Press Button.
Decorating Materials	-	Applique, Embroidery, Lace, Sequence work.

Suitable fabrics

Muslin, Cotton, all types of silk fabrics and fancy fabrics.

Measurements

Length of Kameez	-	76 cm
Bust Circumference	-	80 cm
Upper Arm Circumference	-	35 cm
Shoulder Width	-	30 cm
Hip Circumference	-	75 cm
Sleeve Length	-	20 cm (with Hem Allowance)

Required fabric

Twice the length of kameez and sleeve length.

Drafting procedure

ABCD	-	Draw a rectangle
AB = CD	-	Length of Kameez + Hem Allowance (2 cm)
AC = BD	-	1/4 Bust Circumference + 4 cm
AC ₁	-	Front Neck Depth (8 cm)
AE	-	Neck Width (7 cm)
AG	-	1/2 Shoulder Width (15 cm)
GH	-	1/2 Upper Arm Circumference (17.5 cm)
HI	-	1/4 Bust Circumference (20 cm)
IJ	-	1 cm
DD ₁	-	10 cm
HJ L	-	Side Seam
AE	-	Back Neck Depth (6 cm)
F ₁ E G H J L D B F	-	Front and Back Patterns
SG	-	Straight Grain

Sleeve

AB = CD	-	Length of Sleeve
AC = BD	-	1/2 Upper arm Circumference
BF	-	Sleeve Hem Line
DF	-	1 cm
E – F	-	Side Seam
A – E	-	Arm Hole

Cutting lines

Kameez Front	-	C ₁ E G H J L D B
Kameez Back	-	F E G H J L D B
Sleeve	-	A E F B

Layout

Fold the fabric in lengthwise fold.

Garment components

Front Bodice	-	1
Back Bodice	-	1
Sleeve	-	2

Marking and cutting

Mark the pattern on the fabric, leave the seam allowance and cut.

Stitching Method

- With the help of the pattern cut the fabric.
- Join the shoulders of front and back patterns.
- Stitch the dart that is required in both front and back part of the kameez.
- Use continuous placket and finish the opening, as per the length needed.
- Finish the sleeve hem line and join it in the arm scye part of kameez.
- Join the side seams using French seam.
- Using bias piece finish the neck with a facing.

Finishing

- Stitch hook and eye at the closures.
- Cut unnecessary threads.
- Iron the kameez and fold it neatly.

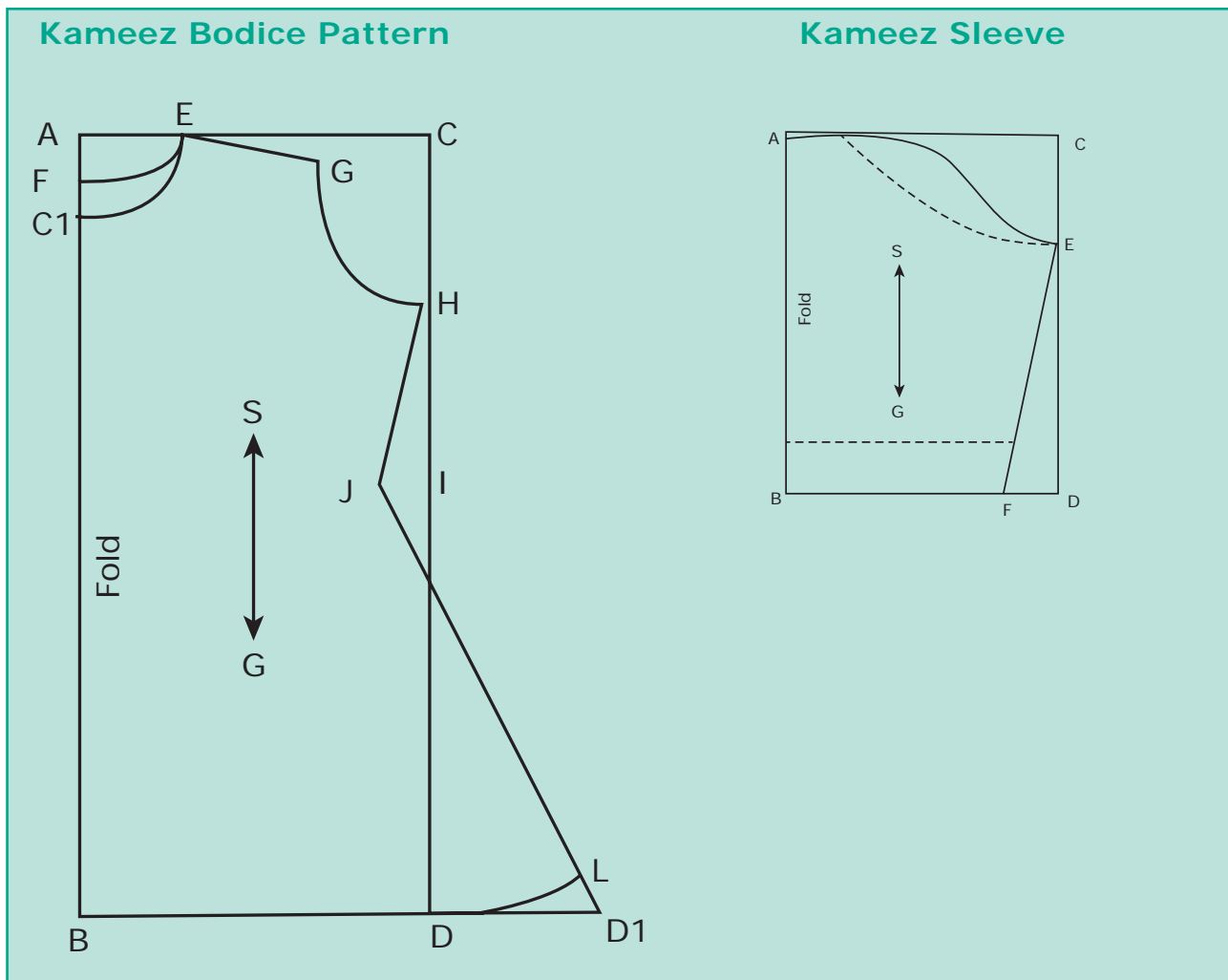



Kameez Images



Kameez with Heavy Embroidery



Kameez with Round Neck line



Kameez with V Neckline



Kameez with Patiala Style Salwar



Pyjama

PRACTICAL

07

LEARNING OBJECTIVES

- To know and gain knowledge on the construction of a pyjama.
- To understand the suitable fabric and designs for a pyjama.

Introduction

- Pyjama is adopted by all the age group of men as a lower garment.
- Pyjama serves as both casual and night wear garment.
- This is the traditional costume of Andhra Pradesh.

Tools required

Measuring Tools	- Measuring Tape, Scale.
Drawing Tools	- Brown Paper, Pins, Pencil, Drawing Table.
Marking Tools	- Tailor's Chalk, Pencil.
Cutting Tools	- Scissors, Seam Rippers, Fabric Shears.
Stitching Tools	- Thread, Hand Needle, Sewing Machine.
Ironing Tools	- Iron Box, Ironing Table.
Fasteners and Openers Attachments	- Elastic, Tape.
Decorating Items	- Embroidery, Applique Binding by using Contrast Fabric.

Suitable fabric

Cotton, Voils, Kathar.



Pyjama images



Night wear Pyjama

Kids wear Pyjama



Kalidhar Kurta

PRACTICAL

08

LEARNING OBJECTIVES

- To enrich the knowledge in stitching procedure of a kalidhar kurta.
- To select the suitable fabric, design and embellishments that can be added to the kalidhar kurta.

Introduction

- Kalidhar kurta was generally worn by north Indian men.
- Today the garments is also being adopted by the South Indian men as a festive and functional wear.

Tools Required

Measuring Tools	-	Measuring Tape, Scale.
Drawing Tools	-	Brown Sheets, Pins, Table, Pencil.
Marking Tools	-	Tailor's Chalk, Pencil.
Cutting Tools	-	Scissors, Seam Rippers, Shears.
Stitching Tools	-	Thread, Machine Needle, Hand Needle.
Ironing Tools	-	Iron Box, Iron Table.
Fasteners Attachments	-	Zipper, Button, Press Button.
Decorative Materials	-	Embroidery.

Suitable Fabric

Cotton, Silk, Polyester, Linen and other soft material can be used.

Measurements

Age	- 4 to 5 Years
Length	- 48 cm
Bust or Chest Circumference	- 65 cm
Sleeve Length	- 38 cm
Upper arm Circumference	- 26 cm
Shoulder Width	- 26 cm
Gusset Length / Width	- 8 cm / 8 cm
Khali (Side Piece)	- 4 cm
Upper Width	- 4 cm
Khali Lower Width	- 4 cm

Fabric requirement

Twice the length of the garment + sleeve length and extra 20 cm for finishing (1.50 mtrs.).

Drafting procedure

Construct a rectangle ABCD

AB = CD - Height + Hem allowances
(48 + 2) 50 cm

AE - Neck Width (8 cm)

AF - Back Neck Depth (4 cm)

AG - Front Neck Depth (8 cm)

AC - 1/2 of the Back Width
(Shoulder) (13 cm)

CH - 1/2 Upper Arm
Circumference (13 cm)

Side Panel or Khali pattern

$A_1 B_1 = C_1 D_1$ - Khali Height - 35 cm

$A_1 C_1$ - Upper Khali - 4 cm

$B_1 D_1$ - Lower Khali - 8 cm

Drafting procedure for sleeve

AB - Sleeve Length + 3 cm

AC - 1/2 the Upper Arm Circumference
(13 cm)

BE - 2 cm

AE - Sleeve Side Seam

ED - Sleeve Hem Line

Cutting lines

F E G E C D B - Kurta Front and Back

A B C D - Khali Piece

A B C D E - Sleeve

Layout

Fold the fabric in the length wise grain.

Marking and cutting

Using the paper pattern, mark the places to be cut on the fabric and cut the fabric by leaving enough of allowances for seams.

Garment components

Kurta Front and Back - 1 Piece

Khali Side Panel - 4 Pieces

Gusset - 2 Pieces

Sleeve - 2 Pieces

Stitching Procedure

- Attach the sleeve to the bodice.
- Join the khali piece to side seams of the bodice front, back and sleeves.
- Join the Gusset to the body and sleeve piece pattern.
- Make a mitre opening in the kurta.
- Finish the neck using bias piece.
- Stitch and finish the sleeve bottom and kurta bottom.
- Join the sides of the garment.

Finishing

- Trim out the unwanted threads.
- Finish out the openings with buttons.
- Iron and fold the finished garment.

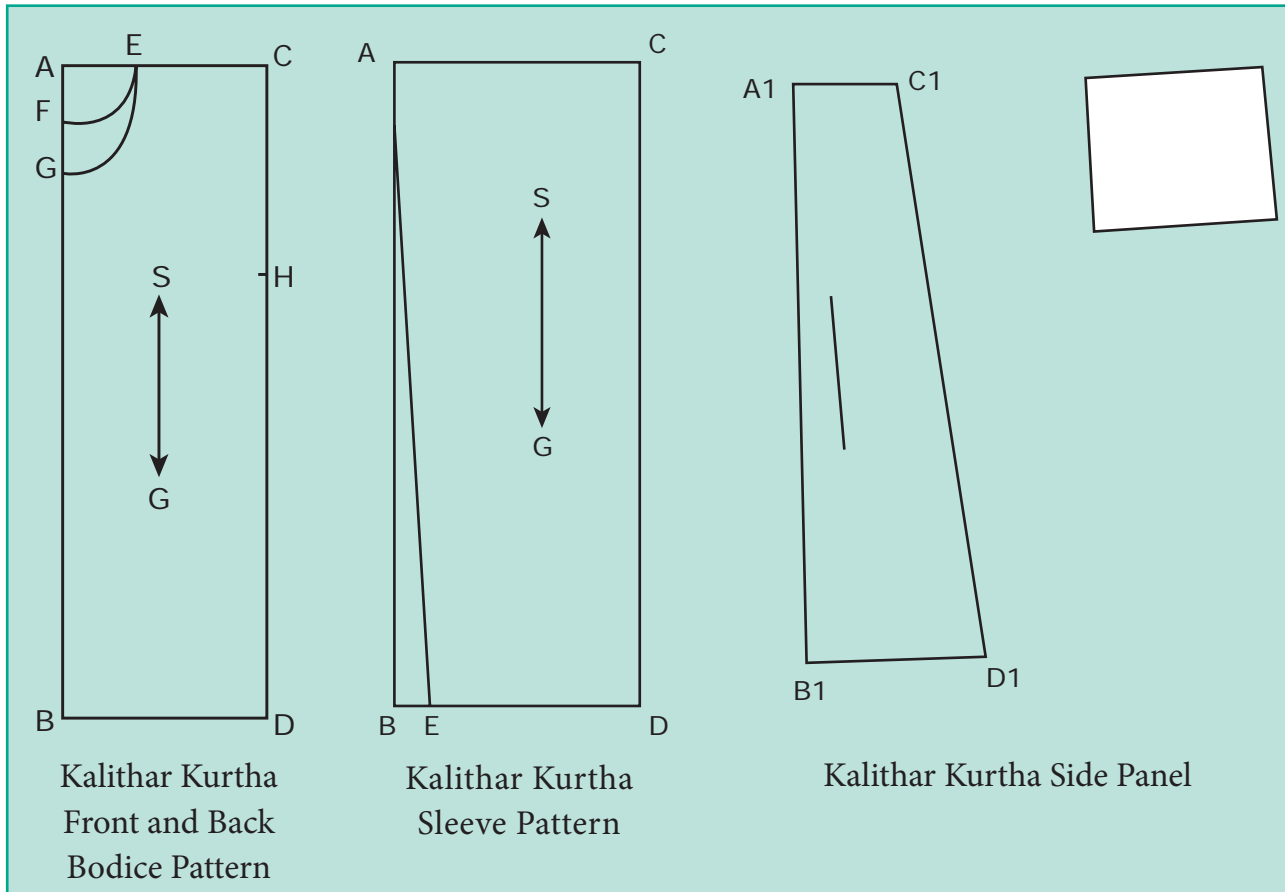

Kalithar kurtha images



Kurtha with Side Slit



Kurtha in Anarkali Style

PROJECT

Any one of the projects can be assigned to the students.

10 marks

A period of 30 days can be given to complete the project.

1. Draft and prepare the instructions construct a Kameez, with minimum two variations.
2. Collect and prepare an album of different types of advertisements in the field of textiles and dress designing.

FIELD TRIP

15 marks

1. Visit an entrepreneur in your city, conduct a survey and collect information about the following:
 - Name of the entrepreneur
 - Address of the entrepreneur
 - Types of products produced by the entrepreneur
 - Number of persons working
 - If received bank loans, if yes give details
 - Type of assets in entrepreneur unit
 - Hurdles or problems faced by the entrepreneur
 - Government
 - Personal
 - Marketing
 - Production
 - Steps taken by the entrepreneur to become successful

Model Question Paper

Textiles and Dress Designing - Practicals

1. Gathered Frock with Puff Sleeve

- a. Write the instruction for drafting Gathered Frock with Puff Sleeve with suitable figure
- b. Draft and cut the paper pattern
- c. Stitch the Gathered Frock with Puff Sleeve
 - (i) Finish the gathers
 - (ii) Finish neckline, hemline and sleeve with piping (or) facing

2. In skirt

- a. Write the instruction for drafting In skirt with suitable figure
- b. Draft and cut the paper portion
- c. Stitch the In skirt
 - (i) Finish the side seams
 - (ii) Finish waistband, and hemlines.

3. Cut Choli

- a. Write the instruction for drafting Cut Choli with suitable figure
- b. Draft and cut the paper pattern
- c. Stitch Cut Choli
 - (i) Attach miter placket at the neck opening
 - (ii) Finish neckline, armcyce

4. T-shirt

- a. Write the instruction for drafting a T-shirt with suitable figure
- b. Draft and cut the paper pattern
- c. Stitch T-shirt
 - (i) Finish placket
 - (ii) Finish neck lines, sleeves, hem lines

5 Salwar

- a. Write the instruction for drafting a Salwar with suitable figure
- b. Draft and cut the paper pattern
- c. Stitch Salwar
 - (i) Finish side seams, gather the bottom of the Salwar.
 - (ii) Finish waist band.

6 kameez

- a. Write the instruction for drafting a Kameez with suitable figure
- b. Draft and cut the paper pattern
- c. Stitch kameez
 - (i) Finish side seams, darts,
 - (ii) Finish neck lines, continuous bound placket, sleeve, facing.

7 Pyjama

- a. Write the instruction for drafting a Pyjama with suitable figure
- b. Draft and cut the paper pattern
- c. Stitch Pyjama
 - (i) Finish side seam.
 - (ii) Finish waist band and cord

8 Kalithar Kurtha

- a Write the instruction for drafting a Kalithar Kurtha with suitable figure
- b Draft and cut the paper pattern
- c Stitch Kalithar Kurtha
 - (i) Attach sleeve, hem lines
 - (ii) Finish neck and side seams.

ALLOCATION OF PERIODS CHAPTERWISE

XII STD – VOCATIONAL SUBJECT

Subject: Textiles and Dress Designing Practical

Month	No. of Periods	No. of Periods for each lesson	Topic (Theory)
June	14	7	Hand Stitches
		7	Machine Stitches
July	21	7	1. Gathered Frock with Puff Sleeve
		7	2. In skirt
		7	3. Cut Choli
		MID TERM	
August	28	14	4. T-shirt
		14	5. Salwar
September		QUARTERLY EXAM	
October	28	14	6. Kameez
		14	7. Pyjama
November	14	14	8. Kalithar Kurtha
		PRE HALF YEARLY EXAM	
December		HALF YEARLY EXAM	
January		REVISION EXAM	

Higher Secondary Class XII

Textiles and Dress Designing - Theory & Practicals

List of Authors and Reviewers

Academic Advisor & Expert

Dr. P. Kumar,
Joint Director (Syllabus),
State Council of Educational Research and Training,
Chennai.

Domain Expert

Dr. S. Amsamani, Professor. (CAS)
Avinashilingam Institute for Home Science and
Higher Education for Women, Coimbatore.

Subject Experts

Dr. G. Bagyalakshmi
Associate Professor & Head,
Avinashilingam Institute for Home Science and
Higher Education for Women, Coimbatore.

Dr. R. Prabha
Assistant Professor (SG)
Avinashilingam Institute for Home Science and
Higher Education for Women, Coimbatore.

Dr. K. Kalaiarasi
Assistant Professor (SG),
Avinashilingam Institute for Home Science and
Higher Education for Women, Coimbatore.

Dr. U. Ratna,
Assistant Professor (SS),
Avinashilingam Institute for Home Science and
Higher Education for Women, Coimbatore.

Academic Co-ordinator

A. Illangovan,
Assitant Professor,
(Dr. Radhakrishnan Awardee-2018)
SCERT, Chennai-06

P.Malarvizhi,
BT Assitant, (Mathematics),
SCERT, Chennai-06

Layout

Arockiam Felix
Chennai

Wrapper Design
Kathir Arumugam

In-House QC
Arun Kamaraj P

Co-ordination
Ramesh Munisamy

Dr. R. Sunitha

Assistant Professor (SS),
Avinashilingam Institute for Home Science and
Higher Education for Women,
Coimbatore

P. Chandra

PG Asst, Girls Hr.Sec. School,
Perambur, Chennai

P.A. Rani

Vocational Teacher TELC,
Hr. Sec.School Usilampatti,
Madurai.

M. Rosaly

Vocational Teacher, Nirmala Girls. Hr.Sec.School,
Madurai.

S. Jeevekani

Vocational Teacher TELC,
Hr. Sec.School Usilampatti,
Madurai.

S. Anees Aysha

PG. Asst, CSI Bain Matriculation HSS,
Kilpauk, Chennai.

EMIS Technology Team

R.M. Satheesh
State Coordinator Technical,
TN EMIS, Samagra Shiksha.

K.P. Sathya Narayana
IT Consultant,
TN EMIS, Samagra Shikaha

R. Arun Maruthi Selvan
Technical Project Consultant,
TN EMIS, Samagra Shiksha

This book has been printed on 80 G.S.M.
Elegant Maplitho paper.

Printed by offset at:



Notes

