

Question Booklet Code :

Register  
Number

--	--	--	--	--	--	--	--	--	--

2019

**ELECTRONICS AND COMMUNICATION ENGINEERING  
(DEGREE Std.)**

Time Allowed : 3 Hours]

[Maximum Marks : 300

Read the following instructions carefully before you begin to answer the questions.

**IMPORTANT INSTRUCTIONS**

1. The applicant will be supplied with Question Booklet 15 minutes before commencement of the examination.
2. This Question Booklet contains 200 questions. Prior to attempting to answer, the candidates are requested to check whether all the questions are there in series and ensure there are no blank pages in the question booklet. **In case any defect in the Question Paper is noticed, it shall be reported to the Invigilator within first 10 minutes and get it replaced with a complete Question Booklet. If any defect is noticed in the Question Booklet after the commencement of examination, it will not be replaced.**
3. Answer **all** questions. All questions carry equal marks.
4. You must write your Register Number in the space provided on the top right side of this page. Do not write anything else on the Question Booklet.
5. An answer sheet will be supplied to you, separately by the Room Invigilator to mark the answers.
6. You will also encode your Question Booklet Code with Blue or Black ink Ball point pen in the space provided on the side 2 of the Answer Sheet. If you do not encode properly or fail to encode the above information, action will be taken as per Commission's notification.
7. Each question comprises *four* responses (A), (B), (C) and (D). You are to select **ONLY ONE** correct response and mark in your Answer Sheet. In case you feel that there are more than one correct response, mark the response which you consider the best. In any case, choose **ONLY ONE** response for each question. Your total marks will depend on the number of correct responses marked by you in the Answer Sheet.
8. In the Answer Sheet there are **four** circles (A), (B), (C) and (D) against each question. To answer the questions you are to mark with Blue or Black ink Ball point pen **ONLY ONE** circle of your choice for each question. Select one response for each question in the Question Booklet and mark in the Answer Sheet. If you mark more than one answer for one question, the answer will be treated as wrong. *e.g.* If for any item, (B) is the correct answer, you have to mark as follows :  

(A) ● (C) (D)
9. You should not remove or tear off any sheet from this Question Booklet. You are not allowed to take this Question Booklet and the Answer Sheet out of the Examination Hall during the time of examination. After the examination is concluded, you must hand over your Answer Sheet to the Invigilator. You are allowed to take the Question Booklet with you only after the Examination is over.
10. **Do not make any marking in the question booklet except in the sheet before the last page of the question booklet, which can be used for rough work. This should be strictly adhered.**
11. Applicants have to write and shade the total number of answer fields left blank on the boxes provided at side 2 of OMR Answer Sheet. An extra time of 5 minutes will be given to specify the number of answer fields left blank.
12. Failure to comply with any of the above instructions will render you liable to such action or penalty as the Commission may decide at their discretion.

SEAL



**SPACE FOR ROUGH WORK**

1. The carrier of an AM signal obtained by sinusoidal modulation to a depth of modulation equal to 1, carries

- (A) 33.33% power (B) 50% power  
 (C) 66.66% power (D) 100% power

2. Convert  $(2AC9)_{16} \rightarrow ( )_7$

- (A)  $(10953)_7$   (B)  $(43635)_7$   
 (C)  $(22953)_7$  (D)  $(63544)_7$

3.

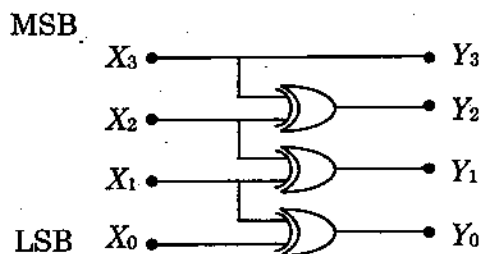

The above logic circuit represents

- (A) Binary to gray converter (B) Binary to octal converter  
 (C) Gray to binary converter (D) Gray to decimal converter

4. The complement of the expression  $Y = ABC + AB\bar{C} + \bar{A}\bar{B}C + \bar{A}BC$  is

- (A)  $\bar{Y} = (\bar{A} + \bar{B})(A + \bar{C})$  (B)  $\bar{Y} = (A + B)(A + \bar{C})$   
 (C)  $\bar{Y} = (A + \bar{B})(A + \bar{C})$  (D)  $\bar{Y} = (\bar{A} + \bar{B})(\bar{A} + \bar{C})$

5. In a uniform plane wave 'E' and 'H' are related by

- (A)  $E/H = 1$  (B)  $E/H = \epsilon/\mu$   
 (C)  $E/H = \sqrt{\mu/\epsilon}$  (D)  $\frac{E}{H} = \infty$

6. 8085 can operate with a \_\_\_\_\_ single phase clock.

- (A) 2 MHz  (B) 3 MHz  
 (C) 10 MHz (D) 7 MHz

7. The general form of the log transformation for intensity functions is given by  
 (A)  $S = c \log(2 + r)$   (B)  $S = c \log(1 + r)$   
 (C)  $S = c \log(6 + r)$  (D)  $S = c \log(4 + r)$
8. \_\_\_\_\_ technique is used for blurring and for noise reduction  
 (A) Smoothing filter (B) Sharpening filter  
 (C) Mask filter (D) Linear filter
9. \_\_\_\_\_ approach is based on the decomposition of an N-point DFT into successively smaller DFTs.  
 (A) Direct computation (B) Radix - 2 FFT  
 (C) Radix - 4 FFT  (D) Divide - and - Conquer approach
10. How many different sequences have a z-transforms given by  

$$H(z) = \frac{1 - 2z^{-1} + 3z^{-2}}{\left(1 - \frac{1}{8}z^{-1} + \frac{1}{4}z^{-2}\right)\left(1 + \frac{1}{3}z^{-1}\right)}$$
  
 (A) One (B) Four  
 (C) Three (D) Two
11. Given  $x[n] = \{1, 1, 1, 1\}$ . DFT of  $x[n]$  is  $X(k) =$   
 (A)  $\{4, 4, 4, 4\}$   (B)  $\{4, 0, 0, 0\}$   
 (C)  $\{4, 0, 4, 0\}$  (D)  $\{0, 4, 0, 4\}$
12. State which of the following statements are true:  
 (i) In bilinear transformation, a linear relationship exists between analog and digital frequencies  
 (ii) In Bilinear transformation, the entire in axis of the s-plane gets mapped onto the unit circle of the z-plane  
 (iii) In Impulse invariant transformation, a nonlinear relationship exists between analog and digital frequencies  
 (A) (i) and (ii) (B) (i)  
 (C) (ii) (D) (ii) and (iii)

13. If an amplifier with gain of  $-1000$  and feedback of  $b = -0.1$  had a gain change of 20% due to temperature, then change in gain of the feedback amplifier would be
- (A) 10% (B) 5%  
 (C) 0.2% (D) 0.01%

14. A circuit using an operational Amplifier shown below has

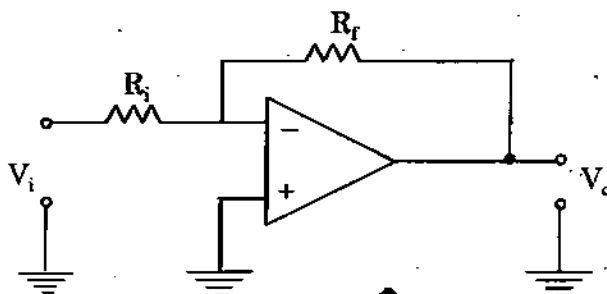

- (A) Voltage series feedback (B)  Voltage shunt feedback  
 (C) Current shunt feedback (D) Current series feedback
15. The dc voltage of a Half-wave rectifier is
- (A)  $V_{dc} = \frac{I_{dc} R_L}{\pi}$  (B)   $V_{dc} = \frac{I_m R_L}{\pi}$   
 (C)  $V_{dc} = \frac{I_m R_L}{2\pi}$  (D)  $V_{dc} = \frac{I_{dc} R_L}{2\pi}$
16. If an *npn* transistor (with  $C = 0.3$  pf) has a unity gain cut-off frequency  $f_T$  of 400 MHz at a dc bias current  $I_c = 1$  MA, then value of its  $C$  is approximately ( $V_T = 26$  mV)
- (A) 15 pf (B) 30 pf  
 (C) 50 pf (D) 96 pf
17. If a two-stage amplifier is required to have an upper cut off frequency of 2 MHz and a lower cut off frequency of 30 Hz then upper and lower cut off frequencies of individual stage are respectively
- (A) 4 MHz, 60 Hz (B)  3 MHz, 20 Hz  
 (C) 3 MHz, 60 Hz (D) 4 MHz, 20 Hz
18. An opamp has a slew rate of 5 v/s. The largest sine wave output voltage positive at a frequency of 1 MHz is
- (A)  $10\pi$  volts (B) 5 V  
 (C)  $\frac{5}{\pi}$  V (D)   $\frac{5}{2\pi}$  V

19. In the base biased transistor circuit, the junction temperature may vary from 25°C to 75°C. If  $\beta$  increase from 100 to 150 with raising temperature, percentage change in  $V_{CE}$  point will be

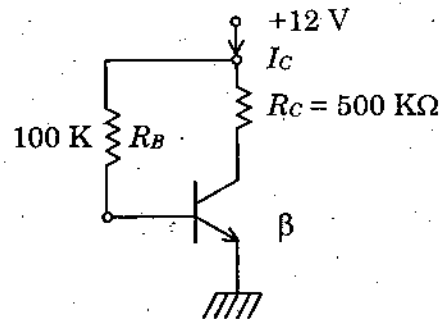

- (A) 40%  
 (B) -44.57%  
 (C) -46.57%  
 (D) -48%

20. When the input signal wave form and the corresponding clamper circuit are as shown in Fig. 1, the DC voltmeter across  $V_0$  indicates.

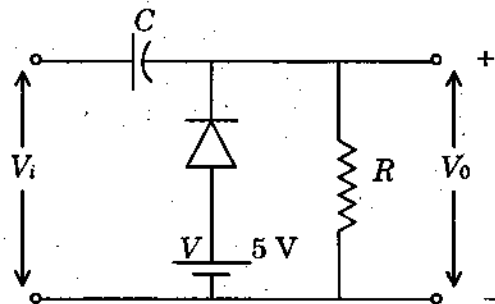
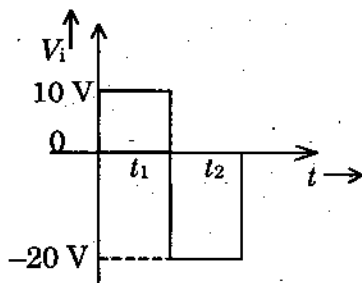

Fig. 1

- (A) -30 V  
 (B) -35 V  
 (C) +35 V  
 (D) +30 V

21. Consider an 8-bit ADC which is capable of accepting an input unipolar voltage (positive values only) 0 to 10 V. If it has an offset error of  $\pm \frac{1}{2}$  LSB, what analog input voltage will cause a digital output code of all 1's?

- (A) 10 V  
 (B) 9 V  
 (C) 9.9804 V  
 (D) 9.5 V

22. For the Gaussian response, the rise time ( $t_r$ ) and bandwidth (BW) are related by
- (A)  $t_r = 0.35/BW$  (B)  $t_r = 0.5/BW$   
 (C)  $BW = 0.35 t_r$  (D)  $t_r = 0.35 BW$
23. In which state, a silicon diode will have a voltage drop of 0.7 V across it?
- (A) No bias  (B) Forward bias  
 (C) Reverse bias (D) Zener Region
24. Doping materials are called impurities because they
- (A) Decrease the number of charge carriers  
 (B) Change the chemical properties of semiconductors  
 (C) Make semiconductors less than 100 percent pure  
 (D) Alter the crystal structure of the pure semiconductors
25. The drift current velocity for holes in a 1 mm length of silicon at 27°C. when the terminal voltage is 10 V. (Electron and Hole Mobility constants are 1500 cm<sup>2</sup> and 500 cm<sup>2</sup> respectively).
- (A) -1500 m/s (B) -500 m/s  
 (C) 500 m/s (D) 1500 m/s
26. The tunneling process in a Tunnel diode is due to
- (A) Physical behaviour (By possession of large energy)  
 (B) Quantum - mechanical behaviour  
 (C) The presence of smaller amounts of impurity atoms  
 (D) Subjecting to very large voltages (in forward and reverse biases)
27. Cascading amplifier stages to obtain a high gain is best done with \_\_\_\_\_.
- (A) Common - emitter stages (B) Common - base stages  
 (C) Common - collector stages (D) (B) and (A)
28. The capacitance of a varactor diode can be changed by
- (A) Increasing its doping level (B) Changing its forward bias  
 (C) Changing its barrier potential  (D) Changing the reverse voltage

29. A given transistor has an  $\alpha$  of 0.98. If the device is connected with its emitter grounded, What will be the change in the collector current for a change of 0.2 mA in the base current?
- (A) .98 mA  
(B) 9.8 mA ✓  
(C) 98 mA  
(D) .098 mA
30. The ultra bright LED's were produced using the material
- (A) gallium arsenide phosphide (GaAsP)  
(B) gallium aluminum arsenide phosphide (GaAlAsP)  
(C) indium gallium aluminum phosphide (InGaAlP) ✓  
(D) gallium phosphide (GaP)
31. In the common-emitter configuration, if the transistor is in the saturation region, then
- (A)  $I_C > I_E$   
(B)  $I_E < I_B$   
(C)  $I_C < \beta I_B$  ✓  
(D)  $I_B > \beta I_C$
32. Mobilities of electrons and holes in a sample of intrinsic germanium at room temperature are  $0.36\text{m}^2/\text{v}\cdot\text{s}$  and  $0.17\text{m}^2/\text{v}\cdot\text{s}$  respectively. If the electron and hole densities are equal to  $2.5 \times 10^{-19}\text{m}^{-3}$ , the germanium conductivity is
- (A)  $0.47\Omega\text{m}$  ✓  
(B)  $0.36\Omega\text{m}$   
(C)  $0.22\Omega\text{m}$   
(D)  $0.01\Omega\text{m}$
33. Temperature coefficient is expressed as
- (A)  $\alpha = \frac{1}{R_o} \cdot \frac{1}{\Delta T} / \text{ohms}/^\circ\text{C}$   
(B)  $\alpha = \frac{1}{R_o} \cdot \frac{\Delta R_o}{\Delta T} \text{ohms}/\text{ohm}/^\circ\text{C}$  ✓  
(C)  $\alpha = \frac{\Delta R_o}{\Delta T} \text{ohms}/^\circ\text{C}$   
(D)  $\alpha = \frac{R_o}{\Delta T} \text{ohm}/^\circ\text{C}$
34. An N-Channel JFET has  $I_{DSS} = 8\text{ mA}$  and  $V_P = -5\text{ V}$ . The minimum value of  $V_{DS}$  for pinch-off region and the drain current  $I_{DS}$  for a  $V_{GS} = -2\text{ V}$  are
- (A) 3 V and 2.88 mA ✓  
(B) -5 V and 1.88 mA  
(C) -2 V and 3.12 mA  
(D) -7 V and 1.98 mA
35. The current of a certain Si-diode, when measured with a large reverse bias is found to be 10 nA. What would be the current be if a forward bias of 2V is applied? Assume that  $T = 300^\circ\text{K}$ ,  $\eta = 2$ .
- (A)  $6.2 \times 10^8\text{ A}$  ✓  
(B)  $6.2 \times 10^{-8}\text{ A}$   
(C)  $.62 \times 10^8\text{ A}$   
(D)  $.62 \times 10^{-8}\text{ A}$



36. Optical carrier frequency is in the range
- (A)  $10^9$  to  $10^{11}$  Hz (B)  $10^{10}$  to  $10^{12}$  Hz  
 (C)  $10^{13}$  to  $10^{16}$  Hz (D)  $10^9$  to  $10^{12}$  Hz
37. The biggest disadvantage of the IMPATT diode is its
- (A) high noise  
 (B) lower efficiency  
 (C) inability to provide pulsed operation  
 (D) low power-handling capability
38. Nonlinearity will affect very critically
- (A) TDMA scheme  (B) FDMA scheme  
 (C) SDMA scheme (D) CDMA scheme
39. Coherent radiation in LASER is caused by
- (A) Stimulated emission (B) Spontaneous emission  
 (C) Temperature increase (D) Applying large force
40. A planet nine times far away from Sun as compared to earth, has an orbital period of
- (A) 9 Earth years  (B) 27 Earth years  
 (C) 729 Earth years (D) 81 Earth years
41. \_\_\_\_\_ algorithm performs maximum likelihood decoding of convolutional codes
- (A) Fano's (B) Hadmard  
 (C) Viterbi (D) Shannon
42. For cellular Digital Packet Data systems, channel Data Rate is
- (A) 18,300 bps  (B) 19,200 bps  
 (C) 17,500 bps (D) 20,100 bps
43. Which of the following property applicable to frequency selective fading?
- (A) BW of signal > BW of channel  
 (B) Delay spread > symbol period  
 (C) BW of signal < BW of channel  
 (D) Both (A) and (B)

44. Find the far-field distance for an antenna with maximum dimension of 1 m and operating frequency of 900 MHz
- (A) 6 m (B) 5 m  
(C) 9 m (D) 10 m
45. To couple two generators to a wave guide without coupling than to each other, we use
- (A) E plane T (B) Hybrid ring  
(C) Magnic T (D) Rate race
46. The TWT is sometimes preferred to the multicavity klystron amplifier, because it
- (A) has a greater bandwidth  
(B) has a higher number of modes  
(C) is more efficient  
(D) produces higher output power
47. The concept used in the scheme of WDM is similar to
- (A) FDM for of transmission (B) SDM  
(C) TDM (D) OTOM
48. Assuming zero initial condition, the response  $y(t)$  of the following system for a unit step input  $u(t)$  is

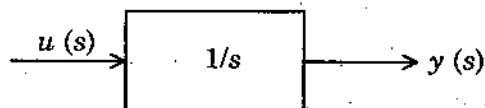

- (A)  $u(t)$   (B)  $t u(t)$   
(C)  $\frac{t^2}{2} u(t)$  (D)  $e^{-t} u(t)$
49. If any of the coefficients in a characteristic polynomial are zero or negative in the presence of at least one positive coefficient, then the system is
- (A) Unstable (B) Stable  
(C) Marginally stable (D) Asymptotically stable

50. The root locus of a system has 4 separate root loci. The system can have  
 (A) Four poles and two zeroes  (B) Four poles and four zeroes  
 (C) Six poles and two zeroes (D) Four poles and three zeroes
51. The value of A matrix for the system described by the differential equation  
 $\frac{d^2y}{dt^2} + 2\frac{dy}{dt} + 3y = 0$  is  
 (A)  $\begin{bmatrix} 1 & 0 \\ -3 & -2 \end{bmatrix}$  (B)  $\begin{bmatrix} 1 & 0 \\ -2 & -1 \end{bmatrix}$   
 (C)  $\begin{bmatrix} 1 & 0 \\ -1 & -2 \end{bmatrix}$  (D)  $\begin{bmatrix} 1 & 0 \\ -2 & -3 \end{bmatrix}$
52. The system with the open loop transfer function  $G(s)H(s) = \frac{1}{s(s^2 + s + 1)}$  has a gain margin of  
 (A) -6 dB  (B) 0 dB  
 (C) 3.5 dB (D) 6 dB
53. For the signal flow graph representing a feedback system subjected to a disturbance  $w(s)$ , the transfer function relating  $y(s)$  to  $w(s)$  with  $R(s) = 0$

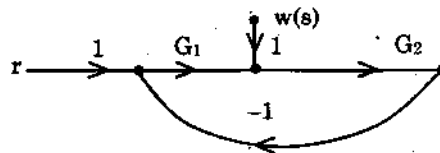

- (A)  $(G_1 G_2)/(1 + G_1 G_2)$  (B)  $G_1 G_2/(1 - G_1 G_2)$   
 (C)  $G_2/(1 + G_1 G_2)$   (D)  $\frac{G_2}{(1 - G_1 G_2)}$
54. Systems having a finite non-zero steady state error to a parabolic input is called as  
 (A) Type - 0 System (B) Type - 1 System  
 (C) Type - 2 System (D) Type - 3 System
55. Consider the following statements: Lead compensator  
 1. increases the margin of stability  
 2. Speeds up transient response  
 3. does not affect the system error constant  
 of these statements  
 (A) 2 and 3 are correct  (B) 1 and 2 are correct  
 (C) 1 and 3 are correct (D) 1, 2 and 3 are correct

56. In 8051, Match the following

Branch Instruction	Addressing	Jumping distance
(a) LJMP	(i) Relative	(W) 11 bits
(b) AJMP	(ii) Indirect	(X) 16 bits
(c) SJMP	(iii) Direct	(Y) 8 bits
(d) JMP @ A+DPTR	(iv) Direct	(Z) 16 bits

- (A) a(iii)X, b(iv)W, c(i)Y, d(ii)Z  
 (B) a(ii)W, b(iii)X, c(iv)Y, d(i)Z  
 (C) a(iv)Z, b(iii)Y, c(ii)X, d(i)W  
 (D) a(i)W, b(ii)X, c(iii)Y, d(iv)Z

57. Considering figure 1, if SI = 1000 H, the content of register AH after the instruction MOV AH, [SI] of 8086  $\mu p$  will be

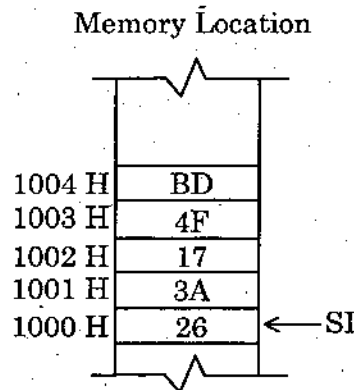

Figure 1

- (A) 1000       (B) 26  
 (C) 3A        (D) 1001

58. The value of register AL following the instruction sequence :

MOV AL, 5

NEG AL is

- (A) FAH       (B) FBH  
 (C) FCH      (D) FDH

59. In 8086 instruction set, the instructions to adjust the product to unpacked BCD digits during multiplication/division are
- (A) IMUL, MUL (B) IDIV, DIV  
 (C) AAM, AAD (D) SHL, SAL
60. A microprocessor with 24 bit address bus could potentially access
- (A) 16,777,216 memory locations (B) 8,388,608 memory locations  
 (C) 65,536 memory locations (D) 1,048,576 memory locations
61. The program which translates the mnemonics entered by the ASCII keyboard into the corresponding binary machine codes of the microprocessor is called
- (A) Assembler (B) Interpreter  
 (C) M - Basic (D) C Program
62. \_\_\_\_\_ port does not have pull-up resistors in 8051.
- (A) Port 0 (B) Port 1  
 (C) Port 2 (D) Port 3
63. After assembly in 8086, any errors in program syntax can be found by examining the \_\_\_\_\_ file.
- (A) List (B) Source  
 (C) Main (D) Object
64. The 8085 supports \_\_\_\_\_ number of instructions, with \_\_\_\_\_ number of addressing modes and operates at \_\_\_\_\_ MHz frequency.
- (A) 74, 5, 3 (B) 256, 4, 6  
 (C) 74, 4, 6 (D) 256, 5, 6
65. When the effect of inter symbol interference is severe, the eye (in the eye pattern) is,
- (A) wide open  (B) completely closed  
 (C) having a great height (D) having moderate height
66. Optical storage devices employ
- (A) Ultraviolet light (B) Optical couplers  
 (C) Electromagnetic field (D) Lasers



67. Obtain the phase states of the carrier when the bit stream 1001101100 is applied to a QPSK modulator
- (A)  $0^\circ, 90^\circ, 180^\circ, 180^\circ, 270^\circ$  (B)  $90^\circ, 90^\circ, 180^\circ, 0^\circ, 270^\circ$   
(C)  $270^\circ, 90^\circ, 0^\circ, 180^\circ, 90^\circ$  ~~(D)  $180^\circ, 90^\circ, 180^\circ, 270^\circ, 0^\circ$~~
68. Twenty four different message signals each band limited to 4 KHz are to be multiplexed with FDM – SSB modulation. The minimum band width required is,
- (A) 48 KHz (B) 192 KHz  
~~(C) 96 KHz~~ (D) 120 KHz
69. In slow frequency hopping, (when  $R_h$  is frequency hopping rate,  $R_b$  is symbol rate)
- (A)  $R_h < R_b$  ~~(B)  $R_h \leq R_b$~~   
(C)  $R_h > R_b$  (D)  $R_h \geq R_b$
70. Noise performance of PAM is
- (A) better than direct baseband transmission  
(B) better than CW amplitude modulation  
~~(C) poorer than direct baseband transmission~~  
(D) better than that of PDM
71. In general cross-talk decreases with increasing bandwidth
- ~~(A) it reduces more rapidly in PPM than PAM~~  
(B) it reduces more rapidly in PAM than PPM  
(C) it reduces at the same rate in PAM and PPM  
(D) it reduces more rapidly in PAM compared to PPM and PWM
72. 0110001 and 0101100 are said to be valid code words of a linear code,
- ~~(A) if 0011101 is a valid codeword~~  
(B) if 1001110 is a valid codeword  
(C) if 1010011 is a valid codeword  
(D) if 1100010 is a valid codeword
73. If a 1 MHz carrier is simultaneously modulated with 300 Hz and 2 KHz audio sine waves, the frequency which will not be present in output is
- (A) 998 KHz (B) 999.7 KHz  
(C) 1000.3 KHz ~~(D) 700 KHz~~

74.	Types of Modulation	Quadrature component
(a)	SSB-SC upper sideband	1. $-\frac{1}{2} \hat{m}(t)$
(b)	SSB-SC lower sideband	2. $-\frac{1}{2} m'(t)$
(c)	VSB lower sideband	3. $\frac{1}{2} \hat{m}(t)$
(d)	VSB upper sideband	4. $\frac{1}{2} m'(t)$

$\hat{m}(t)$  = Hilbert transform of  $m(t)$

$m'(t)$  = output of the filter of frequency response  $H_Q(f)$  due to  $m(t)$

The correct match is

	(a)	(b)	(c)	(d)
(A)	1	2	3	4
<input checked="" type="checkbox"/> (B)	3	1	4	2
(C)	2	3	4	1
(D)	4	1	2	3

75.

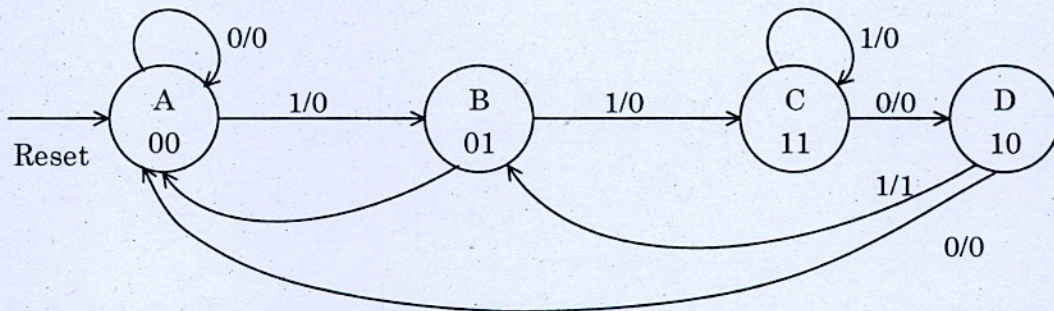

For an input of 001110 the above state machine produces the output and states of

(A)	0 0 1 0 1 0	A A B C D D
(B)	0 1 0 1 0 1	A B B C D A
(C)	0 0 0 0 1 0	A A B C D D
<input checked="" type="checkbox"/> (D)	0 0 0 0 0 0	A A B C C D



76. The state diagram depicts the truth table of

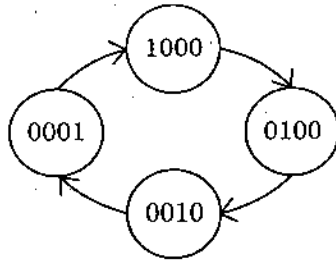

- (A) Johnson counter  
 (B) Ring counter  
(C) Up counter  
(D) Ripple counter

77. The minimum number of NAND gates required to implement  $A + AB\bar{B} + A\bar{B}C$  is equal to

- (A) 0  
(B) 1  
(C) 4  
(D) 7

78. When signed numbers are used in binary arithmetic, then which of the following notation has unique representation for zero?

- (A) sign magnitude  
(B) 1's complement  
(C) 2's complement  
(D) 10's complement

79. An eight track magnetic tape runs at a speed of 120 inches per second with the density of 1600 bits per inch. Obtain its transfer rate in characters/second

- (A) 13.33 characters/sec  
(B) 192000 characters/sec  
(C) 1720 characters/sec  
(D) 1480 characters/sec

80.  $1024 \times 1$  capacity RAM chips are available for a PC system, which requires a memory capacity of 1024 bytes. Find out the number of RAM chips.

- (A) 1  
(B) 2  
(C) 4  
(D) 8

81. If a programmable Array Logic (PAL) has 10 input pins, the number of inputs to each of the AND gates is

- (A) 10  
(B) 5  
(C) 1  
(D) 20

82. The cascade of divide by 5 counter followed by divide by 2 counter is in state 0000. When a clock pulse is applied, its state will be

- (A) 0001  
(B) 0010  
(C) 0100  
(D) 1000

83. Fourier series coefficients of the signal  $x(t) = 3 \cos\left(\frac{\pi}{4}t + \frac{\pi}{6}\right)$  is
- (A)  $a_1 = \frac{3}{2}e^{j\pi/6}; a_{-1} = \frac{3}{2}e^{-j\pi/6}$  (B)  $a_1 = 3e^{j\pi/4}; a_{-1} = 3e^{-j\pi/4}$   
 (C)  $a_1 = 3e^{j\pi/6}; a_{-1} = 3e^{-j\pi/6}$  (D)  $a_1 = \frac{3}{2}e^{j\pi/4}; a_{-1} = \frac{3}{2}e^{-j\pi/4}$
84. An LTI system is stable if and only if the ROC of its system function  $H(s)$  includes the  $j\Omega$  axis, i.e.
- (A)  $\text{Re}\{S\} \neq 0$  (B)  $\text{Re}\{S\} = 0$   
 (C)  $\text{Re}\{S\} > 0$  (D)  $\text{Re}\{S\} < 0$
85. Given the frequency response  $H(e^{j\omega}) = \frac{1}{1 - 2e^{-j\omega}}$ . Find the difference equation representation of the system.
- (A)  $y(n) + 2y(n-1) = x(n)$  (B)  $y(n) - 2y(n-1) = x(n)$   
 (C)  $x(n) + 2x(n-1) = y(n)$  (D)  $x(n) - 2x(n-1) = y(n)$
86. Given the analog signal  $x(t) = 2 \sin 100\pi t$ . Suppose the signal is sampled at a rate of  $F_s = 75\text{Hz}$ . What is the discrete time signal obtained after sampling?
- (A)  $\sin \frac{4\pi}{3}n$  (B)  $2 \sin \frac{4\pi}{3}n$   
 (C)  $\sin \frac{3\pi}{4}n$  (D)  $2 \sin \frac{3\pi}{4}n$
87. For a parallel RLC Circuit the critical damping is defined as
- (A)  $L = R^2C$  (B)  $L = 4R^2C$   
 (C)  $L = 2RC$  (D)  $L = 2R^2C$
88. When two coils are connected in parallel and a voltage of 200 V is applied between the terminals, the total current taken by the circuit is 25 A and power dissipated in one of the coil is 1500 W, the resistance of each coil is
- (A)  $25\Omega$  and  $5\Omega$  (B)  $26.67\Omega$  and  $11.43\Omega$   
 (C)  $0.25\Omega$  and  $4.75\Omega$  (D)  $35\Omega$  and  $5\Omega$
89. The half power frequencies of an RLC series circuit consisting of  $R = 50\Omega$ ,  $L = 0.16\text{H}$  and  $C = 4\mu\text{F}$  are
- (A)  $f_L = 200\text{Hz}$  and  $f_H = 250\text{Hz}$  (B)  $f_L = 198.9\text{Hz}$  and  $f_H = 225.3\text{Hz}$   
 (C)  $f_L = 150.1\text{Hz}$  and  $f_H = 300.5\text{Hz}$  (D)  $f_L = 100\text{Hz}$  and  $f_H = 250\text{Hz}$

90. The values of currents in the circuit shown in Fig. 1 are

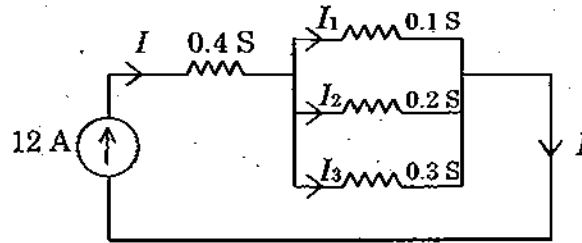

Fig 1

- (A)  $I_1 = 2 \text{ A}, I_2 = 4 \text{ A}; I_3 = 6 \text{ A}$       (B)  $I_1 = 3 \text{ A}, I_2 = 5 \text{ A}; I_3 = 4 \text{ A}$   
 (C)  $I_1 = 2.5 \text{ A}, I_2 = 3.5 \text{ A}; I_3 = 6 \text{ A}$       (D)  $I_1 = 1 \text{ A}, I_2 = 6 \text{ A}; I_3 = 5 \text{ A}$
91. A coil of inductance 25 mH and resistance 20  $\Omega$  is connected parallel to a capacitor and this parallel combination is connected to a 200 V, 40 Hz supply. The value of capacitor if no reactive current is taken from the supply is

- (A) 57 pF       (B) 57  $\mu\text{F}$   
 (C) 57 nF      (D) 57 mF

92. The value of  $R_L$  and dynamic resistance for resonance in the network shown in Fig. 1.

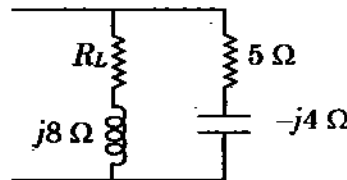

Fig 1

- (A)  $R_L = 4.24 \Omega$  and  $R_{dynamic} = 5.76 \Omega$       (B)  $R_L = 5.76 \Omega$  and  $R_{dynamic} = 4.24 \Omega$   
 (C)  $R_L = 5.1 \Omega$  and  $R_{dynamic} = 7.29 \Omega$       (D)  $R_L = 42.4 \Omega$  and  $R_{dynamic} = 57.6 \Omega$
93. A Voltage  $100\sin(20t)$  is applied to a coil. At  $t = 0$  the magnitude of transient term is 0.4 A and it delays with a time constant of 0.5 seconds. The value of R and L of the coil are
- (A)  $R = 10 \Omega$      $L = 10 \text{ H}$        (B)  $R = 25 \Omega$      $L = 12 \text{ H}$   
 (C)  $R = 15 \Omega$      $L = 12 \text{ H}$       (D)  $R = 35 \Omega$      $L = 12 \text{ H}$
94. Broadside Array antenna with array length  $l = 20\lambda$ , number of elements.  $N = 100$ . The beam width of major lobe between first null and major lobe maxima is given by
- (A) 0.1 radian      (B) 0.2 radian  
 (C) 2 radian      (D) 10 radian



95. A plane electromagnetic wave is travelling in an unbounded loss-less dielectric having  $\mu_r = 1$  and  $\epsilon_r = 4$ . The time averaged poynting vector of the wave is  $5 \text{ W/m}^2$ . Assuming velocity of light as  $3 \times 10^8 \text{ m/s}$ , phase velocity  $v_p$  is
- (A)  $0.75 \times 10^8 \text{ m/s}$  (B)  $20 \times 10^8 \text{ m/s}$   
~~(C)~~  $1.5 \times 10^8 \text{ m/s}$  (D)  $0.6 \times 10^8 \text{ m/s}$
96. The inconsistency of continuity equation for time varying field was corrected by Maxwell and the correction was applied to
- (A) Ampere's law by adding term  $\frac{\partial D}{\partial t}$   
 (B) Gauss's law by adding term  $J$   
 (C) Faraday's law by addition of term  $\frac{\partial B}{\partial t}$   
 (D) Ampere's law by adding term  $\frac{\partial P}{\partial t}$
97. Antenna radiation efficiency can be increased by
- (A) Reducing radiation resistance of the system  
 (B) Increasing radiation resistance of the system  
 (C) Providing effective earthing  
 (D) All of the above
98. Which of these statements is not characteristic of a static magnetic field?
- (A) It is solenoidal  
 (B) It is Conservative  
 (C) It has no sinks or sources  
 (D) Magnetic flux lines are always closed
99. The dominant mode for rectangular waveguides is
- (A)  $\text{TE}_{11}$  (B)  $\text{TM}_{11}$   
 (C)  $\text{TE}_{10}$  (D)  $\text{TE}_{101}$
100. At microwave frequencies, waveguides are preferred to transmission lines for transporting EM energy because of all the following except that
- (A) Losses in transmission lines are prohibitively large  
 (B) Waveguides have larges bandwidths & lower signal attenuation  
 (C) Transmission lines are larger in size than waveguides  
 (D) Transmission lines support only TEM mode

101. Compared to CE and CC amplifier, the CB amplifier has
- (A) lower input resistance                      (B) a much larger voltage gain  
 (C) a large current gain                      (D) a higher input resistance
102. The percentage of power saving of 100% modulated suppressed carrier AM signal is
- (A) 100%                      (B) 83.33%  
 (C) 50%                      (D) 66.66%
103. An angle modulated signal with carrier frequency  $\omega_c = 2\pi \times 10^5$  is described by  $y_{\text{anglemod}}(t) = 10 \cos(\omega_c t + 5 \sin 3000t + 10 \sin 1000 \pi t)$ . With unit resistance, the power of the modulated signal is
- (A) 50 W                      (B) 12.50 W  
 (C) 100 W                      (D) 25 W
104. The transmission bandwidth required for a PCM signal (with 4 KHz maximum input signal and 8 bit encoding) is
- (A) 32 KHz                      (B) 64 KHz  
 (C) 4 KHz                      (D) 8 KHz
105. The PSD of the Manchester line code
- (A) may or may not have zero null depending on choice of pulse  
(B) has the factor  $P(\omega)$   
 (C) does not have dc null  
 (D) has a dc null
106. Communication satellite assembles the telephone channels using
- (A) TDM                       (B) FDM  
 (C) both TDM and FDM                      (D) CDMA
107. What is the bit duration of a 2.5 G bits/s signal?
- (A) 2.5 ns                      (B) 1 ns  
 (C) 0.4 ns                      (D) 0.1 ns
108. The layer concerned with transmitting raw bits over a communication channel is
- (A) data link layer                      (B) application layer  
 (C) transport layer                       (D) physical layer

109. Limit cycle oscillations occur
- (A) only in recursive systems
  - (B) only in non-recursive systems
  - (C) in both recursive and non-recursive systems
  - (D) in FIR and IIR filters
110. FIR filters can be designed using
- (A) windowing method
  - (B) bilinear transformation
  - (C) impulse invariant transformation
  - (D) windowing and frequency sampling methods
111. \_\_\_\_\_ is an attribute associated with the dominant wavelength in a mixture of light waves.
- (A) Brightness
  - (B) Hue
  - (C) Contrast
  - (D) Saturation
112. What is the value of magnitude frequency response of Butterworth low pass filter at  $\Omega = 0$ ?
- (A) 1
  - (B)  $\frac{1}{\sqrt{2}}$
  - (C) 0
  - (D) 2
113. \_\_\_\_\_ signal is a signal exhibiting no uncertainty of value at any given instant of time.
- (A) Deterministic
  - (B) Random
  - (C) Continuous-time
  - (D) Discrete-time
114. If the Nyquist rate for  $x_a(t)$  is  $\Omega_s$ . Find the Nyquist rate for  $x^2(2t)$
- (A)  $3 \Omega_s$
  - (B)  $4 \Omega_s$
  - (C)  $\Omega_s$
  - (D)  $2 \Omega_s$
115. The overall process of truncating, quantizing and coding the coefficients of a transformed subimage is called as
- (A) bit allocation
  - (B) vector allocation
  - (C) magnitude allocation
  - (D) byte allocation

116. Consider the following system

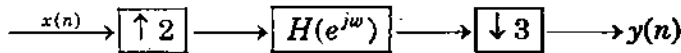

$H(e^{j\omega})$  is a \_\_\_\_\_ with band limited frequency \_\_\_\_\_

- (A) low pass filter,  $\pi/2$                        (B) low pass filter,  $\pi/3$   
 (C) low pass filter,  $\pi/6$                       (D) low pass filter,  $\pi/5$

117. Find the system function for the following network, where  $az^{-1}$  is a unit delay combined with a multiplication by 'a':

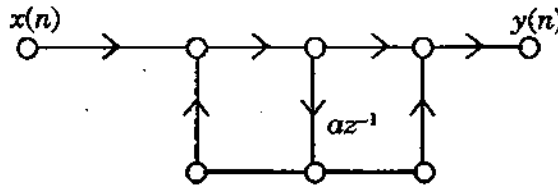

- (A)  $1 + az^{-1} / 1 - az^{-1}$                       (B)  $1 + az^{-1} / 1 - az^{-1}$   
 (C)  $1 + az / 1 - az$                               (D)  $1 + az / 1 + az$

118. Bilinear transformation maps the point  $S = \infty$  into the point

- (A)  $Z = 0$      (B)  $Z = -1$   
 (C)  $Z = 1$     (D)  $Z = 2$

119. Given  $h[n] = \{1, 2, 3, 2, 1\}$ . It is a linear phase FIR filter because

- (A)  $h[n] = h[N-1-n]$                       (B)  $h[n]$  has finite number of samples  
 (C)  $h[n] = -h[N-1-n]$                       (D)  $h[n] = h[N-n]$

120. Consider the two different ways of cascading a decimator with an interpolator shown below

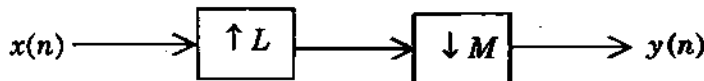
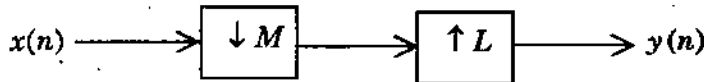

The two systems are identical if

- (A)  $M > L$      (B) M and L are relatively prime  
 (C)  $M = L$     (D)  $M \neq L$

121. A multistage amplifier employs five stages each of which has a power gain of 30. The total power gain of the amplifier in dB is

- (A) 73.85 dB (B) 78.35 dB  
(C) 75.38 dB (D) 72.35 dB

122. The critical value of inductance used in a L-section filter of rectifier is given

- (A)  $L_c = \frac{R_L}{3\omega}$  (B)  $L_c = \frac{2R_L}{\omega}$   
(C)  $L_c = \frac{2}{3} \frac{\omega}{R_L}$  (D)  $L_c = \frac{1}{3} \frac{\omega}{R_L}$

123. The output voltage for the open loop differential amplifier of given figure is  
(Assume  $V_{in1} = 5\mu\text{VDC}$ ,  $V_{in2} = -7\mu\text{VDC}$ ,  $A = 200,000$ )

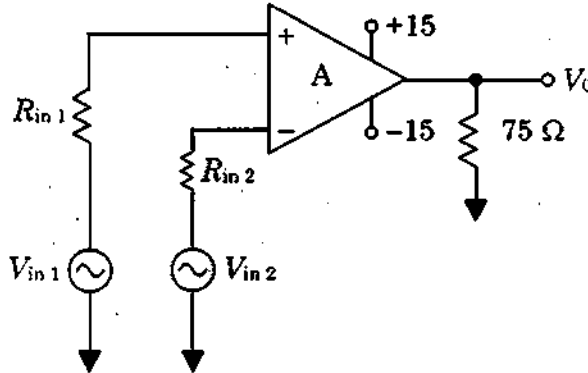

- (A) 10 V (B)  2.4 V  
(C) -20 V (D) -1.4 V

124. In a positive feedback amplifier the phase difference between input signal and feedback signal is

- (A)  $0^\circ$  (B)  $180^\circ$   
(C)  $270^\circ$  (D)  $90^\circ$

125. The Barkhausen criterion states that for oscillation to occur in a feedback loop, at a particular frequency

- (A) There must be a positive feedback  
 (B) The magnitude of the loop gain must be 1 and phase shift must be  $360^\circ$   
(C) The magnitude of the loop gain must be greater than unity when the phase shift is less than  $360^\circ$   
(D) The magnitude of the loop gain must be greater than zero when phase shift is  $180^\circ$





131. A certain transistor has  $\alpha_{dc}$  of 0.98 and a collector leakage current  $I_{co}$  of  $1\mu A$ . When  $I_E = 1mA$ , the collector and base currents will be

- (A)  $I_c = 0.981 mA$  and  $I_B = 0.019 mA$     (B)  $I_c = 0.981 \mu A$  and  $I_B = 0.019 \mu A$   
 (C)  $I_c = 9.81 mA$  and  $I_B = 0.19 mA$     (D)  $I_c = 9.81 \mu A$  and  $I_B = 0.19 \mu A$

132. A zener diode with  $V_Z = 4.3 V$  has  $Z_Z$  equal to  $22 \Omega$  when  $I_Z = 20 mA$ . The upper and lower limits of  $V_Z$  when  $I_Z$  changes by  $\pm 5 mA$  is

- (A)  $V_{z(max)} = 4.41V$  and  $V_{z(min)} = 4.19 V$     (B)  $V_{z(max)} = 4.19V$  and  $V_{z(min)} = 4.41 V$   
 (C)  $V_{z(max)} = 4.3V$  and  $V_{z(min)} = 4.2 V$     (D)  $V_{z(max)} = 4.51V$  and  $V_{z(min)} = 4.29 V$

133. The output voltage  $V_o$  of the below circuit will be

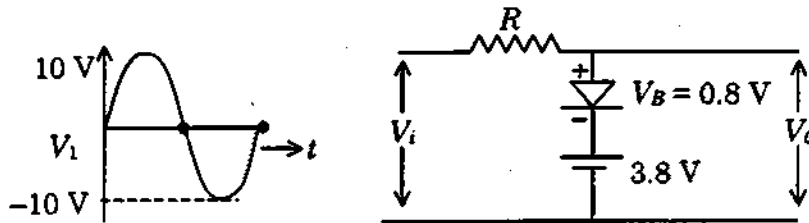

- (A)
- (C)

- (B)
- (D)

134. A two terminal negative resistance device that can be employed in an amplifier, oscillator (or) switch.

- (A) Esaki diode    (B) Tunnel diode  
 (C) Varactor diode     (A) and (B)

135. The symbol in figure 1 is

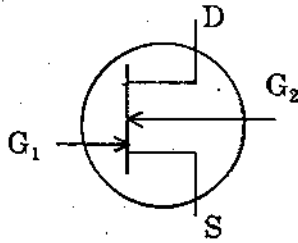

- (A) diode connected FET  
 (C) tetrode connected FET  
 (B) triode connected FET  
 (D) pentode connected FET

136.

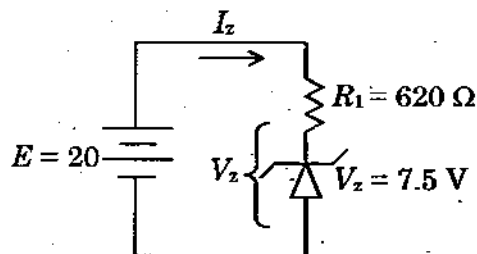

For the circuit in above figure the zener current  $I_z$  and power dissipation are

- (A) 20.16 mA and 151 mW  
 (B) 20.16 A and 151 W  
 (C) 2.016 mA and 151 W  
 (D) 20.16 mA and 151 W

137. The transistor shown in figure is specified to have  $\beta$  in the range of 50 to 150. Find the value of  $R_B$  that results in saturation with an overdrive factor of atleast 10

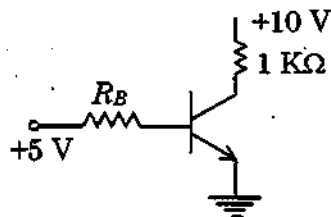

- (A) 2.2 K Ω  
 (B) 3.2 K Ω  
 (C) 3.4 K Ω  
 (D) 2.8 K Ω

138. Friis free space equation is given as

(A)  $P_r(d) = \frac{P_t G_t G_r \lambda^2}{(4\pi)^2 d^2 L}$

(B)  $P_r(d) = \frac{P_t G_t G_r}{(4\pi)^2 d^2 L}$

(C)  $P_r(d) = \frac{P_t G_t G_v \lambda}{(4\pi)^2 d^2 L}$

(D)  $P_r(d) = \frac{P_t G_t G_v \lambda^2}{4\pi \cdot d^2 \cdot L}$

139. The main drawback of the two hole directional coupler is

(A) low directional coupling

(B) poor directivity

(C) high SWR

(D) narrow bandwidth

140. The RAKE receiver is essentially a diversity receiver designed specially for

(A) TDMA

(B) FDMA

(C) CDMA

(D) OFDM

141. \_\_\_\_\_ modulation methods are being explored for high speed data connections as part of the IEEE 802.11a standards activities to provide 54 Mbps WLAN

(A) FDMA, MFSK

(B) TDMA, FDMA

(C) OFDM, MFSK

(D) TDMA, OFDM

142. The bit error probability for GMSK is given by

(A)  $P_e = \frac{1}{2} \left\{ \sqrt{\frac{2\nu E_b}{N_0}} \right\}$

(B)  $P_e = Q \left\{ \sqrt{\frac{2\nu E_b}{N_0}} \right\}$

(C)  $P_e = \frac{\sqrt{2\nu E_b}}{N_0}$

(D)  $P_e = Q^2 \left\{ \sqrt{\frac{2\nu E_b}{N_0}} \right\}$

143. The number of simultaneous users that can be accommodated in GSM is given as

(A) 1000 simultaneous users

(B) 1500 simultaneous users

(C) 2000 simultaneous users

(D) 850 simultaneous users

144. The number of samples in a vector is called the dimension  $L$  of the vector quantizer. The rate  $R$  of the vector quantizer is defined as

(A)  $R = \log n^2 / L$  bits/sample

(B)  $R = \log n \cdot L$  bits/sample

(C)  $R = \frac{\log_2^n}{L}$  bits/sample

(D)  $R = \log n / L$  bits/sample

145. For the transfer function  $G(j\omega) = 5 + j\omega$  the corresponding Nyquist plot for the positive frequency has the form

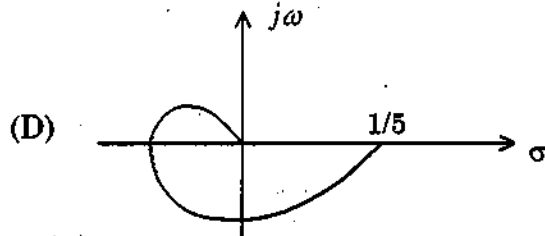
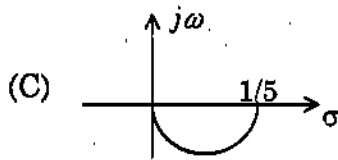
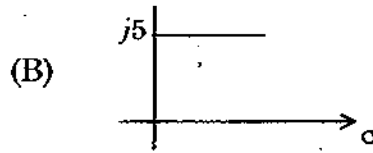
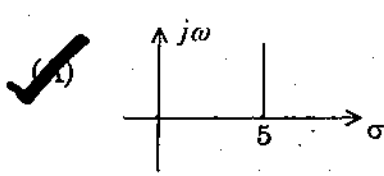

146. When two networks are cascaded, the overall transfer function  $E_4(s)/E_1(s)$  is given by

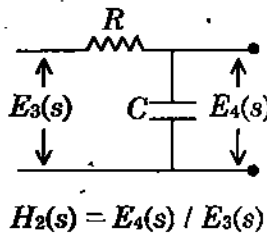
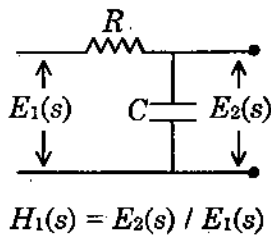

(A)  $H_1(s) + H_2(s)$

(B)  $\frac{H_2(s)}{H_1(s)}$

(C)  $H_1(s) \cdot H_2(s)$

(D)  $H_1(s) * H_2(s)$  (\* - convolution)

147. A unity feedback system has open-loop transfer function  $G(s)$ . The steady-state error is zero for

(A) ramp input and type - 0  $G(s)$

(B) ramp input and type - 1  $G(s)$

(C) step input and type - 0  $G(s)$

(D) step input and type - 1  $G(s)$

148. The phase angle of the system  $G(s) = \frac{s+5}{s^2+4s+9}$  varies between

(A)  $-90^\circ$  and  $-180^\circ$

(B)  $0^\circ$  and  $+90^\circ$

(C)  $0^\circ$  and  $-90^\circ$

(D)  $90^\circ$  and  $180^\circ$

149. Given the transfer function of a casual system  $H(s) = \frac{s}{s^2 + 5s + 6}$ . The system is stable because

- (A) all the poles lie in the left half of s-plane
- (B) all the poles lie in the right-half of the s-plane
- (C) all the poles lie on the imaginary axis
- (D) all the poles and zeros lie on the imaginary axis

150. A necessary condition for applying the Nyquist criterion is that the Nyquist contour

- (A) must not pass through any poles of  $1 + G(s) H(s)$  plane
- (B) must not pass through any zeros of  $1 + G(s) H(s)$  plane
- (C) must not pass through any poles or zeros of  $1 + G(s) H(s)$  plane
- (D) must pass through any poles of  $1 + G(s) H(s)$  plane

151. Given  $A = \begin{bmatrix} 1 & 0 \\ 0 & 1 \end{bmatrix}$  the state transition matrix  $e^{At}$  is given by

- (A)  $\begin{bmatrix} 0 & e^{-t} \\ e^{-t} & 0 \end{bmatrix}$
- (B)  $\begin{bmatrix} e^{-t} & 0 \\ 0 & e^{-t} \end{bmatrix}$
- (C)  $\begin{bmatrix} e^t & 0 \\ 0 & e^t \end{bmatrix}$
- (D)  $\begin{bmatrix} 0 & e^t \\ e^t & 0 \end{bmatrix}$

152. A motion control-system has type-2 plant. A recommended cascade compensation scheme for this system employs.

- (A) a lag compensator
- (B) a lead compensator
- (C) either a lag or lead compensator
- (D) neither a lag nor a lead compensator

153. The open-loop transfer function of a unity feedback control system is given

$G(s) = \frac{k}{s(s+1)(s+2)}$  The value of K for stability is,

- (A)  $0 < K < 6$
- (B)  $0 > K > 6$
- (C)  $K > 6$
- (D)  $K > 12$

154. A 12 bit successive approximation ADC outputs binary codes 1111 1111 1111 and 0000 0000 0000 for the analog inputs of +10.0v and -10.0v respectively. Find its resolution

- (A) 4.6 mv
- (B) 2.86 mv
- (C) 2.44 mv
- (D) 4.88 mv

155. In 8085 processor, what are the status of sign and carry flag after the execution of the following program :

MUI B, 91 H

MUI C, A8 H

MOV A, B

ORA C

(A) S = 0, CY = 0

(B) S = 1, CY = 1

(C) S = 1, CY = 0

(D) S = 0, CY = 1

156. In 8051, description of ANL A, direct is

(A) AND register to accumulator

(B) AND byte into indirect address to accumulator

(C) AND immediate data to accumulator

(D) AND byte into direct address to accumulator

157. The pipelined architecture of the 8086 allows the fetch & execute cycles to \_\_\_\_\_ instructions/clock cycle

(A) 1 : 4

(B) 1 : 2

(C) 1 : 1

(D) 2 : 1

158. Determine the contents of register AL in 8086 after the following instructions have executed:

MOV BL, 8 CH

MOV AL, 7 EH

ADD AL, BL

(A) 02H - carry flag set

(B) 0AH - carry flag set

(C) 01H - carry flag not set

(D) 0FH - carry flag set

159. Which of the 8086 instruction can be used to fetch a string of 16-bit word stored in memory, automatically incrementing the memory pointer?

(A) LODW with the direction flag reset

(B) LODSW with the direction flag reset

(C) LODS with the direction flag reset

(D) LOW with the direction flag reset

160. A single instruction to clear the lower four bits of the accumulator in 8085 assembly language is

(A) ANI 0FH

(B) XRI 0FH

(C) ANI FOH

(D) XRI FOH

161. For the faithful reproduction of the message signal, envelope detector should satisfy the following condition.

- (A)  $R_s C \ll \frac{1}{f_c} \ll R_L C \ll \frac{1}{f_m}$       (B)  $R_s C \ll \frac{1}{f_m} \ll R_L C \ll \frac{1}{f_c}$   
 (C)  $R_L C \ll \frac{1}{f_m} \ll R_s C \ll \frac{1}{f_c}$       (D)  $R_L C \ll \frac{1}{f_c} \ll R_L C \ll \frac{1}{f_m}$

162. A signal  $m(t) = 5 \cos 2\pi 100t$  frequency modulates a carrier. The resulting FM signal is  $10 \cos \{(2\pi 10^5 t) + 15 \sin(2\pi 100t)\}$ . The approximate bandwidth of FM would be

- (A) 100 Hz      (B) 1000 Hz  
 (C) 3200 Hz      (D) 100 KHz.

163. Match the following :

- |                 |    |   |
|-----------------|----|---|
| (a) ASK system  | 1. | $P_c = \frac{1}{2} erfc \left[ \sqrt{\frac{0.6E}{N_0}} \right]$ |
| (b) BPSK system | 2. | $P_c = \frac{1}{2} erfc \left[ \sqrt{\frac{E}{4N_0}} \right]$   |
| (c) BFSK system | 3. | $P_c = \frac{1}{2} erfc \left[ \sqrt{\frac{E}{N_0}} \right]$    |

Digital modulation system Vs probabilities of systems

- |   | (a) | (b) | (c) |
|---|-----|-----|-----|
| (A)                                     | 3   | 2   | 1   |
| (B)                                     | 1   | 2   | 3   |
| <input checked="" type="checkbox"/> (C) | 2   | 3   | 1   |
| (D)                                     | 3   | 1   | 2   |

164. Delta modulation and pulse code modulation have a threshold  $P_e$ . (Considering the impact of errors in various digits)

- (A)  $10^{-4}$  and  $10^{-1}$  respectively      (B)  $10^{-4}$  and  $10^{-4}$  respectively  
 (C)  $10^{-1}$  and  $10^{-1}$  respectively       (D)  $10^{-1}$  and  $10^{-4}$  respectively

165. Costas loop is used for carrier synchronization if

- (A) SNR is not too good  
 (B) Carrier component is present in modulated signal spectrum  
 (C) Carrier component is absent in the modulated signal spectrum  
 (D) A split-phase modulation format is used



166. Polar signaling will rule out the use of transformers, since

- (A) it has zero PSD at dc
- (B) it is not bandwidth efficient
- (C) it is more error prone
- (D) it has non zero PSD at dc

167. A receiver for a signal at 100 MHz, uses a 10.7 MHz IF and is low in tracking. What is the local oscillator frequency and image frequency?

- (A) 110.7 MHz and 100 MHz
- (B) 89.3 MHz and 78.6 MHz
- (C) 78.6 MHz and 89.3 MHz
- (D) 100 MHz and 110.7 MHz

168. The probability of error for a DPSK system is, (with referring to noise power spectral density)

- (A)  $\exp\left(-\frac{E_b}{\eta}\right)$
- (B)  $\exp\left[-\sqrt{\frac{E_b}{\eta}}\right]$
- (C)  $\frac{1}{2} \exp\left[-\frac{E_b}{\eta}\right]$
- (D)  $\frac{1}{2} \exp\left[\frac{E_b}{\eta}\right]$

169. For a slow FHSS system, the processing gain is equal to

- (A)  $2^m$
- (B)  $2^{m+1}$
- (C)  $2^m + 1$
- (D)  $2^m - 1$

170. The current relation in an AM wave is given by

- (A)  $I_t = I_c \sqrt{1 + \frac{ma^2}{2}}$
- (B)  $I_t = \sqrt{1 + \frac{ma^2}{2}}$
- (C)  $I_t = I_c \left[1 + \frac{ma^2}{2}\right]$
- (D)  $I_t = I_c \left[1 + \left(\frac{ma}{2}\right)^2\right]$



176. Name the table in which every row has only one stable state
- (A) state table (B) flow table  
 (C) primitive flow table (D) Excitation table

177. How many data inputs are there in a decoder having 64 output lines?
- (A) 1 (B) 64  
 (C) 6 (D) 12

178. For the given circuit, find out the frequency of output Q.

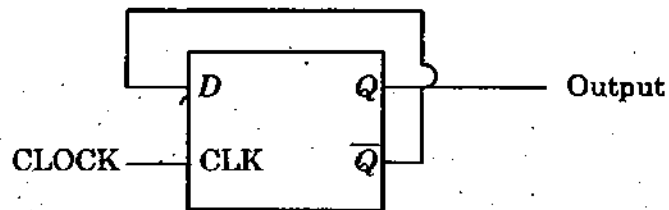

- (A)  $2 \times$  input clock frequency  
 (B)  $\frac{1}{2} \times$  input clock frequency  
 (C) same as input clock frequency  
 (D) Inverse of the propagation delay of flipflop
179. The 10's complement of 3250 is
- (A) 96750 (B) 6750  
 (C) 6749 (D) 96749
180. To make the output Q as \_\_\_\_\_ and \_\_\_\_\_, the preset and clear inputs are used in flip-flops
- (A) 0, 0 (B) 1, 0  
 (C) 0, 1 (D) 1, 1
181. The graph used for the possible merging of states in an asynchronous sequential circuit is
- (A) Merger diagram (B) Flow diagram  
 (C) Timing diagram (D) State diagram
182. What is the other name given for associative memory?
- (A) Cache memory (B) Virtual memory  
 (C) Content Addressable memory (D) Auxiliary memory

183. A Coil consists of 750 turns and current of 10 A in the coil give rise to a magnetic flux of 1.2 m wb. Calculate the inductance of the coil.
- (A)  $L = 0.09 H$  (B)  $L = 1 H$   
 (C)  $L = 0.12 H$  (D)  $L = 10 H$
184. Two inductively coupled coils have self inductance  $L_1 = 50 \text{ mH}$ ,  $L_2 = 200 \text{ mH}$ . Find the value of maximum possible mutual inductance if the coefficient of coupling is 0.5.
- (A) 50 mH  (B) 100 mH  
 (C) 125 mH (D) 150 mH
185. The initial and final value for the following signal are
- $$x(\bar{S}) = \frac{S^2 + 5}{S^2 + 3S + 2}$$
- (A) 1 and 0 (B)  $\infty$  and 1  
 (C) 1 and  $\infty$  (D) 0 and  $\infty$
186. The continuous time unit-step function is defined by
- (A)  $u(t) = \begin{cases} 1, & t > 0 \\ 0, & t < 0 \end{cases}$  (B)  $u(t) = \begin{cases} 1, & t \geq 0 \\ 0, & t < 0 \end{cases}$   
 (C)  $u(t) = \begin{cases} 1, & t > 0 \\ 0, & t \leq 0 \end{cases}$  (D)  $u(t) = 1, t \neq 0$
187. Z-transform of the signal  $X[n] = \begin{Bmatrix} 1, 2, 4, 2 \\ \downarrow \end{Bmatrix}$  is
- (A)  $X(Z) = z^2 + 2z + 4 + 2z^{-1}$  ROC : Entire Z- plane  
 (B)  $X(Z) = z^2 + 2z + 4 + 2z^{-1}$  ROC :  $\frac{\text{except } z = 0 \text{ and } z = \infty}{\text{Entire } z - \text{ plane}}$   
 (C)  $X(Z) = 1 + 2z^{-1} + 4z^{-2} + 2z^{-3}$  ROC: Entire z-plane  
 (D)  $X(Z) = 1 + 2z^{-1} + 4z^{-2} + 2z^{-3}$  ROC: Entire z-plane except  $z = 0$
188. Given an analog signal  $x(t) = 5 \cos 200\pi t$ . The minimum sampling rate required to avoid aliasing is
- (A) 100 Hz  (B) 200 Hz  
 (C) 400 Hz (D) 50 Hz



196. Consider reconstructing a sinewave of frequency  $f_m$ , the sampling frequency needed is,
- (A)  $f_m$  (B)  $2 f_m$   
 (C) slightly greater than  $2 f_m$  (D) slightly greater than  $f_m/2$

197. The value of  $R_1$  and  $R_2$  in the given circuit are (in ohms)

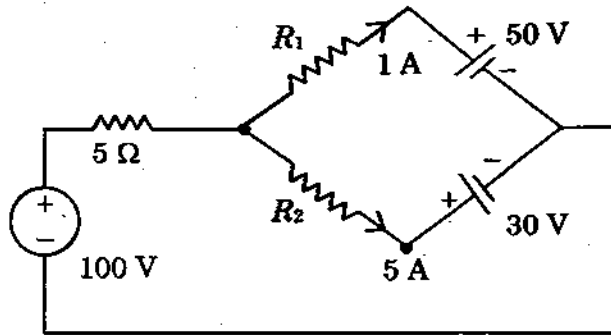

- (A)  $R_1 = 20$   $R_2 = 2$  (B)  $R_1 = 10$   $R_2 = 12$   
 (C)  $R_1 = 2$   $R_2 = 20$  (D)  $R_1 = 12$   $R_2 = 10$

198. Laplace's equation is

- (A)  $\nabla^2 V = \frac{-\rho}{\epsilon}$  (B)  $\nabla \cdot \vec{V} = 0$   
 (C)  $\nabla \cdot \vec{V} = \rho$   (D)  $\nabla^2 V = 0$

199. The \_\_\_\_\_ parameters are usually used in connection with partially polarized radiation

- (A) Poincare sphere (B) ellipticity  
 (C) spherical  (D) stokes

200. Assuming an aperture efficiency of 70 percent, what is the directivity of a parabolic dish antenna as a function of its radius?

- (A)  $D = 28 \left( \frac{r}{\lambda} \right)^2$  (B)  $D = 8.8 \left( \frac{r}{\lambda} \right)^2$   
 (C)  $D = 0.7 \left( \frac{r}{\lambda} \right)^2$  (D)  $D = 2.8 \left( \frac{r}{\lambda} \right)^2$

**SPACE FOR ROUGH WORK**

**SPACE FOR ROUGH WORK**



SPACE FOR ROUGH WORK

SEAL